



**BMW  
MOTORRAD**



Installation instructions

# **BMW MOTORRAD COMMUNICATION SYSTEM CONNECTEDRIDE COM U1**

**MAKE LIFE A RIDE**

---

---

**BEFORE COMMENCING WORK, YOU MUST READ THESE INSTALLATION INSTRUCTIONS THROUGH CAREFULLY AND MAKE SURE YOU UNDERSTAND THEM FULLY.**

We congratulate you on your choice of optional accessories from BMW Motorrad that will enable you to customise your motorcycle in accordance with your personal preferences.

Safety is invariably an essential prerequisite for extracting full benefit and enjoyment from new accessories. Some work calls for special tools and possibly a thorough knowledge of motorcycle technology. If you are in doubt consult a specialist workshop, preferably your authorised BMW Motorrad dealer.

Since we provide you with a multitude of accessories and optional equipment, we cannot cover all equipment specifications in these installation instructions. Therefore we restrict ourselves to the basic version of the corresponding model. The removal and installation of other possibly installed accessories is described in the corresponding installation instructions. Consult your authorised BMW Motorrad dealer if you no longer have access to the sets of instructions you need.

If you have questions concerning your motorcycle or any of the accessories from our range, your authorised BMW Motorrad dealer will gladly provide advice and assistance.

We at BMW Motorrad hope you will enjoy riding your BMW and that all your journeys will be pleasant and safe.

---

**THE SYMBOLS USED TO DRAW ATTENTION TO PRECAUTIONARY STATEMENTS IN THIS MANUAL ARE AS FOLLOWS:**
 **CAUTION**

Low-risk hazard. Non-avoidance can lead to slight or moderate injury.

 **DANGER**

High-risk hazard. Non-avoidance leads to fatal or severe injury.

 **NOTICE**

Specific instructions on how to operate, control, adjust or look after items of equipment on the motorcycle.

- ▶ Start of the main activity
- ▷ Start of the secondary activity
- Instruction

 **WARNING**

Medium-risk hazard. Non-avoidance can lead to fatal or severe injury.

 **ATTENTION**

Special notes and precautionary measures. Non-compliance can lead to damage to the vehicle or accessory and, consequently, to voiding of the warranty.

 **Tightening torque**

Screws, bolts and nuts are tightened in accordance with the applicable DIN/ISO standards. Tightening torques that deviate from the standards are stated. Non-compliance can result in damage to the vehicle or accessories or can endanger the driver.

- ◀ End of the main activity
- ◁ End of the secondary activity
- ◇ End of validity designation CS (construction status), OE (optional extra) or OA (optional accessory)

All rights reserved.

## BMW Motorrad communication system ConnectedRide Com U1

### Requisite tools

- Ring stand for helmet assembly

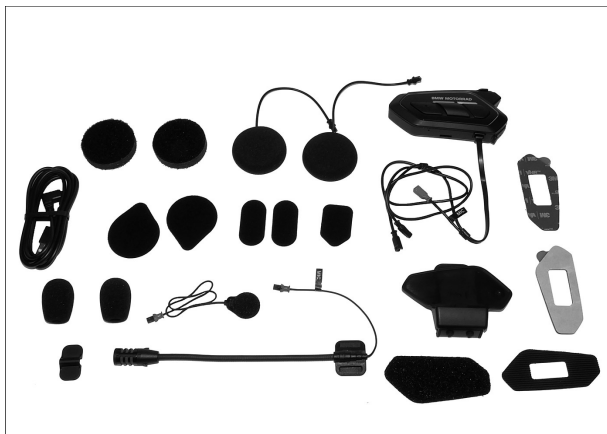

### Delivery specification

- 76 51 5A50A99 Connected-Ride Com U1 communication system installation kit consisting of:
  - Operating panel
  - Loudspeaker 2
  - Microphone with cable
  - Boom microphone
  - Loudspeaker pad 2
  - Microphone attachment 2
  - Holder for boom microphone
  - Charging and data cables
  - Hook and loop fastener to mount the boom microphone
  - Hook and loop fastener to mount the loudspeaker replacement 2
  - Hook and loop fastener to mount the cable microphone and the holder of the boom microphone 2
  - Hook and loop fasteners to mount the operating facility
  - Double-sided adhesive pad to mount the operating facility 2
  - Mounting clip for operating unit
  - Brief instructions

### General instructions

#### NOTICE

Once the retrofit kit has been installed by the workshop, these installation instructions must be handed over to the customer.

Make sure that these installation instructions accompany the retrofit kit when it is passed on to a third party.

## 76 51 012 Installing ConnectedRide Com U1 wireless communication system

### ATTENTION

#### Hard worktop

Damage to the surface of the helmet

- Use the assembly ring or a clean, soft pad.

### NOTICE

The installation is explained on the example of the BMW Motorrad helmet Street X.

The installation in other helmets is similar.

### NOTICE

Before start-up, check the communication system for the current software version and update, if required.

# 1

### ► Removing cheek pad

- Open the visor.
- Loosen cheek pads right **(1)** and left **(2)** on hook and loop fasteners **(arrows)**.



- Loosen push-buttons **(1)** behind left cheek pad **(2)**.
- Pull out plug-in strip **(4)**.
- Remove cheek pad **(2)** and work chinstrap **(3)** clear.

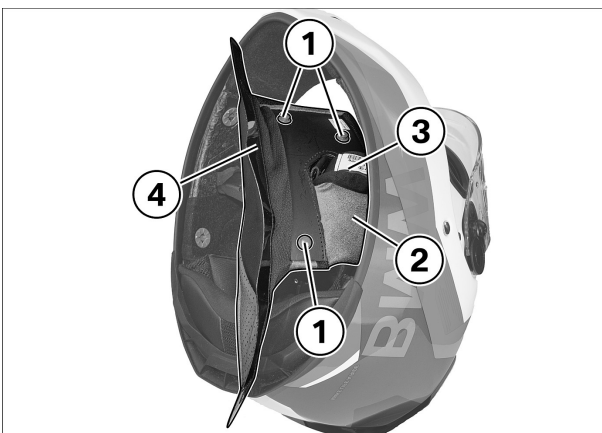

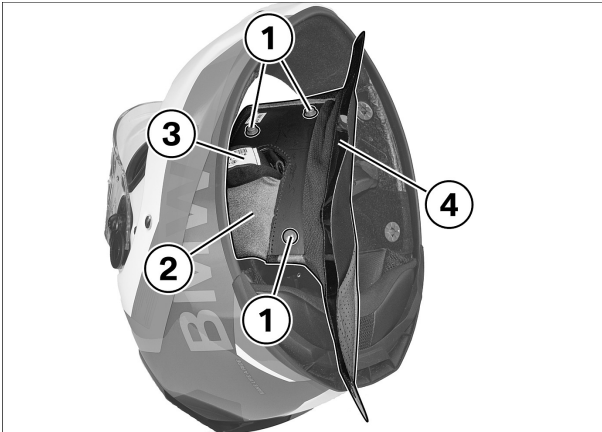

- Loosen push-buttons **(1)** behind right cheek pad **(2)**.
- Pull out plug-in strip **(4)**.
- Remove cheek pad **(2)** and work chinstrap **(3)** clear.



**2**

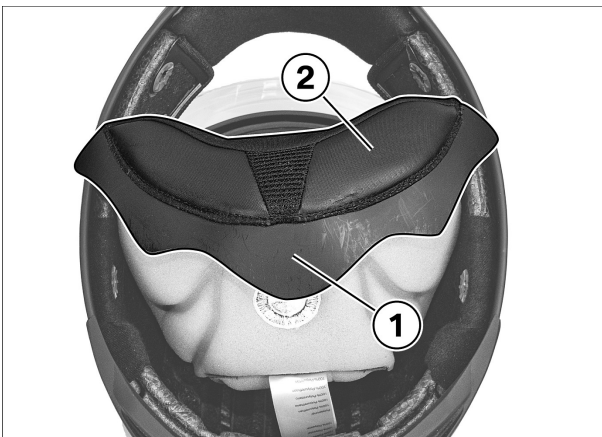

► **Loosening the head pads**

- Pull out plug-in strip **(1)** and push head pad **(2)** to front.



**3**

► **Installing the operating unit**

- To clean the helmet, be sure to follow the care instructions in the operating instructions for the helmet.

**NOTICE**

Faces that will be in contact with the adhesive must be dry, clean and free from dust and grease.

- Clean bonding surfaces on terminal and operating unit.

**NOTICE**

For better operation, it is recommended to install the operating unit on the left side of the helmet.

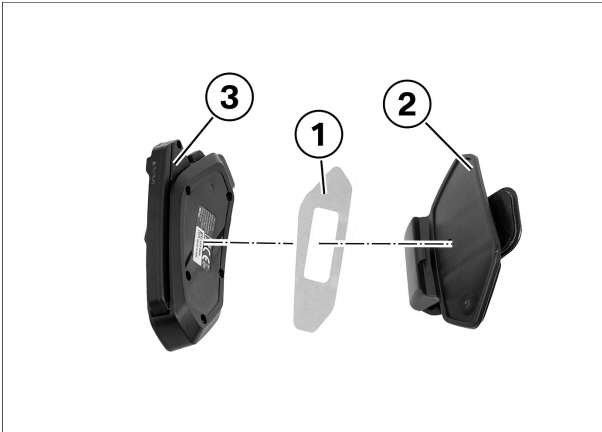

- Attach adhesive pad **(1)** on mounting clip **(2)** and install operating unit **(3)**.

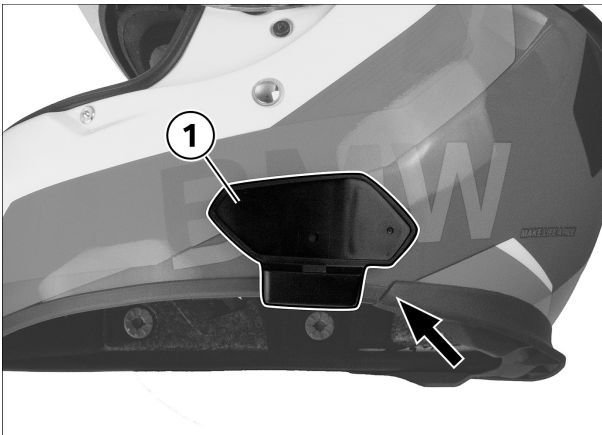

- Attach mounting clip **(1)** on helmet and align on rubber coating **(arrow)**.
- » Make sure surface is clean and carefully slide mounting clip over edge of helmet.

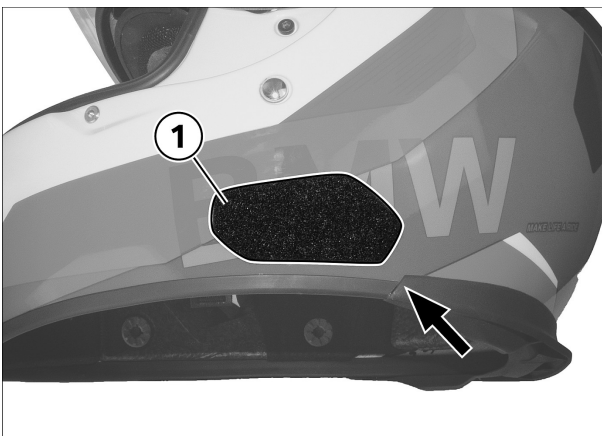

▷ **Version 2 (hook and loop pad)**

- With this version, the hook and loop pad is secured directly on the helmet.
- Attach hook and loop pad **(1)** near rubber coating **(arrow)**.
- » Attach counterpart of hook and loop pad on operating unit.

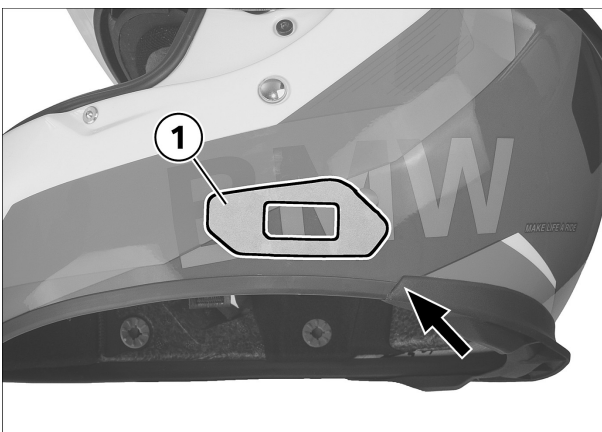

▷ **Version 3 (adhesive pad)**

- With this version, the adhesive pad is secured directly on the helmet.
- Attach adhesive pad **(1)** near rubber coating **(arrow)**.

**NOTICE**

Removal of the adhesive pad may damage the helmet paint.



4

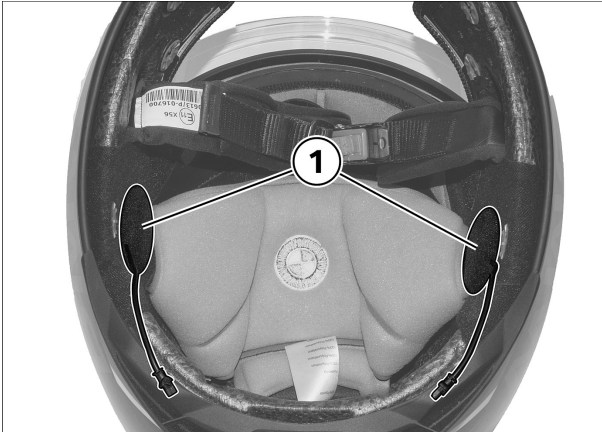

#### ► Installing speaker

- Secure speaker 1 and work cable down.
- » To adjust the wear comfort individually, optional speaker pads can be installed under the speakers.
- Adjust speaker position individually to ear height.

#### NOTICE

For an optimal sound result, install speakers at ear height.



5

#### ► Installing microphone

- An optional microphone with cable or a boom microphone can be installed.

#### NOTICE

The boom microphone is recommended for flip-up helmets or jet helmets.

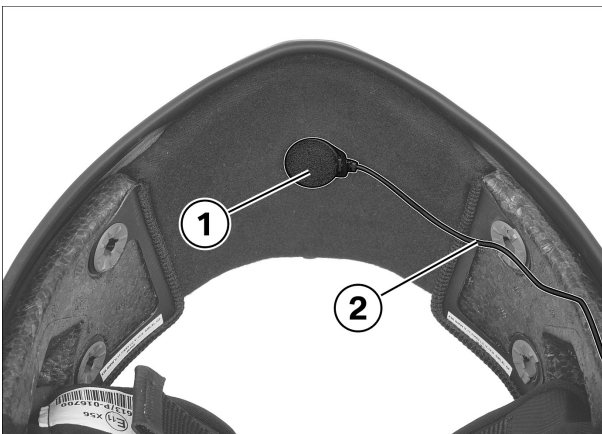

- Secure microphone with cable **(1)** with hook and loop fastener on chin piece.
- Work cable **(2)** down.



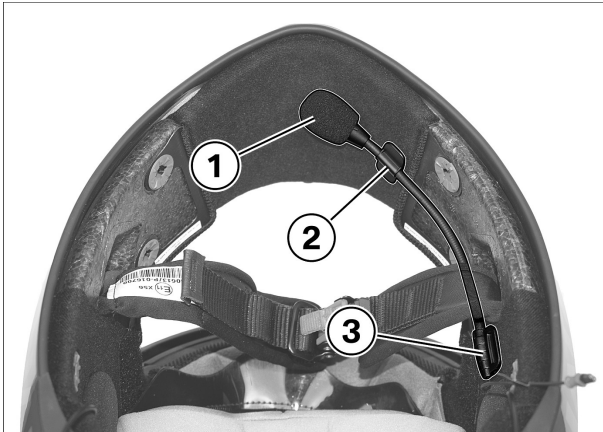

▷ **Version 2 (boom microphone)**

- Secure boom microphone (1) with hook and loop fastener (2) and (3) in suitable position on left in helmet.
- » If necessary, bond hook and loop pad for securing holders.



**6**

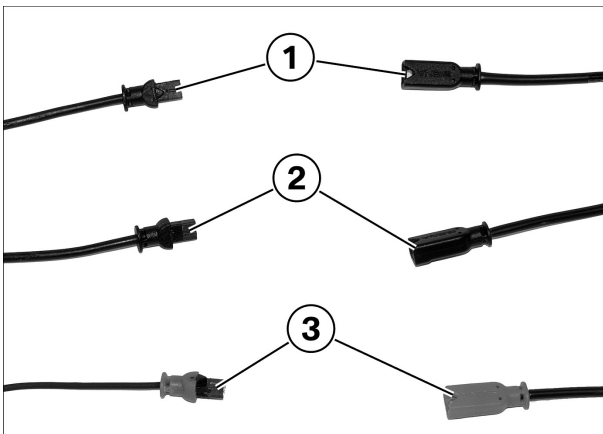

▶ **Connecting and routing cables**

- Connect plug connections for speaker (1), (2) and microphone (3).

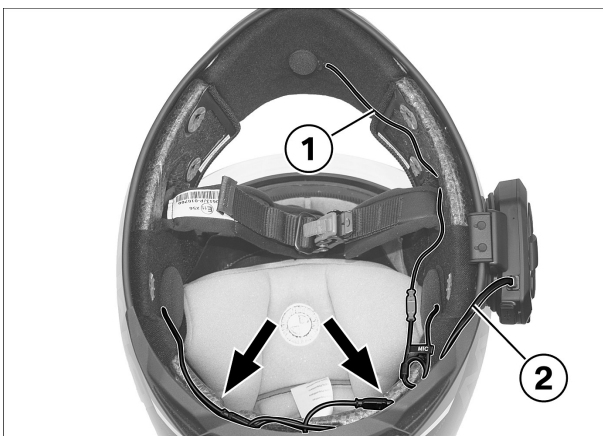

- Route cable for microphone (1) to rear.
- Route cable for operating unit (2) tightly around helmet edge and route to the rear area of the helmet.
- Form excess cable lengths into loops and stow in the neck area (**arrows**), thereby utilizing existing recesses.
- Make sure that cables are not kinked or crushed.



7



► **Cutting cheek pad plug-in strip**

- Cut plug-in strip **(1)** of left cheek pad to size in rear area **(arrow)**.
- » Exact position of aperture must align with position of operating unit cable

8

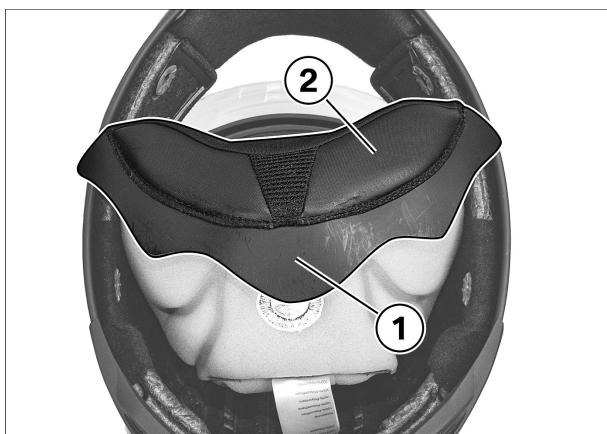

► **Securing head pad**

- Position head pad **(2)** and insert plug-in strip **(1)** making sure all cables are stowed behind head pad **(2)**.

9

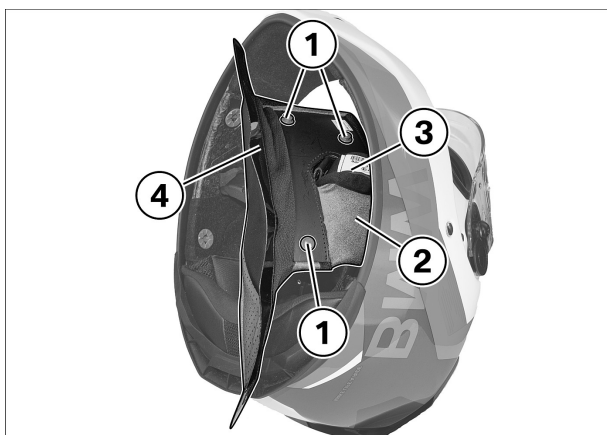

► **Installing cheek pad**

- Work chinstrap **(3)** into left cheek pad **(2)**.
- Insert plug-in strip **(4)** and work cable for operating unit through aperture.
- Secure push-buttons **(1)**.

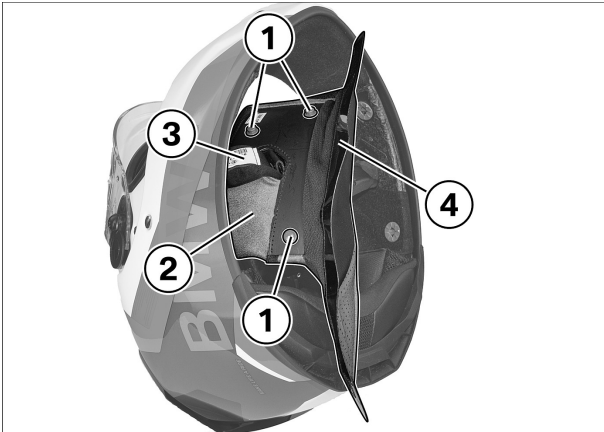

- Work chinstrap **(3)** into right cheek pad **(2)**.
- Insert plug-in strip **(4)**.
- Secure push-buttons **(1)**.



- Check correct fit of both cheek pads **(1)** and **(2)** correct, if necessary.
- Secure cheek pads right **(1)** and left **(2)** on hook and loop fasteners **(arrows)**.

## 10

### ► **Functional check of BMW Motorrad communication system**

- Check Bluetooth functionality by connecting the helmet with a second helmet or a mobile phone and proceed according to BMW Motorrad communication system operating instructions.
- Connect battery charger and fully charge operating unit.