



**BMW
MOTORRAD**

RIDER'S MANUAL

R 1250 GS



MAKE LIFE A RIDE

Vehicle data

Model

Vehicle Identification Number

Colour code

Date of first registration

Registration number

Dealership details

Person to contact in Service department

Ms/Mr

Phone number

Dealership address/phone number (company stamp)

YOUR BMW.

We congratulate you on your choice of a vehicle from BMW Motorrad and welcome you to the community of BMW riders. Familiarise yourself with your new vehicle so that you can ride it safely and confidently in all traffic situations.

About this rider's manual

Read this rider's manual carefully before starting to use your new BMW. It contains important information on how to operate the controls and how to make the best possible use of all your BMW's technical features.

In addition, it contains information on maintenance and care to help you maintain your vehicle's reliability and safety, as well as its value.

If the time comes to sell your BMW, please remember to hand over this rider's manual to the new owner. It is an important part of the vehicle.

We hope you will enjoy riding your BMW and that all your journeys will be pleasant and safe

BMW Motorrad.

01 GENERAL INSTRUCTIONS	2	03 STATUS INDICATORS	26
Overview	4	Indicator and warning lights	28
Abbreviations and symbols	4	TFT display in Pure Ride view	29
Equipment	5	TFT display in Menu view	30
Technical data	5	Warning indicators	31
Currency	6		
Additional sources of information	6	04 OPERATION	58
Certificates and operating licences	6	Ignition switch/steering lock	60
Data memory	6	Ignition with Keyless Ride	62
Intelligent emergency call system	11	Emergency-off switch (kill switch)	66
		Intelligent emergency call	66
02 GENERAL VIEWS	16	Lights	69
General view, left side	18	Daytime riding light	70
General view, right side	19	Hazard warning lights	72
Underneath the seat	20	Turn indicators	72
Multifunction switch, left	21	Traction control (DTC)	73
Multifunction switch, right	22	Electronic Suspension Adjustment (D-ESA)	74
Multifunction switch, right	23	Riding mode	77
Instrument cluster	24	PRO riding mode	80
		Adaptive cruise control	81
		Hill Start Control	84
		Anti-theft alarm (DWA)	87
		Tyre pressure control (RDC)	90
		Heating	90

05 TFT DISPLAY	92	Starting	136
General instructions	94	Running in	138
Principle	95	Off-road use	140
Pure Ride view	101	Shifting gear	141
General settings	102	Brakes	142
Bluetooth	104	Parking your motorcycle	144
My vehicle	107	Refuelling	145
Navigation	110	Securing motorcycle for transportation	150
Media	112		
Phone	112		
Display software version	113		
Display licence information	113		
		<hr/>	
06 SETTING	114	08 ENGINEERING DETAILS	152
Mirrors	116	General notes	154
Headlight	117	Antilock Brake System (ABS)	154
Windscreen	118	Traction control (DTC)	158
Clutch	118	Dynamic engine brake control (MSR)	160
Gearshift lever	119	Dynamic ESA	160
Brakes	119	Riding mode	161
Footrests	121	Dynamic Brake Control	165
Handlebars	122	Tyre pressure control (RDC)	166
Seats	122	Gear Shift Assistant	168
Spring preload	125	Hill Start Control	169
Damping	127	ShiftCam	170
		Adaptive cornering light	171
<hr/>			
07 RIDING	130		
Safety instructions	132		
Comply with checklist	135		
Always before riding off	135		
At every third refuelling stop	136		

09 MAINTENANCE 174

General notes	176
Toolkit	177
Service tool kit	177
Front-wheel stand	178
Engine oil	179
Brake system	181
Clutch	185
Coolant	185
Tyres	187
Rims and tyres	188
Wheels	189
Air filter	195
Lighting	197
Jump-starting	197
Battery	199
Fuses	203
Diagnostic connector	205

10 ACCESSORIES 208

General instructions	210
Power sockets	210
USB charging socket	211
Cases	212
Topcase	215
Navigation system	220

11 CARE 226

Care products	228
Washing the vehicle	228
Cleaning easily damaged components	229
Care of paintwork	230
Paintwork preservation	231

Laying up the motorcycle	231
Restoring motorcycle to use	231

12 TECHNICAL DATA 232

Troubleshooting chart	234
Screw connections	236
Fuel	238
Engine oil	239
Engine	239
Clutch	240
Transmission	240
Rear-wheel drive	241
Frame	241
Chassis and suspension	242
Brakes	243
Wheels and tyres	244
Electrical system	245
Anti-theft alarm	246
Dimensions	246
Weights	249
Riding specifications	249

13 SERVICE 250

Reporting safety-relevant defects	252
BMW Motorrad Service	253
BMW Motorrad Service history	253
BMW Motorrad Mobility services	254
Maintenance work	254

BMW Service	254
Maintenance schedule	256
Maintenance confirmations	257
Service confirmations	271

APPENDIX **274**

Declaration of conformity for electronic immobiliser	275
Certificate for electronic immobiliser	281
Declaration of conformity for Keyless Ride	283
Certificate for Keyless Ride	288
Declaration of conformity for tyre pressure control (RDC)	292
Certificate for tyre pressure control (RDC)	298
Declaration of conformity for intelligent emergency call	299
Declaration of conformity for anti-theft alarm system	305
Declaration of conformity for TFT instrument cluster	310
Certificate for TFT instrument cluster	316

GENERAL IN- STRUCTIONS

01

OVERVIEW	4
ABBREVIATIONS AND SYMBOLS	4
EQUIPMENT	5
TECHNICAL DATA	5
CURRENCY	6
ADDITIONAL SOURCES OF INFORMATION	6
CERTIFICATES AND OPERATING LICENCES	6
DATA MEMORY	6
INTELLIGENT EMERGENCY CALL SYSTEM	11

4 GENERAL INSTRUCTIONS

OVERVIEW

An important aspect of this Rider's Manual is that it can be used for quick and easy reference. Consulting the extensive index at the end of this Rider's Manual is the fastest way to find information on a particular topic or item. To first read an overview of your motorcycle, please go to Chapter 2. All maintenance and repair work on the motorcycle is documented in Chapter 12. This record of the maintenance work you have had performed on your vehicle is a precondition for generous treatment of goodwill claims. When the time comes to sell your BMW, please remember to hand over this Rider's Manual; it is an important part of the motorcycle.

ABBREVIATIONS AND SYMBOLS



 **CAUTION** Low-risk hazard. Non-avoidance can lead to slight or moderate injury.

 **WARNING** Medium-risk hazard. Non-avoidance can lead to fatal or severe injury.

 **DANGER** High-risk hazard. Non-avoidance leads to fatal or severe injury.

 **ATTENTION** Special notes and precautionary measures. Non-compliance can lead to damage to the vehicle or accessory and, consequently, to voiding of the warranty.

 **NOTICE** Specific instructions on how to operate, control, adjust or look after items of equipment on the vehicle.

- Instruction.
- » Result of an activity.
- ▣ Reference to a page with more detailed information.
- ◁ Indicates the end of a passage relating to specific accessories or items of equipment.
-  Tightening torque.
-  Technical data.
- NV National-market version.

OE	Optional equipment. The vehicles are assembled complete with all the BMW Motorrad optional equipment originally ordered.
OA	Optional accessories. You can obtain BMW Motorrad optional accessories through your authorised BMW Motorrad dealer; optional accessories have to be retrofitted to the vehicle.
ABS	Anti-lock brake system.
D-ESA	Electronic chassis and suspension adjustment.
DTC	Dynamic Traction Control
DWA	Anti-theft alarm.
EWS	Electronic immobiliser.
MSR	Dynamic engine brake control.
RDC	Tyre pressure monitoring.

EQUIPMENT

When you ordered your BMW Motorrad, you chose various items of custom equipment. These operating instructions describe the optional equipment (OE) offered by BMW and selected optional accessories (OA). This explains why the manual may also contain descriptions of equipment that you might not have selected. Please note, too, that on account of country-specific differences, your motorcycle might not be exactly as illustrated. If your motorcycle contains equipment that has not been described, its description can be found in a separate manual.

TECHNICAL DATA

All dimensions, weights and power ratings stated in the operating instructions are quoted to the standards and comply with the tolerance requirements of the Deutsches Institut für Normung e.V. (DIN). Technical data and specifications in this rider's manual serve as reference points. The vehicle-specific data may deviate from these, for example as a result of selected optional

6 GENERAL INSTRUCTIONS

equipment, the national-market version or country-specific measuring procedures. Detailed values can be taken from the vehicle registration documents, or can be obtained from your authorised BMW Motorrad retailer or another qualified service partner or specialist workshop. The specifications in the vehicle documents always have priority over the information provided in this rider's manual.

CURRENCY

The high safety and quality standards of BMW motorcycles are maintained by constant development work on designs, equipment and accessories. Because of this, your motorcycle may differ from the information supplied in the Rider's Manual. Nor can BMW Motorrad entirely rule out errors and omissions. We hope you will appreciate that no claims can be entertained on the basis of the data, illustrations or descriptions in these operating instructions.

ADDITIONAL SOURCES OF INFORMATION

Authorised BMW Motorrad retailer

Your authorised BMW Motorrad retailer will be happy to answer any questions you may have.

Internet

The operating instructions for your vehicle, operating and installation instructions for accessories and general information about BMW Motorrad, in relation to technology, for example, are available for download from **www.bmw-motorrad.com/manuals**.

CERTIFICATES AND OPERATING LICENCES

The certificates for the vehicle and the official operating licences for accessories can be downloaded from **bmw-motorrad.com/certification**.

DATA MEMORY

General

Control units are installed in the vehicle. Control units process data that they receive, for example, from vehicle sensors, or that they generate them-

selves or exchange between each other. Some control units are required for the vehicle to function safely or provide assistance during riding, for example assistance systems. In addition, control units enable comfort or infotainment functions.

Information on data that has been stored or exchanged can be obtained from the manufacturer of the vehicle, for example via a separate booklet.

Personal reference

Each vehicle is identified with a clear vehicle identification number. Depending on the country, the vehicle identification number, the number plate and the corresponding authorities can be referenced to ascertain the vehicle owner. There are also other ways to use data obtained from the vehicle to trace the rider or vehicle owner, for example using the Connected-Drive user account.

Data protection rights

In accordance with applicable data protection laws, vehicle users have certain rights in relation to the manufacturer of the vehicle or in relation to

companies which collect or process personal data.

Vehicle users have the right to obtain full information at no cost from persons or entities storing personal data of the vehicle user.

These entities may include:

- Manufacturer of the vehicle
- Qualified service partners
- Specialist workshops
- Service providers

Vehicle users have the right to request information on what personal data has been stored, for what purpose the data is used, and where the data comes from. To obtain this information, proof of ownership or use is required.

The right to information also includes information about data that has been shared with other companies or entities. The website of the vehicle manufacturer contains the applicable data protection information. This data protection information includes information on the right to have data deleted or corrected. The manufacturer of the vehicle also provides their contact details and those of the data protection officer on their website.

8 GENERAL INSTRUCTIONS

The vehicle owner can also request that a BMW Motorrad retailer or another qualified service partner or specialist workshop read out the data that is stored in the vehicle for a charge.

The vehicle data is read out using the legally prescribed socket for on-board diagnosis (OBD) in the vehicle.

Legal requirements for the disclosure of data

As part of its legal responsibilities, the manufacturer of the vehicle is obligated to make its stored data available to the relevant authorities. This data is provided in the required scope in individual cases, for example to clarify a criminal offence. In the context of applicable laws, public agencies are entitled in individual cases to read out data from the vehicle themselves.

Operating data in the vehicle

Control units process data to operate the vehicle.

This includes, for example:

- Status reports of the vehicle and its individual components, for example wheel revolutions, wheel speed, deceleration

- Environmental conditions, for example temperature

The data is only processed in the vehicle itself and is generally non-permanent. The data is not stored beyond the operating period.

Electronic components, for example control units, contain components for storing technical information. Information can be temporarily or permanently stored on the vehicle condition, component loads, incidents or errors.

This information is generally used to document the condition of a component, a module, a system or the surrounding area, for example:

- Operating conditions of system components, for example filling levels, tyre pressure
- Malfunctions and faults in important system components, for example light and brakes
- Response of the vehicle in special riding situations, for example engagement of the driving dynamics systems
- Information on incidents resulting in damage to the vehicle

The data is necessary for the provision of control unit functions. Furthermore, the data

is used to detect and rectify malfunctions and to enable the vehicle manufacturer to optimise vehicle functions.

The vast majority of this data is non-permanent and is only processed in the vehicle itself. Only a small amount of the data is stored in incident or fault memories as required by events.

If services are accessed, for example repairs, service processes, warranty cases and quality assurance measures, this technical information can be read out of the vehicle together with the vehicle identification number.

The information can be read out by a BMW Motorrad retailer or another qualified service partner or specialist workshop. The legally stipulated socket for on-board diagnosis (OBD) in the vehicle is used to read out the data. The data is obtained, processed and used by the relevant parts of the retailer network. The data is used to document the technical conditions of the vehicle, to help with error localization, to comply with warranty

obligations and to improve quality.

In addition, the manufacturer has various product monitoring obligations arising from product liability legislation. To meet these obligations, the vehicle manufacturer requires technical data from the vehicle. The data from the vehicle can also be used to check warranty claims from the customer. Error and incident memories in the vehicle can be reset during servicing or repair work by a BMW Motorrad retailer or another qualified service partner or specialist workshop.

Data input and data transfer in the vehicle

General

Depending on the equipment, comfort and customised settings can be stored in the vehicle and can be changed or reset at any time.

This includes, for example:

- Settings of the windscreen position
- Chassis and suspension settings

If required, data can be entered in the entertainment and communication system of the vehicle, for example using a smartphone.

10 GENERAL INSTRUCTIONS

Depending on the individual equipment, this includes:

- Multimedia data, such as music for playback
- Contacts data for use in connection with a communication system or an integrated navigation system
- Entered destinations
- Data on the use of internet services. This data can be stored locally in the vehicle or is located on a device that is connected to the vehicle, for example smartphone, USB stick, MP3 player. If this data is stored in the vehicle, the data can be deleted at any time.

This data is transferred to third parties only if personally requested within the context of using online services. This depends on the selected settings when using the services.

Incorporation of mobile devices

Depending on the equipment, mobile devices connected to the vehicle, for example smartphones, can be controlled using the operating elements of the vehicle.

The image and sound of the mobile device can then be output via the multimedia system.

At the same time, specific information is transferred to the mobile device. Depending on the type of integration, this includes, for example, position data and additional general vehicle information. This enables optimal use of the selected apps, for example navigation or music playback. The type of additional data processing is determined by the provider of the respective app. The scope of the possible settings depends on the corresponding app and the operating system of the mobile device.

Services

General

If the vehicle has a wireless connection, this enables the exchange of data between the vehicle and other systems. The wireless connection is enabled by the vehicle's own transmitter and receiver unit or using personally integrated mobile devices, for example smartphones. Online functions can be used using this wireless connection. These include online services and apps that are provided by the vehicle manufacturer or by other providers.

Services of the vehicle manufacturer

For online services of the vehicle manufacturer, the individual functions are described at suitable points, for example rider's manual, website of the manufacturer. At the same time, information is also provided on the relevant data protection law. Personal data may be used to provide online services. Data is exchanged using a secure connection, for example with the IT systems provided by the vehicle manufacturer. Obtaining, processing and using personal data outside of the normal provision of services requires legal permission, contractual agreement or consent. It is also possible to have the entire data connection activated or deactivated. Statutory functions are excluded from this.

Services from other providers

When using online services from other providers, these services are subject to the responsibility and the data protection and operating conditions of the individual provider. The vehicle manufacturer has no influence on the content that is exchanged in this instance. Information on the

type, scope and purpose of the data capture and use of personal data as part of the services of third parties can be ascertained from the individual provider.

INTELLIGENT EMERGENCY CALL SYSTEM

–with intelligent emergency call^{OE}

Principle

The intelligent emergency call system enables manual or automatic emergency calls, for example in the event of an accident.

The emergency calls are received by an emergency call centre that is commissioned by the vehicle manufacturer. For information on operating the intelligent emergency call system and its functions, please refer to "Intelligent emergency call".

Legal basis

Processing of personal data using the intelligent emergency call system is in line with the following regulations:

12 GENERAL INSTRUCTIONS

–Protection of personal data:
Directive 95/46/EC of the European Parliament and of the Council.

–Protection of personal data:
Directive 2002/58/EC of the European Parliament and of the Council.

The legal basis for the activation and function of the intelligent emergency call system is the concluded ConnectedRide contract for this function, as well as the corresponding laws, ordinances and directives of the European Parliament and of the European Council.

The relevant ordinances and directives regulate the protection of natural persons during the processing of personal data.

The processing of personal data by the intelligent emergency call system satisfies the European directives for the protection of personal data. The intelligent emergency call system processes personal data only with the agreement of the vehicle owner.

The intelligent emergency call system and other services with additional benefits can process personal data only with the express permission of the per-

son affected by the data processing, for example the vehicle owner.

SIM card

The intelligent emergency call system operates via the mobile phone network using the SIM card installed in the vehicle.

The SIM card is permanently logged into the mobile phone network to enable rapid connection setup. Data is sent to the vehicle manufacturer in the event of an emergency.

Improving quality

The data that is transferred in an emergency is also used by the manufacturer of the vehicle to improve product and service quality.

Location determination

The position of the vehicle can be determined exclusively by the mobile phone network provider based on the mobile phone site locations. It is not possible for the provider to trace a connection between the vehicle's VIN and the phone number of the installed SIM card. Only the manufacturer of the vehicle can link a VIN and the phone number of the SIM

card installed in a particular vehicle.

Log data of emergency calls

The log data of emergency calls is stored in a memory of the vehicle. The oldest log data is regularly deleted. The log data includes, for example, information on when and where an emergency call was made. In exceptional cases, the log data can be read out of the vehicle memory. As a rule, log data is only read out following a court order, and this is only possible if the corresponding devices are connected directly to the vehicle.

Automatic emergency call

The system is designed so that, following a sufficiently serious accident, which is detected by sensors in the vehicle, an emergency call is automatically activated.

Sent information

When making an emergency call using the intelligent emergency call system, the system forwards the same information to the designated emergency call centre as is forwarded to the public emergency operations centre by the statutory emergency call system eCall.

In addition, the intelligent emergency call system sends the following additional information to an emergency call centre commissioned by the vehicle manufacturer and, if required, to the emergency services:

- Accident data, for example the direction of impact detected by the vehicle sensors, to assist the emergency services response.
- Contact details, for example the phone number of the installed SIM card and the phone number of the rider, if available, to enable rapid contact with those involved in the accident if required.

Data storage

The data for an activated emergency call is stored in the vehicle. The data contains information on the emergency call, for example the location and time of the emergency call. The voice recordings of the emergency call are stored at the emergency call centre. The voice recordings of the customer are stored for 24 hours in case details of the emergency call need to be analysed. After this, the voice recordings are deleted. The voice

14 GENERAL INSTRUCTIONS

recordings of the employee of the emergency call centre are stored for 24 hours for quality assurance purposes.

Information on personal data

The data that is processed as part of the intelligent emergency call is processed exclusively to carry out the emergency call. As part of its statutory obligation, the manufacturer of the vehicle provides information about the data that it has processed and any data that it still has stored.

GENERAL VIEWS

02

GENERAL VIEW, LEFT SIDE	18
GENERAL VIEW, RIGHT SIDE	19
UNDERNEATH THE SEAT	20
MULTIFUNCTION SWITCH, LEFT	21
MULTIFUNCTION SWITCH, RIGHT	22
MULTIFUNCTION SWITCH, RIGHT	23
INSTRUMENT CLUSTER	24

18 GENERAL VIEWS

GENERAL VIEW, LEFT SIDE

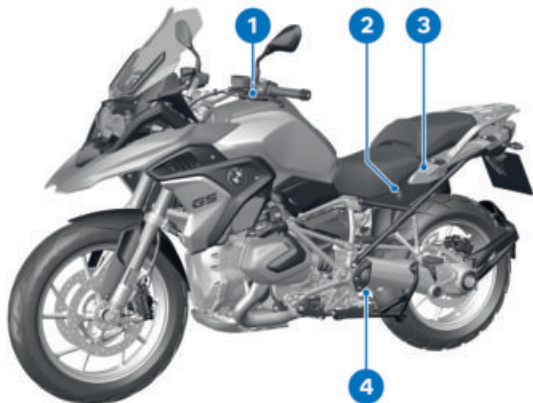

- 1 Fuel filler neck (▶▶▶ 146)
- 2 12V socket
- 3 Seat lock (▶▶▶ 122)
- 4 Setting the rear damping
(down at the spring strut)
(▶▶▶ 127)

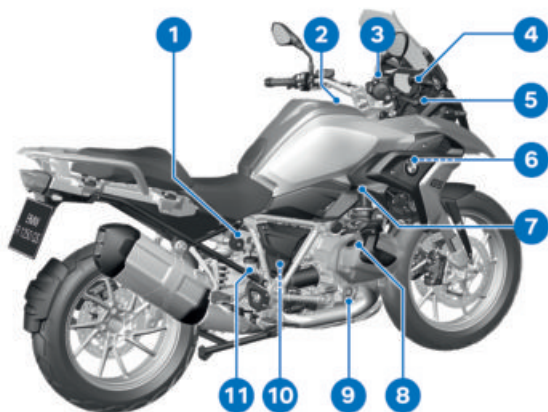
GENERAL VIEW, RIGHT SIDE

- | | |
|--|---|
| <p>1 Adjuster for spring pre-load, rear (►► 126)</p> <p>2 Air filter (under the centre trim panel) (►► 195)</p> <p>3 Brake-fluid reservoir, front (►► 183)</p> <p>4 Height adjustment of the windscreen (►► 118)</p> <p>5 USB charging socket (►► 211)</p> <p>6 Vehicle identification number (on the steering-head bearing)
Type plate (on the steering-head bearing)</p> | <p>7 Coolant-level indicator (►► 185)
Coolant reservoir (►► 186)</p> <p>8 Oil filler opening (►► 180)</p> <p>9 Engine oil level indicator (►► 179)</p> <p>10 Behind the side trim panel: Battery (►► 199)
Remote positive terminal (►► 197)
Diagnostic connector (►► 205)</p> <p>11 Brake-fluid reservoir, rear (►► 184)</p> |
|--|---|

20 GENERAL VIEWS

UNDERNEATH THE SEAT

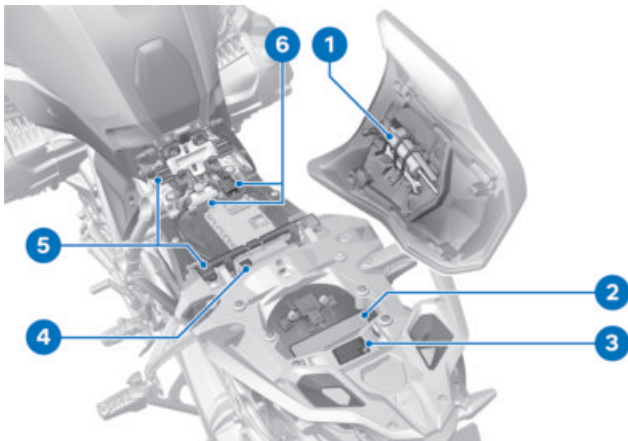

- 1 Toolkit (☞ 177)
- 2 Rider's Manual
- 3 Tyre pressures table
- 4 Payload table
- 5 Adjusting front-seat height
(☞ 124)
- 6 Fuses (☞ 203)

MULTIFUNCTION SWITCH, LEFT

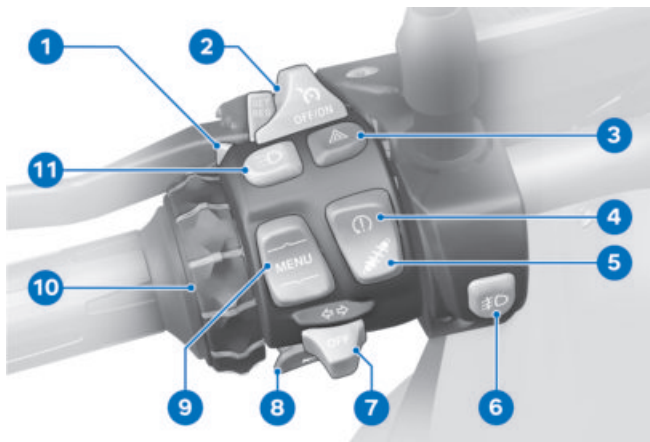

- | | |
|---|--|
| <p>1 High-beam headlight and headlight flasher (▣ 69)</p> <p>2 –with cruise control^{OE}
Adaptive cruise control (▣ 82).</p> <p>3 Hazard warning lights (▣ 72)</p> <p>4 DTC (▣ 73)</p> <p>5 –with Dynamic ESA^{OE}
Dynamic ESA possible settings (▣ 74)</p> <p>6 –with additional headlight^{OE}
Auxiliary headlights (▣ 70).</p> <p>7 Turn indicators (▣ 72)</p> <p>8 Horn</p> | <p>9 MENU rocker button (▣ 95)</p> <p>10 Multi-Controller Controls (▣ 95)</p> <p>11 –with daytime riding light^{OE}
Manual daytime riding light (▣ 70).</p> |
|---|--|

22 GENERAL VIEWS

MULTIFUNCTION SWITCH, RIGHT



–with intelligent emergency call^{OE}

- 1 Heating (☞ 90)
- 2 Riding mode (☞ 77)
- 3 Emergency-off switch (kill switch) (☞ 66)
- 4 Starter button
Start the engine (☞ 136).
- 5 SOS button
Intelligent emergency call (☞ 66)

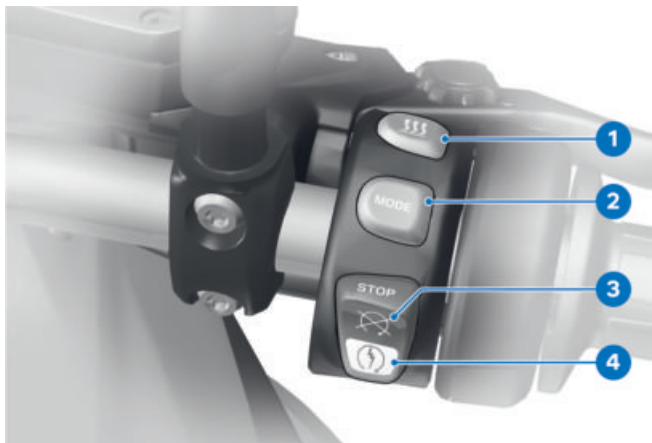
MULTIFUNCTION SWITCH, RIGHT

–without intelligent emergency call^{OE}

- 1** Heating (▮▮▮▶ 90)
- 2** Riding mode (▮▮▮▶ 77)
- 3** Emergency-off switch (kill switch) (▮▮▮▶ 66)
- 4** Starter button
Start the engine (▮▮▮▶ 136).

24 GENERAL VIEWS

INSTRUMENT CLUSTER



- 1 Indicator and warning lights (►► 28)
- 2 TFT display (►► 29)
(►► 30)
- 3 Alarm system LED
–with anti-theft alarm
(DWA)^{OE}
Alarm signal (►► 87)
–with Keyless Ride^{OE}
Indicator light for the radio-operated key
Ignition with Keyless Ride
(►► 63).
- 4 Photosensor (for adapting the brightness of the instrument lighting)

STATUS INDICAT- ORS

03

INDICATOR AND WARNING LIGHTS	28
TFT DISPLAY IN PURE RIDE VIEW	29
TFT DISPLAY IN MENU VIEW	30
WARNING INDICATORS	31

28 STATUS INDICATORS

INDICATOR AND WARNING LIGHTS

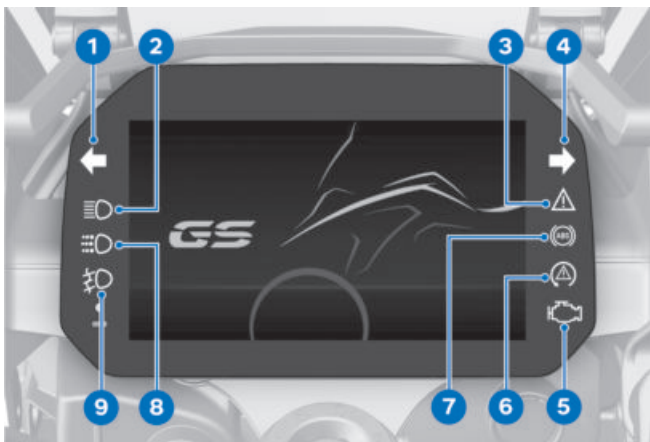

- 1 Turn indicators, left
Operate the turn indicators (▣▣▣ 72).
- 2 High-beam headlight (▣▣▣ 69)
- 3 General warning light (▣▣▣ 31)
- 4 Turn indicators, right
- 5 - with EU markets export^{NV}
Malfunction indicator lamp, drive
Drive malfunction (▣▣▣ 44)
- 6 DTC (▣▣▣ 52)
- 7 ABS (▣▣▣ 51)
- 8 -with daytime riding light^{OE}
Manual daytime riding light (▣▣▣ 70).
- 9 -with additional head-light^{OE}
Auxiliary headlights (▣▣▣ 70).

TFT DISPLAY IN PURE RIDE VIEW

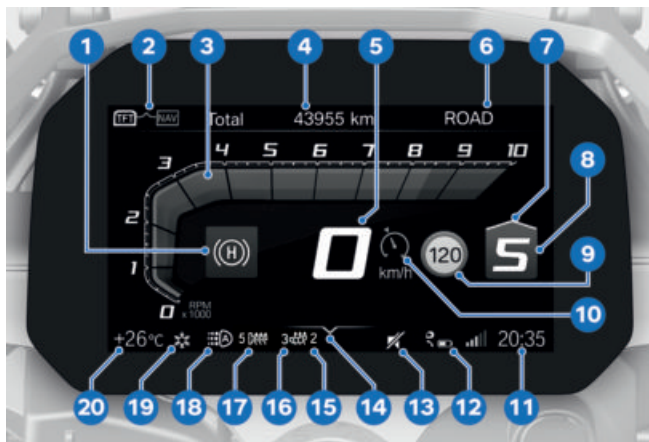

- | | |
|---|--|
| 1 Hill Start Control (►► 54) | 12 Connection status (►► 105) |
| 2 Change of operating focus (►► 99) | 13 Muting (►► 102) |
| 3 Rev. counter (►► 101) | 14 Operating help |
| 4 Driver info. status line (►► 99) | 15 Passenger seat heating (►► 91) |
| 5 Speedometer | 16 Rider's seat heating (►► 91) |
| 6 Riding mode (►► 77) | 17 Heated grips (►► 90) |
| 7 Recommendation to up-shift (►► 102) | 18 Automatic daytime riding light (►► 71) |
| 8 Gear indicator; "N" indicates neutral. | 19 Outside temperature warning (►► 38) |
| 9 Speed Limit Info (►► 101) | 20 Ambient temperature |
| 10 –with cruise control ^{OE} Adaptive cruise control (►► 82). | |
| 11 Clock (►► 103) | |

30 STATUS INDICATORS

TFT DISPLAY IN MENU VIEW

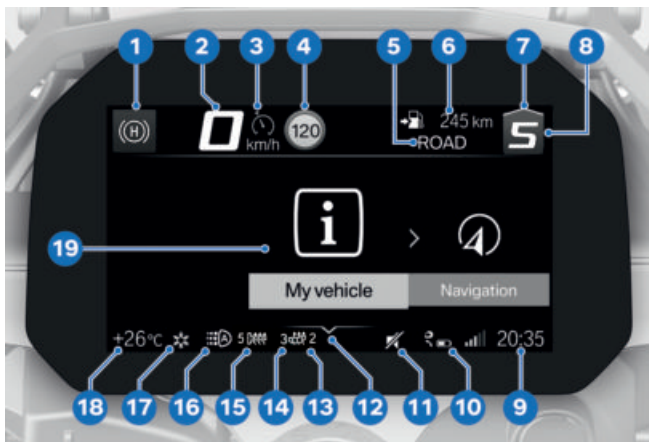

- | | |
|--|---|
| 1 Hill Start Control (►►► 54) | 13 Passenger seat heating (►►► 91) |
| 2 Speedometer | 14 Rider's seat heating (►►► 91) |
| 3 –with cruise control ^{OE}
Adaptive cruise control (►►► 82). | 15 Heated grips (►►► 90) |
| 4 Speed Limit Info (►►► 101) | 16 Automatic daytime riding light (►►► 71) |
| 5 Riding mode (►►► 77) | 17 Outside temperature warning (►►► 38) |
| 6 Driver info. status line (►►► 99) | 18 Ambient temperature |
| 7 Recommendation to up-shift (►►► 102) | 19 Menu section |
| 8 Gear indicator; "N" indicates neutral. | |
| 9 Clock | |
| 10 Connection status | |
| 11 Muting (►►► 102) | |
| 12 Operating help | |

WARNING INDICATORS

Mode of presentation

Warnings are indicated by the corresponding warning lights. Warnings are indicated by 'General' warning light showing in combination with a dialogue in the TFT display. The 'General' warning light shows yellow or red, depending on the urgency of the warning.



The status of the 'General' warning light matches the most urgent warning. The possible warnings are listed on the next pages.

- Green CHECK OK **1**: no message, optimum values.
- White circle with small "i" **2**: information.
- Yellow warning triangle **3**: warning, value not ideal.
- Red warning triangle **3**: warning, value critical

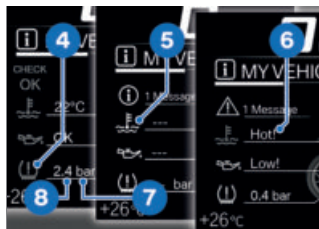

Values display

Symbols **4** differ in how they show on the display. The colours used differ and reflect the urgency of the message. Along with numerical values **8** with units **7**, texts **6** are displayed as well:

Colour of the symbol

- Green: (OK) Current value is ideal.
- Blue: (Cold!) Current temperature is too low.
- Yellow: (Low! / High!) Current value is too low or too high.
- Red: (Hot! / High!) Current temperature or value is too high.

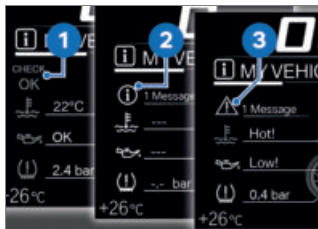

Check Control display

The messages differ in how they show on the display. Different colours and symbols are used depending on priority:

32 STATUS INDICATORS

–White: (---) No valid value available. Dashes **5** are displayed instead of a numerical value.

 The assessment of some values is only possible from a certain journey duration or speed. If a measured value is still not being displayed because the conditions for measurement have not been met, dashes are displayed instead as a placeholder. If there are no valid measured values, there will be no assessment in the form of a coloured symbol.

ledged by tilting the Multi-Controller to the left.

–Check Control messages are dynamically attached as additional tabs on the pages in the menu *My vehicle* ( 97). You can go to the message again as long as the fault persists.

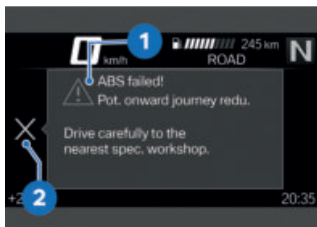





















Check Control dialogue



















Messages are output as Check Control dialogues **1**.

















- If there are two or more Check Control messages of equal priority, the messages keep changing in the order of their occurrence until they are acknowledged.
- If symbol **2** is actively displayed, it can be acknow-

Warnings, overview

















Indicator and warning lights	Display text	Meaning
	 is displayed.	Outside temperature warning (▶▶▶▶ 38)
 lights up yellow.	 Remote key not in range.	Radio-operated key out of range (▶▶▶▶ 38)
 lights up yellow.	 Remote key battery at 50%.	Replacing battery of remote key (▶▶▶▶ 39)
	 Remote key battery weak.	
 lights up yellow.	 is displayed in yellow.	Voltage of the vehicle electrical system too low (▶▶▶▶ 39)
	 Vehicle voltage low.	
 lights up red.	 is displayed in red.	Voltage of the vehicle electrical system critical (▶▶▶▶ 40)
	 Vehicle voltage critical!	
 lights up red.	 is displayed in red.	Charging voltage critical (▶▶▶▶ 40)
	 Vehicle voltage critical!	
 lights up yellow.	 The faulty bulb is displayed.	Bulb faulty (▶▶▶▶ 41)
	 Alarm system batt. capacity weak.	Anti-theft alarm battery weak (▶▶▶▶ 41)
 lights up yellow.	 Alarm system battery empty.	Anti-theft alarm battery flat (▶▶▶▶ 42)



34 STATUS INDICATORS

Indicator and warning lights	Display text	Meaning
	 Engine oil level. Check engine oil level.	Electronic oil-level check: Check the engine oil level (▣▣▣▣ 43)
 lights up red.	 Coolant temperature too high!	Coolant temperature too high (▣▣▣▣ 43)
 lights up.	 Engine!	Drive malfunction (▣▣▣▣ 44)
 flashes red.		Serious drive malfunction (▣▣▣▣ 44)
 flashes.		
 lights up yellow.	 No communication with engine control.	Engine control failed (▣▣▣▣ 44)
 lights up yellow.	 Fault in the engine control.	Engine in emergency-operation mode (▣▣▣▣ 44)
 flashes red.	 Serious fault in the engine control!	Severe fault in the engine control (▣▣▣▣ 45)
 lights up yellow.	 is displayed in yellow.	Tyre pressure in limit range of the permitted tolerance (▣▣▣▣ 47)
	 Tyre pressure does not match setpoint.	
 flashes red.	 is displayed in red.	Tyre pressure outside the permitted tolerance (▣▣▣▣ 47)
	 Tyre pressure does not match setpoint.	

Indicator and warning lights	Display text	Meaning
	 Tyre press. control. Loss of pressure.	Tyre pressure outside the permitted tolerance (▣▣▣ 47)
	 "----"	Transmission fault (▣▣▣ 48)
 lights up yellow.	 "----"	Sensor faulty or system fault (▣▣▣ 49)
 lights up yellow.	 RDC sensor battery weak.	Battery for tyre pressure sensor weak (▣▣▣ 49)
	 Drop sensor faulty.	Drop sensor defective (▣▣▣ 50)
	 Emergency call failure.	Emergency call function restricted (▣▣▣ 50)
	 Side stand monitoring faulty.	Side stand monitoring is faulty (▣▣▣ 50)
 flashes.		ABS self-diagnosis not completed (▣▣▣ 50)
 lights up.	 Limited ABS availability!	ABS fault (▣▣▣ 51)
 lights up.	 ABS failure!	ABS failed (▣▣▣ 51)
 lights up.	 ABS Pro failure!	ABS Pro failed (▣▣▣ 51)
 quick-flashes.		DTC intervention (▣▣▣ 52)

36 STATUS INDICATORS

Indicator and warning lights	Display text	Meaning
 slow-flashes.		DTC self-diagnosis not completed (▣▣▣ 52)
 lights up.	 Off!	DTC switched off (▣▣▣ 52)
	 Traction control deactivated.	
 lights up.	 Traction control limited!	DTC restricted (▣▣▣ 52)
 lights up.	 Traction control failure!	DTC fault (▣▣▣ 53)
 lights up yellow.	 Spring strut adjustment faulty!	D-ESA fault (▣▣▣ 53)
	 Fuel reserve reached. Go to a filling station soon	Fuel down to reserve (▣▣▣ 54)
	 Green holding symbol is displayed.	Hill Start Control active (▣▣▣ 54)
	 Yellow holding symbol flashes.	Hill Start Control automatically deactivated (▣▣▣ 54)
	 Crossed-out holding symbol is displayed.	Hill Start Control cannot be activated (▣▣▣ 55)
	 The gear indicator flashes.	Gear not trained (▣▣▣ 55)
 flashes green.		Hazard warning lights system is switched on (▣▣▣ 55)
 flashes green.		

Indicator and warning lights	Display text	Meaning
	 is displayed in white. Service due!	Service due (▶ 56)
 lights up yellow.	 is displayed in yellow. Service over-due!	Service-due date has passed (▶ 56)

–with Keyless Ride^{OE}

- Battery of the radio-operated key is empty or loss of the radio-operated key (➡ 64).
- If a check control dialogue box appears during the journey, remain calm. You can continue your journey; the engine will not switch off.
- Have the defective radio-operated key replaced by an authorised BMW Motorrad dealer.

Replacing battery of remote key

 lights up yellow.

 Remote key battery at 50%. No functional impairment.

 Remote key battery weak. Limited central locking function. Change battery.

Possible cause:

- The battery of the remote key has lost a significant proportion of its original capacity. The function of the remote key is only still ensured for a limited time.

–with Keyless Ride^{OE}

- Replace the battery of the radio-operated key (➡ 65).

Voltage of the vehicle electrical system too low

 lights up yellow.

 is displayed in yellow.

 Vehicle voltage low. Switch off unnecessary consumers.

The voltage of the vehicle electrical system is too low. If you continue to ride the motorcycle the on-board electronics will drain the battery.

Possible cause:

Consumers with high power consumption (such as heated body warmers) are in operation, too many consumers are in operation at one time, or battery faulty.

- Switch off non-essential consumers or disconnect them from the vehicle's electrical system.
- If the fault persists or occurs without consumers connected, have the fault rectified as quickly as possible by a specialist workshop, preferably an authorised BMW Motorrad retailer.

40 STATUS INDICATORS

Voltage of the vehicle electrical system critical

 lights up red.

 is displayed in red.

 Vehicle voltage critical! Consumers were switched off. Check battery condition.

WARNING

Failure of the vehicle systems

Risk of accident

- Do not continue your journey.

The voltage of the vehicle electrical system is critical. If you continue to ride the motorcycle the on-board electronics will drain the battery.

Possible cause:

Consumers with high power consumption (such as heated body warmers) are in operation, too many consumers are in operation at one time, or battery faulty.

- Switch off non-essential consumers or disconnect them from the vehicle's electrical system.
- If the fault persists or occurs without consumers connec-

ted, have the fault rectified as quickly as possible by a specialist workshop, preferably an authorised BMW Motorrad retailer.

Charging voltage critical

 lights up red.

 is displayed in red.

 Vehicle voltage critical! Battery is not being charged. Check battery status.

WARNING

Failure of the vehicle systems

Risk of accident

- Do not continue your journey.

The battery is not being charged. If you continue to ride the motorcycle the on-board electronics will drain the battery.

Possible cause:

The alternator or alternator drive is faulty, battery is faulty or the fuse for the alternator regulator has blown.

- Have the fault rectified as quickly as possible by a specialist workshop, preferably

an authorised BMW Motorrad dealer.

Bulb faulty

 lights up yellow.

 The faulty bulb is displayed:

 High beam faulty!

 Front left turn indicator faulty! or Front right turn indicator faulty!

 Low-beam headlight faulty!

 Front side light faulty!

–with daytime riding light^{OE}

 Daytime riding light faulty!<

–with additional headlight^{OE}

 Left additional headlight faulty! or Right additional headlight faulty!<

 Tail light faulty!

 Brake light faulty!

 Rear left turn indicator faulty! or Rear right turn indicator faulty!

 Number plate light faulty!

–Have it checked by a specialist workshop.

WARNING

Vehicle overlooked in traffic due to failure of the lights on the vehicle

Safety risk

- Always replace a faulty bulb at the earliest possible opportunity. Consult a specialist workshop, preferably an authorised BMW Motorrad Retailer.

Possible cause:

One or more bulbs faulty.

- Visually inspect to ascertain which bulb is defective.
- Have LED light sources replaced as complete units; consult a specialist workshop, preferably an authorised BMW Motorrad retailer.

Anti-theft alarm battery weak

–with anti-theft alarm (DWA)^{OE}

 Alarm system batt. capacity weak. No restrictions. Make an appointment at a specialist workshop.

42 STATUS INDICATORS

 This error message shows briefly only after the Pre-Ride-Check completes.

Possible cause:

The integral battery in the anti-theft alarm has lost a significant proportion of its original capacity. There is no assurance of how long the anti-theft alarm can remain operational if the vehicle's battery is disconnected.

- Seek the advice of a specialist workshop, preferably an authorised BMW Motorrad dealer.

Anti-theft alarm battery flat
—with anti-theft alarm (DWA)^{OE}

 lights up yellow.

 Alarm system battery empty. No independent alarm. Make an appointment at a specialist workshop.

 This error message shows briefly only after the Pre-Ride-Check completes.

Possible cause:

The integral battery in the anti-theft alarm has lost its entire original capacity. There is no assurance that the anti-theft alarm will be operational if the

vehicle's battery is disconnected.

- Seek the advice of a specialist workshop, preferably an authorised BMW Motorrad dealer.

Electronic oil-level check

 The electronic oil-level check assesses the oil level in the engine as OK or Low!

The following preconditions have to be satisfied for electronic oil-level checking, and several measurements might have to be taken:

- Rider is sitting on the vehicle and vehicle has just been ridden at a speed of at least 10 km/h.
- Engine idling for at least 20 seconds.
- Engine is at operating temperature.
- Vehicle is standing upright on a smooth, level surface.
- Side stand is retracted and vehicle is not propped on its centre stand.
- The spring strut is appropriately set for the load status, or D-ESA is in Auto load mode.

If measurement is incomplete or if these conditions are not met, the oil level cannot be

judged by the system. Dashes (---) appear on the display instead of a reading.

Electronic oil-level check: Check the engine oil level

 Engine oil level.
Check engine oil level.

Possible cause:

The electronic oil-level sensor has registered a low oil level. If the vehicle is not standing upright on a smooth, level surface, the message might appear even though the oil level is correct. The next time you stop for fuel:

- Check the engine oil level (▣▣▣▣▶ 179).

If the oil level in the sight glass is too low:

- Top up the engine oil (▣▣▣▣▶ 180).

When the oil level in the sight glass is correct:

- Check whether the preconditions for the electronic oil-level check are met.

If the message appears repeatedly, even though the oil level is slightly below the maximum mark:

- Seek the advice of a specialist workshop, preferably an authorised BMW Motorrad dealer.

Coolant temperature too high



lights up red.



Coolant temperature too high! Check coolant level. Continue driving in part. load to cool down.



ATTENTION

Riding with overheated engine

Engine damage

- Compliance with the information set out below is essential.

Possible cause:

The coolant level is too low.

- Check the coolant level (▣▣▣▣▶ 185).

If the coolant level is too low:

- Leave the engine to cool down.
- Topping up coolant (▣▣▣▣▶ 186).
- Have the cooling system checked by a specialist workshop, preferably by a BMW Motorrad partner.

Possible cause:

The coolant temperature is too high.

- If possible, ride in the part-load range to cool down the engine.

44 STATUS INDICATORS

If the coolant temperature is frequently too high:

- Have the fault rectified as quickly as possible by a specialist workshop, preferably an authorised BMW Motorrad dealer.

Drive malfunction



lights up.



Engine! Have it checked by a specialist workshop.

Possible cause:

The engine control unit has diagnosed a fault which affects the pollutant emissions.

- Have the fault rectified by a specialist workshop, preferably an authorised BMW Motorrad dealer.
- » You can continue riding; pollutant emissions are higher than the threshold values.

Serious drive malfunction



flashes red.



flashes.

Possible cause:

The engine control unit has diagnosed a fault that can lead to damage to the exhaust system.

- Have the fault rectified as quickly as possible by a specialist workshop, preferably an authorised BMW Motorrad retailer.
- » It is possible to continue to ride but not recommended.

Engine control failed



lights up yellow.



No communication with engine control. Multiple sys. affected. Ride carefully to the next specialist workshop.

Engine in emergency-operation mode



lights up yellow.



Fault in the engine control. Onward journey possible. Ride carefully to next specialist workshop.

**WARNING****Unusual ride characteristics when engine running in emergency-operation mode**

Risk of accident

- Avoid accelerating sharply and overtaking.

Possible cause:

The engine control unit has diagnosed a fault which impairs the engine performance or throttle response. The engine is in emergency-operation mode. In exceptional cases, the engine stops and refuses to start.

- Have the fault rectified as quickly as possible by a specialist workshop, preferably an authorised BMW Motorrad dealer.
- » It is possible to continue riding, however the engine performance and engine speed range may be impaired and not function as normal.

Severe fault in the engine control

flashes red.



Serious fault in the engine control! Riding at mod. speed pos.

Damage possible. Have checked by workshop.

**WARNING****Engine damage when running in emergency-operation mode**

Risk of accident

- Ride slowly, avoid accelerating sharply and overtaking.
- If possible, have the vehicle picked up and have the fault rectified by a specialist workshop, preferably an authorised BMW Motorrad Retailer.

Possible cause:

The engine control unit has diagnosed a fault which may cause severe secondary faults. The engine is in emergency-operation mode.

- It is possible to continue to ride but not recommended.
- Avoid high load and rpm ranges if possible.
- Have the fault rectified as quickly as possible by a specialist workshop, preferably an authorised BMW Motorrad dealer.

46 STATUS INDICATORS

Tyre pressure

—with tyre pressure control (RDC)^{OE}

In addition to the MY VEHICLE menu screen and the Check Control messages, there is also the TYRE PRESSURE screen for showing the tyre pressures:

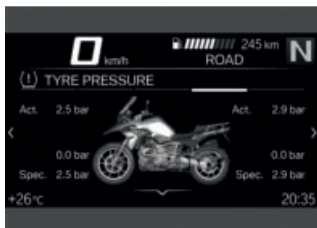

The values on the left are for the front wheel; those on the right are for the rear wheel. Actual and specified tyre pressures and the difference between them are displayed for each wheel. Immediately after the ignition is switched on, only dashes are displayed. The sensors do not start transmitting tyre pressure signals until the first time the vehicle accelerates to more than the minimum speed stated below:



RDC sensor is not active

min 30 km/h (The RDC sensor does not transmit its signal to the vehicle until a certain minimum speed has been reached.)



The tyre pressures are shown in the TFT display as temperature compensated and always refer to the following tyre air temperature:

20 °C



If the tyre symbol appears as well, showing yellow or red, this is a warning. The pressure difference is highlighted with an exclamation mark in the same colour.



If the value in question is close to the limit of the permissible tolerance range, the reading is accompanied by the 'General' warning light showing yellow.



The 'General' warning light flashes red if the tyre pressure registered by the sensor is outside the permissible tolerance range.

For further information about BMW Motorrad RDC see the section entitled "Engineering details" from page (▣▣▣ 166) onward.

Tyre pressure in limit range of the permitted tolerance

–with tyre pressure control (RDC)^{OE}



lights up yellow.



is displayed in yellow.



Tyre pressure does not match setpoint

Check tyre pressure.

Possible cause:

Measured tyre pressure is close to the limit of permitted tolerance.

- Correct tyre pressure.
- Before adjusting the tyre pressure, observe the information on temperature compensation and pressure adaptation in the section entitled "Engineering details":

» Temperature compensation (▣▣▣ 167)

» Pressure adaptation (▣▣▣ 167)

» Find the correct tyre pressures in the following places:

–On the back cover of the rider's manual

–Instrument cluster in the TYRE PRESSURE view

–Sign under the seat

Tyre pressure outside the permitted tolerance

–with tyre pressure control (RDC)^{OE}



flashes red.



is displayed in red.



Tyre pressure does not match setpoint

Stop immediately! Check tyre pressure.



Tyre press. control. Loss of pressure.

Stop immediately! Check tyre pressure.



WARNING

Tyre pressure outside the permitted tolerance.

Risk of accident, degradation of the vehicle's driving characteristics.

- Adapt your style of riding accordingly.

48 STATUS INDICATORS

Possible cause:

Measured tyre pressure is outside permitted tolerance.

- Check the tyre for damage and to ascertain whether the vehicle can be ridden with the tyre in its present condition.

If the vehicle can be ridden with the tyre in its present condition:

- Correct the tyre pressure at the earliest possible opportunity.
- Before adjusting the tyre pressure, observe the information on temperature compensation and pressure adaptation in the section entitled "Engineering details":
 - » Temperature compensation (▶▶▶ 167)
 - » Pressure adaptation (▶▶▶ 167)
 - » Find the correct tyre pressures in the following places:
 - On the back cover of the rider's manual
 - Instrument cluster in the **TYRE PRESSURE** view
 - Sign under the seat
- Have the tyre checked for damage by a specialist workshop, preferably an authorised BMW Motorrad Retailer.

 You can deactivate RDC warnings for riding in off-road mode.

If you are unsure whether the vehicle can be ridden with the tyre in its present condition:

- Do not continue your journey.
- Notify the breakdown service.

Transmission fault

–with tyre pressure control (RDC)^{OE}



"---"

Possible cause:

The vehicle has not reached the minimum speed (▶▶▶ 166).



RDC sensor is not active

min 30 km/h (The RDC sensor does not transmit its signal to the vehicle until a certain minimum speed has been reached.)

- Observe the RDC display at higher speeds.



Assume that a permanent fault has not occurred unless the 'General' warning light comes on to accompany the symptoms.

Under these circumstances:

- Have the fault rectified by a specialist workshop, preferably an authorised BMW Motorrad dealer.

Possible cause:

The radio link to the RDC sensors is faulty. Radio systems are located in the surrounding area which are interfering with the transmission between the RDC control unit and the sensors.

- Observe the RDC displays in other surrounding areas.

 Assume that a permanent fault has not occurred unless the 'General' warning light comes on to accompany the symptoms.

Under these circumstances:

- Have the fault rectified by a specialist workshop, preferably an authorised BMW Motorrad dealer.

Sensor faulty or system fault

—with tyre pressure control (RDC)^{OE}

 lights up yellow.

 "----"

Possible cause:

Vehicle is fitted with wheels not equipped with RDC sensors.

- Fit wheels and tyres equipped with RDC sensors.

Possible cause:

1 or 2 RDC sensors have failed or a system error has occurred.

- Have the fault rectified by a specialist workshop, preferably an authorised BMW Motorrad dealer.

Battery for tyre pressure sensor weak

—with tyre pressure control (RDC)^{OE}

 lights up yellow.

 RDC sensor battery weak. Function limited. Have it checked by a specialist workshop.

 This error message shows briefly only after the Pre-Ride-Check completes.

Possible cause:

The integral battery in the tyre-pressure sensor has lost a significant proportion of its original capacity. There is no assurance of how long the tyre pressure control system can remain operational.

- Seek the advice of a specialist workshop, preferably an authorised BMW Motorrad dealer.

50 STATUS INDICATORS

Drop sensor defective

 Drop sensor faulty. Have it checked by a specialist workshop.

Possible cause:

The drop sensor is not available.

- Seek the advice of a specialist workshop, preferably an authorised BMW Motorrad dealer.

Emergency call function restricted

—with intelligent emergency call^{OE}

 Emergency call failure. Make an appointment at a specialist workshop.

Possible cause:

The emergency call cannot be made automatically or via BMW.

- Observe information on operating the intelligent emergency call from page (➔ 66).
- Seek the advice of a specialist workshop, preferably an authorised BMW Motorrad dealer.

Side stand monitoring is faulty

 Side stand monitoring faulty. Onward journey possible.

Engine stop. when stationary! Have checked by workshop.

Possible cause:

The side-stand switch or its wiring are damaged. The engine is shut down when speed drops below 5 km/h and you cannot resume your journey.

- Consult a specialist workshop, preferably an authorised BMW Motorrad retailer.

ABS self-diagnosis not completed

 flashes.

Possible cause:

 ABS self-diagnosis not completed

The ABS function is not available, because self-diagnosis did not complete. (The motorcycle has to reach a defined minimum speed for the wheel speed sensors to be checked: 5 km/h)

- Pull away slowly. Bear in mind that the ABS function is not available until self-diagnosis has completed.

ABS fault

lights up.



Limited ABS availability! Onward journey possible. Ride carefully to next specialist workshop.

Possible cause:

The ABS control unit has detected a fault. The partially integral function and the Dynamic Brake Control function have failed. The ABS function has limited availability.

- You can continue to ride. Pay attention to the more detailed information on certain situations that can lead to an ABS fault message (▶▶▶ 156).
- Have the fault rectified as quickly as possible by a specialist workshop, preferably an authorised BMW Motorrad Retailer.

ABS failed

lights up.



ABS failure! Onward journey possible. Ride carefully to next specialist workshop.

Possible cause:

The ABS control unit has detected a fault. The ABS function is not available.

- You can continue to ride. Bear in mind the more detailed information on certain situations that can lead to an ABS fault message (▶▶▶ 156).
- Have the fault rectified as quickly as possible by a specialist workshop, preferably an authorised BMW Motorrad retailer.

ABS Pro failed

lights up.



ABS Pro failure! Onward journey possible. Ride carefully to next specialist workshop.

Possible cause:

Monitoring of the ABS Pro function has detected a fault. The ABS Pro function is not available. The ABS function is still available. ABS provides support only for braking in straight-ahead driving.

- You can continue to ride. Bear in mind the more detailed information on certain situations that can

52 STATUS INDICATORS

lead to an ABS Pro fault message (►► 156).

- Have the fault rectified as quickly as possible by a specialist workshop, preferably an authorised BMW Motorrad retailer.

DTC intervention



quick-flashes.

The DTC has detected a degree of instability at the rear wheel and has intervened to reduce torque. The indicator light flashes for longer than the DTC intervention lasts. This affords the rider visual feedback on control intervention even after the critical situation has been dealt with.

DTC self-diagnosis not completed



slow-flashes.

Possible cause:



DTC self-diagnosis not completed

The DTC function is not available, because self-diagnosis did not complete. (The motorcycle has to reach a defined minimum speed with the engine running for the wheel-speed sensors to be checked: min 5 km/h)

- Pull away slowly. The DTC indicator light must go out within a few metres.

If the DTC indicator light continues flashing:

- Consult a specialist workshop, preferably an authorised BMW Motorrad retailer.

DTC switched off



lights up.



Off!



Traction control deactivated.

Possible cause:

The rider has switched off the DTC system.

- Switch on the DTC function (►► 74).

DTC restricted



lights up.



Traction control limited! Onward journey possible.

Ride carefully to next specialist workshop.

Possible cause:

The DTC control unit has detected a fault.

**ATTENTION****Damaged components**

Damage to sensors, for example, which causes malfunctions

- Do not transport any objects underneath the driver or passenger seat.
 - Secure the toolkit.
- Do not damage the angular rate sensor.
 - Bear in mind that the DTC function is restricted.
 - You can continue to ride. Bear in mind the more detailed information on situations that can lead to a DTC fault (►► 158).
 - Have the fault rectified as quickly as possible by a specialist workshop, preferably an authorised BMW Motorrad retailer.

DTC fault

lights up.



Traction control failure! Onward journey possible. Ride carefully to next specialist workshop.

Possible cause:

The DTC control unit has detected a fault.

**ATTENTION****Damaged components**

Damage to sensors, for example, which causes malfunctions

- Do not transport any objects underneath the driver or passenger seat.
 - Secure the toolkit.
- Do not damage the angular rate sensor.
 - Bear in mind that the DTC function is not available or the functionality is subject to certain restrictions.
 - You can continue to ride. Bear in mind the more detailed information on situations that can lead to a DTC fault (►► 158).
 - Have the fault rectified as quickly as possible by a specialist workshop, preferably an authorised BMW Motorrad retailer.

D-ESA fault

lights up yellow.



Spring strut adjustment faulty! Onward journey possible. Ride

54 STATUS INDICATORS

carefully to next specialist workshop.

Possible cause:

The D-ESA control unit has detected a fault. The damping and/or spring adjuster may be the cause. In Auto the cause may also be a fault in the riding position equaliser. In this condition, the motorcycle may have too much damping and is uncomfortable to drive, especially on roads in poor condition. Alternatively, the spring preload may be incorrectly adjusted.

- Have the fault rectified as quickly as possible by a specialist workshop, preferably an authorised BMW Motorrad dealer.

Fuel down to reserve

 Fuel reserve reached. Go to a filling station soon.



WARNING

Irregular engine operation or engine shutdown due to lack of fuel

Risk of accident, damage to catalytic converter

- Do not run the fuel tank dry.

Possible cause:

The fuel tank contains no more than the reserve quantity of fuel.

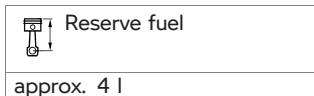

- Refuelling (▶▶▶ 146).

Hill Start Control active

 Green holding symbol is displayed.

Possible cause:

The driver has activated Hill Start Control (▶▶▶ 169).

- Switch off Hill Start Control.
- Operate Hill Start Control (▶▶▶ 84).

Hill Start Control automatically deactivated

 Yellow holding symbol flashes.

Possible cause:

Hill Start Control has been automatically deactivated.

- Side stand has been folded out.
 - » Hill Start Control is deactivated when the side stand is folded out.
- Engine has been switched off.
 - » Hill Start Control is deactivated when the engine is switched off.
- Operate Hill Start Control (▶▶▶ 84).

Hill Start Control cannot be activated



Crossed-out holding symbol is displayed.

Possible cause:

Hill Start Control cannot be activated.

- Retract the side stand.
- » Hill Start Control functions only when the side stands are folded in.
- Start the engine.
- » Hill Start Control functions only when the engine is running.

Gear not trained

—with shift assistant Pro^{OE}



The gear indicator flashes. The Pro shift assistant is not available.

Possible cause:

—with shift assistant Pro^{OE}

The gearbox sensor is not fully trained.

- Select neutral N and allow the engine to idle for at least 10 seconds to teach the neutral position.
- Use clutch control to engage each gear in turn and ride for a minimum of 10 seconds in each gear.
- » The gear indicator stops flashing when the gearbox sensor has been trained successfully.

—When the gearbox sensor is fully trained, the Gear Shift Assistant Pro functions as described (▮▮▮ 168).

- If teaching is not successful, have the fault rectified by a specialist workshop, preferably an authorised BMW Motorrad retailer.

Hazard warning lights system is switched on



flashes green.



flashes green.

Possible cause:

The driver has switched on the hazard warning lights system.

- Operating hazard warning flashers (▮▮▮ 72).

Service-due indicator



If service is overdue, the due date or the odometer reading at which service was due is accompanied by the 'General' warning light showing yellow.

If the service is overdue, a yellow CC message is displayed. Exclamation marks also draw your attention to the displays for service, service appointment and countdown distance in the MY VEHICLE and SERVICE REQUIREMENTS menu screens.

56 STATUS INDICATORS

 If the service-due indicator appears more than a month before the service date, the current date has to be corrected. This situation can occur if the battery was disconnected.

Service due

 is displayed in white.

Service due! Have service performed by a specialist workshop. Possible cause:

Service is due because of the driving performance or the date.

- Have your motorcycle serviced regularly by a specialist workshop, preferably by an authorised BMW Motorrad retailer.
- » The operational and road safety of the motorcycle remain intact.
- » The motorcycle's value is maintained as best as possible.

Service-due date has passed

 lights up yellow.

 is displayed in yellow.

Service overdue! Have service performed by a specialist workshop. Possible cause:

Service is overdue because of the driving performance or the date.

- Have your motorcycle serviced regularly by a specialist workshop, preferably by an authorised BMW Motorrad retailer.
- » The operational and road safety of the motorcycle remain intact.
- » The motorcycle's value is maintained as best as possible.

OPERATION

04

IGNITION SWITCH/STEERING LOCK	60
IGNITION WITH KEYLESS RIDE	62
EMERGENCY-OFF SWITCH (KILL SWITCH)	66
INTELLIGENT EMERGENCY CALL	66
LIGHTS	69
DAYTIME RIDING LIGHT	70
HAZARD WARNING LIGHTS	72
TURN INDICATORS	72
TRACTION CONTROL (DTC)	73
ELECTRONIC SUSPENSION ADJUSTMENT (D-ESA)	74
RIDING MODE	77
PRO RIDING MODE	80
ADAPTIVE CRUISE CONTROL	81
HILL START CONTROL	84
ANTI-THEFT ALARM (DWA)	87
TYRE PRESSURE CONTROL (RDC)	90
HEATING	90

60 OPERATION

IGNITION SWITCH/STEERING LOCK

Keys

You receive 2 vehicle keys. If a key is lost or mislaid, consult the notes on the electronic immobiliser (EWS) (▮▮▮ 61). Ignition switch/steering lock, fuel filler cap lock and seat lock are all operated with the same ignition key.

If you wish you can arrange to have the cases and the topcase fitted with locks that can be opened with the ignition key as well. Consult a specialist workshop, preferably an authorised BMW Motorrad retailer.

Engaging steering lock

- Turn the handlebars all the way to the left.

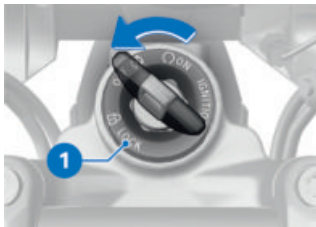

- Turn the ignition key to position **1**, while moving the handlebars slightly.

- » Ignition, lights and all function circuits switched off.
- » Handlebars are locked.
- » Vehicle key can be removed.

Switching on ignition



- Insert the vehicle key into the ignition switch and turn it to position **1**.
 - » Side lights and all function circuits are switched on.
 - » Pre-Ride-Check is performed. (▮▮▮ 137)
 - » ABS self-diagnosis is in progress. (▮▮▮ 137)
 - » DTC self-diagnosis is in progress. (▮▮▮ 138)

Welcome lights

- Switch on the ignition.
 - » The side lights briefly light up.
 - with daytime riding light^{OE}
 - » The daytime riding lights briefly light up.◁
 - with additional headlight^{OE}
 - » The auxiliary headlights light up briefly.◁

Switching off ignition



- Turn the ignition key to position **1**.
 - » When the ignition is switched off, the instrument cluster remains switched on for a short time and displays any existing fault messages.
 - » Handlebars not locked.
 - » Electrically powered accessories remain operational for a limited period of time.
 - » The battery can be recharged via the socket.
 - » Vehicle key can be removed.
- with daytime riding light^{OE}
 - The daytime riding light goes out soon after the ignition is switched off.<
- with additional headlight^{OE}
 - The auxiliary headlights go out soon after the ignition is switched off.<

Electronic immobiliser (EWS)

The on-board electronics access the data saved in the ignition key via a ring aerial in the ignition lock. The ignition is not enabled for starting until the engine control unit has recognised this ignition key as "authorised" for your motorcycle.



A second ignition key attached to the same ring as the ignition key used to start the engine could "irritate" the electronics, in which case the enabling signal for starting is not issued.

Always keep the ignition keys separate from each other.

If you lose your key, you can have it barred by your authorised BMW Motorrad retailer. If you wish to do this, you will need to bring all other keys for the motorcycle with you. The engine cannot be started by a barred ignition key, but an ignition key that has been barred can subsequently be reactivated.

You can obtain extra keys only through an authorised BMW Motorrad retailer. The ignition keys are part of an integrated security system, so the retailer is under an

62 OPERATION

obligation to check the legitimacy of all applications for replacement/extra keys.

IGNITION WITH KEYLESS RIDE

—with Keyless Ride^{OE}

Keys

 The telltale light for the radio-operated key flashes while the search for the radio-operated key is in progress. The light goes out as soon as the radio-operated key or the emergency key is found. The light goes out briefly if the search times out without the radio-operated key or the emergency key being found.

You receive one radio-operated key and one spare key. If a key is lost or mislaid, consult the notes on the electronic immobiliser (EWS) (► 61).

Ignition, fuel filler cap and anti-theft alarm system all work with the radio-operated key. Seat lock, topcase and cases can be locked and unlocked manually.

 The vehicle cannot be started if the radio control key is not within range (e.g. key inside one of the cases or the topcase).

If the radio-operated key re-

mains out of range, the ignition is switched off after about 1.5 minutes to protect the battery. It is advisable to keep the radio-operated key on your person (e.g. in a jacket pocket) and to have the emergency key with you as an alternative.

	Range of the Keyless Ride radio-operated key
—with Keyless Ride ^{OE}	
approx. 1 m<	

Engaging steering lock Requirement

Handlebars are turned to the left. Radio-operated key is within range.



- Press and hold down button **1**.
- » The steering lock engages with an audible click.
- » Ignition, lights and all function circuits switched off.
- Short-press button **1** to disengage the steering lock.

Switching on ignition Requirement

Radio-operated key is within range.



- There are **two** ways of activating the ignition.

Version 1:

- Briefly press button **1**.
 - » Side lights and all function circuits are switched on.
 - with daytime riding light^{OE}
 - » Daytime riding light is switched on.<
 - with additional headlight^{OE}
 - » Auxiliary headlights are switched on.<
 - » Pre-Ride-Check is performed. (▶▶▶ 137)
 - » ABS self-diagnosis is in progress. (▶▶▶ 137)

Version 2:

- Steering lock is engaged; press and hold down button **1**.
 - » The steering lock disengages.
 - » Side lights and all function circuits switched on.

- » Pre-Ride-Check is performed. (▶▶▶ 137)
- » ABS self-diagnosis is in progress. (▶▶▶ 137)

Switching off ignition Requirement

Radio-operated key is within range.



- There are **two** ways of deactivating the ignition.

Version 1:

- Briefly press button **1**.
 - » Light is switched off.
 - » Handlebars (steering lock) are not locked.

Version 2:

- Turn the handlebars all the way to the left.
- Press and hold down button **1**.
 - » Light is switched off.
 - » The steering lock engages.

64 OPERATION

Electronic immobiliser EWS

The on-board electronics access the data saved in the radio-operated key via a ring aerial in the R/C ignition lock. The ignition is not enabled for starting until the engine control unit has recognised the radio-operated key as "authorised" for your motorcycle.

 A second radio-operated key attached to the same ring as the radio-operated key used to start the engine could "irritate" the electronics, in which case the enabling signal for starting is not issued. Always keep the radio-operated keys separate from each other.

If you lose a radio-operated key, you can have it barred by your authorised BMW Motorrad retailer. If you wish to do this, you will need to bring all other keys for the motorcycle with you.

The engine cannot be started by a barred radio-operated key, but a radio-operated key that has been barred can subsequently be reactivated. You can obtain extra keys only through an authorised BMW Motorrad retailer. The radio-operated keys are part

of an integrated security system, so the retailer is under an obligation to check the legitimacy of all applications for replacement/extra keys.

Battery of the radio-operated key is empty or loss of the radio-operated key

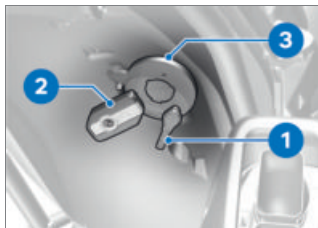

- If a key is lost or mislaid, consult the notes on the electronic immobiliser (**EWS**).
- If you happen to lose or mislay the radio-operated key while on a journey, you can start the vehicle with the spare key.
- If the battery of the radio-operated key is empty, the engine can be started by touching the radio-operated key against the rear-wheel cover.
- Hold spare key **1** or radio-operated key with empty battery **2** against the rear wheel cover at the location of aerial **3**.

 The spare key or the radio-operated key with the empty battery must be **in contact with** the rear-wheel cover.

 Time during which the engine has to be started. The unlocking procedure has to be repeated if this time is allowed to expire.

30 s

- » Pre-Ride-Check is performed.
- Radio-operated key has been recognised.
- Engine can be started.
- Start the engine (➡ 136).

Replacing battery of radio-operated key

If the radio-operated key does not react when you short-press or long-press a button:

- Battery of the radio-operated key is not at full capacity.



Remote key battery weak. Limited central locking function. Change battery.

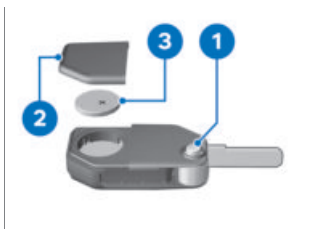

- Press button **1**.
- » Key bit flips out.
- Push battery cover **2** up.
- Remove battery **3**.
- Dispose of the old battery in accordance with all applicable laws and regulations; do not attempt to dispose of batteries as domestic waste.



ATTENTION

Unsuitable or incorrectly inserted batteries

Component damage

- Use a battery compliant with the manufacturer's specifications.
- When inserting the battery, always make sure polarity is correct.
- Insert the new battery with the positive terminal up.



Battery type

For Keyless Ride radio-operated key

66 OPERATION



Battery type

CR 2032

- Install battery cover **2**.
- » Red LED in the instrument cluster flashes.
- » The radio-operated key is again ready for use.

EMERGENCY-OFF SWITCH (KILL SWITCH)



- 1** Emergency-off switch (kill switch)



WARNING

Operation of the kill switch while riding

Risk of fall due to rear wheel locking

- Do not operate the kill switch when riding.

The emergency off switch is a kill switch for switching off the engine quickly and easily.



- A** Engine switched off
B Normal operating position (run)

INTELLIGENT EMERGENCY CALL

–with intelligent emergency call^{OE}

Emergency call via BMW

Press the SOS button in an emergency only. Even if an emergency call using BMW is not possible, the system may make an emergency call to a public emergency call number. This depends on the respective mobile phone network and the national regulations.

The emergency call is not able to be ensured because of technical reasons due to unfavourable conditions, e.g. in areas where there is no mobile phone reception.

Language for emergency call

Each vehicle has a language assigned to it depending on the market for which it is intended. The BMW Call Center answers in this language.

 The language for the emergency call can only be changed by the BMW Motorrad partner. The language assigned to the vehicle differs from the display languages that can be selected by the rider in the TFT display.

Manual emergency call Requirement

An emergency call has occurred. The vehicle is at a standstill. The ignition is switched on.

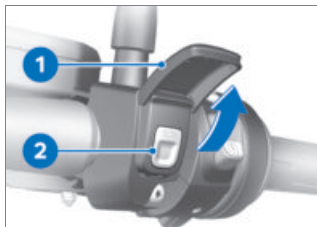

- Open cover **1**.
- Briefly press SOS button **2**.

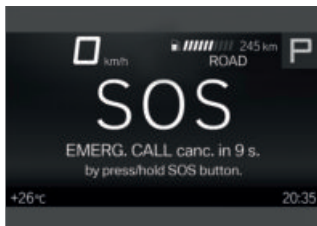

The time until transmission of the emergency call is displayed. During that time, it is possible to cancel the emergency call.

- Operate the emergency-off switch to stop the engine.
- Remove helmet.
- » After expiry of the timer, a voice contact to the BMW Call Center is established.

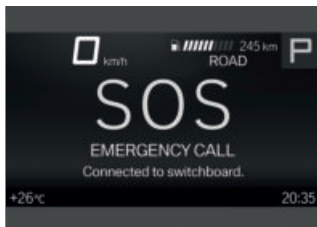

The connection was established.

68 OPERATION



- Provide information to the emergency services using the microphone **3** and speaker **4**.

Automatic emergency call

The intelligent emergency call is active after the ignition is switched on and reacts if a fall or crash occurs.

Emergency call in the event of a light fall

- A minor fall or a crash is detected.
- » An acoustic signal is sounded.

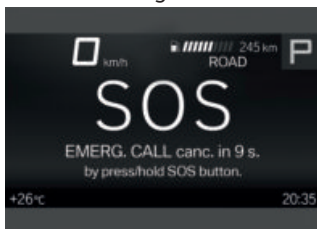

The time until transmission of the emergency call is displayed. During that time, it is possible to cancel the emergency call.

- If possible, remove helmet and stop engine.
- » A voice contact connection to the BMW Call Center is established.

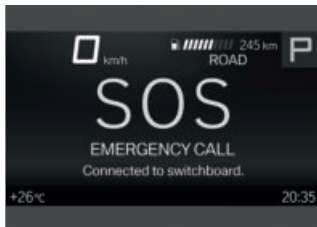

The connection was established.

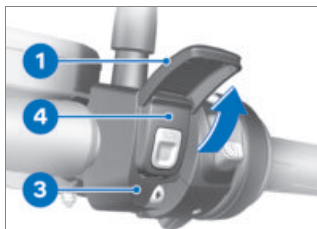

- Open cover **1**.
- Provide information to the emergency services using the microphone **3** and speaker **4**.

Emergency call in the event of a severe fall

- A severe fall or a crash is detected.
- » The emergency call is placed automatically without delay.

LIGHTS

Low-beam headlight and sidelights

The side lights switch on automatically when the ignition is switched on.

 The side lights place a strain on the battery. Do not switch the ignition on for longer than absolutely necessary.

The low-beam headlight switches on automatically when the engine is started.

—with daytime riding light^{OE}
In daytime the daytime riding light can be switched on as an alternative to the low-beam headlight.

High-beam headlight and headlight flasher

- Switch on the ignition (▮▮▮▮ 60).

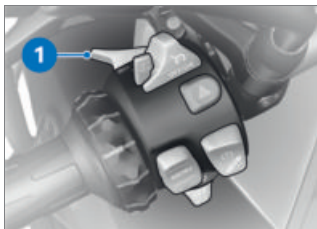

- Push switch **1** forward to switch on the high-beam headlight.

- Pull switch **1** back to operate the headlight flasher.

Headlight courtesy delay feature

- Switch off the ignition.



- Immediately after switching off the ignition, pull switch **1** back and hold it in that position until the headlight courtesy delay feature comes on.
 - » The vehicle's lights come on for one minute and then switch off automatically.
- This can be used to light up the path to the house door after the vehicle has been parked, for example.

Parking lights

- Switch off the ignition (▮▮▮▮ 61).

70 OPERATION



- Immediately after switching off the ignition, push button **1** to the left and hold it in that position until the parking lights come on.
- Switch the ignition on and off again to switch off the parking lights.

Auxiliary headlights

–with additional headlight^{OE}

Requirement

The auxiliary headlights are active only when the low-beam headlight is active.

 The auxiliary headlights have approval as fog lights and their use is permissible in bad weather conditions only. Always comply with the road traffic regulations in force in the country in which the vehicle is used.

- Start the engine (➡ 136).



- Press button **1** to switch on the auxiliary headlights.
 The indicator light for the auxiliary headlight illuminates.
- Press button **1** again to switch off the auxiliary headlights.

DAYTIME RIDING LIGHT

–with daytime riding light^{OE}

Manual daytime riding light Requirement

Automatic daytime riding light is switched off.



WARNING

Switching on the daytime riding light in the dark.

Risk of accident

- Do not use the daytime riding light in the dark.

 By comparison with the low-beam headlight, the daytime running light makes the vehicle more visible to on-

72 OPERATION

» If the ambient brightness decreases below a certain value, the low beam headlight is automatically switched on (e. B. in a tunnel). When sufficient ambient brightness is detected, the daytime riding light is switched back on.

 The indicator light for the daytime riding light shows if the daytime riding light is active.

Manual operation of the light when the automatic system is switched on

- If you press the button for the daytime riding light the daytime riding light is switched off and the low-beam headlight and front side lights are switched on (e. g. when you ride into a tunnel, and the response of the automatic daytime riding light to the change in ambient brightness is delayed).
- If you press the button again the daytime riding light is reactivated, in other words the daytime riding light is switched on again when ambient light is bright enough.

HAZARD WARNING LIGHTS

Operating hazard warning flashers

- Switch on the ignition (☛ 60).

 The hazard warning flashers place a strain on the battery. Do not use the hazard warning flashers for longer than absolutely necessary.



- Press button **1** to switch on the hazard warning lights system.
- » Ignition can be switched off.
- To switch off the hazard warning lights system, switch on the ignition if necessary and press button **1** again.

TURN INDICATORS

Operating turn indicators

- Switch on the ignition (☛ 60).



- Push button **1** to the left to switch on the left turn indicators.
- Push button **1** to the right to switch on the right turn indicators.
- Centre button **1** to cancel the turn indicators.

Comfort turn indicator



If button **1** has been pressed to the right or left, the turn indicators are automatically switched off under the following circumstances:

- Speed below 30 km/h: after 50 m distance covered.
- Speed between 30 km/h and 100 km/h: after a speed-dependent distance covered or in case of acceleration.
- Speed over 100 km/h: after flashing five times.

If button **1** is pressed to the right or left slightly longer, the turn indicators only switch off automatically once the speed-dependent distance covered is reached.

TRACTION CONTROL (DTC)

Switch off the DTC function

- Switch on the ignition (III 60).

 Dynamic Traction Control (DTC) can also be switched off when the motorcycle is in motion.



- Press and hold down button **1** until the DTC indicator light changes status. Immediately after button **1** is pressed, DTC system status ON

74 OPERATION

and current ABS system status are displayed.

 lights up.

Possible DTC system status OFF! is displayed.

- Release button **1** after the DTC system status changes. The new DTC system status OFF! appears briefly on the display. The ABS system status remains unchanged.

 remains lit.

» The DTC function is switched off.

Switch on the DTC function



- Press and hold down button **1** until the DTC indicator light changes status. Immediately after button **1** is pressed, DTC system status OFF! and current ABS system status are displayed.

 goes out; if self-diagnosis has not completed it starts flashing.

Possible DTC system status ON is displayed.

- Release button **1** once the status has changed.

 remains off or continues to flash.

Possible DTC system status ON is displayed.

» The DTC function is switched on.

–without riding modes Pro^{OE}

- Alternatively, switch the ignition off and on again.<

–with riding modes Pro^{OE}

- See the section entitled "Engineering details" for more information on traction control (DTC):

» How does traction control work? (➡ 158)<

ELECTRONIC SUSPENSION ADJUSTMENT (D-ESA)

Dynamic ESA possible settings

–with Dynamic ESA^{OE}

The electronic chassis and suspension setting Dynamic ESA is able to adjust your motorcycle automatically to the load. If the spring preload is set to *Auto*, the rider does not have to change the load settings.

See the "Engineering details" section for more information on Dynamic ESA (▮▮▮ 160).

Available damping modes

- For on-road mode: Road and Dynamic
- For off-road mode: Enduro

Available load settings

- Fixed set minimum spring preload: Min
- Activated riding position equaliser with automatic adjustment of the spring preload: Auto
- Fixed set maximum spring preload: Max

 BMW Motorrad recommends the *Auto* chassis and suspension setting.

Viewing suspension settings

- with Dynamic ESA^{OE}
- Switch on the ignition (▮▮▮ 60).



- Short-press button **1** to view the current setting.

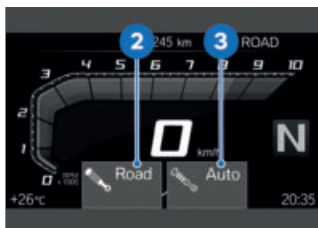

Immediately after button **1** is pressed, the settings for damping **2** and spring preload **3** are displayed.

» The setting shows briefly, then disappears automatically.

Adjusting suspension damping

- with Dynamic ESA^{OE}
- Switch on the ignition (▮▮▮ 60).

76 OPERATION



- Short-press button **1** to view the current setting.

To adjust damping:

- Repeatedly short-press button **1** until the setting you want to use is displayed.

 You can adjust the damping characteristic while the motorcycle is on the move.



Selection arrow **4** is displayed.

» The selection arrow **4** disappears after the status is changed.

The following settings are available:

- Road: damping for comfortable on-road riding

- Dynamic: damping for dynamic on-road riding
- Enduro: damping for off-road riding. Available only in the ENDURO or the ENDURO PRO riding mode and cannot be adjusted in either of these riding modes.

The following message is displayed in the selected riding mode if no setting is possible:

In ENDURO riding mode
damp. not adjustable.

Adjusting spring preload



To adjust spring preload:

- Start the engine (▶▶▶ 136).
- Repeatedly long-press button **1** until the setting you want to use is displayed.

 BMW Motorrad recommends the Auto setting. Min can be used for better ground accessibility and Max, for example, for the off-road mode.

 The Min, Auto and Max settings can be chosen only when the vehicle is stationary.

The following message is displayed if no setting is possible: Load adjustment only avail. stopped.



Selection arrow **4** is displayed.

» The selection arrow **4** disappears after the status is changed.

The following settings are available:

- Min: minimum spring preload
- Auto: automatic adjustment of spring preload
- Max: maximum spring preload

» The settings for damping and spring preload shown on the display are automatically accepted if you allow a certain length of time to pass without pressing button **1**.

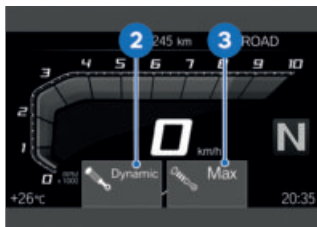

The new settings for damping **2** and spring preload **3** appear briefly on the display.

- If the temperature is very low, take the weight off the motorcycle before increasing spring preload; if applicable, have your passenger dismount.
- » The chassis and suspension settings disappear once adjustment is complete.
- » In Auto loading mode, the spring preload is adjusted only once the motorcycle is driven off.

RIDING MODE

Using riding modes

BMW Motorrad has developed operational scenarios for your motorcycle from which you can select the scenario suitable for your situation:

78 OPERATION

Standard

- ECO: range-optimised riding.
- RAIN: riding on a rain-wet road surface.
- ROAD: riding on a dry road surface.

-with riding modes Pro^{OE}

with Pro riding modes

- ENDURO: riding off-road with road tyres.
- DYNAMIC: dynamic riding on a dry road surface.
- ENDURO PRO: riding off-road with cleated off-road tyres with provision for the rider's custom settings.
- DYNAMIC PRO: dynamic riding on a dry road surface with provision for the rider's custom settings.

The optimum interplay of engine characteristic, DTC, ABS and MSR is provided for each of these scenarios.

-with Dynamic ESA^{OE}

The chassis and suspension adjustment can also be adjusted in the scenario selected.

For more information on the riding modes, see the section entitled "Engineering details" (▣▶ 161).

Riding-mode preselection

You can preselect riding modes so that you can switch from one to the other while on the move. Between two and four riding modes can be preselected at any given time.

Factory setting:

ECO, RAIN and ROAD

-with riding modes Pro

Additionally: ENDURO

Preselecting riding mode

- Switch on the ignition (▣▶ 60).
- Navigate to Settings, Vehicle settings, Driving mode preselection.
- Select riding modes.

The following ride modes can be selected:

- ECO: for range-optimised riding.
- RAIN: for riding on rain-wet roads.
- ROAD: for riding on dry roads.

-with riding modes Pro^{OE}

The following riding modes are additionally available for selection:

- DYNAMIC: for dynamic riding on dry roads.
- ENDURO: for off-roading with road tyres.◀
- DYNAMIC PRO: for dynamic riding on dry roads with pro-

vision for the rider's custom settings.

- ENDURO PRO: for off-roading with cleated off-road tyres with provision for the rider's custom settings.

Selecting riding mode

- Switch on the ignition (▶▶▶ 60).
- Preselect a riding mode (▶▶▶ 78).



- Press button **1**.

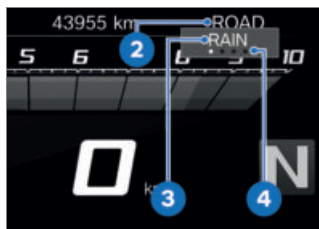

The riding mode currently active **2** is sent to the back and the first selectable riding mode **3** is displayed. The guide **4** indicates how many riding modes are available.



⚠ ATTENTION

Activation of the off-road mode (ENDURO and ENDURO PRO) for on-road riding

Risk of crash due to lack of stability when the vehicle brakes in the control range of ABS or accelerates in that of. DTC

- Activate off-road mode (ENDURO and ENDURO PRO) only for riding off-road.
- Repeatedly press button **1** until the riding mode you want is displayed.

 With the factory setting, the ABS control for the rear wheel is deactivated when the ENDURO PRO riding mode is active.

» With the motorcycle at a standstill, the selected

- The settings can be reset to the factory settings:
- Resetting riding mode settings (➡ 81).

Setting up Dynamic Pro

- Select the PRO riding mode (➡ 80).
- Set up the systems in the same way as with ENDURO PRO riding mode.

Resetting riding mode settings

- Select the PRO riding mode (➡ 80).
- Select **Reset** and confirm.
 - » The following factory settings apply for ENDURO PRO RIDING MODE:
 - ENGINE: Road
 - DTC: Enduro Pro
 - ABS: Enduro Pro
 - » The following factory settings apply for DYNAMIC PRO RIDING MODE:
 - ENGINE: Dynamic
 - DTC: Dyna Pro
 - ABS: Dynamic

ADAPTIVE CRUISE CONTROL

- with cruise control^{OE}

Display when adjusting settings (Speed Limit Info not active)



The symbol **1** for adaptive cruise control is displayed in the Pure Ride view and in the top status line.

Display when adjusting settings (Speed Limit Info active)



The symbol **1** for adaptive cruise control is displayed in the Pure Ride view and in the top status line.

82 OPERATION

Switching on adaptive cruise control

Requirement

Adaptive cruise control is not available until after you exit the ENDURO or the ENDURO PRO riding mode.

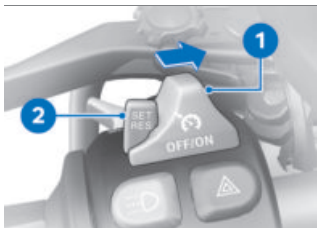

- Slide switch **1** to the right.
» Button **2** is operational.

Setting road speed



- Briefly push button **1** forward.



Adjustment range for adaptive cruise control (gear-dependent)

20...210 km/h



Indicator light for cruise control lights up.

- » The motorcycle maintains your current cruising speed and the setting is saved.

Accelerating



- Briefly push button **1** forward.
» Speed is increased by approx. 1 km/h each time you push the button.
- Push button **1** forward and hold it in this position.
» The motorcycle accelerates smoothly.
» The current speed is maintained and saved if button **1** is not pushed again.

Decelerating



- Briefly push button **1** back.
 - » Speed is reduced by 1 km/h each time you push the button.
- Push button **1** back and hold it in this position.
 - » The motorcycle decelerates smoothly.
 - » The current speed is maintained and saved if button **1** is not pushed again.

Deactivating adaptive cruise control

- Brake, pull the clutch lever or turn the throttle grip (close the throttle by turning the grip back past the idle position) to deactivate adaptive cruise control.

 For safety reasons, adaptive cruise control is automatically deactivated when Gear Shift Assistant Pro downshifts.

 For safety reasons, adaptive cruise control is automatically deactivated when an DTC intervention occurs.

» Indicator light for adaptive cruise control goes out.

Resuming former cruising speed



- Briefly push button **1** back to return to the speed saved beforehand.

 Opening the throttle does not deactivate cruise control. When the twistgrip is released the motorcycle decelerates only to the speed saved in memory, even if the rider intended slowing to a lower speed.

 Indicator light for cruise control lights up.

84 OPERATION

Switching off adaptive cruise control

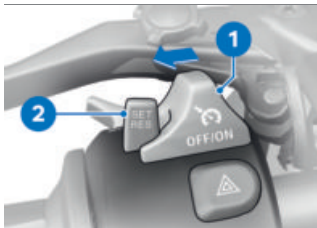

- Slide switch **1** to the left.
» The system is deactivated.
» Button **2** is disabled.

HILL START CONTROL

Reading

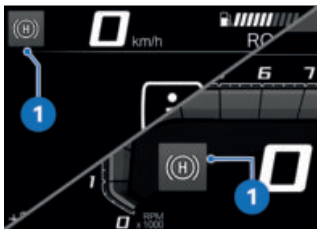

Symbol **1** for Hill Start Control is displayed in the Pure Ride view and in the top status line.

Operating Hill Start Control Requirement

Vehicle stationary and upright, engine running.

ATTENTION

Failure of Hill Start Control

Risk of accident

- Apply the brakes manually to hold the vehicle.

 Hill Start Control is purely a comfort system to facilitate holding the machine and pulling way on uphill gradients and should not be confused with a parking brake.

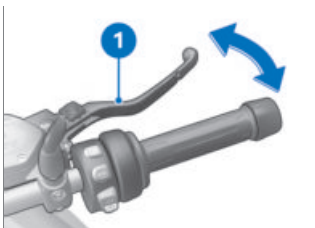

- Apply firm pressure to handbrake lever **1** or to the footbrake lever and then quickly release the lever.

 Green holding symbol is displayed.

- » Hill Start Control is activated.
- To switch off Hill Start Control, operate handbrake lever **1** or the footbrake lever again.

(H) The holding symbol disappears.

- Alternatively, ride off in 1st or 2nd gear.

(i) In order for the motor-cycle to pull away from rest with Hill Start Control, the throttle grip has to be turned to open the throttle for pullaway.

(H) Once the brake has been fully released, the holding symbol disappears.

» Hill Start Control is deactivated.

- See the section entitled "Engineering details" for more information on Hill Start Control:

» Hill Start Control function (169)

Switching Hill Start Control on or off

- Switch on the ignition (60).
- Call up the Settings, Vehicle settings menu.
- Switch Hill Start Control on or off.

Operating Hill Start Control Pro

—with riding modes Pro^{OE}

Requirement

Vehicle stationary and upright, engine running.

! ATTENTION

Failure of Hill Start Control

Risk of accident

- Apply the brakes manually to hold the vehicle.

(i) The drive-off assistant Hill Start Control Pro is only a comfort system to enable easier riding off on gradients and should not be confused with an electromechanical holding brake.

(i) The Hill Start Control Pro drive-off assistant should not be used on inclines of over 40 %.

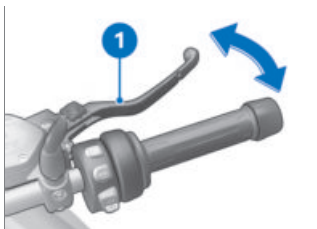

- Apply firm pressure to hand-brake lever **1** or to the foot-brake lever and then quickly release the lever.
- Alternatively, apply the brake for about one second beyond

86 OPERATION

the vehicle reaching a standstill on an incline of at least 3 %.

 Green holding symbol is displayed.

» Hill Start Control Pro is activated.

- To switch off the Hill Start Control Pro, operate the brake lever **1** or footbrake lever again.

 If Hill Start Control Pro has been deactivated by means of the handbrake lever, automatic Hill Start Control is deactivated for the next 4 m.

 The holding symbol disappears.

- Alternatively, ride off in 1st or 2nd gear.

 In order for the motorcycle to pull away from rest with Hill Start Control Pro, the throttle grip has to be turned to open the throttle for pullaway.

 Once the brake has been fully released, the holding symbol disappears.

» Hill Start Control Pro is deactivated.

- See the "Engineering details" section for more information on Hill Start Control Pro:

» Hill Start Control function
( 169)

Setting up Hill Start Control Pro

—with riding modes Pro^{OE}

- Switch on the ignition ( 60).
- Navigate to **Settings**, **Vehicle settings**.
- Select **HSC Pro**.
- To switch off Hill Start Control Pro, select **Off**.
- » Hill Start Control Pro is deactivated.
- To switch on manual Hill Start Control Pro, select **Manual**.
- » Hill Start Control Pro can be activated by forcefully operating the handbrake or footbrake lever.
- To switch on automatic Hill Start Control Pro, select **Auto**.
- » Hill Start Control Pro can be activated by forcefully operating the handbrake or footbrake lever.
- » If the brake is actuated for approximately one second after the vehicle has come to a standstill and the motorcycle is on a gradient of at least 3%, Hill Start Control Pro is automatically activated.
- » The selected setting remains stored even after the ignition is switched off.

ANTI-THEFT ALARM (DWA)

Activation

–with anti-theft alarm (DWA)^{OE}

- Switch on the ignition (▣▣▣ 60).
- Customising anti-theft alarm settings (▣▣▣ 89).
- Switch off the ignition.

» If the alarm system is activated, then the alarm system will be automatically activated when the ignition is switched off.

» Activation takes approximately 30 seconds to complete.

» Turn indicators flash twice.

» Confirmation tone sounds twice (if programmed).

» Anti-theft alarm is active.

–with Keyless Ride^{OE}

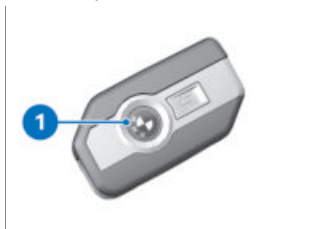

- Switch off the ignition.
- Press button **1** on the radio-operated key twice.
 - » Activation takes approximately 30 seconds to complete.
 - » Turn indicators flash twice.
 - » Confirmation tone sounds twice (if programmed).

» Anti-theft alarm is active.

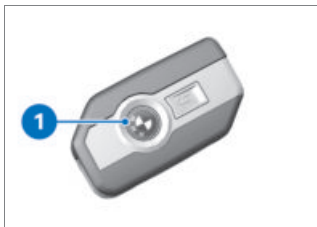

- To deactivate the motion sensor (for example if you are about to transport the motorcycle on a train and the swaying movement of the moving train could trip the alarm), press button **1** on the radio-operated key again during the activation phase.

» Turn indicators flash three times.

» Confirmation tone sounds three times (if programmed).

» Motion sensor has been deactivated.<

Alarm signal

–with anti-theft alarm (DWA)^{OE}

A DWA alarm can be triggered by:

- Motion sensor
- Switch-on attempt with an unauthorised vehicle key.
- Disconnection of the DWA anti-theft alarm from the motorcycle's battery (DWA internal battery in the anti-theft

88 OPERATION

alarm provides power - alarm tone only, the turn indicators do not flash)

All functions are sustained even if the internal battery of the DWA anti-theft alarm system is flat; the only difference is that an alarm cannot be triggered if the system is disconnected from the motorcycle's battery.

An alarm lasts for approximately 26 seconds. While an alarm is in progress an alarm tone sounds and the turn indicators flash. The type of alarm tone can be set by an authorised BMW Motorrad retailer.

—with Keyless Ride^{OE}



The activated alarm can be aborted at any time by pressing the **1** button on the radio-operated key, without deactivating the anti-theft alarm.

If an alarm was triggered while the motorcycle was unattended, the rider is notified accordingly by an alarm tone sounding once when the ignition is switched on. The DWA LED then indicates the reason for the alarm for one minute.

Light signals issued by the DWA LED:

- Flashes 1x: motion sensor 1
- Flashes 2x: motion sensor 2
- Flashes 3x: ignition switched on with unauthorised ignition key
- Flashes 4x: disconnection of the anti-theft alarm from the motorcycle's battery
- Flashes 5x: motion sensor 3

Deactivation

—with anti-theft alarm (DWA)^{OE}

- Kill switch in operating position (run).
- Switch on the ignition.
 - » Turn indicators flash once.
 - » Confirmation tone sounds once (if programmed).
 - » DWA has been switched off.

–with Keyless Ride^{OE}

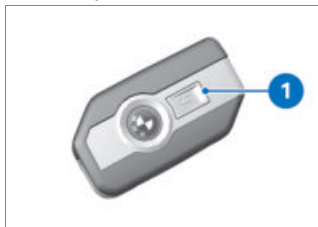

- Press button **1** on the radio-operated key once.

 The alarm function is re-activated after 30 seconds if "activation after ignition off" has been selected if the alarm function is deactivated using the radio-operated key and the ignition is not then switched on.

- » Turn indicators flash once.
- » Confirmation tone sounds once (if programmed).
- » DWA has been switched off.<

Customising anti-theft alarm settings

- Switch on the ignition (▣▣▣ 60).
- Call up the Settings, Vehicle settings, Alarm system menu.
- » The following settings are available:
 - Adapt Warning signal
 - Switch Tilt sensor on or off

- Switch Arming tone on or off
- Switch Arm automatically on or off
- with anti-theft alarm (DWA)^{OE}
 - » Possible settings (▣▣▣ 89)<

Possible settings

- with anti-theft alarm (DWA)^{OE}

Warning signal: set the increasing and decreasing or intermittent alarm tone.

Tilt sensor: activate inclination sensor to monitor the inclination of the vehicle. The DWA responds, for example, to wheel theft or being towed away.

 Deactivate the tilt sensor when transporting the vehicle in order to prevent the DWA from tripping.

Arming tone: confirmation alarm tone after having activated/deactivated the DWA in addition to flashing turn indicators.

Arm automatically: automatic activation of the alarm function when switching off the ignition.

90 OPERATION

TYRE PRESSURE CONTROL (RDC)

- with riding modes Pro^{OE}
- with tyre pressure control (RDC)^{OE}

Switching specified-pressure warning on or off

- The system can be set to issue a specified-pressure warning if tyre pressure drops to the defined minimum.
- Navigate to *Settings*, *Vehicle settings*, *RDC*.
- Switch *Target pressure warn.* on or off.

HEATING

Operating heated handlebar grips

- with heated grips^{OE}
- without seat heating^{OE}

 The heating in the heated handlebar grips can be activated only when the engine is running.

 The increase in power consumption caused by having the heated handlebar grips switched on can drain the battery if you are riding at low engine speeds. If the charge level is low, the heated handlebar grips are switched off to ensure the battery's starting capability.

- Start the engine (➔ 136).

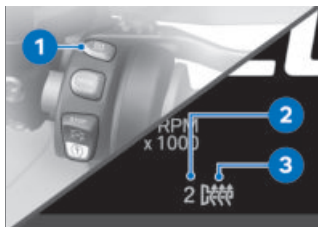

- Repeatedly press button **1** until the desired heating level **2** appears in front of the heated grip symbol **3**.

The handlebar grips have two-stage heating.



Low heating power



High heating power

- » The high stage is for heating the grips quickly: it is advisable to switch back to stage 1 as soon as the grips are warm.
- » The selected heating stage will be saved if you allow a certain length of time to pass without making further changes.
- To switch off the heated grips, repeatedly press button **1** until the heated grip **3** is hidden.

Operating heating

- with heated grips^{OE}
- with seat heating^{OE}

 The heating in the heated handlebar grips and the seat heating can be activated only when the engine is running.

- Start the engine (➡ 136).

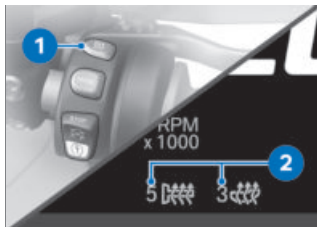

- Press button **1**.
 - » HEATING menu opens.
- Select Grip heating or Seat heating.
- Select the desired heating stage and confirm your choice.
 - » The selected heating stage appears on the left beside heating symbol **2**.
- Press button **1** to close the HEATING menu.
- To switch the heating off, or on again with the heating stage selected beforehand, long-press button **1**.

 The selected heating-stage settings are retained in memory when the ignition is switched off.

Operating rear-seat heating

- with heated grips^{OE}
- with seat heating^{OE}

- Start the engine.

 Seat heating can be activated only when the engine is running.



- Set switch **1** to the desired heating stage.

TFT DISPLAY

05

GENERAL INSTRUCTIONS	94
PRINCIPLE	95
PURE RIDE VIEW	101
GENERAL SETTINGS	102
BLUETOOTH	104
MY VEHICLE	107
NAVIGATION	110
MEDIA	112
PHONE	112
DISPLAY SOFTWARE VERSION	113
DISPLAY LICENCE INFORMATION	113

GENERAL INSTRUCTIONS

TFT display



WARNING

Using a smartphone during the journey or while the engine is running

Risk of accident

- Always observe the relevant road traffic regulations.
- Do not use the smartphone during the journey (apart from applications that do not require operation, e.g. making telephone calls with the hands-free system).



WARNING

Distraction from the road and loss of control

Operating the integrated information system and communication devices while driving results in a risk of accident

- Operate those systems or devices only when the traffic situation allows for it.
- If necessary, stop and operate the systems or devices when stationary.

Connectivity functions

Connectivity functions include media, telephony and navigation. Connectivity functions can be used if the TFT display is connected to a mobile end device and a helmet (104). For more information on the Connectivity functions go to bmw-motorrad.com/connectivity



If the fuel tank is between the mobile device and the TFT display, the Bluetooth connection may be restricted. BMW Motorrad recommends storing the device above the fuel tank (e.g. in your jacket pocket).



Depending on the mobile device, the scope of the Connectivity functions may be restricted.

BMW Motorrad Connected App

The BMW Motorrad Connected App contains usage and vehicle information. For some functions, such as navigation, the app must be installed on the mobile end device and connected to the TFT display. The app is used to start route guidance and adjust the navigation.

 On some mobile devices, e.g. those with iOS operating systems, the BMW Motorrad Connected App must be opened before use.

Actuality

The TFT display may be updated after the publication date. Because of this, your motorcycle may differ from the information supplied in the Rider's Manual. For up-to-date information go to bmw-motorrad.com

PRINCIPLE

Controls

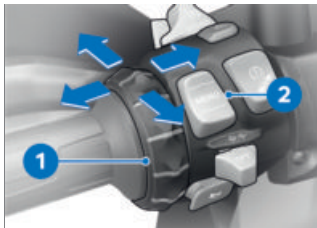

All contents of the display are operated using the multi-controller **1** and the MENU **2** rocker button. Depending on the context, the following functions are possible.

Multi-controller functions

Turn the multi-controller upwards:

- Move the cursor upwards in lists.
- Adjust settings.
- Increase volume.

Turn the multi-controller downwards:

- Move the cursor downwards in lists.
- Adjust settings.
- Decrease volume.

Tilt the multi-controller to the left:

- Activate the function in accordance with the operation feedback.
- Activate the function to the left or back.
- Go back to the Menu view after making the settings.
- In the Menu view: change up one level.
- In the My Vehicle menu: advance one menu screen.

Tilt the multi-controller to the right:

- Activate the function in accordance with the operation feedback.
- Confirm selection.
- Confirm settings.
- Advance a menu step.
- Scroll to the right in lists.

96 TFT DISPLAY

–In the My Vehicle menu: advance one menu screen.

MENU rocker button functions

 Instructions given by the navigation system are displayed in a dialogue box if the Navigation menu has not been called up. Operation of the MENU rocker button is temporarily restricted.

Short-press the top section of the MENU button:

- In the Menu view: change up one level.
- In Pure Ride view: change the display for driver info status line.

Long-press the top section of the MENU button:

- In Menu view: call up Pure Ride view.
- In Pure Ride view: change operating focus to the Navigator.

Short-press the bottom section of the MENU button:

- Change down a level.
- No function if the lowest hierarchical level has been reached.

Long-press the bottom section of the MENU button:

- Change back to the last menu after a previous menu change effected by long-pressing the

top section of the MENU button.

Operating instructions in the main menu

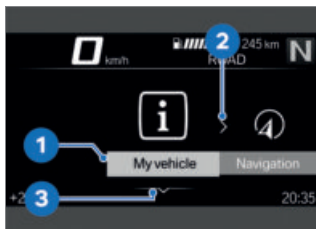

Operating instructions show whether interactions are possible, and which ones.

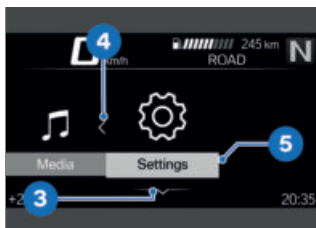

Meaning of the operating instructions:

- Operating instruction 1: the left end has been reached.
- Operating instruction 2: it is possible to scroll to the right.
- Operating instruction 3: it is possible to scroll down.
- Operating instruction 4: it is possible to scroll to the left.

–Operating instruction **5**: the right end has been reached.

Operating instructions in submenus

In addition to the operating instructions in the main menu, there are further operating instructions in submenus.

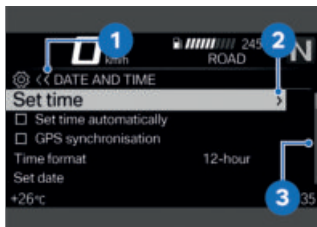

Meaning of the operating instructions:

- Operating instruction **1**: the current display is in a hierarchical menu. One symbol represents one submenu level. Two symbols indicate two or more submenu levels. The colour of the symbol changes, depending on whether you can return to a higher level.
- Operating instruction **2**: one more submenu level can be accessed.
- Operating instruction **3**: there are more entries than can be displayed.

Display Pure Ride view

- Long-press the top section of the MENU rocker button.

Switching functions on and off



Some menu items have a check box in front of them. The check box shows whether the function is on or off. Action symbols after the menu items show what will be switched by tilting the multi-controller briefly to the right.

Examples for switching on and off:

- Symbol **1** shows that the function is switched on.
- Symbol **2** shows that the function is switched off.
- Symbol **3** shows that the function can be switched off.
- Symbol **4** shows that the function can be switched on.

98 TFT DISPLAY

Calling up menu

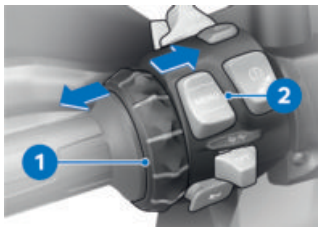

- Display Pure Ride view (▣▣▣▣ 97).
- Briefly push button **2** down. The following menus can be called up:
 - My vehicle
 - Navigation
 - Media
 - Telephone
 - Settings
- Repeatedly press the multi-controller **1** briefly to the right until the desired menu item is highlighted.
- Briefly push button **2** down.

 The Settings menu can only be called up when the vehicle is stationary.

Move the cursor in lists

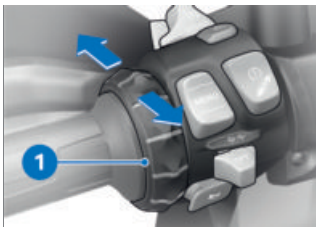

- Call up the menu (▣▣▣▣ 98).
- To move the cursor down in lists, turn the multi-controller **1** down until the desired entry is highlighted.
- To move the cursor up in lists, turn the multi-controller **1** up until the desired entry is highlighted.

Confirming selection

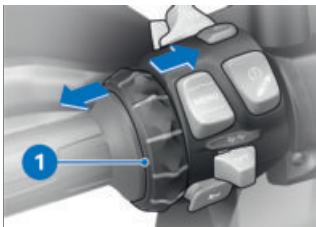

- Select the desired entry.
- Briefly press the multi-controller **1** to the right.

Call up the last menu used

- In Pure Ride view: press and hold the MENU rocker button.
- » The last menu used is called up. The last entry highlighted is selected.

Change of operating focus

–with preparation for navigation system^{OE}

If the Navigator is connected, it is possible to switch between operation of the Navigator and the TFT display.

Changing operating focus

–with preparation for navigation system^{OE}

- Secure the navigation device (▮▮▮▮▶ 220).
- Display Pure Ride view (▮▮▮▮▶ 97).
- Long-press the top section of the MENU rocker button.
- » Operating focus switches to the Navigator or the TFT display, as applicable. The active device is highlighted on the left in the top status line. Operator actions affect the currently active device until the operating focus is changed again.
- » Operating navigation system (▮▮▮▮▶ 222)

System status displays

The system status is displayed in the lower area of the menu if a function is switched on or off.



Example of what the system statuses mean:

–System status 1: DTC function is switched on.

Changing display for driver info. status line

Requirement

The vehicle is at a standstill. The Pure Ride view is displayed.

- Switch on the ignition (▮▮▮▮▶ 60).
- » All necessary information from the on-board computer for operation on public roads (e.g. TRIP 1) and trip computer (e.g. TRIP 2) are available in the TFT display. The information can be displayed in the top status line.

100 TFT DISPLAY

–with tyre pressure control (RDC)^{OE}

» Information from the tyre pressure control can also be displayed.<

- Select content of the rider info. status line (☛ 100).





- Long-press button 1 to obtain the Pure Ride view.
- Briefly press button 1 to select the value in the top status line 2.

The following values can be displayed:

–Total distance Total

 Current distance 1

 Current distance 2

 Consumption 1 (Average)

 Consumption 2 (Average)

 Riding time 1

 Riding time 2

 Break 1

 Break 2

 Speed 1 (Average)

 Speed 2 (Average)

 Tyre pressure

 Range

 Fuel tank level

Select content of the rider info. status line

- Call up the Settings, Display, Status line content menu.
- Switch on the desired displays.
 - » It is possible to switch between the selected displays in the rider info. status line. If no displays are selected, only the range will be displayed.

Adjust settings

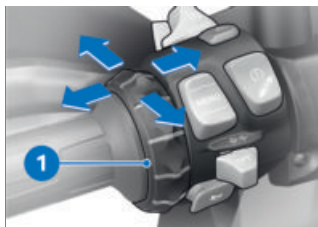

- Select and confirm the desired settings menu.
 - Turn the multi-controller **1** downwards until the desired setting is highlighted.
 - If there are operating instructions, tilt the multi-controller **1** to the right.
 - If there are no operating instructions, tilt the multi-controller **1** to the left.
- » The setting is saved.

Switching Speed Limit Info on or off

Requirement

Vehicle is connected to a compatible mobile device. The BMW Motorrad Connected app is installed on the mobile device.

- **Speed Limit Info** shows the maximum speed permitted at the time, if this information is made available by the publisher of the map material in the navigation system.

- Navigate to **Settings, Display.**
- **Switch Speed Limit Info on or off.**

PURE RIDE VIEW

Rev. counter

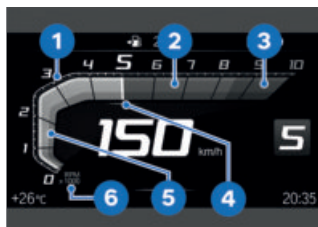

- 1 Scale
- 2 Low engine speed range
- 3 Upper/red engine speed range
- 4 Needle
- 5 Secondary indicator
- 6 Unit for engine speed display:
1000 revolutions per minute

 The red engine speed range changes depending on the coolant temperature: The colder the engine, the lower the engine speed at which the red engine speed range starts. The warmer the engine, the higher the speed at which the red engine speed range starts.

102 TFT DISPLAY

When operating temperature is reached, the display of the red engine speed range no longer changes.

Range

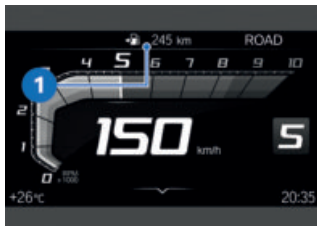

The range readout **1** indicates how far you can ride with the fuel remaining in the tank. This distance is calculated on the basis of average consumption and the quantity of fuel on board.

- When the motorcycle is propped on its side stand the slight angle of inclination means that the sensor cannot register the fuel level correctly. This is the reason why the range is recalculated only when the side stand is in the retracted position.
- The range is shown together with a warning once the fuel reserve has been reached.
- After a refuelling stop, range is recalculated if the amount

- of fuel in the tank is greater than the reserve quantity.
- The calculated range is only an approximate figure.

Recommendation to upshift



The recommendation to upshift in the Pure Ride view **2** or in the status line **1** indicates the best time to upshift economically.

GENERAL SETTINGS

Adjusting volume

- Connect rider's and passenger's helmet (▮▮▮▮▶ 106).
- Increase volume: turn the multi-controller upwards.
- Decrease volume: turn the multi-controller downwards.
- Mute: turn the multi-controller all the way down.

Setting the date

- Switch on the ignition (▮▮▮▮▶ 60).
- Navigate to Settings, System settings, Date and time, Set date.
- Set Day, Month and Year.

- Confirm setting.

Set date format

- Navigate to Settings, System settings, Date and time, Date format.
- Select the desired setting.
- Confirm setting.

Setting clock

- Switch on the ignition (▣▣▣ 60).
- Navigate to Settings, System settings, Date and time, Set time.
- Set Hour and Minute.

Setting time format

- Navigate to Settings, System settings, Date and time, Time format.
- Select the desired setting.
- Confirm setting.

Switching GPS synchronisation on or off

–with preparation for navigation system^{OE}

- Navigate to Settings, System settings, Date and time.
- Switch GPS synchronisation on or off.
- » If the corresponding option in the Navigator is activated, clock time is taken from the Navigator.
- » Special functions (▣▣▣ 225)

Setting units of measurement

- Navigate to Settings, System settings, Units.
- The following units of measurement can be set:
- Distance covered
 - Pressure
 - Temperature
 - Speed
 - Consumption

Setting the language

- Call up the Settings, System settings, Language menu.
- The following languages can be set:
- Chinese
 - German
 - English
 - Spanish
 - French
 - Italian
 - Dutch
 - Portuguese
 - Russian
 - Ukrainian
 - Polish
 - Turkish
 - Korean
 - Thai
 - Japanese

Adjusting brightness

- Navigate to Settings, Display, Brightness.
- Adjust display brightness.
- » When ambient brightness drops below a defined

104 TFT DISPLAY

threshold, the display is dimmed to the brightness set here.

Resetting all settings

- All the settings in the `Settings` menu can be reset to the factory settings.
- Call up the `Settings` menu.
- Select `Reset all` and confirm.

The settings in the following menus are reset:

- Vehicle settings
- System settings
- Connections
- Display
- Information

» Existing Bluetooth connections are not deleted.

BLUETOOTH

Short-range wireless technology

The Bluetooth function might not be available in certain countries.

Bluetooth is a short-range wireless technology. Bluetooth devices are short-range devices transmitting on the license-free ISM band (Industrial, Scientific, Medical) between 2.402 GHz and 2.480 GHz. They can be operated anywhere in the

world without a licence being required.

Although Bluetooth is designed to establish and sustain robust connections over short distances, as with every other wireless technology disruptions are possible. Interference can affect connections or connections can sometimes fail. Particularly when multiple devices operate in a Bluetooth network, with wireless technology of this nature it is not possible to ensure fault-free communications in every situation.

Possible sources of interference:

- interference zones due to transmission masts and similar.
- devices with non-compliant Bluetooth implementations.
- proximity of other Bluetooth-compatible devices.

Pairing

Two Bluetooth devices must detect each other before they can create a connection with each other. This process of mutual recognition is known as pairing. When two devices have paired they remember each other, so the pairing pro-

106 TFT DISPLAY

section entitled "Technical data". (▣▣▣▣ 234)

- » Depending on the mobile end device, telephone data is transferred to the vehicle automatically.
- » Telephone data (▣▣▣▣ 113)
- » If the telephone book is not displayed, consult the troubleshooting chart in the section entitled "Technical data". (▣▣▣▣ 235)
- » If the Bluetooth connection is not working as expected, consult the troubleshooting chart in the section entitled "Technical data". (▣▣▣▣ 235)

Connect rider's and passenger's helmet

- Pairing (▣▣▣▣ 105).
- Select Rider's helmet or Passenger helm. and confirm.
- Make the helmet's communication system visible.
- Select PAIR NEW RIDER'S HELMET or PAIR NEW PASSENGER HELMET and confirm. Helmets are searched for.

 The Bluetooth symbol flashes in the bottom status line during pairing.

Helmets found are displayed.

- Select and confirm helmet.

- » The connection is established and the connection status updated.
- » If the connection is not established, consult the troubleshooting chart in the section entitled "Technical data". (▣▣▣▣ 234)
- » If the Bluetooth connection is not working as expected, consult the troubleshooting chart in the section entitled "Technical data". (▣▣▣▣ 235)

Deleting connections

- Call up the Settings, Connections menu.
- Select Delete connections.
- To delete an individual connection, select the connection and confirm.
- To delete all connections, select Delete all connections and confirm.

MY VEHICLE

Start screen

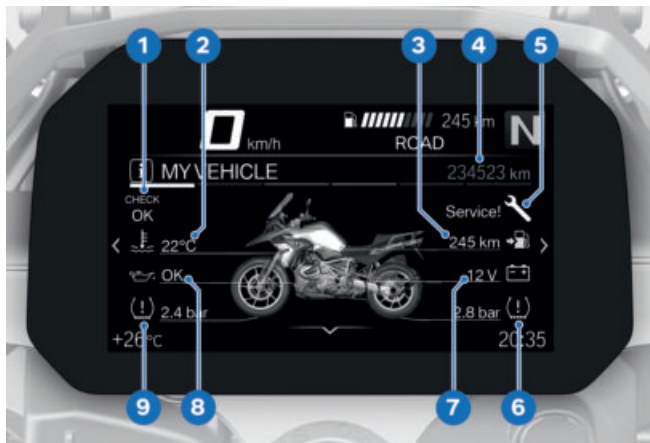

- 1 Check Control display
Mode of presentation
([▮▮▮▮ 31](#))
- 2 Coolant temperature
([▮▮▮▮ 43](#))
- 3 Range ([▮▮▮▮ 102](#))
- 4 Total distance covered
- 5 Service display ([▮▮▮▮ 55](#))
- 6 Tyre pressure, rear
([▮▮▮▮ 46](#))
- 7 On-board voltage
([▮▮▮▮ 200](#))
- 8 Engine oil level ([▮▮▮▮ 43](#))
- 9 Tyre pressure, front
([▮▮▮▮ 46](#))

108 TFT DISPLAY

Operating instructions

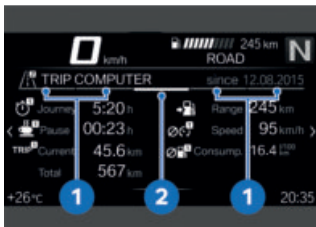

- Operating instruction 1: tabs which show how far to the left or right can be scrolled.
- Operating instruction 2: tab which shows the position of the current menu screen.

Scrolling through menu screens

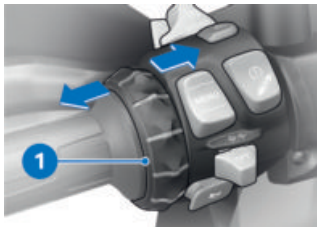

- Call up the My vehicle menu.
- To scroll to the right, short-press Multi-Controller 1 to the right.
- To scroll to the left, short-press Multi-Controller 1 to the left.

The My Vehicle menu contains the following screens:

- MY VEHICLE
- Check Control messages (if any)
- ON-BOARD COMPUTER
- TRIP COMPUTER
- with tyre pressure control (RDC)^{OE}
- TYRE PRESSURE <
- SERVICE REQUIREMENTS
- For more information on tyre pressures and Check Control messages, see the "Displays" section.

 Check Control messages are attached dynamically to the menu screens as additional tabs in the My vehicle menu.

On-board computer and trip computer

The ON-BOARD COMPUTER and TRIP COMPUTER menu screens display vehicle and trip data, such as average values.

Calling up the on-board computer

- Call up the My vehicle menu.
- Scroll to the right until the ON-BOARD COMPUTER menu screen is displayed.

Resetting on-board computer

- Calling up the on-board computer (▣▣▣▣ 108).
- Press down the MENU rocker button.
- Select Reset all values or Reset individual values and confirm.

The following values can be reset:

- Break
- Journey
- Current (TRIP 1)
- Speed
- Consump.

Calling up the trip computer

- Calling up the on-board computer (▣▣▣▣ 108).
- Scroll to the right until the TRIP COMPUTER menu screen is displayed.

Resetting trip computer

- Calling up the trip computer (▣▣▣▣ 109).
 - Press down the MENU rocker button.
 - Select Autom. reset or Reset all values and confirm.
- » If Autom. reset is selected, the journey computer is automatically reset if a minimum of six hours have passed and the date has changed since the ignition was switched off.

Service requirements

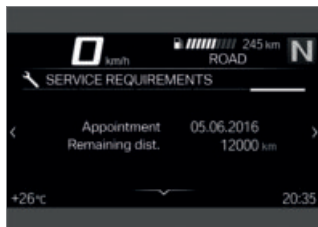

When the next service is due within less than a month or within 1000 km, a white Check Control message is displayed.

NAVIGATION

TFT display



WARNING

Using a smartphone during the journey or while the engine is running

Risk of accident

- Always observe the relevant road traffic regulations.
- Do not use the smartphone during the journey (apart from applications that do not require operation, e.g. making telephone calls with the hands-free system).



WARNING

Distraction from the road and loss of control

Operating the integrated information system and communication devices while driving results in a risk of accident

- Operate those systems or devices only when the traffic situation allows for it.
- If necessary, stop and operate the systems or devices when stationary.

Precondition

The vehicle is connected to a compatible mobile device.

The BMW Motorrad Connected app is installed on the connected mobile device.



On some mobile devices, e.g. those with iOS operating systems, the BMW Motorrad Connected App must be opened before use.

Entering destination address

- Connect mobile end device (➡ 105).
- Call up the BMW Motorrad Connected App and start the route guidance.
- Call up the Navigation menu in the TFT display.
 - » Active route guidance is displayed.
 - » If the active route guidance is not displayed, consult the troubleshooting chart in the section entitled "Technical data". (➡ 235)

Selecting destination from recent destinations

- Call up the Navigation, Recent destinations menu.
- Select and confirm destination.
- Select Start route guidance.

Selecting destination from favourites

- The FAVOURITES menu displays all destinations which have been saved as favourites in the BMW Motorrad Connected app. No new favourites can be added using the TFT display.
- Call up the Navigation, Favourites menu.
- Select and confirm destination.
- Select Start guidance.

Entering special destinations

- Special destinations, such as points of interest, can be displayed on the map.
- Call up the Navigation, POIs menu.

The following locations can be selected:

- At current location
- At destination
- Along the route
- Select where the special destinations should be looked for. e.g. the following special destination can be selected:
 - Filling station
- Select and confirm the special destination.
- Select Start route guidance and confirm.

Setting route criteria

- Call up the Navigation, Route criteria menu. The following criteria can be selected:
 - Route type
 - Avoid
 - Select desired Route type.
 - Switch desired Avoid on or off.
- The number of avoidances activated is displayed in brackets.

Ending route guidance

- Call up the Navigation, Active route guidance menu.
- Select End route guidance and confirm.

Switching spoken instructions on or off

- Connect rider's and passenger's helmet (106).
- The navigation can be read out by a computer voice. For this purpose, Spoken instruction must be switched on.
- Call up the Navigation, Active route guidance menu.
- Switch Spoken instruction on or off.

112 TFT DISPLAY

Repeating last spoken instruction

- Call up the Navigation, Active route guidance menu.
- Select Current instruction and confirm.

MEDIA

Precondition

The vehicle is connected to a compatible mobile device and helmet.

Control music playback

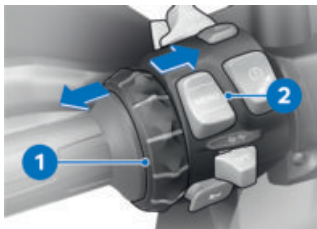

- Call up the Media menu.
-  BMW Motorrad recommends setting the volume on the mobile end device for media and calls to maximum before setting off.
- Adjust the volume (🔊 102).
- Next track: short-tilt Multi-Controller **1** to the right.
- Last track or start of the current track: short-tilt Multi-Controller **1** to the left.

- Fast forward: long-tilt Multi-Controller **1** to the right.
- Rewind: long-tilt Multi-Controller **1** to the left.
- Call up context menu: press bottom part of button **2**.

 Depending on the mobile device, the scope of the Connectivity functions may be restricted.

- » The following functions can be used in the context menu:
- Playback or Pause.
 - Select the Now playing, All artists, All albums or All tracks category for search and playback.
 - Select Playlists.

You can adjust the following settings in the Audio settings submenu:

- Switch Shuffle on or off.
- Select Repeat: Off, One (current track) or All.

PHONE

Precondition

The vehicle is connected to a compatible mobile device and helmet.

SETTING

06

MIRRORS	116
HEADLIGHT	117
WINDSCREEN	118
CLUTCH	118
GEARSHIFT LEVER	119
BRAKES	119
FOOTRESTS	121
HANDLEBARS	122
SEATS	122
SPRING PRELOAD	125
DAMPING	127

116 SETTING

MIRRORS

Adjusting mirrors



- Turn the mirror to the correct position.

Adjusting mirror arm



- Push protective cap **1** over the threaded fastener of the mirror arm up to expose the threaded fastener.
- Slacken nut **2**.
- Turn the mirror arm to the appropriate position.
- Tighten the nut to the specified torque, while holding the mirror arm to ensure that it does not move out of position.

 Mirror (locknut) to adapter

22 Nm (Left-hand thread)

- Push protective cap **1** over the threaded fastener.

Adjusting mirrors

—with Option 719 Milled Part Set Classic^{OE}

or

—with Option 719 Milled Part Set Storm^{OE}



- Turn the mirror **1** to the correct position.

Adjusting mirror arm

—with Option 719 Milled Part Set Classic^{OE}

or

—with Option 719 Milled Part Set Storm^{OE}



A small and a large angle screwdriver is supplied with the vehicle for adjusting the mirror arm.

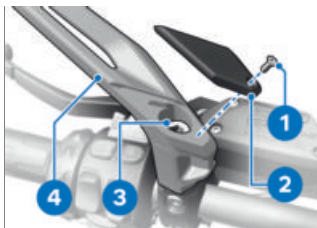

- Remove bolt **1** and cover **2**.
- Loosen adjusting screw **3** and turn the mirror arm **4** to the desired position.
- Tighten adjusting screw **3**, while holding the mirror arm.
- Attach cover **2** and fit bolt **1**.



Mirror on handlebars

25 Nm

–with hand protector^{OE}

25 Nm<

HEADLIGHT

Headlight beam throw and spring preload

Headlight beam throw is generally kept constant when spring preload is adjusted to suit load.

Spring preload adjustment might not suffice only if the motorcycle is very heavily loaded. Under these circumstances, headlight beam throw has to be adjusted to suit

the weight carried by the motorcycle.

 If there are doubts about the correct headlight beam throw, have the setting checked by a specialist workshop, preferably an authorised BMW Motorrad dealer.

Adjusting headlight beam throw

Requirement

When the motorcycle is heavily loaded, spring preload adjustment is not enough to prevent the vehicle's headlight from dazzling oncoming traffic.



- Adjust headlight beam throw by turning adjusting screw **1**.

118 SETTING

WINDSCREEN

Adjusting windscreen

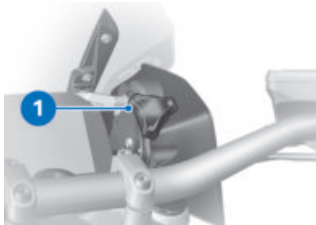

WARNING

Adjusting the windscreen while riding

Risk of falling

- Do not attempt to adjust the windscreen unless the motorcycle is at a standstill.

- Turn adjuster knob **1** clockwise to lower the windscreen.
- Turn adjuster knob **1** counter-clockwise to raise the windscreen.

CLUTCH

Clutch

WARNING

Adjusting the clutch lever while riding

Risk of accident

- Adjust the clutch lever only when the motorcycle is at a standstill.

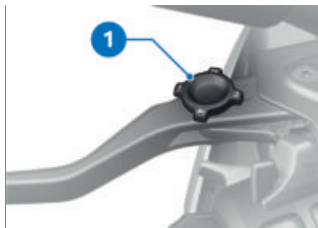

- Turn adjuster knob **1** to the desired position.
-  The adjuster is easier to turn if you push the clutch lever forward.
- » Four settings are possible:
 - Position 1: narrowest span between handlebar grip and clutch lever
 - Position 4: widest span between handlebar grip and clutch lever

–with Option 719 Milled Part Set Classic^{OE}

or

–with Option 719 Milled Part Set Storm^{OE}

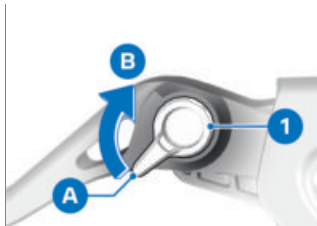

- Turn adjustment lever **1** to the desired position.
 - » Adjustment options:
 - From position **A**: narrowest span between handlebar grip and clutch lever.
 - In 5 steps in direction of position **B** for enlarging the distance between handlebar grip and clutch lever.◀

GEARSHIFT LEVER

–with Option 719 Milled Part Set Classic^{OE}

or

–with Option 719 Milled Part Set Storm^{OE}

Adjusting gearshift lever peg

- Foot clearance and height relative to peg **2** can be adjusted by turning to different positions.

- Remove screw **1**.

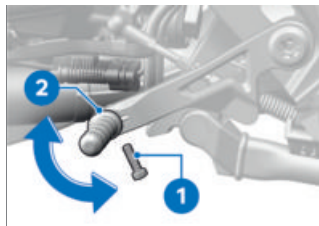

- Clean the threads.
- Turn peg **2** to the desired position.
- Install **new** screw **1**.



Peg to gearshift lever

Thread-locking compound:
micro-encapsulated

10 Nm

BRAKES

Adjusting handbrake lever



WARNING

Adjusting the handbrake lever while riding

Risk of accident

- Do not attempt to adjust the handbrake lever unless the motorcycle is at a standstill.

120 SETTING

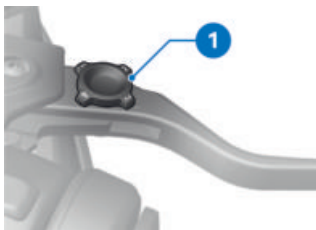

- Turn adjuster knob **1** to the desired position.

 The adjuster is easier to turn if you push the brake lever forward.

» Four settings are possible:

- Position 1: narrowest span between handlebar grip and brake lever
- Position 4: widest span between handlebar grip and brake lever

–with Option 719 Milled Part Set Classic^{OE}

or

–with Option 719 Milled Part Set Storm^{OE}

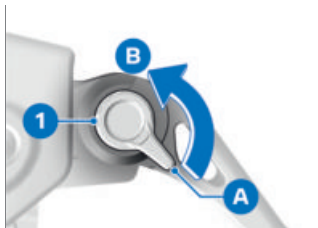

- Turn adjustment lever **1** to the desired position.
 - » Adjustment options:
 - From position **A**: narrowest span between handlebar grip and handbrake lever.
 - In 5 steps toward position **B** to increase the span between handlebar grip and handbrake lever.◁

Adjusting footbrake lever peg

–with Option 719 Milled Part Set Classic^{OE}

or

–with Option 719 Milled Part Set Storm^{OE}

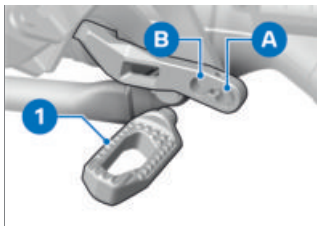

- Foot distance and height to peg **1** can be adjusted by turning through 180° and installation in position **A** or **B**.
- Remove screw **1**.

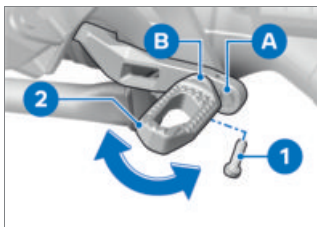

- Clean the threads.
- Install peg **2** in desired position **A** or **B**.
- Turn peg **2** to the desired position.
- Install **new** screw **1**.



Peg to footbrake lever

Thread-locking compound:
micro-encapsulated

10 Nm

FOOTRESTS

–with Option 719 Milled Part Set Classic^{OE}

or

–with Option 719 Milled Part Set Storm^{OE}

Adjusting footrests

- The footrest is adjusted on the right and left in the same way.
- The position of the footrest must be set identically on the right and on the left.

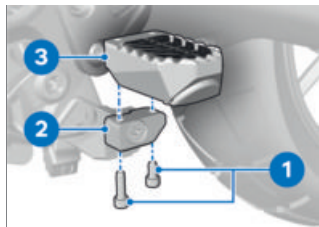

- Remove screws **1**.
- Remove footrest **3** from clamping block **2**.

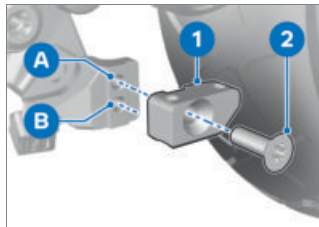

- Remove screw **2**.

122 SETTING

- Remove clamping block 1.

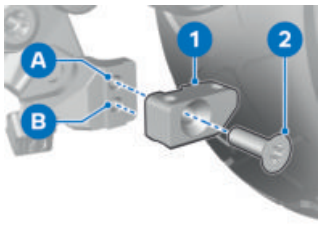

- Install clamping block 1 in required position **A** or **B** and tighten bolt 2.

 Clamping block on footrest hinge

20 Nm

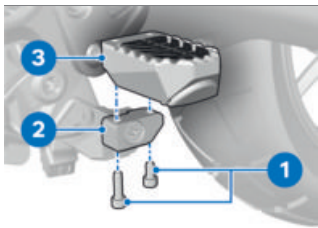

- Position footrest 3 on clamping block 2.
- Install screws 1.

 Footrest on clamping block

10 Nm

- Remove and refit the footrest on the other side in the same way.

HANDLEBARS

Adjustable handlebars

 When adjusting the handlebars, make sure that the mirrors do not come into contact with the windscreen. If necessary, adjust the mirror arm accordingly.

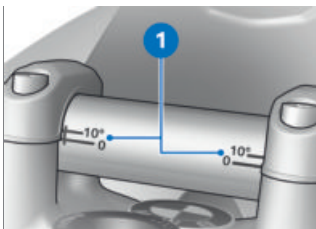

The tilt of the handlebars is adjustable within the range indicated by mark 1.

Have the handlebars adjusted by a specialist workshop, preferably an authorised BMW Motorrad retailer.

SEATS

Removing passenger seat

- Make sure the ground is level and firm and place the motorcycle on its stand.

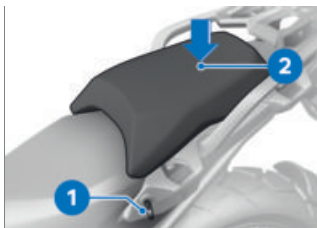

- Turn the ignition key to the right in seat lock **1** and hold it in this position, while pressing down the rear part **2** of the passenger seat.
- Slightly raise the passenger seat at the front and release the ignition key.
- Rear seat position: push the passenger seat forward.
- Front seat position: push the passenger seat back.
- Remove the rear seat and place it, upholstered side down, on a clean surface.

Installing passenger seat



ATTENTION

Damaged components

Damage to sensors, for example, which causes malfunctions

- Do not transport any objects underneath the driver or passenger seat.
- Secure the toolkit.

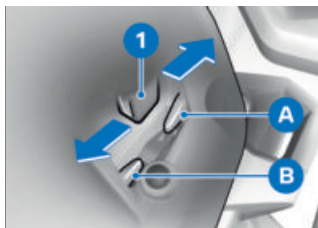

- Bear in mind the position of the rider's seat with regard to the direction for adjustment of the passenger seat.
 - The passenger seat can be set to either of 2 different positions.
- Set passenger seat with both lugs **1** centrally in the mounting.
 - Rear seat position: press passenger seat to the rear **A**.
 - Front seat position: press passenger seat to the front **B**.
- » Lugs **1** of the passenger seat are correctly located.



- Press down firmly on passenger seat **1** at the front.

124 SETTING

» The passenger seat engages with an audible click.

Removing rider's seat

- Remove the passenger seat (▶▶ 122).

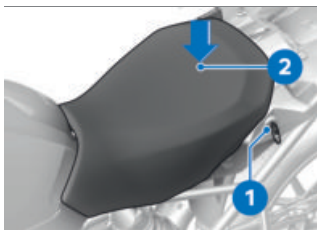

- Turn the ignition key to the left in seat lock **1** and hold it in this position, while pressing down the rear part **2** of the rider's seat.
- Slightly raise the rider's seat at the rear and release the ignition key.
- Remove the rider's seat and place it, upholstered side down, on a clean surface.

Adjusting height and angle of tilt of rider's seat

- Remove the rider's seat (▶▶ 124).

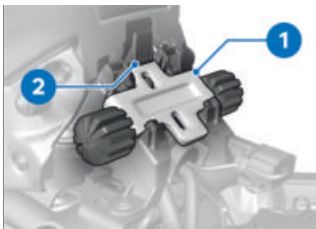

- To remove the front height adjustment **1**, push the locking mechanism **2** forwards and remove the height adjustment in an upwards direction.

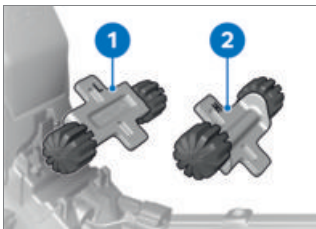

- To adjust the low seat position, install the front height adjustment and align it with **1** (identification L).
- To adjust the high seat position, install the front height adjustment and align it with **2** (identification H).

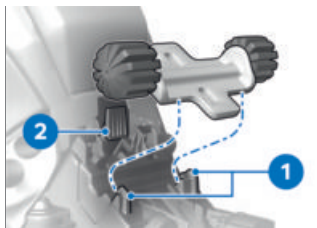

- First push the front height adjustment under the mounting **1** then push it into the locking mechanism **2** until it engages.

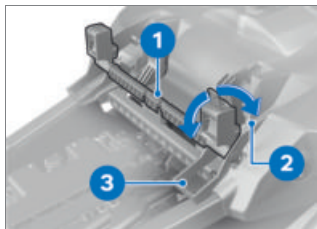

- To adjust the low seat position, swing the rear height adjustment **1** into position **3** (identification L).
- To adjust the high seat position, swing the rear height adjustment **1** into position **2** (identification H).

To change the angle of seat tilt:

- Position front and rear height adjusters differently.

Installing rider's seat

- Remove the passenger seat (→ 122).
- Adjust the height and angle of tilt of the rider's seat (→ 124).



- Engage the rider's seat in mounts **1** on left and right and lower it on to the motorcycle.
- Applying pressure to the rear of the seat, push the rider's seat slightly forward and then press it firmly down until the lock engages.

SPRING PRELOAD

—without Dynamic ESA^{OE}

126 SETTING

Adjustment

It is essential to set the spring preload of the rear suspension to suit the load carried by the motorcycle. Increase the spring preload when the vehicle is heavily loaded and reduce the spring preload accordingly when the vehicle is lightly loaded.

Adjusting spring preload for rear wheel

WARNING

Adjusting spring preload while riding.

Risk of accident

- Do not attempt to adjust spring preload unless the motorcycle is at a standstill.
- Make sure the ground is level and firm and place the motorcycle on its stand.

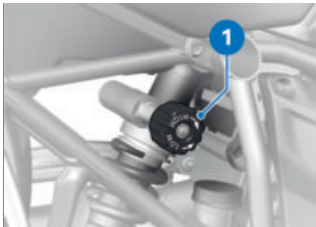

WARNING

Spring preload setting and spring-strut damping setting not matched.

Impaired handling.

- Adjust spring-strut damping to suit spring preload.
- To increase spring preload, turn adjuster knob **1** in the direction indicated by the HIGH arrow.
- To reduce spring preload, turn adjuster knob **1** in the direction indicated by the LOW arrow.



Basic setting of spring preload, rear

Turn the knob as far as it will go in the LOW direction.
(One-up without luggage)



Basic setting of spring preload, rear

Turn the adjuster knob as far as it will go in the LOW direction, then 15 turns in the HIGH direction. (One-up with luggage)

Turn the adjuster knob as far as it will go in the LOW direction, then 30 turns in the HIGH direction. (Two-up with luggage)

DAMPING

—without Dynamic ESA^{OE}

Setting

Damping must be adapted to suit the surface on which the motorcycle is ridden and to suit spring preload.

—An uneven surface requires softer damping than a smooth surface.

—An increase in spring preload requires firmer damping, a reduction in spring preload requires softer damping.

Adjusting damping for rear wheel

- Make sure the ground is level and firm and place the motorcycle on its stand.
- Set the damping from the left-hand vehicle side.

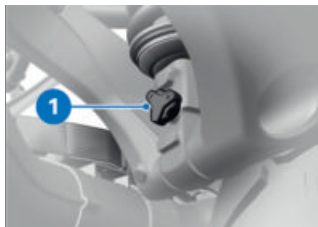

- Turn the adjusting screw **1** clockwise to harden the damping action.
- Turn the adjusting screw **1** anticlockwise to soften the damping action.



Basic setting of rear-suspension damping characteristic

Turn the adjuster knob as far as it will go in the clockwise direction, then back it off 8 clicks in the counter-clockwise direction. (One-up without luggage)

Turn the adjuster knob as far as it will go in the clockwise direction, then back it off 2 clicks in the counter-clockwise direction. (One-up with luggage)

128 SETTING



Basic setting of rear-suspension damping characteristic

Turn the adjuster knob as far as it will go in the clockwise direction, then back it off 2 clicks in the counter-clockwise direction. (Two-up with luggage)

RIDING

07

SAFETY INSTRUCTIONS	132
COMPLY WITH CHECKLIST	135
ALWAYS BEFORE RIDING OFF	135
AT EVERY THIRD REFUELLING STOP	136
STARTING	136
RUNNING IN	138
OFF-ROAD USE	140
SHIFTING GEAR	141
BRAKES	142
PARKING YOUR MOTORCYCLE	144
REFUELLING	145
SECURING MOTORCYCLE FOR TRANSPORTATION	150

SAFETY INSTRUCTIONS

Rider's equipment

Do not ride without the correct clothing! Always wear:

- Helmet
- Motorcycling jacket and trousers
- Gloves
- Boots

This applies even to short journeys, and to every season of the year. Your authorised BMW Motorrad dealer will be glad to advise you on the correct clothing for every purpose.

Restricted angle of heel

-with low-slung^{OE}

A motorcycle with lowered suspension has less ground clearance and cannot corner at angles of heel as extreme as those achievable by a counterpart motorcycle with standard-height suspension.



WARNING

When a motorcycle with lowered suspension is cornering, certain components can come into contact with the surface at a bank angle less than that to which the rider is accustomed.

Risk of falling

- Carefully try out the limits of the motorcycle's bank angle and adapt your style of riding accordingly.

Test your motorcycle's angle of heel in situations that do not involve risk. When riding over kerbs and similar obstacles, bear in mind that your motorcycle's ground clearance is limited.

Lowering the motorcycle's suspension shortens suspension travel (see the section entitled "Technical Data"). Ride comfort might be restricted as a result. Be sure to adjust spring preload accordingly, particularly for riding two-up.

Loading



WARNING

Handling adversely affected by overloading and imbalanced loads

Risk of falling

- Do not exceed the permissible gross weight and be sure to comply with the instructions on loading.
- Adjusting spring preload setting and damping to the total weight.
 - with case^{OA}
- Ensure that the case volumes on the left and right are equal.
- Make sure that the weight is uniformly distributed between right and left.
- Pack heavy items at the bottom and toward the inboard side.
- Note the maximum permissible payload and the speed limit for riding with cases fitted, as stated on the label inside the case (see also the section entitled "Accessories").<
- with topcase^{OA}
- Note the maximum permissible payload and the speed limit for riding with topcase fitted, as stated on

the label inside the case (see also the section entitled "Accessories").<

–with tank bag^{OA}

- Note the maximum permissible payload of the tank rucksack.



Payload of tank rucksack

max 5 kg<

Speed

If you ride at high speed, always bear in mind that various boundary conditions can adversely affect the handling of your motorcycle:

- Settings of the spring-strut and shock-absorber system
- Imbalanced load
- Loose clothing
- Insufficient tyre pressure
- Poor tyre tread
- Etc.

134 RIDING

Maximum speed with knobbly tyres or winter tyres



DANGER

Maximum speed of the motorcycle is higher than the permissible maximum rated speed of the tyres

Risk of accident due to tyre damage at high speed

- Comply with the tyre-specific speed restrictions.

Always bear the maximum permissible speed of the tyres in mind when riding a motorcycle fitted with knobbly tyres or winter tyres.

Affix a label stating the maximum permissible speed to the instrument panel in the rider's field of vision.

Risk of poisoning

Exhaust fumes contain carbon monoxide, which is colourless and odourless but highly toxic.



WARNING

Exhaust gases adversely affecting health

Risk of asphyxiation

- Do not inhale exhaust fumes.
- Do not run the engine in an enclosed space.



WARNING

Inhalation of harmful vapours

Health hazard

- Do not inhale vapours from operating fluid and plastics.
- Use the vehicle only outdoors.

Risk of burn injury



CAUTION

Engine and exhaust system become very hot when the vehicle is in use

Risk of burn injury

- When you park the vehicle make sure that no-one and no objects can come into contact with the hot engine and exhaust system.

Catalytic converter

If misfiring causes unburned fuel to enter the catalytic converter, there is a danger of overheating and damage.

The following guidelines must be observed:

- Do not run the fuel tank dry.
- Do not attempt to start or run the engine with a spark-plug cap disconnected.
- Stop the engine immediately if it misfires.

- Use only unleaded fuel.
- Comply with all specified maintenance intervals.



ATTENTION

Unburned fuel in catalytic converter

Damage to catalytic converter

- Note the points listed for protection of the catalytic converter.

Risk of overheating



ATTENTION

Engine running for prolonged period with vehicle at standstill

Overheating due to insufficient cooling; in extreme cases vehicle fire

- Do not allow the engine to idle unnecessarily.
- Ride away immediately after starting the engine.

Tampering



ATTENTION

Tampering with the motorcycle (e.g. engine management ECU, throttle valves, clutch)

Damage to the affected parts, failure of safety-relevant functions, voiding of warranty

- Do not tamper with the vehicle in any way that could result in tuned performance.

COMPLY WITH CHECKLIST

- At regular intervals, use the checklist below to check your motorcycle.

ALWAYS BEFORE RIDING OFF

- Check operation of the brake system.
- Check operation of the lights and signalling equipment.
- Checking clutch function (▮▮▮▮▶ 185).
- Checking tyre tread depth (▮▮▮▮▶ 188).
- Check the tyre pressures (▮▮▮▮▶ 187).
- Check that cases and luggage are securely held in place.

AT EVERY THIRD REFUELING STOP

- Check the engine oil level (➡ 179).
- Check the brake pad thickness, front brakes (➡ 181).
- Check the brake pad thickness, rear brakes (➡ 182).
- Check the brake-fluid level, front brakes (➡ 183).
- Check the brake-fluid level, rear brakes (➡ 184).
- Check the coolant level (➡ 185).

STARTING

Starting engine

- Switch on the ignition.
 - » Pre-Ride-Check is performed. (➡ 137)
 - » ABS self-diagnosis is in progress. (➡ 137)
 - » DTC self-diagnosis is in progress. (➡ 138)
- Select neutral or, if a gear is engaged, pull the clutch lever.

 You cannot start the motorcycle with the side stand extended and a gear engaged. The engine will switch itself off if you start it with the gearbox in neutral and then engage a gear before retracting the side stand.

- For a cold engine start and low temperatures: pull clutch.

—with M Lightweight battery^{OE}
» Low temperatures can impact on the starting response. Repeated, brief application of load on the battery causes battery temperature to rise, so more battery power is available for starting the engine.◀



- Press the starter button **1**.
 - » The engine starts.
 - » If the engine refuses to start, consult the troubleshooting chart in the section entitled "Technical data". (➡ 234)
- Recharge the battery before you try again to start the engine, or use jump leads and a donor battery to start:
- Charge battery when connected (➡ 200).
 - Jump-starting (➡ 197).
-  The start attempt is automatically interrupted if battery voltage is too low.

Pre-Ride-Check

The instrument cluster runs a test of the instruments and the indicator and warning lights when the ignition is switched on. This test is known as the Pre-Ride-Check. The check is aborted if you start the engine before it completes.

Phase 1

All indicator and warning lights are switched on.

After a longer vehicle standstill period, an animation is displayed when the system starts up.

Phase 2

The 'General' warning light changes from red to yellow.

Phase 3

All the indicator and warning lights switched on in the initial phase are switched off in reverse sequence.

The malfunction indicator lamp (MIL) does not go out until 15 seconds have elapsed.

If one of the indicator and warning lights did not switch on:

- Have the fault rectified as quickly as possible by a specialist workshop, preferably an

authorised BMW Motorrad retailer.

ABS self-diagnosis

BMW Motorrad Integral ABS Pro performs self-diagnosis to ensure its operability. Self-diagnosis starts automatically when you switch on the ignition.

Phase 1

» Test of the diagnosis-compatible system components with the vehicle at a standstill.



flashes.

Phase 2

» Test of the wheel-speed sensors as the vehicle pulls away from rest.



flashes.

ABS self-diagnosis completed

» The ABS indicator and warning light goes out.



ABS self-diagnosis not completed

The ABS function is not available, because self-diagnosis did not complete. (The motorcycle has to reach a defined minimum speed for the wheel speed sensors to be checked: 5 km/h)

138 RIDING

If an indicator showing an ABS fault appears when ABS self-diagnosis completes:

- You can continue to ride. Bear in mind that neither the ABS function nor the integral braking function is available.
- Have the fault rectified as quickly as possible by a specialist workshop, preferably an authorised BMW Motorrad retailer.

DTC self-diagnosis

BMW Motorrad DTC performs self-diagnosis to ensure its operability. Self-diagnosis is performed automatically when you switch on the ignition.

Phase 1

» Test of the diagnosis-compatible system components with the vehicle at a standstill.



DTC indicator light slow-flashes.

Phase 2

» Pullaway test of the diagnosis-compatible system components.



DTC indicator light slow-flashes.

DTC self-diagnosis completed

- » The DTC symbol no longer shows.
- Check all the indicator lights.



DTC self-diagnosis not completed

The DTC function is not available, because self-diagnosis did not complete. (The motorcycle has to reach a defined minimum speed with the engine running for the wheel-speed sensors to be checked: min 5 km/h)

If an indicator showing a DTC fault appears when DTC self-diagnosis completes:

- You can continue to ride. Bear in mind that the DTC function is not available or the functionality might be subject to certain restrictions.
- Have the fault rectified as quickly as possible by a specialist workshop, preferably an authorised BMW Motorrad retailer.

RUNNING IN

Engine

- Until the first running-in check, vary the throttle opening and engine-speed range frequently; avoid riding

at constant engine rpm for prolonged periods.

- Try to do most of your riding during this initial period on twisting, fairly hilly roads.
- Comply with the rpm limits for running in.

 Running-in speeds
<5000 min ⁻¹ (Odometer reading 0...1000 km)
No full load (Odometer reading 0...1000 km)

- Note the mileage after which the running-in check should be carried out.

 Mileage until the running-in check
500...1200 km

Brake pads

New brake pads have to bed down before they can achieve their optimum friction levels. You can compensate for this initial reduction in braking efficiency by exerting greater pressure on the levers.



WARNING

New brake pads

Longer stopping distance, risk of accident

- Apply the brakes in good time.

Tyres

New tyres have a smooth surface. This must be roughened by riding in a restrained manner at various heel angles until the tyres are run in. This running in procedure is essential if the tyres are to achieve maximum grip.



WARNING

New tyres losing grip on wet roads and at extreme bank angles

Risk of accident

- Ride carefully and avoid extremely sharp inclines.

OFF-ROAD USE

For off-roading Rims



ATTENTION

Off-roading more severe than riding on unsurfaced tracks

Damage to standard cast-aluminium rims

- Use the cross-spoked wheels available as optional extras for severe off-roading.

After off-roading

BMW Motorrad recommends checking the following after riding the motorcycle off-road:

Tyre pressure



WARNING

Lower tyre pressure for off-roading in operation on smooth roads

Risk of accident due to impaired driving characteristics.

- Always check that the tyre pressures are correct.

Brakes



WARNING

Driving on unpaved or dirt roads

Delayed braking efficiency due to soiled brake disks and brake pads.

- Brake early until the brakes are clean.



ATTENTION

Riding on unsurfaced or dirty roads

Increased brake pad wear

- Check the thickness of the brake pads more frequently and replace the brake pads in good time.

Spring preload and shock-absorber settings



WARNING

Changed values for spring preload and spring strut damping for off-roading

Impaired driving characteristics on paved roads

- Before leaving the off-road terrain, set the correct spring preload and shock absorption.

Rims

BMW Motorrad recommends checking the rims for damage after off-roading.

Air filter element



ATTENTION

Dirty air filter element

Engine damage

- If you ride in dusty terrain check the air filter element for clogging at shorter intervals; clean or replace as necessary.

Operation in very dusty conditions (desert, steppes, or the like) necessitates the use of air filter elements specially designed for conditions of this nature.

SHIFTING GEAR

–with shift assistant Pro^{OE}

Gear Shift Assistant Pro



For safety reasons, adaptive cruise control is automatically deactivated when Gear Shift Assistant Pro downshifts.

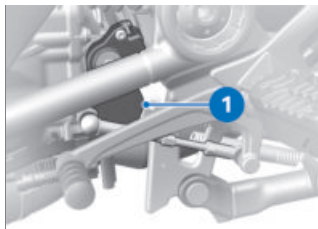

- Select the gears in the usual way by using the foot-operated gearshift lever.
 - » The shift assistant assists upshifts and downshifts without the rider having to pull the clutch or close the throttle.
 - This is not an automatic-shift system.
 - The rider is the most important part of the system and decides when to shift gears.
 - The sensor **1** on the gearshift shaft registers the gearshift request and triggers shift assistance.
 - » When riding at a steady speed in a low gear at high engine rpm, an attempt to shift gear without pulling the clutch can cause a severe load-change reaction.
 - BMW Motorrad recommends disengaging the clutch for shifts in these circumstances.
 - It is advisable to avoid using Gear Shift Assistant Pro at engine speeds close to the

142 RIDING

limits at which the governor cuts in to limit engine rpm.

- » Shift assistance is not available in the following situations:
 - With clutch lever pulled.
 - Shift lever not in its initial position
 - Upshifts with the throttle valve closed (engine overrun) and when slowing.
 - Downshifts with throttle valve open and when accelerating.
- Once the gearshift has completed, the shift lever has to be fully released before another gearshift with the Gear Shift Assistant Pro can take place.
- » See the "Engineering details" section for more information on Gear Shift Assistant Pro:
 - with riding modes Pro^{OE}
 - » Shift assistant Pro (▣▶ 168)◀

BRAKES

How can stopping distance be minimised?

Each time the brakes are applied, a load distribution shift takes place with the load shifting forward from the rear to the front wheel. The sharper the motorcycle decelerates, the more load is shifted to the front wheel. The higher the wheel load, the more brak-

ing force can be transmitted without the wheel locking. To optimise stopping distance, apply the front brakes rapidly and keep on increasing the force you apply to the brake lever. This makes the best possible use of the dynamic increase in load at the front wheel. Remember to pull the clutch at the same time. In the "emergency braking situations" that are trained so frequently, braking force is applied as rapidly as possible and with the rider's full force applied to the brake levers; under these circumstances the dynamic shift in load distribution cannot keep pace with the increase in deceleration and the tyres cannot transmit the full braking force to the surface of the road. BMW Motorrad Integral ABS Pro prevents the front wheel from locking up.

Emergency braking

If you brake sharply from a speed in excess of 50 km/h, the brake light flashes rapidly as a warning for road users behind you.

If you brake until your speed is less than 15 km/h, the hazard warning lights start to flash as well. The hazard warning

lights switch off automatically as soon as you start to accelerate and vehicle speed reaches 20 km/h.

Descending mountain passes



WARNING

Braking mostly with the rear brake on mountain descents

Brake fade, destruction of the brakes due to overheating

- Use both front and rear brakes, and make use of the engine's braking effect as well.

Wet and dirty brakes

Wetness and dirt on the brake discs and the brake pads diminish braking efficiency.

Delayed braking action or poor braking efficiency must be reckoned with in the following situations:

- Riding in the rain or through puddles of water.
- After the vehicle has been washed.
- Riding on salted or gritted roads.
- After work has been carried on the brakes, due to traces of oil or grease.
- Riding on dirt-covered surfaces or off-road.



WARNING

Wetness and dirt result in diminished braking efficiency

Risk of accident

- Apply the brakes lightly while riding to remove wetness and dirt, or dismount and clean the brakes.
- Think ahead and brake in good time until full braking efficiency is restored.

ABS Pro

Physical limits applicable to motorcycling



WARNING

Braking when cornering

Risk of crash despite ABS Pro

- Invariably, it remains the rider's responsibility to adapt riding style to riding conditions.
- Do not take risks that would negate the additional safety offered by this system.

ABS Pro and the assisting function of the Dynamic Brake Control are available in all riding modes except Enduro PRO.

144 RIDING

Possibility of a fall not precluded

Although ABS Pro and Dynamic Brake Control provide the rider with valuable assistance and constitutes a huge advance in safety for braking with the motorcycle banked for cornering, it cannot under any circumstances be considered as redefining the physical limits that apply to motorcycling. It is still possible for these limits to be overshoot due to misjudgement or rider error. In extreme cases this can result in a crash.

Use on public roads

ABS Pro and Dynamic Brake Control help make the motorcycle even safer for riding on public roads. When the brakes are applied because of an unforeseen hazard when the motorcycle is banked for cornering, within the physical limits that apply to motorcycling the ABS Pro system prevents the wheels from locking and skidding away. In panic braking, Dynamic Brake Control increases the braking effect and intervenes if the throttle grip is accidentally turned during braking.



ABS Pro was not developed to enhance individual braking performance with the motorcycle banked into corners.

PARKING YOUR MOTORCYCLE

Side stand

- Switch off the engine.



ATTENTION

Poor ground underneath the stand

Risk of damage to parts if vehicle topples

- Always check that the ground under the stand is level and firm.



ATTENTION

Additional weight placing strain on the side stand

Risk of damage to parts if vehicle topples

- Do not sit or lean on the vehicle while it is propped on the side stand.
- Extend the side stand and prop the motorcycle on the stand.
- Turn the handlebars all the way to left.

- On a gradient, the motorcycle should always face uphill; select 1st gear.

Centre stand

- Switch off the engine.



ATTENTION

Poor ground underneath the stand

Risk of damage to parts if vehicle topples

- Always check that the ground under the stand is level and firm.



ATTENTION

Centre stand retracts due to severe movements

Risk of damage to parts if vehicle topples

- Do not lean or sit on the vehicle with the centre stand extended.
- Extend the centre stand and lift the motorcycle onto the stand.
- On a gradient, the motorcycle should always face uphill; select 1st gear.

REFUELLING

Fuel grade Requirement

To ensure optimal fuel consumption, fuel should be sulphur-free or as low-sulphur as possible.



ATTENTION

Engine operation with leaded fuel

Damage to catalytic converter

- Do not attempt to run the vehicle on leaded fuel or fuel with metallic additives (e.g. manganese or iron).

- Observe the maximum ethanol content of the fuel.



Recommended fuel grade



Super unleaded (max 15 % ethanol, E10/E15)



95 ROZ/RON
90 AKI



Alternative fuel grade



Normal unleaded (power- and consumption-related restrictions.)



(max 15 % ethanol,
E10/E15)
91 ROZ/RON
87 AKI

146 RIDING

» Pay attention to the following symbols in the fuel filler cap and on the fuel pump:

E5

E10

» After refuelling with fuels of poor-quality, sporadic knocking noises may be perceptible.

Refuelling

! WARNING

Fuel is highly flammable

Risk of fire and explosion

- Do not smoke. Never bring a naked flame near the fuel tank.

! ATTENTION

Component damage

Component damage caused by overfilled fuel tank

- Overfilling the fuel tank will cause excess fuel to penetrate the carbon canister and cause component damage.
- Fill the fuel tank up to the lower edge of the filler neck only.

! ATTENTION

Wetting of plastic surfaces by fuel

Damage to the surfaces (surfaces become unsightly or dull)

- Clean plastic surfaces immediately after contact with fuel.
- Make sure the ground is level and firm and place the motorcycle on its centre stand.

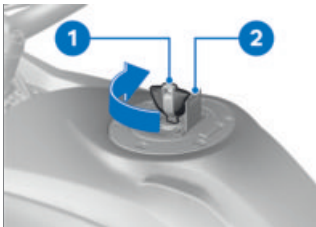



- Open the protective cap **2**.
- Unlock the cap of the fuel tank by turning ignition key **1** clockwise in the lock and pop the cap open.



- Do not fill the tank past the bottom edge of the filler neck.

 When refuelling after running on reserve, make sure that you top up the tank to a level above reserve, so that the new level is detected and the fuel reserve indicator light is switched off.

 The "usable fuel capacity" specified in the technical data is the quantity that the fuel tank could hold if refilled after it had been run dry and the engine had cut out due to a lack of fuel.

	Usable fuel capacity
	approx. 20 l
	Reserve fuel
	approx. 4 l

- Press the fuel tank cap down firmly to close.

- Remove the ignition key and close the protective cap.

Refuelling

–with Keyless Ride^{OE}

Requirement

The steering lock is disengaged.

WARNING

Fuel is highly flammable

Risk of fire and explosion

- Do not smoke. Never bring a naked flame near the fuel tank.

WARNING

Escape of fuel due to heat-induced expansion if fuel tank is overfilled

Risk of falling

- Do not overfill the fuel tank.

ATTENTION

Wetting of plastic surfaces by fuel

Damage to the surfaces (surfaces become unsightly or dull)

- Clean plastic surfaces immediately after contact with fuel.

148 RIDING

- Make sure the ground is level and firm and place the motorcycle on its centre stand.
–with Keyless Ride^{OE}
- Switch off the ignition (▮▮▮▮▶ 63).

 The fuel filler cap can be opened within the defined waiting time after the ignition has been switched off, without the radio-operated key being within range.



Waiting time for opening the fuel filler cap

2 min

- » There are **two variant ways** of opening the fuel filler cap:
- Within the waiting time.
 - After the waiting time has expired.

Version 1

–with Keyless Ride^{OE}

Requirement

Within the waiting time

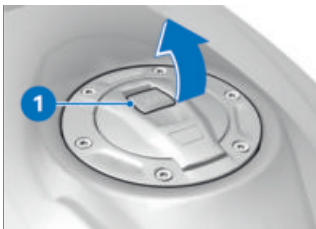

- Slowly pull tab **1** on the fuel filler cap up.
- » Fuel filler cap unlocks.
- Fully open the fuel filler cap.

Version 2

–with Keyless Ride^{OE}

Requirement

After the waiting time has expired



- Bring the radio-operated key into range.
- Slowly pull tab **1** up.
- » The indicator light for the radio-operated key flashes while the search for the radio-operated key is in progress.
- Slowly pull tab **1** on the fuel filler cap up again.
- » Fuel filler cap unlocks.
- Fully open the fuel filler cap.



- Refuel with fuel of the grade stated above; do not fill the tank past the bottom edge of the filler neck.

 When refuelling after running on reserve, make sure that you top up the tank to a level above reserve, so that the new level is detected and the fuel reserve indicator light is switched off.

 The "usable fuel capacity" specified in the technical data is the quantity that the fuel tank could hold if refilled after it had been run dry and the engine had cut out due to a lack of fuel.

	Usable fuel capacity
	approx. 20 l
	Reserve fuel
	approx. 4 l

- Press down firmly on the filler cap of the fuel tank.
- » The fuel filler cap engages with an audible click.
- » The fuel filler cap locks automatically when the waiting time expires.
- » The engaged fuel filler cap locks immediately when you secure the steering lock or switch on the ignition.

Opening fuel filler cap emergency release

–with Keyless Ride^{OE}

Fuel filler cap cannot be opened.

- Have the fault rectified as quickly as possible by a specialist workshop, preferably an authorised BMW Motorrad retailer.

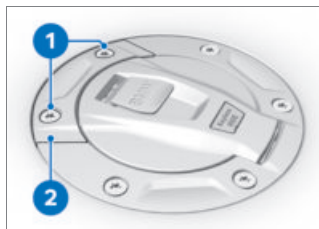

- Remove screws **1**.
- Remove emergency release **2**.
- » Fuel filler cap unlocks.
- Fully open the fuel filler cap.
- Refuelling (➡ 147).

150 RIDING

- Close the fuel filler cap emergency release (▶▶▶ 150).

Closing fuel filler cap emergency release

—with Keyless Ride^{OE}

Requirement

Fuel filler cap is in closed position.

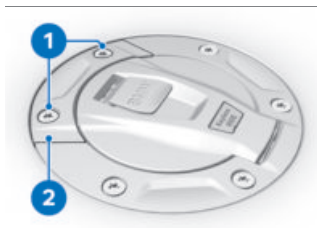

- Hold emergency release **2** in position.
- Install screws **1**.

SECURING MOTORCYCLE FOR TRANSPORTATION

- Make sure that all components that might come into contact with straps used to secure the motorcycle are adequately protected against scratching. Use adhesive tape or soft cloths, for example, for this purpose.

ATTENTION

Vehicle topples to side when being lifted on to stand

Risk of damage to parts if vehicle topples

- Secure the vehicle to prevent it toppling, preferably with the assistance of a second person.
- Push the motorcycle onto the transportation flat and hold it in position: do not place it on the side stand or centre stand.

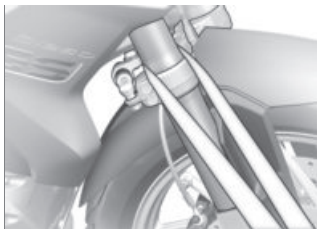
**ATTENTION****Trapping of components**

Component damage

- Do not trap components such as brake lines or cable legs.

- Pass the straps on left and right through the fork bridge and strap the motorcycle down.



- At the rear, secure the straps to the holders for the passenger footrests on both sides and tighten the straps.

- Tension all the straps uniformly to hold the vehicle securely.

ENGINEERING DETAILS

08

GENERAL NOTES	154
ANTILOCK BRAKE SYSTEM (ABS)	154
TRACTION CONTROL (DTC)	158
DYNAMIC ENGINE BRAKE CONTROL (MSR)	160
DYNAMIC ESA	160
RIDING MODE	161
DYNAMIC BRAKE CONTROL	165
TYRE PRESSURE CONTROL (RDC)	166
GEAR SHIFT ASSISTANT	168
HILL START CONTROL	169
SHIFTCAM	170
ADAPTIVE CORNERING LIGHT	171

GENERAL NOTES

To find out more about engineering go to:

bmw-motorrad.com/technology

ANTILOCK BRAKE SYSTEM (ABS)

Partially integral brakes

Your motorcycle is equipped with partially integral brakes. Both front and rear brakes are applied when you pull the handbrake lever. The foot-brake lever acts only on the rear brake.

When actively intervening in the braking process, BMW Motorrad Integral ABS Pro adapts braking-force distribution between front and rear brakes to suit the load on the motorcycle.



ATTENTION

Attempted burn-out despite Integral braking function

Damage to rear brake and clutch

- Do not burn out tyres.

How does ABS work?

The amount of braking force that can be transferred to the road depends on factors that include the coefficient of friction of the road surface. Loose stones, ice and snow or a wet road all have much lower coefficients of friction than a clean and dry asphalt surface. The lower the coefficient of friction, the longer the braking distance. If the rider increases braking pressure to the extent that braking force exceeds the maximum transferable limit, the wheels start to lock and the vehicle loses its directional stability; a fall is imminent. Before this situation occurs the ABS will be activated and the brake pressure adapted to the maximally transferable braking force. The wheels continue to turn and the driving stability is retained irrespective of the road condition.

What are the effects of surface irregularities?

Humps and surface irregularities can cause the wheels to lose contact temporarily with the road surface; if this happens the braking force that can be transmitted to the road can drop to zero. If

the brakes are applied under these circumstances the ABS has to reduce braking force to ensure that directional stability is maintained when the wheels regain contact with the road surface. At this instant the BMW Motorrad Integral ABS Pro must assume an extremely low coefficient of friction (gravel, ice, snow), so that the wheels will continue to rotate under all imaginable circumstances, because this is the precondition for ensuring directional stability. As soon as it registers the actual circumstances, the system reacts instantly and adjusts braking force accordingly to achieve optimum braking.

What feedback does the rider receive from the BMW Motorrad Integral ABS Pro?

If the ABS system has to reduce braking force on account of the circumstances described above, vibration is perceptible through the handbrake lever. When the handbrake lever is pulled, brake pressure is also built up at the rear wheel by the integral function. If the brake pedal is depressed after the handbrake lever is pulled,

the brake pressure built up beforehand is perceptible as counter-pressure sooner than is the case when the brake pedal is depressed either before or at the same time as the brake lever is pulled.

Rear wheel lift

Under very severe and sudden deceleration, however, under certain circumstances it is possible that the BMW Motorrad Integral ABS Pro will be unable to prevent the rear wheel from lifting clear of the ground. If this happens the outcome can be a highsiding situation in which the motorcycle can flip over.



WARNING

Rear wheel lift due to severe braking

Risk of falling

- When you brake sharply, bear in mind that ABS control cannot always be relied on to prevent the rear wheel from lifting clear of the ground.

156 ENGINEERING DETAILS

What is the design baseline for BMW Motorrad Integral ABS Pro?

Within the limits imposed by physics, BMW Motorrad Integral ABS Pro ensures directional stability on any surface. The system is not optimised for special requirements that apply under extreme competitive conditions off-road or on the track. The driving behaviour should be adapted to actual driving skills and the road conditions.

Special situations

The speeds of the front and rear wheels are compared as one means of detecting a wheel's incipient tendency to lock. If the system registers implausible values for a lengthy period the ABS function is deactivated for safety reasons and an ABS fault message is issued. Self-diagnosis has to complete before fault messages can be issued. In addition to problems with the BMW Motorrad ABS, exceptional riding conditions can also cause a fault message to be issued:

- Heating up with the motor-cycle on the centre stand or an auxiliary stand, engine idling or with a gear engaged.
- Rear wheel locked by the engine brake for a lengthy period, for example while descending on a loose or slippery surface.

If a fault message is issued on account of exceptional riding conditions, you can reactivate the ABS function by switching the ignition off and on again.

What significance devolves on regular maintenance?



WARNING

Brake system not regularly serviced.

Risk of accident

- In order to ensure that the ABS is always maintained in optimum condition, it is essential for you to comply strictly with the specified inspection intervals.

Safety reserves

The potentially shorter braking distances which BMW Motorrad Integral ABS Pro permits must not be used as an excuse for careless riding. The system is

primarily a means of ensuring a safety margin in genuine emergencies.



WARNING

Braking when cornering

Risk of accident despite ABS

- Invariably, the rider bears responsibility for assessing road and traffic conditions and adopting his or her style of riding accordingly.
- Do not take risks that would negate the additional margin of safety offered by this system.

Evolution of ABS to ABS Pro

Until now, the BMW Motorrad ABS helped ensure a very high degree of safety for braking with the motorcycle upright and travelling in a straight line. Now ABS Pro offers enhanced safety for braking in corners as well. ABS Pro prevents the wheels from locking even under sharp braking. ABS Pro reduces abrupt changes in steering force, particularly in panic-braking situations, counteracting the vehicle's otherwise natural but undesirable tendency to straighten up.

ABS intervention

Technically speaking, depending on the riding situation ABS Pro adapts ABS intervention to the motorcycle's bank angle. Signals for rate of roll and rate of yaw and lateral acceleration are used to calculate bank angle. As the motorcycle is heeled over more and more as it banks into a corner, an increasingly strict limit is imposed on the brake-pressure gradient for the start of brake application. This slows the build-up of brake pressure to a corresponding degree. Additionally, pressure modulation is more uniform across the range of ABS intervention.

Advantages for the rider

The advantages of ABS Pro for the rider are sensitive response and high braking and directional stability combined with best-case deceleration of the motorcycle, even when cornering.

TRACTION CONTROL (DTC)

How does traction control work?

Traction control compares the front and rear wheel circumferential velocities. The differential is used to compute slip as a measure of the reserves of stability available at the rear wheel. If slip exceeds a certain limit, the engine management system intervenes and adapts engine torque accordingly. Dynamic Traction Control (DTC) takes bank angle into consideration and on account of this additional bank-angle and acceleration data, its intervention is more precise and more comfortable for the rider. BMW Motorrad DTC is designed as an assistant system for the rider and for use on public roads. The extent to which the rider affects DTC control can be considerable (weight shifts when cornering, items of luggage loose on the motorcycle), especially when the style of riding takes rider and machine close to the limits imposed by physics.

Activate **Enduro** riding mode for off-roading. This mode delays DTC intervention slightly

in order to permit controlled drifting.

The system is not optimised for special requirements that apply under extreme competitive conditions off-road or on the track. The BMW Motorrad DTC can be deactivated in these cases.



WARNING

Risky riding

Risk of accident despite DTC

- Invariably, the rider bears responsibility for assessing road and traffic conditions and adopting his or her style of riding accordingly.
- Do not take risks that would negate the additional safety offered by this system.

Special situations

In accordance with the laws of physics, the ability to accelerate is restricted more and more as the angle of heel increases. Consequently, there can be a perceptible reduction in acceleration out of very tight bends.

If the electronic processor receives values for the bank angle that it considers implausible over a lengthy period, a dummy value is used for the bank angle or the DTC function

is switched off. Under these circumstances the indicator for a DTC fault shows. Self-diagnosis has to complete before fault messages can be issued.

The BMW Motorrad Traction Control can shut down automatically under the exceptional riding conditions outlined below.

Exceptional riding conditions:

- Riding for a lengthy period with the front wheel lifted off the ground (wheelie).
- Rear wheel rotating with the vehicle held stationary by application of the front brake (burn-out).
- Heating up with the motorcycle on an auxiliary stand, in neutral or with a gear engaged.

If the front wheel lifts clear of the ground under severe acceleration, the DTC reduces engine torque in the RAIN and ROAD riding modes until the front wheel regains contact with the ground.

In the DTC settings DYNAMIC and ENDURO, front wheel lift-off detection allows short wheelies.

In the DTC settings DYNAMIC PRO and ENDURO PRO, front-

wheel lift-off detection is switched off.

The ENDURO and ENDURO PRO riding modes are set up for off-road riding and are not suitable for on-road riding.

In ECO riding mode, the DTC setting corresponds to the ROAD riding mode.

in RAIN, ROAD, DYNAMIC, DYNAMIC PRO, ENDURO and ENDURO PRO riding modes, the DTC setting corresponds to the riding mode.

In DYNAMIC PRO and ENDURO PRO riding modes, DTC can be set up differently (► 80). BMW Motorrad recommends turning the throttle grip back slightly when lifting the front wheel in order to reach a stable driving condition again as soon as possible.

When riding on a slippery surface, never snap the throttle twistgrip fully closed without pulling the clutch at the same time. Engine braking torque can cause the rear wheel to skid, with a corresponding loss of stability. The BMW Motorrad DTC is unable to control a situation of this nature. With dynamic engine brake control, this loss of stability can be prevented.

DYNAMIC ENGINE BRAKE CONTROL (MSR)

—with riding modes Pro^{OE}

How does dynamic engine brake control work?

The purpose of dynamic engine brake control is to prevent the unstable riding states that can be produced by excessive engine braking moment acting on the rear wheel. Depending on the road condition and riding dynamic, excessive braking torque can produce a sharp rise in rear-wheel slip and impair directional stability. Dynamic engine brake control limits this slip at the rear wheel to a safe mode-dependent and bank-angle-dependent regulated slip.

Causes for excessive slip at the rear wheel:

- Riding with engine overrun on a surface with a low coefficient of friction (e.g. wet leaves).
- Rear-wheel hop when rider downshifts.
- Sharp braking during sporty riding.

In the same way as DTC traction control, dynamic engine brake control compares the wheel circumferential velocities

of the front and rear wheels. Additional information on the bank angle enables dynamic engine brake control to calculate slip and the reserve of stability at the rear wheel. If slip overshoots the applicable limit, the throttle valves are opened very slightly to increase engine torque. Slip is reduced and the vehicle is stabilised.

Effect of dynamic engine brake control

- In ECO, RAIN and ROAD riding modes: maximum stability.
- In the DYNAMIC and DYNAMIC PRO riding modes: high stability.
- In ENDURO riding mode: minimum stability.
- In ENDURO PRO riding mode, dynamic engine brake control is inactive.

DYNAMIC ESA

—with Dynamic ESA^{OE}

Riding position equaliser

Dynamic ESA is an electronic system that enables your motorcycle's suspension to adjust automatically to suit the load the vehicle is carrying. When spring preload is set to *Auto*, the rider does not have to ad-

just the suspension to suit the load.

When driving off and when riding, the system monitors the suspension on the rear wheel and corrects the spring preload in order to set the riding position correctly. The damping is also adjusted automatically to the load.

By interpreting ride height sensor signals, Dynamic ESA detects movements in the suspension and responds by adjusting the damper valves. This enables the suspension to adapt to the terrain. Dynamic ESA calibrates itself at regular intervals to ensure the system functions correctly.

Possibilities for adjustment

Damping modes

- Road: damping for comfortable on-road riding
- Dynamic: damping for dynamic on-road riding
- Enduro: damping for off-road riding

Load settings

- Auto: active ride compensation with automatic adjustment of spring preload and damping
- Min: minimum spring preload

- Max: maximum spring preload (for off-road use)
- The Min and Max spring preloads can be selected by the rider but not changed. The ride compensation function is inactive in the Min and Max settings.

RIDING MODE

Selection

To adjust the motorcycle to the road condition and the desired driving experience, the following riding modes can be selected:

- ECO
- RAIN
- ROAD (default mode)
- with riding modes Pro^{OE}
- ENDURO
- DYNAMIC
- ENDURO PRO
- DYNAMIC PRO

With the riding modes Pro optional equipment, the ROAD, RAIN, ECO and ENDURO riding modes are always activated by default. The other riding modes can be selected in the riding modes preselection. A maximum of four riding modes can be preselected at any given time.

162 ENGINEERING DETAILS

For each of these riding modes, there is a matching setting for the DTC, ABS and MSR systems and for the engine characteristic.

–with Dynamic ESA^{OE}

The adjustment of the Dynamic ESA also depends on the riding mode selected.

DTC can be switched off in each riding mode. The explanations below always refer to the dynamic safety systems that are switched on.

Throttle response

- In ECO riding mode: very restrained
- In RAIN and ENDURO riding modes: restrained
- In ROAD and ENDURO PRO riding modes: optimal
- In DYNAMIC and DYNAMIC PRO riding modes: direct
- In DYNAMIC PRO and ENDURO PRO riding modes, the throttle response can be set differently via SETUP (▣▣▣ 77).

ABS

Setting

- In ROAD, DYNAMIC, ENDURO and ENDURO PRO riding modes, the ABS setting corresponds to the riding mode.

- In ECO and RAIN riding modes, the ABS setting corresponds to the ROAD riding mode.
- In DYNAMIC PRO riding mode, the ABS setting corresponds to the DYNAMIC riding mode.
- In DYNAMIC PRO and ENDURO PRO riding modes, the ABS can be set differently via SETUP (▣▣▣ 80).

Tuning setup

- In ECO, RAIN, ROAD, DYNAMIC and DYNAMIC PRO riding modes, the ABS is set up for on-road riding.
- In ENDURO riding mode, the ABS is set up for off-road riding with road tyres.
- In ENDURO PRO riding mode, there is no ABS control at the rear wheel when the foot-brake lever is operated. The ABS is set up for off-road riding with cleated tyres.

Rear-wheel lift-off detection

- In ECO, RAIN, ROAD and ENDURO riding modes, the rider has maximum assistance from rear-wheel lift-off detection.
- In DYNAMIC and DYNAMIC PRO riding modes, rear-wheel lift-off detection offers re-

duced assistance and allows slight lift-off of the rear wheel.

- Rear wheel lift-off detection is inactive in ENDURO PRO riding mode.

ABS Pro

- In ECO, RAIN and ROAD riding modes, ABS Pro is fully available.
- In DYNAMIC, DYNAMIC PRO and ENDURO riding modes, ABS Pro assistance is reduced by comparison with ECO, RAIN and ROAD riding modes.
- In the ABS setting DYNAMIC PRO, ABS Pro is not available.
- ABS Pro is not available in ENDURO PRO riding mode. It can be switched on by changing to the ABS setting ENDURO.

DTC

Tyres

- In the DTC settings RAIN, ROAD and DYNAMIC, DTC is set up for on-road riding with road tyres.
- In the DTC setting ENDURO, DTC is set up for off-road riding with road tyres.
- In the DTC setting ENDURO PRO, DTC is set up for off-road riding with cleated tyres.

Riding stability

- In the DTC setting RAIN, DTC intervenes early enough to achieve maximum riding stability.
- In the DTC settings of the ECO and ROAD riding modes, DTC intervenes later than in RAIN riding mode. This prevents the rear wheel from spinning whenever possible.
- In the DTC settings ECO, RAIN and ROAD, the front wheel is prevented from lifting off.
- In the DTC setting DYNAMIC, DTC intervenes later than in the DTC setting ROAD, so slight drift can be induced when exiting corners and brief wheelies are also possible.
- In the DTC setting ENDURO, DTC intervenes even later than in the other modes and the set-up is for off-road riding, so lengthy drifts and short wheelies when exiting corners are possible.
- In the DTC setting ENDURO PRO, DTC control assumes that the vehicle is being ridden off-road and is fitted with cleated tyres. The front wheel lift-off detection is switched off, so that wheelies of any

164 ENGINEERING DETAILS

length and angle are possible. In extreme cases, the vehicle can flip over backwards!

In RAIN, ROAD, DYNAMIC and ENDURO riding modes, the DTC setting corresponds to the riding mode.

In ENDURO PRO and DYNAMIC PRO riding modes, DTC can be set up differently (▶▶▶ 80).

Mode changes

The riding mode can be changed while the vehicle is stationary with the ignition on. Under the following precondition, it is also possible to change modes while riding:

- No drive torque on the rear wheel.
- No brake pressure in the brake system.

The following steps must be taken to change the riding mode:

- Close the throttle twistgrip.
- Release the brake levers.
- Deactivate adaptive cruise control.

The desired riding mode is initially preselected. The mode change does not take place until the systems in question are all in the appropriate state. The selection menu does not disappear from the display until

the mode change has taken place.

ECO mode with ShiftCam technology

ShiftCam technology is the bridge-builder between ultra-high dynamism and maximum efficiency. The full-load cams allow full valve lift for maximum combustion-chamber charge and high power, whereas the part-load cams considerably shorten the lift of the intake valves and open the valves to different extents. Charge-cycle losses are lessened by de-throttling, friction is reduced, the mixture is swirled more vigorously and combusted more effectively, fuel consumption goes down.

The ECO mode assists the rider with ECO indicator and engine characteristic (parametrisation of the electromotive throttle controller) to keep the engine in the operating range of the consumption-oriented part-load cam, so as to maximise the distance travelled with a given quantity of fuel.

The length of the green bar in the ECO indicator in the TFT display visualises whether the drive is operating in the

consumption-optimised range of the part-load cam and the margin from the switch-over threshold to full-load cam operation. The length of the bar represents the load reserve left before the switch-over point for full-load cam operation is reached. The colour changes to grey when load requirement increases and the engine switches to the full-load cam. The reading shown by the ECO indicator varies depending on the gear selected by the rider, the load requirement input via the throttle grip, and engine rpm. Even outside the operating range of the part-load cam, when the bar is grey, the ECO offers benefits for an economical style of riding by reducing maximum available torque and peak power.

 Because of the reduced acceleration ability in ECO mode, changing to a different riding mode is recommended prior to critical overtaking manoeuvres with the motorcycle heavily loaded or when riding two-up.

Rider can further reduce consumption by riding with fuel economy in mind ( 170) .

DYNAMIC BRAKE CONTROL

–with riding modes Pro^{OE}

How Dynamic Brake Control works

 The Dynamic Brake Control function is active in all riding modes. It can be deactivated in the DYNAMIC PRO and ENDURO PRO riding modes only, by custom parametrisation of the ABS.

The Dynamic Brake Control function assists the rider in emergency braking situations.

Detection of emergency braking

–Sudden, sharp application of the front brake is interpreted as emergency braking.

Behaviour in emergency braking

–If emergency braking occurs at a speed in excess of 10 km/h, the ABS function is further assisted by Dynamic Brake Control.
–If partially integral braking at a high brake pressure gradient is initiated Dynamic Brake Control increases the integral brake pressure at the rear wheel. The stopping distance

166 ENGINEERING DETAILS

shortens and controlled braking is possible.

Behaviour during accidental actuation of the throttle grip

- If the throttle is accidentally opened (throttle grip position > 5 %) during emergency braking, Dynamic Brake Control ensures the desired braking effect by ignoring actuation of the throttle grip. The effectiveness of emergency braking is ensured.
- If the throttle is closed (throttle grip position < 5 %) while Dynamic Brake Control is in action, the engine torque requested by the ABS brake system is restored.
- If emergency braking ceases and the rider still has not changed the position of the throttle grip, Dynamic Brake Control steadily ramps engine torque back to the rider's requested level.

 The function of the Dynamic Brake Control is switched off at the same time as the ABS is switched off.

TYRE PRESSURE CONTROL (RDC)

-with tyre pressure control (RDC)^{OE}

Function

A sensor integrated into each tyre measures the air temperature and the air pressure inside the tyre and transmits this information to the control unit. The sensors are fitted with a centrifugal-force tripswitch which allows the measured values to be transmitted after the minimum speed is exceeded the first time.

 Minimum speed for transmission of the RDC measured values:

min 30 km/h

The display shows -- for each tyre until the tyre-pressure signal is received for the first time. The sensors continue to transmit the measured-value signals for some time after the vehicle comes to a stop.

 Transmission duration of the measured values after vehicle standstill:

min 15 min

An error message is issued if wheels without sensors are fit-

ted to a vehicle equipped with an RDC control unit.

Tyre pressure ranges

The RDC control unit distinguishes between three tyre pressure ranges matched to the vehicle:

- Filling pressure within the permissible tolerance
- Filling pressure in the limit range of the permissible tolerance
- Filling pressure outside permitted tolerance

Temperature compensation

Tyre pressure is a temperature-sensitive variable: pressure increases as tyre-air temperature rises and decreases as tyre-air temperature drops. Tyre-air temperature depends on ambient temperature as well as on the style of riding and the duration of the ride.



The tyre pressures are shown in the TFT display as temperature compensated and always refer to the following tyre air temperature:

20 °C

The air lines available to the public in petrol stations and motorway service areas have gauges that do not compensate

for temperature; the reading shown by a gauge of this nature is the temperature-dependent tyre-air pressure. As a result, the values displayed there usually do not correspond to the values displayed in the TFT display.

Pressure adaptation

Compare the RDC value on the TFT display with the value in the table on the back cover of the Rider's Manual. Then use the air-line gauge at a service station to compensate for the difference between the RDC reading and the value in the table.



Example

According to the rider's manual, the tyre pressure should be the following value:

2.5 bar

The following display is shown in the TFT display:

2.3 bar

Missing:

0.2 bar

The tester on the filling station shows:

2.4 bar



Example

The tyre pressure must be increased to the following value to reach the correct tyre pressure:

2.6 bar

GEAR SHIFT ASSISTANT

–with riding modes Pro^{OE}

Shift assistant Pro

Your vehicle is equipped with a Pro shift assistant, a system originally developed for racing and now adapted for touring. It permits upshifts and downshifts without declutching or closing the throttle in virtually all load and rpm ranges.

Advantages

- 70-80 % of all gearshifts on a trip can be done without using the clutch.
- Less relative movement between rider and passenger because the shift pauses are shorter.
- It is not necessary to close the throttle valve when shifting under acceleration.
- When braking and downshifting (throttle valve closed), engine speed is adjusted by blipping the throttle.

–Shift time is shorter than a gearshift with clutch actuation.

In order for the system to identify a gearshift request, the rider has to move the gearshift lever from its idle position in the desired direction against the spring force through a certain "overtravel" at ordinary speed or rapidly and keep the gearshift lever in this position until the gearshift is completed. It is not necessary to increase the force applied to the shift lever while shifting is in progress. Once the gearshift has completed the shift lever has to be fully released before another gearshift with the Pro shift assistant can take place. When shifting gears with the Pro shift assistant, the rider has to keep load state (throttle grip position) constant before and during the gearshift. A change in the position of the throttle grip during a gearshift can cause the function to abort and/or lead to a missed shift. The Pro shift assistant provides no assistance for the gearshift if the rider declutches.



Downshifting

–Downshifting is assisted until maximum rpm for the target gear to be selected is reached. This prevents over-revving.

 Maximum engine speed
max 9000 min ⁻¹

Upshifting

–Upshifting is only possible when the current speed is higher than the respective release threshold of the next higher gear.
–This prevents the engine from dropping below idle speed.

 Idle speed
1050 min ⁻¹ (Engine at regular operating temperature)
 Release thresholds
1st gear
min 1350 min ⁻¹
2nd gear
min 1400 min ⁻¹
3rd gear
min 1450 min ⁻¹
4th gear
min 1500 min ⁻¹

 Release thresholds
5th gear
min 1550 min ⁻¹
6th gear
min 1600 min ⁻¹

HILL START CONTROL

Hill Start Control function

Hill Start Control assistant prevents the motorcycle from rolling backwards uncontrolled on gradients by intervening specifically with the ABS brake system without the driver having to constantly operate the brake lever. Pressure in the rear brake system is built up when Hill Start Control is activated in order to keep the motorcycle stationary on an incline.

The brake pressure in the brake system is dependent on the gradient.

Effect of an incline on brake pressure and drive-off behaviour

–If the motorcycle is stopped on a gentle incline, only low brake pressure is built up. In this case, the brakes are quickly released when driving off. The motorcycle can be moved off more gently. It

170 ENGINEERING DETAILS

is not necessary to turn the throttle grip again.

- If the motorcycle is stopped on a steep incline, high brake pressure is built up. In this case, the brakes take longer to release when driving off. More torque is required for driving off which also requires the rider to turn the throttle grip again.

Behaviour when the motorcycle rolls or slips

- If the motorcycle rolls when Hill Start Control is activated, the brake pressure is increased.
- If the rear wheel slips, the brake is released again after approx. 1 m. This prevents, for example, slipping due to a blocked rear wheel.

Releasing brake when stopping the engine or timeout

Hill Start Control is deactivated when the engine is stopped using the emergency-off switch, when the side stand is folded out or after timeout (10 minutes).

In addition to the indicator and warning lights, the rider should be made aware that Hill Start

Control has been deactivated by the following behaviour:

Brake warning jolt

- The brake is released briefly and reactivated immediately.
- This creates a jolt which the rider feels.
- The ABS brake system with partially integral function sets a speed of approx. 1-2 km/h.
- The rider must brake the motorcycle manually.
- After two minutes, or when the brake is actuated, Hill Start Control is completely deactivated.



The holding pressure is released immediately without a brake warning jolt as soon as the ignition is switched off.

SHIFTCAM

Functional principle of ShiftCam

The vehicle features BMW ShiftCam technology for varying valve timing and valve lift on the intake side. The heart of this technology is a one-piece shifting intake camshaft that has two lobes for each valve: a partial-load cam and a full-load cam. The partial-load cam is fine-tuned for consumption optimisation

and engine smoothness. As well as adapting valve timing, the partial-load cam also reduces intake-valve lift. With the partial-load cams activated, moreover, the lobes for the cylinder's left and right intake valves produce staggered valve lift and offset angles of rotation. Consequently the two intake valves open at very slightly different times and the distance to which they open also differs. The advantage: The fuel/air mixture flowing into the combustion chamber is swirled more thoroughly and combusted effectively - so all in all the fuel is utilised more efficiently and engine operation is perceptibly smoother. The full-load cam is designed for optimised engine power and it maximises intake valve lift. The intake camshaft is shifted axially to vary valve timing and valve lift. The pins of an electromechanical actuator engage a shift gate on the intake camshaft. This permits load-dependent and speed-dependent actuation of the intake valves and, consequently, a no-compromises combination of performance and low fuel consumption.

ADAPTIVE CORNERING LIGHT

—with adaptive head light^{OE}

How does the adaptive cornering headlight work?

The low-beam unit installed as standard in the headlight consists of two reflectors that produce a low beam from an LED light source. Ride height sensors on front and rear suspension supply data for permanent beam throw adjustment. While the motorcycle is moving straight ahead, pitch compensation keeps the throw of the headlight beam constantly in the optimum, preset range, regardless of ride and load state. With the Adaptive headlight function, the low-beam unit is additionally rotated about an axis to a degree that varies with the bank angle, compensating for the vehicle's angle of lean. The angle of rotation is 70° (±35°). Along with pitch compensation, therefore, the throw of the low-beam headlight also compensates for the rider's chosen bank angle through corners. The two movements are superimposed, so as the motorcycle is steered through a bend the

172 **ENGINEERING DETAILS**

headlight beam is directed into the bend for better illumination of the road ahead. The results are considerably better illumination of the road ahead when the motorcycle corners, and a huge increase in active riding safety.

MAINTENANCE

09

GENERAL NOTES	176
TOOLKIT	177
SERVICE TOOL KIT	177
FRONT-WHEEL STAND	178
ENGINE OIL	179
BRAKE SYSTEM	181
CLUTCH	185
COOLANT	185
TYRES	187
RIMS AND TYRES	188
WHEELS	189
AIR FILTER	195
LIGHTING	197
JUMP-STARTING	197
BATTERY	199
FUSES	203
DIAGNOSTIC CONNECTOR	205

GENERAL NOTES

The Maintenance chapter describes straightforward procedures for checking and replacing certain wear parts.

Microencapsulated screws

The microencapsulation is a chemical thread-locker. An adhesive compound creates a secure connection between bolt and nut or between screw and component. Consequently, microencapsulated screws are for once-only use and are not intended for re-installation after being slackened.

After removal of the screw, clean the internal thread to remove all traces of thread-locking compound. Always use new microencapsulated screws when re-assembling. Consequently, prior to disassembly make sure that you have suitable tools for cleaning the threads and a new replacement for each screw to be removed. If the job is not done correctly there is no guarantee that the screw will remain secure, which means that you would be putting yourself at risk!

Further information

Special tightening torques are listed as applicable. The tightening torques for the threaded fasteners on your vehicle are listed in the section entitled "Technical data".

You will find information on more extensive maintenance and repair work in the repair manual on DVD for your vehicle, available from your authorised BMW Motorrad retailer.

Some of the work calls for special tools and a thorough knowledge of the technology involved. If you are in doubt, consult a specialist workshop, preferably your authorised BMW Motorrad retailer.

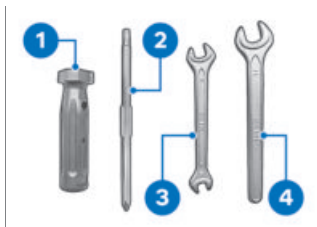
TOOLKIT

- 1** Screwdriver handle
 –Use with screwdriver insert
 –Top up the engine oil (▮▮▮ 180).
- 2** Reversible screwdriver blade
 Phillips PH1 and Torx T25
 –Remove the battery cover (▮▮▮ 201).
- 3** Open-ended spanner
 Width across flats 8/10
 –Removing battery (▮▮▮ 201).
- 4** Open-ended spanner
 Width across flats 14
 –Adjust the mirror arm (▮▮▮ 116).

SERVICE TOOL KIT

–with service toolkit^{OA}

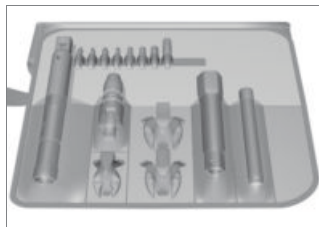

BMW Motorrad has assembled a service toolkit that is ideal for carrying out extended service work (e.g. removing and installing wheels) on this motorcycle. This toolkit is available from your authorised BMW Motorrad retailer.

FRONT-WHEEL STAND

Installing front-wheel stand



ATTENTION

Use of the BMW Motorrad front wheel stand without accompanying use of centre stand or auxiliary stand

Risk of damage to parts if vehicle topples

- Place the motorcycle on its centre stand or another auxiliary stand before lifting the front wheel with the BMW Motorrad front-wheel stand.
- Make sure the ground is level and firm and place the motorcycle on its centre stand.
- Use basic stand with front-wheel adapter. The basic stand and its accessory components are available from your BMW Motorrad authorised dealer.

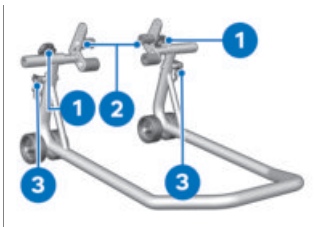

- Slacken screws **1**.
- Push the two adapters **2** apart until the front forks fit between them.
- Use locating pins **3** to set the front-wheel stand to the desired height.
- Centre the front wheel stand relative to the front wheel and push it into position at the front axle.

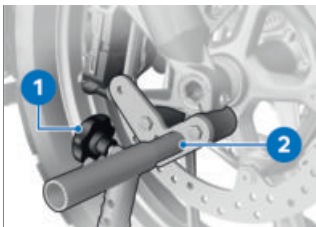

- Align the two adapters **2** so that the front forks are securely seated.
- Tighten screws **1**.



ATTENTION

Centre stand lifts clear if the motorcycle is lifted too high

Risk of damage to parts if vehicle topples

- When lifting, make sure that the centre stand remains in contact with the ground.

- Apply uniform pressure to push the front-wheel stand down and raise the motorcycle.

ENGINE OIL

Checking engine oil level

 Incorrect interpretation of the oil capacity is possible because the oil level is temperature-dependent.

- Check that the engine is at operating temperature, make sure the ground is level and firm and place the motorcycle on its centre stand.

- Allow the engine to idle until the fan cuts in.
- Switch off the engine when it is at operating temperature.
- Wait five minutes for the oil to drain into the oil pan.

 To protect the environment, BMW Motorrad recommends occasionally checking the engine oil after a journey of at least 50 km.

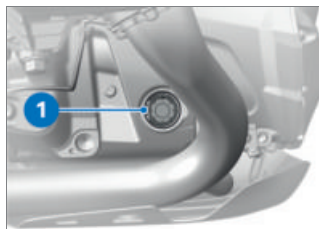

ATTENTION

Vehicle toppling sideways

Risk of damage to parts if vehicle topples

- Secure the vehicle, preferably with the assistance of a second person, so that it cannot topple sideways.
- Check the oil level in the display **1**.

180 MAINTENANCE

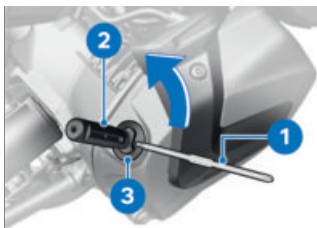
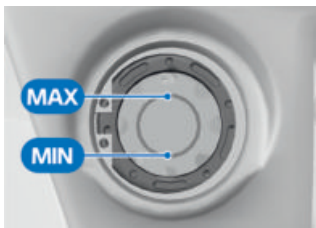

Engine oil, specified level

Between **MIN** and **MAX** marks

If the oil level is below the MIN mark:

- Top up the engine oil (▶▶▶ 180).

If the oil level is above the MAX mark:

- Have the oil level corrected by a specialist workshop, preferably an authorised BMW Motorrad retailer.

Topping up engine oil

- Make sure the ground is level and firm and place the motorcycle on its stand.
- Check the engine oil level



Incorrect interpretation of the oil capacity is possible because the oil level is temperature-dependent.

- Wipe the area around the oil filler opening clean.
- Insert Torx end of reversible screwdriver insert **1** into screwdriver handle **2** (toolkit) for additional leverage.
- Engage this tool in cap **3** of the oil filler opening and turn anti-clockwise to remove.
- Check the engine oil level (▶▶▶ 179).



ATTENTION

Use of insufficient engine oil or too much engine oil

Engine damage

- Always make sure that the oil level is correct.
- Top up the engine oil to the specified level.



Engine oil, quantity for topping up

max 0.8 l (Difference between MIN and MAX)

- Check the engine oil level (▶▶▶ 179).

- Install cap **3** of the oil filler opening.

BRAKE SYSTEM

Checking function of brakes

- Pull the front brake lever.
 - » The pressure point must be clearly perceptible.
 - Press the footbrake lever.
 - » The pressure point must be clearly perceptible.
- If pressure points are not clearly perceptible:



ATTENTION

Work on brake system not in compliance with correct procedure

Risk to operational reliability of the brake system

- Have all work on the brake system undertaken by trained and qualified specialists.
 - Have the brakes checked by a specialist workshop, preferably an authorised BMW Motorrad dealer.
- ### Checking brake pad thickness, front brakes
- Make sure the ground is level and firm and place the motorcycle on its stand.

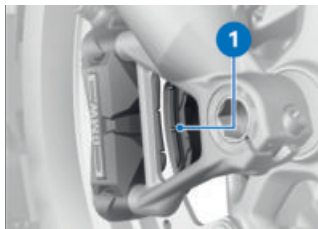

- Visually inspect the left and right brake pads to ascertain their thickness. Viewing direction: between wheel and front suspension toward brake pads **1**.

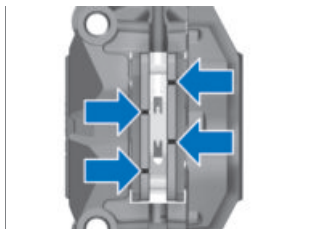

 Brake-pad wear limit, front

1.0 mm (Friction pad only, without backing plate. The wear indicators (grooves) must be clearly visible.)

If the wear indicating marks are no longer clearly visible:

WARNING

Brake-pad thickness less than permissible minimum

Diminished braking effect, damage to the brakes

- In order to ensure the dependability of the brake system, do not permit the brake pads to wear past the minimum permissible thickness.
 - Have the brake pads replaced by a specialist workshop, preferably an authorised BMW Motorrad retailer.
- #### **Checking brake pad thickness, rear brakes**
- Make sure the ground is level and firm and place the motorcycle on its stand.



- Visually inspect the brake pads to ascertain their thickness. Viewing direction: between spray guard and rear wheel toward brake pads **1**.

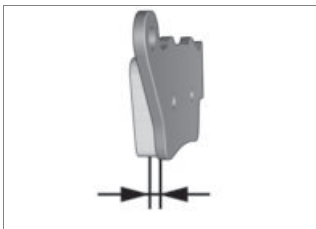

 Brake-pad wear limit, rear

1.0 mm (Friction pad only, without backing plate.)

If the wear limit has been reached:

**WARNING****Brake-pad thickness less than permissible minimum**

Diminished braking effect, damage to the brakes

- In order to ensure the dependability of the brake system, do not permit the brake pads to wear past the minimum permissible thickness.
- Have the brake pads replaced by a specialist workshop, preferably an authorised BMW Motorrad retailer.

Checking brake-fluid level, front brakes**WARNING****Not enough brake fluid in brake fluid reservoir, or contaminants in brake fluid**

Considerably reduced braking power due to presence of air, contaminants or water in the brake system

- Cease operation of the vehicle immediately and do not ride it until the fault has been rectified.
- Check the brake-fluid levels at regular intervals.
- Always make sure that the lid of the brake fluid reservoir and the area around the lid are cleaned before opening.
- Make sure that only fresh brake fluid from a sealed container is used.
- Make sure the ground is level and firm and place the motorcycle on its centre stand.
- Move the handlebars to the straight-ahead position.

184 MAINTENANCE



- Check the brake fluid level in brake fluid reservoir for front wheel brake **1**.



Wear of the brake pads causes the brake fluid level in the reservoir to sink.



Brake fluid level, front

Brake fluid, DOT4

It is not permissible for the brake fluid level to be below the **MIN** mark. (Brake-fluid reservoir horizontal, motorcycle upright)

If the brake fluid level drops below the permitted level:

- Have the fault rectified as quickly as possible by a specialist workshop, preferably an authorised BMW Motorrad retailer.

Checking brake-fluid level, rear brakes



WARNING

Not enough brake fluid in brake fluid reservoir, or contaminants in brake fluid

Considerably reduced braking power due to presence of air, contaminants or water in the brake system

- Cease operation of the vehicle immediately and do not ride it until the fault has been rectified.
 - Check the brake-fluid levels at regular intervals.
 - Always make sure that the lid of the brake fluid reservoir and the area around the lid are cleaned before opening.
 - Make sure that only fresh brake fluid from a sealed container is used.
- Make sure the ground is level and firm and place the motorcycle on its centre stand.



- Check the brake fluid level in brake fluid reservoir for rear wheel brake **1**.

 Wear of the brake pads causes the brake fluid level in the reservoir to sink.



Brake fluid level, rear

Brake fluid, DOT4

It is not permissible for the brake fluid level to be below the **MIN** mark. (Brake-fluid reservoir horizontal, motorcycle upright)

If the brake fluid level drops below the permitted level:

- Have the fault rectified as quickly as possible by a specialist workshop, preferably an authorised BMW Motorrad retailer.

CLUTCH

Checking clutch function

- Pull the clutch lever.
- » The pressure point must be clearly perceptible.

If the pressure point is not clearly perceptible:

- Have the clutch checked by a specialist workshop, preferably an authorised BMW Motorrad dealer.

COOLANT

Checking coolant level

- Make sure the ground is level and firm and place the motorcycle on its stand.

186 MAINTENANCE



If the coolant drops below the permitted level:

- Top up the coolant (➔ 186).

Topping up coolant

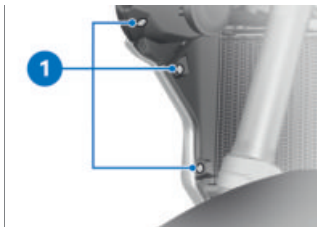

- Remove screws **1**.



- Remove screws **1**.
- Pull and remove side trim panel **2** from the clamp **3**.

CAUTION

Hot engine

Risk of burn injury

- Keep ell clear of all hot engine components.
 - Do not touch hot engine components.
-
- Check the coolant level in expansion tank **1**.



Specified coolant level

Between **MIN** and **MAX** marks on the expansion tank (Engine cold)



- Open cap **1**.
- Top up coolant to specified level.
- Check the coolant level (▮▮▮▮▶ 185).
- Close the cap of the expansion tank.



- Install screws **1**.



- Insert side panel **1** into slots **2**.
- Engage clamp **3**.

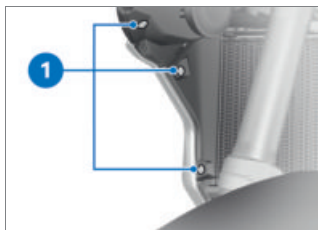

- Install screws **1**.

TYRES

Checking tyre pressures



WARNING

Incorrect tyre pressure

Impaired handling characteristics of the motorcycle, shorter useful tyre life

- Always check that the tyre pressures are correct.



WARNING

Tendency of valve inserts installed vertically to open by themselves at high riding speeds

Sudden loss of tyre pressure

- Install valve caps fitted with rubber sealing rings and tighten firmly.

- Make sure the ground is level and firm and place the motorcycle on its stand.
- Check tyre pressures against the data below.



Tyre pressure, front

2.5 bar (sport riding)

2.5 bar (One-up, tyre cold)

2.5 bar (Two-up mode with load, with cold tyres)



Tyre pressure, rear

2.9 bar (One-up, tyre cold)

2.9 bar (Two-up mode with load, with cold tyres)

If tyre pressure is too low:

- Correct tyre pressure.



Tyre pressures can be determined with tyre pressure control (RDC). The tyre-pressure readings shown in the instrument cluster are tempe-

perature-compensated and are always referenced to a tyre air temperature of 20 °C. The gauges on forecourt air lines do not compensate for temperature. Consequently, the values they show do not usually tally with the pressure readings shown by the TFT display.

RIMS AND TYRES

Checking rims

- Place the motorcycle on its stand on firm, even ground.
- Visually inspect the rims for defects.
- Have damaged rims inspected by a specialist workshop and replaced if necessary, preferably by an authorised BMW Motorrad dealer.

Checking tyre tread depth



WARNING

Riding with badly worn tyres

Risk of accident due to impaired handling

- If applicable, have the tyres changed in good time before they wear to the minimum tread depth permitted by law.

- Place the motorcycle on its stand on firm, even ground.

- Measure the tyre tread depth in the main tread grooves with wear marks.



Wear indicators are built into the main profile grooves on each tyre. The tyre is worn out when the tyre tread has worn down to the level of the marks. The locations of the marks are indicated on the edge of the tyre, e.g. by the letters TI, TWI or by an arrow. If the tyre tread is worn to minimum:

- Replace tyre or tyres, as applicable.

Checking spokes

—with cross-spoked wheels^{OE}

- Place the motorcycle on its stand on firm, even ground.
- Use a screwdriver handle or similar object to brush over the spokes and pay attention to the sequence of sounds.

If the sequence of sounds is irregular:

- Have the spokes checked by a specialist workshop, preferably by an authorised BMW Motorrad Retailer.

WHEELS

Effect of wheel size on chassis and suspension control systems

Wheel size is very important as a parameter for the ABS running-gear control system. In particular, the diameter and the width of a vehicle's wheels are programmed into the control unit and are fundamental to all calculations. Any change in these influencing variables, caused for example by a switch to wheels other than those installed ex-works, can have serious effects on the performance of the control systems.

The sensor rings are essential for correct road-speed calculation, and they too must match the motorcycle's control systems and consequently cannot be changed.

If you decide that you would like to fit non-standard wheels to your motorcycle, it is very important to consult a specialist workshop beforehand, preferably an authorised BMW Motorrad retailer. In some cases, the data programmed into the control units can be changed to suit the new wheel sizes.

190 MAINTENANCE

Removing front wheel

- Make sure the ground is level and firm and place the motor-cycle on its centre stand.

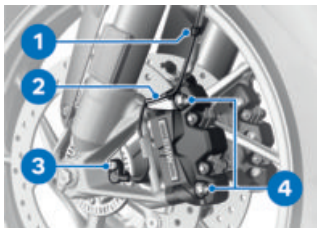

- Disengage the cable for the wheel speed sensor from holding clips **1** and **2**.
- Remove screw **3** and remove the wheel speed sensor from its bore.
- Mask off the parts of the wheel rim that could be scratched in the process of removing the brake calipers.



ATTENTION

Unwanted inward movement of the brake pads

Component damage on attempt to install the brake caliper or because brake pads have to be forced apart

- Do not operate the brakes with a brake caliper not correctly secured.

- Remove mounting bolts **4** of the left and right brake calipers.

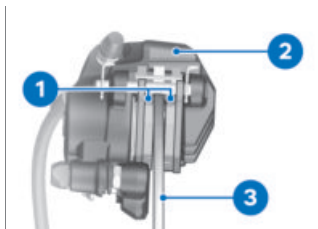

- Force brake pads **1** slightly apart by rocking brake caliper **2** back and forth against brake disc **3**.
- Carefully pull the brake calipers back and out until clear of the brake discs.
- Lift the front of the motor-cycle until the front wheel is clear of the ground, preferably using a BMW Motorrad front-wheel stand.
- Install the front-wheel stand (▮▮▮▮ 178).



- Undo right axle clamping screw **1**.

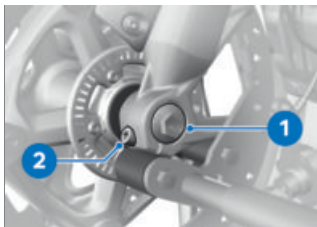

- Remove screw **1**.
- Undo left axle clamping screw **2**.
- Press quick-release axle slightly toward the inside, so as to be better able to grip it on the right-hand side.

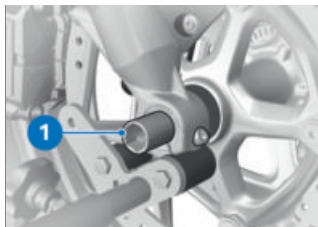

- Withdraw quick-release axle **1**, support the front wheel when doing this.
- Set down front wheel and roll forwards out of the front suspension.

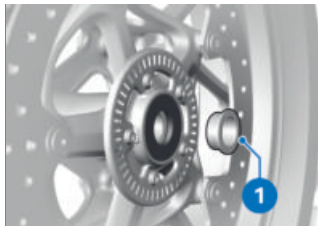

- Remove spacer bush **1** from the wheel hub.

Installing front wheel



WARNING

Use of a non-standard wheel

Malfunctions in ABS operation

- See the information on the effect of wheel size on the ABS system at the start of this chapter.

192 MAINTENANCE

ATTENTION

Tightening threaded fasteners to incorrect tightening torque

Damage, or threaded fasteners work loose

- Always have the security of the fasteners checked by a specialist workshop, preferably an authorised BMW Motorrad dealer.

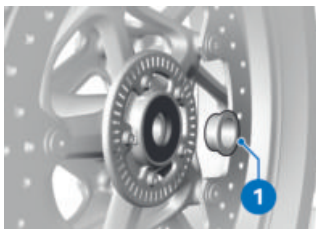

- Insert spacer bushing **1** into the wheel hub on the left side.

ATTENTION

Front wheel installed wrong way round

Risk of accident

- Note direction-of-rotation arrows on tyre or rim.
- Roll the front wheel into position in the front suspension.



- Lift the front wheel slightly and install quick-release axle **1**.
- Lubricate quick-release axle **1**.

 Lubricant

Optimoly TA

- Remove front-wheel stand and firmly compress front forks several times. Do not operate the brake lever in this process.
- Install the front-wheel stand ( 178).

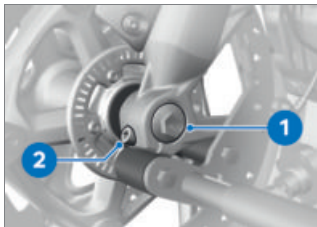

- Install screw **1** and tighten to specified torque. In this pro-

cess, counter-hold the quick-release axle on the right side.

 Quick-release axle in telescopic forks

30 Nm

- Tighten left axle clamping screw **2** to specified torque.

 Clamping screw for quick-release axle in telescopic fork

19 Nm



- Tighten right axle clamping screw **1** to specified torque.

 Clamping screw for quick-release axle in telescopic fork

19 Nm

- Remove the front-wheel stand.
- Position left and right brake calipers on the brake discs.

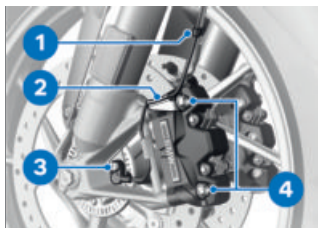

- Install securing screws **4** on left and right and tighten to specified tightening torque.

 Radial brake caliper on telescopic forks

38 Nm

- Remove the adhesive tape from the wheel rim.

WARNING

Brake pads not lying against the brake disc

Risk of accident due to delayed braking effect.

- Before driving, check that the brakes respond without delay.
- Operate the brake several times until the brake pads are bedded.
- Insert the cable for the wheel speed sensor into holding clips **1** and **2**.
- Insert the wheel speed sensor into the bore hole and install screw **3**.

194 MAINTENANCE

 Wheel-speed sensor to fork leg
Joining compound: micro-encapsulated
8 Nm

Removing rear wheel

- Make sure the ground is level and firm and place the motorcycle on its centre stand.
- Engage first gear.

CAUTION

Hot exhaust system

Risk of burn injury

- Do not touch a hot exhaust system.
-
- Allow rear silencer to cool down.



- Remove bolts **1** from the rear wheel, while supporting the wheel.
- Roll the rear wheel out toward the rear.

Installing rear wheel

WARNING

Use of a non-standard wheel

Malfunctions in ABS operation

- See the information on the effect of wheel size on the ABS system at the start of this chapter.

ATTENTION

Tightening threaded fasteners to incorrect tightening torque

Damage, or threaded fasteners work loose

- Always have the security of the fasteners checked by a specialist workshop, preferably an authorised BMW Motorrad dealer.

- Seat the rear wheel on the rear-wheel adapter.



- Install wheel bolts **1** and tighten to specified torque.

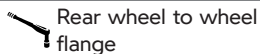

Tightening sequence: tighten in diagonally opposite sequence

60 Nm

AIR FILTER

Replace air filter element



- Remove the rider's seat (→ 124).
- Remove screws **1**, **2** and **3**.

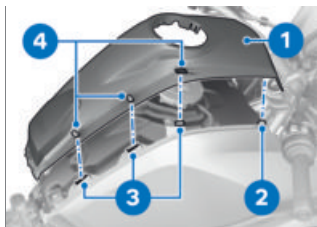

- When removing, note retaining lugs **2** and disengage holders **4** from retaining lugs **3**.
- Remove centre trim panel **1**.

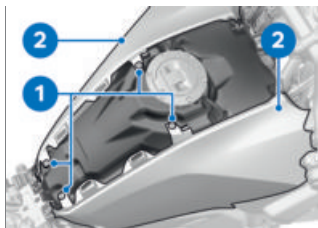

- Remove screws **1**.
- Undo cover **2** on both sides.

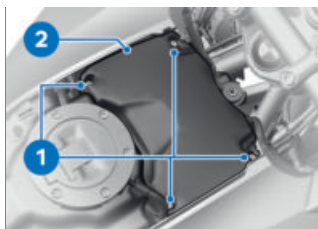

- Remove screws **1**.
- Remove air filter cover **2**.



- Remove frame **3**.
- Remove air filter insert **4**.

196 MAINTENANCE

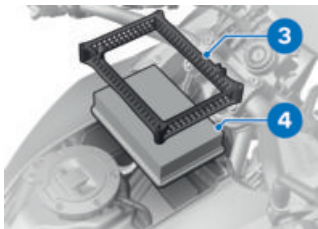

- Clean air filter insert **4** or replace it if necessary.
- Insert air filter insert **4** and frame **3**.

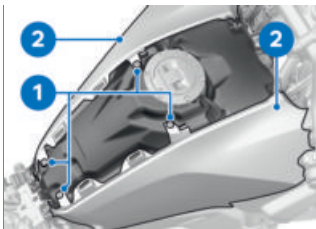

- Position cover **2** on both sides.
- Install screws (short collar) **1**.

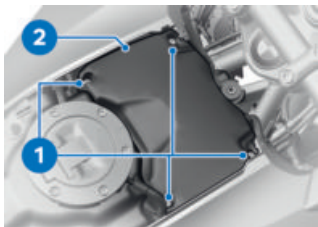

- Install air filter cover **2**.
- Install screws **1**.



Air filter cover to intake air silencer

Tightening sequence: in diagonally opposite sequence

3 Nm

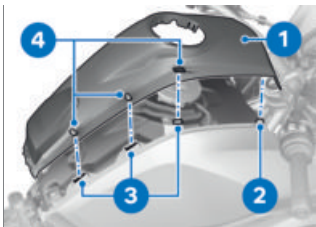

- When installing on the retaining lugs **2**, pay attention to ensure that the holder **4** engages in the retaining lugs **3**.
- Install tank cover **1**.



- Install screw **1**.



Centre tank cover on frame

8 Nm

- Install screws (short collar) **2**.
- Install screws (without collar) **3**.
- Install the rider's seat (▮▮▮▮ 125).

LIGHTING

Replacing LED light sources



WARNING

Vehicle overlooked in traffic due to failure of the lights on the vehicle

Safety risk

- Always replace a faulty bulb at the earliest possible opportunity. Consult a specialist workshop, preferably an authorised BMW Motorrad Retailer.

All light sources of the vehicle are LED light sources. The service life of the LED light sources is longer than the presumed vehicle service life. If an LED light source is faulty contact a specialist workshop, preferably an authorised BMW Motorrad retailer.

JUMP-STARTING



CAUTION

Touching live parts of the ignition system when the engine is running

Electric shock

- Do not touch parts of the ignition system when the engine is running.



ATTENTION

Excessive current flowing when the motorcycle is jump-started

Wiring smoulders/ignites or damage to the on-board electronics

- If the motorcycle has to be jump-started connect the leads to the battery terminals; never attempt to jump-start the engine by connecting leads to the on-board socket.

ATTENTION

Contact between crocodile clips of jump leads and vehicle

Risk of short-circuit

- Use jump leads fitted with fully insulated crocodile clips at both ends.

ATTENTION

Jump-starting with a voltage greater than 12 V

Damage to the on-board electronics

- Make sure that the battery of the donor vehicle has a voltage rating of 12 V.
- Make sure the ground is level and firm and place the motorcycle on its stand.
- Remove the battery cover (→ 201).
- When jump-starting the engine, do not disconnect the battery from the on-board electrical system.

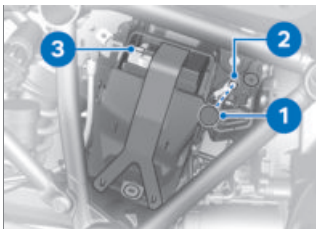

- Remove protective cap **1**.
- Use the red jump lead to connect the positive battery connection point **2** of the drained battery to the positive terminal of the donor battery.
- Then connect one end of the black jump lead to the negative terminal of the donor battery, and the other end to negative terminal **3** of the discharged battery.
- Run the engine of the donor vehicle during jump-starting.
- Start the engine of the vehicle with the discharged battery in the usual way; if the engine does not start, wait a few minutes before repeating the attempt in order to protect the starter motor and the donor battery.



Do not use proprietary start-assist sprays or other products to start the engine.

- Allow both engines to idle for a few minutes before disconnecting the jump leads.
- Disconnect the jump lead from the negative terminals first, then disconnect the second lead from the positive terminals.
- Install the protective cap.
- Installing the battery cover (▶▶▶ 203).

BATTERY

Maintenance instructions

Correct upkeep, recharging and storage will prolong the life of the battery and are essential if warranty claims are to be considered.

Compliance with the points below is important in order to maximise battery life:

- Keep the surface of the battery clean and dry.
- Do not open the battery.
- Do not top up with water.
- Be sure to read and comply with the instructions for charging the battery on the following pages.
- Do not turn the battery upside down.



ATTENTION

On-board electronics (e.g. clock) draining connected battery

Battery is deep-discharged; this voids the guarantee

- Connect a float charger to the battery if the motorcycle is to remain out of use for more than four weeks.



BMW Motorrad has developed a float charger specially designed for compatibility with the electronics of your motorcycle. Using this charger, you can keep the battery charged during long periods of disuse, without having to disconnect the battery from the motorcycle's on-board systems. You can obtain additional information from your authorised BMW Motorrad dealer.

200 MAINTENANCE

Charge battery when connected

ATTENTION

Charging the battery that is connected to the vehicle via the battery terminals

Damage to the on-board electronics

- Disconnect the battery at the battery terminals before charging.

ATTENTION

Recharging a fully discharged battery via the power socket or extra socket

Damage to the vehicle electronics

- If a battery has discharged to the extent that it is completely flat (battery voltage less than 12 V, indicator lights and multifunction display remain off when the ignition is switched on) always charge the **disconnected** battery with the charger connected directly to the battery terminals.

ATTENTION

Unsuitable chargers connected to a socket

Damage to charger and vehicle electronics

- Use suitable BMW chargers. The suitable charger is available from your authorised BMW Motorrad dealer.

- Charge via the charging socket, with the battery connected to the motorcycle's on-board electrical system.

 The motorcycle's on-board electronics know when the battery is fully charged. The on-board socket is switched off when this happens.

- Comply with the operating instructions of the charger.

 If you are unable to charge the battery through the on-board socket, you may be using a charger that is not compatible with your motorcycle's electronics. In this case, directly charge the battery at the terminals of the battery that has been disconnected from the vehicle.

Charging battery when disconnected

- Charge the battery using a suitable charger.
- Comply with the operating instructions of the charger.
- Once the battery is fully charged, disconnect the charger's terminal clips from the battery terminals.

 The battery has to be recharged at regular intervals in the course of a lengthy period of disuse. See the instructions for caring for your battery. Always fully recharge the battery before restoring it to use.

Removing battery

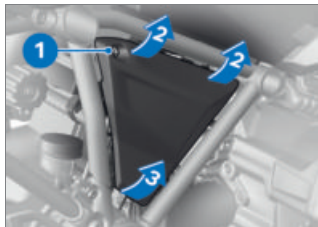

- Switch off the ignition.
- Remove screw **1**.
- Pull the battery cover slightly forward at the top at positions **2**.
- In order not to damage the battery cover or the mounting,

work the battery cover up at position **3** to remove.

- with anti-theft alarm (DWA)^{OE}
- If applicable, switch off the anti-theft alarm.◁

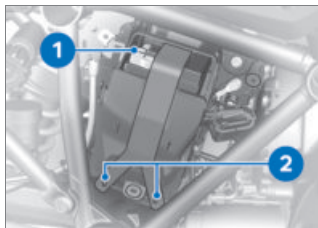

- Disconnect battery earth lead **1** and disengage rubber strap **2**.



- Pull retaining panel in position **1** outwards and remove in an upward direction.
- Slightly lift the battery and ease it clear of the holder until the battery positive terminal is accessible.

202 MAINTENANCE



- Disconnect battery negative lead **1** and remove the battery.

Installing battery

 The fuse for the alternator regulator can blow if the 12 V battery is installed incorrectly or if the terminals are swapped (e.g. when using a starting aid).



- Secure positive battery cable **1**.
- Push battery into the mounting.

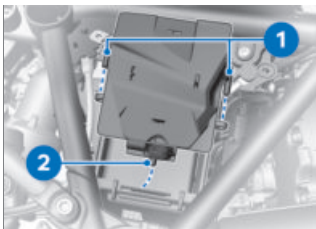

- First insert retaining plate into the mountings **1** and then push under the battery in position **2**.

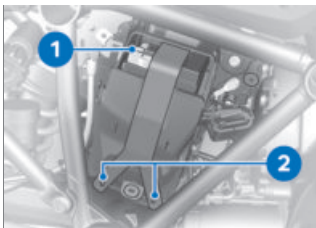

- Secure negative battery cable **1**.
- Secure the battery with rubber strap **2**.

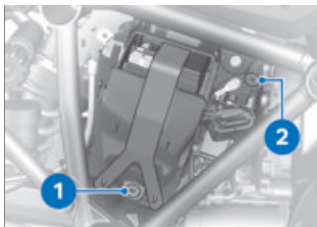

- Place battery cover into the mounting **1** and press into the mounting **2**.

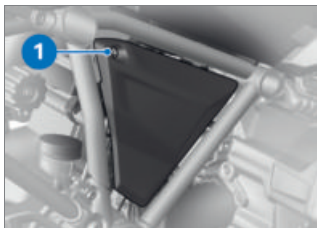

- Install screw **1**.
- Set the clock (▣▣▣▶ 103).
- Set the date (▣▣▣▶ 102).

FUSES

Replacing fuses

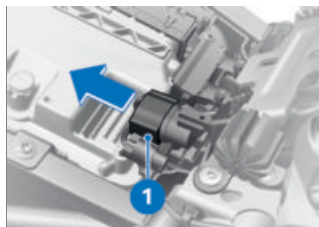

- Switch off the ignition.
- Remove the rider's seat (▣▣▣▶ 124).
- Disconnect connector **1**.

ATTENTION

Jumping of blown fuses

Risk of short-circuit and fire

- Never attempt to jumper a blown fuse.
 - Always replace a defective fuse with a new fuse of the same amperage.
- Replace faulty fuse in accordance with the fuse allocation diagram.
-  If fuse defects recur frequently have the electric circuits checked by a specialist workshop, preferably an authorised BMW Motorrad dealer.
- Install plug **1**.
 - Install the rider's seat (▣▣▣▶ 125).

204 MAINTENANCE

Fuse assignment

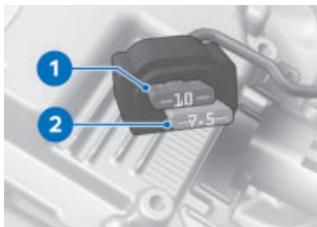

- 1** 10 A
 - Instrument cluster
 - Anti-theft alarm (DWA)
 - Ignition switch
 - Socket for onboard diagnosis
 - Coil, isolating relay
- 2** 7.5 A
 - Multifunction switch, left
 - Tyre pressure control (RDC)
 - Sensor box
 - Seat heating

Fuse for the alternator regulator



- 1** 50 A
 - Alternator regulator

 Have the fuse replaced by a specialist workshop, preferably an authorised BMW Motorrad retailer.

DIAGNOSTIC CONNECTOR

Disengaging diagnostic socket



CAUTION

Incorrect procedure followed when loosening the diagnostic connector for the on-board diagnosis

Motorcycle experiences malfunctions

- Only have the diagnostic connector loosened by a specialist workshop or other authorised persons during your next BMW Service appointment.
 - Have the work performed by appropriately trained staff.
 - Refer to the vehicle manufacturer specifications.
- Remove the battery cover (→ 201).

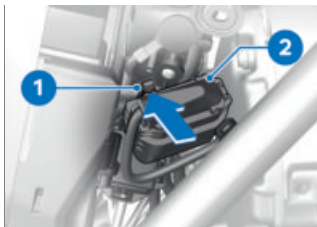

- Press hook **1** and pull diagnostic socket **2** up to remove.

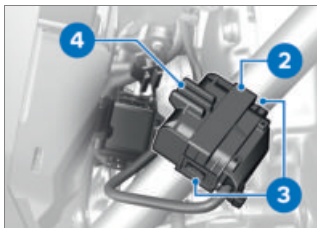

- Press locks **3** on both sides.
 - Disengage diagnostic socket **2** from holder **4**.
- » The interface to the diagnosis and information system can be connected to the diagnostic connector **2**.

Securing diagnostic socket

- Disconnect the interface for the diagnosis and information system.

206 MAINTENANCE

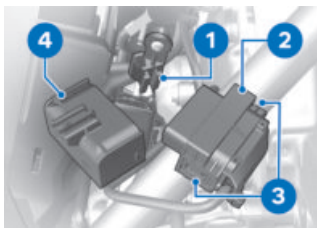

- Insert diagnostic socket **2** into holder **4**.
» Locks **3** engage on both sides.
- Seat bracket **4** on mounting **1**.



- Make sure that hook **5** engages.
- Installing the battery cover (▮▮▮ 203).

ACCESSORIES

10

GENERAL INSTRUCTIONS	210
POWER SOCKETS	210
USB CHARGING SOCKET	211
CASES	212
TOPCASE	215
NAVIGATION SYSTEM	220

GENERAL INSTRUCTIONS



CAUTION

Use of other-make products

Safety risk

- BMW Motorrad cannot examine or test each product of outside origin to ensure that it can be used on or in connection with BMW vehicles without constituting a safety hazard. Country-specific official authorisation does not suffice as assurance. Tests conducted by these instances cannot make provision for all operating conditions experienced by BMW vehicles and, consequently, they are not sufficient in some circumstances.
- Use only parts and accessories approved by BMW for your vehicle.

The components and accessory products have been thoroughly checked by BMW for safety, function and suitability. BMW therefore takes responsibility for the products. BMW does not accept liability for unauthorised parts and accessory products of any kind. Legal provisions must be taken into account when any changes

are made. Please refer to the road traffic licensing regulations (in Germany StVZO) for your country.

Your BMW Motorrad Retailer offers you qualified advice when choosing original BMW components, accessories and other products.

To find out more about accessories, go to:

bmw-motorrad.com/equipment

POWER SOCKETS

Connection of electrical devices

–You can start using electrical devices connected to the motorcycle's sockets only when the ignition is switched on.

Cable routing

- The cables from the power sockets to the auxiliary devices must be routed in such a way that they do not impede the rider.
- The cable routing should not restrict the steering angle or obstruct handling.
- The cables must not be trapped.

Automatic shutdown

- The sockets will be automatically switched off during the start procedure.
- The power supply to the sockets is switched off no more than 15 minutes after the ignition is switched off, in order to prevent overloading of the on-board electrics. Low-wattage electrical accessories might not be recognised by the vehicle's electronics. In such cases, power sockets are switched off very shortly after the ignition is turned off.
- If the battery charge state is too low to maintain the motorcycle's start capability, the power sockets are switched off.
- The power sockets are also switched off when the maximum load capability as stated in the technical data is exceeded.

USB CHARGING SOCKET

Notes on use:

Charge current

This is a 5 V USB charging interface that provides a maximum charge current of 2.4 A.

Automatic shutdown

- The USB charging sockets are shut down automatically under the following circumstances:
- If battery charge state is too low, to maintain the motorcycle's start capability.
 - If the maximum load capacity as stated in the technical data is exceeded.
 - During the starting operation.

Connection of electrical devices

You can start using electrical devices connected to the USB charging sockets only when the ignition is switched on. The power supply to the sockets is switched off no more than 15 minutes after the ignition is switched off, in order to prevent overloading of the on-board electrics.

While riding in the rain, you should disconnect the device from the interface in order to protect against damage.

To prevent dirtying, keep the protective cover closed when no device is connected.

Cable routing

Note the following with regard to the routing of cables from USB charging sockets to items of electronic equipment:

212 ACCESSORIES

- Make sure that cables do not impede the rider.
- Make sure that cables do not restrict the steering angle or obstruct handling.
- Make sure that cables cannot be trapped.

CASES

-with case^{OA}

Opening cases

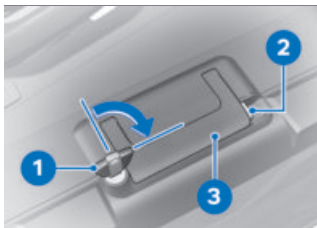

- Turn key **1** clockwise.
- Press and hold down yellow latch **2** and pull out carry handle **3**.

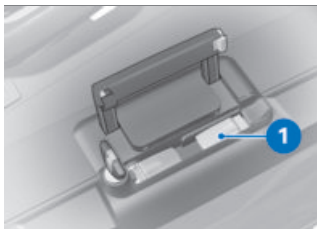

- Push yellow button **1** down, simultaneously opening the case lid.

Adjusting case volume

- Open the case and remove all its contents.

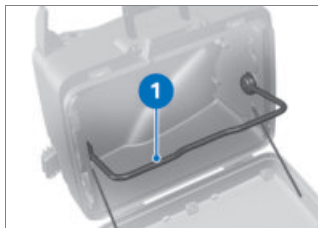

- Engage lever **1** in the upper end position to obtain the smaller volume.
- Engage lever **1** in the lower end position to obtain the larger volume.
- Close the case.

Closing cases

- Turn the lock with the key until it is at right angles to the forward direction of travel.
- Close the case lid.
- » The lid engages with an audible click.

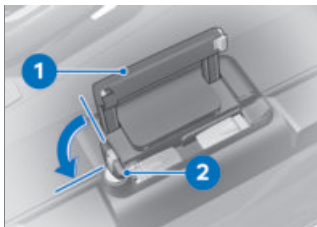

- Press and hold down yellow latch **2** and pull out carry handle **3**.



ATTENTION

Closure of carrying handle with case lock latched

Damage to locking tab

- Make sure that the case lock is at right angles to the forward direction of travel when you close the carry handle.

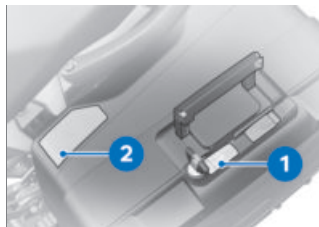

- Pull red release lever **1** up.
» Latching flap **2** pops up.
- Fully open the latching flap.
- Take a firm grip of the carry handle and lift the case out of the holder.

Installing cases

- Close carry handle **1**.
- Turn key **2** anti-clockwise and withdraw.

Removing cases

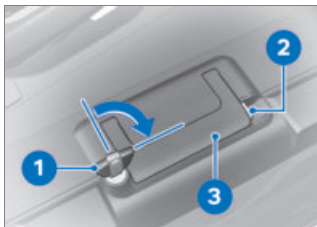

- Turn key **1** clockwise.

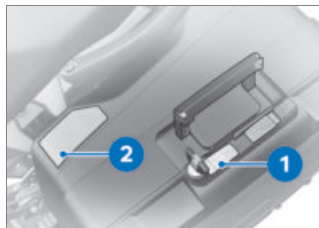

- Pull red release lever **1** up.
» Latching flap **2** pops up.
- Fully open the latching flap.

214 ACCESSORIES

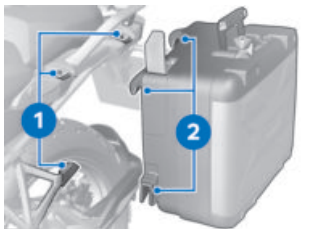

- Insert case into brackets **1** and **2** from above.

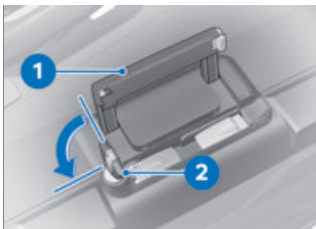

ATTENTION

Closure of carrying handle with case lock latched

Damage to locking tab

- Make sure that the case lock is at right angles to the forward direction of travel when you close the carry handle.

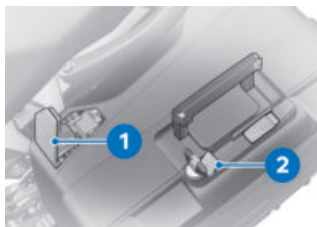

- Push locking flap **1** down until you feel some resistance.
- Then push locking flap and red release lever **2** down simultaneously.
- » The latching flap engages.



- Close carry handle **1**.
- Turn key **2** anti-clockwise and withdraw.

Maximum payload and maximum speed

Note the maximum permissible payload and the speed limit for riding with cases fitted, as stated on the label inside the case.

Contact your authorised BMW Motorrad Retailer if you cannot find your combination of vehicle and cases on the label.

The values for the combination described here are as follows:

	Maximum permissible speed for riding with Vario cases fitted to the motorcycle
	max 180 km/h
	Payload per Vario case
	max 10 kg

TOPCASE

Opening topcase

–with topcase^{OA}

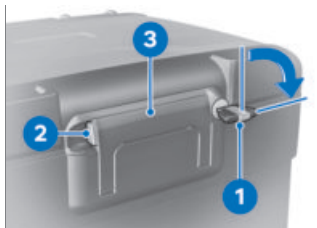

- Turn key **1** clockwise.
- Press and hold down yellow latch **2** and pull out carry handle **3**.

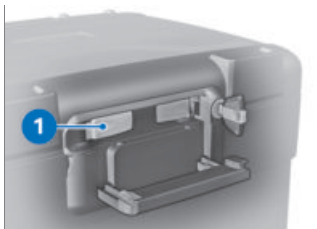

- Push yellow button **1** forwards, simultaneously opening the topcase lid.

Adjusting topcase volume

–with topcase^{OA}

- Open the topcase and remove all its contents.



- Engage lever **1** in the forwards end position to obtain the larger volume.
- Engage lever **1** in the rearwards end position to obtain the smaller volume.
- Close the topcase.

216 ACCESSORIES

Closing topcase

–with topcase^{OA}

- Press down firmly on the topcase lid to close.

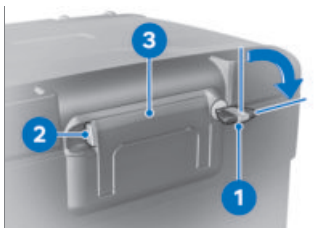
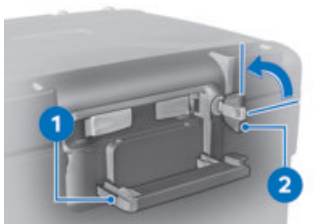

- Turn key **1** clockwise.
- Press and hold down yellow latch **2** and pull out carry handle **3**.



ATTENTION

Closure of carrying handle with case lock latched

Damage to locking tab

- Make sure that the topcase lock is vertical when you close the carry handle.
- Close carry handle **1**.
 - » The handle engages with an audible click.
- Turn key **2** anti-clockwise and withdraw.

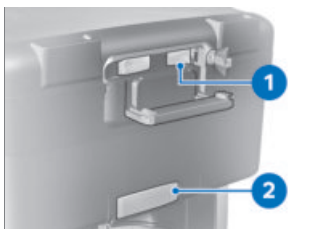

- Pull red lever **1** to the rear.
 - » Latching flap **2** pops up.
- Fully open the latching flap.
- Take a firm grip of the handle and lift the topcase out of the holder.

Removing topcase

–with topcase^{OA}

Installing topcase

–with topcase^{OA}



- Pull red lever **1** to the rear.
» Latching flap **2** pops up.
- Fully open the latching flap.



- Push locking flap **1** forwards until you feel some resistance.
- Then push locking flap and red release lever **2** forwards simultaneously.
» The locking flap engages.

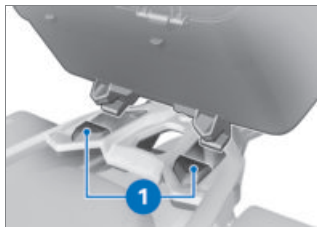

- Engage the topcase in front holders **1** of the topcase carrier plate.
- Press the rear of the topcase on to the topcase carrier plate.

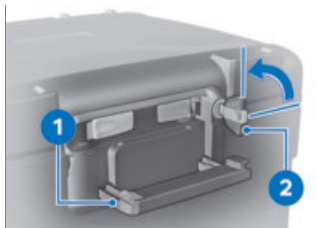

ATTENTION

Closure of carrying handle with case lock latched

Damage to locking tab

- Make sure that the topcase lock is vertical when you close the carry handle.

- Close carry handle **1**.
» The handle engages with an audible click.

218 ACCESSORIES

- Turn key **2** anti-clockwise and withdraw.

Maximum payload and maximum speed

—with topcase^{OA}

Note the maximum permissible payload and the speed limit for riding with topcase fitted, as stated on the label inside the topcase.

Contact your authorised BMW Motorrad dealer if you cannot find your combination of vehicle and topcase on the label.

The values for the combination described here are as follows:

	Maximum speed for riding with a laden Vario topcase
--	---

max 180 km/h

	Payload of Vario topcase
--	--------------------------

max 5 kg

Installing topcase

—with topcase 2, large, 50 l^{OA}

WARNING

Topcase not properly secured

Driving safety is impaired

- The topcase must not wobble and must be secured free from play.



- Pull carry handle **1** up as far as it will go.



- Hook the topcase into position on luggage carrier **1**. Make sure that hooks **2** are securely seated in keepers **3**.
- Push the carry handle down until it engages.



- Turn the key in the topcase lock to position **1** and remove the key.

	Maximum speed for riding with Top- case 2 large, 50 l
---	---

max 180 km/h

	Payload of Top- case 2 large, 50 l
---	---------------------------------------

max 5 kg

- Do not exceed the values for maximum speed and payload.

Opening topcase

–with topcase 2, large, 50 l^{OA}



- Turn the key in the topcase lock to position **1**.

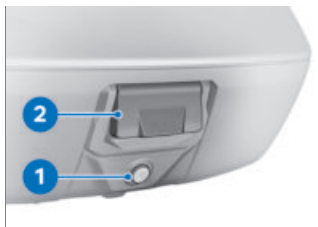

- Push lock barrel **1** forward.
» Release lever **2** pops up.
- Pull the release lever all the way up.
» The lid of the topcase opens.

Closing topcase

–with topcase 2, large, 50 l^{OA}



- Pull release lever **1** all the way up.
- Close the lid of the topcase and hold it down. Check that nothing is trapped between the lid and the case.

 The topcase can also be closed when the lock is in the **LOCK** position. In this case, make sure that the key is not left inside the topcase.

220 ACCESSORIES



- Push release lever **1** down until it engages.
- Turn key **2** in the topcase lock to the **LOCK** position and remove the key from the lock.

Removing topcase

–with topcase 2, large, 50 l^{OA}



- Turn the key in the topcase lock to position **1**.
» The handle pops out.





- Pull carry handle **1** up as far as it will go.
- Lift the topcase at the rear and remove it from the luggage carrier.

NAVIGATION SYSTEM

–with preparation for navigation system^{OE}

Securing navigation device

 Navigation preparation is suitable from BMW Motorrad Navigator IV.

 The latching system of the Mount Cradle is not designed to protect against theft.

Always remove the navigation system and stow it away safely as soon as you finish your ride.

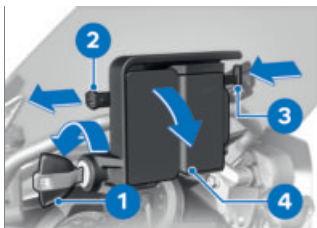

- Turn ignition key **1** counter-clockwise.
- Pull the lock retainer **2** to the **left**.
- Press the lock **3** in.
- » The Mount Cradle is unlocked and cover **4** can be pivoted forward and removed.

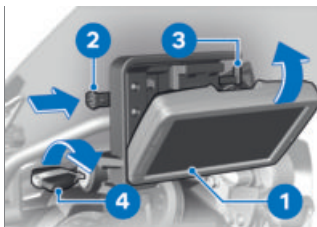

- Insert navigation device **1** at bottom and pivot it toward the rear.
- » The navigation device engages with an audible click.
- Push the lock retainer **2** all the way to the **right**.
- » Lock **3** is locked.
- Turn ignition key **4** clockwise.

» The navigation device is secured and the ignition key can be removed.

Removing navigation device and installing cover

ATTENTION

Dust and dirt on the Mount Cradle contacts

- Damaged contacts
- Always reinstall the cover as soon as you finish your ride.

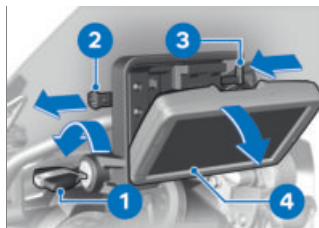

- Turn ignition key **1** anti-clockwise.
- Pull the lock retainer **2** all the way to the **left**.
- » Lock **3** is unlocked.
- Push lock **3** all the way to the **left**.
- » The navigation device **4** is unlocked.
- Tilt the navigation device **4** downwards and remove.

222 ACCESSORIES

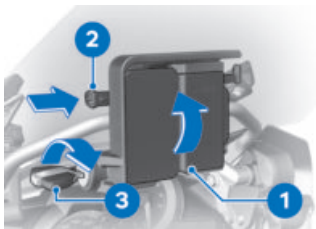

- Insert cover **1** in the lower section and swing to the top with a rotational movement.
» The cover engages with an audible click.
- Push lock retainer **2** to the **right**.
- Turn ignition key **3** clockwise.
» The cover **1** is secured.

Operating navigation system

 The description below is based on the BMW Motorrad Navigator V and the BMW Motorrad Navigator VI. The BMW Motorrad Navigator IV does not support all the options described here.

 Only the latest version of the BMW Motorrad communication system is supported. A software update of the BMW Motorrad communication system may be necessary. If this is the case, consult your authorised BMW Motorrad dealer.

If the BMW Motorrad Navigator is installed and the operating focus is switched to the Navigator ( 99), some of its functions can be operated without the rider removing a hand from the handlebars.

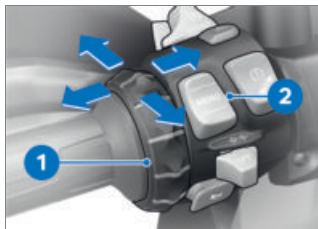

The navigation system is operated using Multi-Controller **1** and MENU rocker button **2**.

Turning Multi-Controller 1 up and down

On the Compass and Media-player pages: increase or decrease the volume of a Bluetooth-connected BMW Motorrad communication system.

In the BMW special menu: select menu item.

Short-tilting Multi-Controller 1 to the left and right

Switch between the main pages of the Navigator:

- Map view
- Compass
- Mediaplayer
- BMW special menu
- My Motorcycle page

Long-tilting Multi-Controller 1 to the left and right

Activate certain functions on the Navigator display. An arrow to the right or to the left above the corresponding button area on the display indicates a function that can be activated in this way.



Long-push to the right to activate this function.



Long-push to the left to activate this function.

Pressing bottom section of MENU rocker button 2

Switch operating focus to Pure Ride view.

In detail, the following functions can be controlled:

Map view

- Turn up: zoom in.
- Turn down: zoom out.

Compass page

- Turning increases or decreases the volume of a BMW Motorrad communication system connected via Bluetooth.

BMW special menu

- Speak: repeat most recent navigation announcement.
- Waypoint: save current location as a favourite.
- Home: starts navigation to home address (greyed if no home address has been defined).
- Mute: switch automatic navigation announcements off or on (off: a crossed-out lips symbol appears in the top line of the display). "Speak" will still activate navigation announcements. All other acoustic outputs remain switched on.
- Switch off display: deactivate the display.
- Dial home number: dials the home phone number saved in the Navigator (not shown unless a communication system and a telephone are connected).
- Diversion: activates the diversion function (not shown unless a route is active).
- Skip: skips the next waypoint (not shown unless the route has waypoints).

224 ACCESSORIES

My Motorcycle

- Turn: changes the number of data shown.
- Touch a data field on the display to open the menu for selecting data.
- The values available for selection depend on the optional extras installed on the vehicle.

Medioplayer

- Long-push to the left: play preceding track.
- Long-push to the right: play next track.
- Turning increases or decreases the volume of a BMW Motorrad communication system connected via Bluetooth.

 The Medioplayer function is only available when a Bluetooth device complying with the A2DP standard is used, for example a BMW Motorrad communication system.

Indicator and warning messages



Indicator and warning messages from the motorcycle are indicated by an appropriate symbol **1** which appears at the top left in the map view.

 If a BMW Motorrad communication system is connected, warnings are accompanied by an acoustic signal.

If there are two or more active warnings the number appears below the warning triangle. Touching the warning triangle when more than one warning is active opens a list of all the warnings. Additional information appears as soon as a message is selected.

 Detailed information cannot be displayed for all warnings.

Special functions

Integration of the BMW Motorrad Navigator can result in deviations from the descriptions in the operating instructions for the Navigator.

Fuel reserve warning

The settings for the fuel gauge are not available as the reserve warning is transmitted from the vehicle to the Navigator. Touch the message when it is active to view the locations of the nearest filling stations.

Date and time display

The Navigator sends the time and date to the motorcycle. To accept the time in the TFT display, the *GPS synchronisation* function must also be activated in the menu *Settings, System settings, Date and time*.

Security settings

The BMW Motorrad Navigator V and the BMW Motorrad Navigator VI can be secured against unauthorised use with a four-digit PIN (Garmin Lock). If this function is activated while the Navigator is installed in the vehicle and the ignition is switched on, you will be asked whether you want to add this

vehicle to the list of secured vehicles. If you answer "Yes" at this prompt, the Navigator saves the VIN of this vehicle in its internal memory. A maximum of five VINs can be saved in this way. It is then no longer necessary to enter the PIN when the Navigator is switched on by ignition ON on any of these vehicles. If the Navigator is removed from the vehicle while switched on, a security prompt is issued asking for the PIN to be entered.

Screen brightness

In the installed condition, the screen brightness is specified by the motorcycle. Manual input is not necessary. Automatic setting can be switched off in the display settings for the Navigator if desired.

CARE

11

CARE PRODUCTS	228
WASHING THE VEHICLE	228
CLEANING EASILY DAMAGED COMPONENTS	229
CARE OF PAINTWORK	230
PAINTWORK PRESERVATION	231
LAYING UP THE MOTORCYCLE	231
RESTORING MOTORCYCLE TO USE	231

CARE PRODUCTS

BMW Motorrad recommends that you use the cleaning and care products you can obtain from your authorised BMW Motorrad Retailer. The substances in BMW Care Products have been tested in laboratories and in practice; they provide optimised care and protection for the materials used in your vehicle.



ATTENTION

Use of unsuitable cleaning and care products

Damage to vehicle parts

- Do not use solvents such as cellulose thinners, cold cleaners, fuel or the like, and do not use cleaning products that contain alcohol.



ATTENTION

Use of strongly acidic or strongly alkaline cleaning agents

Damage to vehicle parts

- Dilute in accordance with the dilution ratio stated on the packaging of the cleaning agent.
- Do not use strongly acidic or strongly alkaline cleaning agents.

WASHING THE VEHICLE

BMW Motorrad recommends that you use BMW insect remover to soften and wash off insects and stubborn dirt on painted parts prior to washing the vehicle.

To prevent stains, do not wash the motorcycle immediately after it has been exposed to strong sunlight and do not wash it in the sun.

Remove dirt from the fork legs at regular intervals.

Make sure that the vehicle is washed frequently, especially during the winter months.

To remove road salt, clean the motorcycle with cold water immediately after every trip.

**WARNING****Wet brake discs and brake pads after vehicle wash, after riding through water and in rainy conditions**

Diminished braking effect, risk of accident

- Apply the brakes in good time to allow the friction and heat to dry the brake discs and brake pads.

**ATTENTION****Effect of road salt intensified by warm water**

Corrosion

- Use only cold water to wash off road salt.

**ATTENTION****Damage due to high water pressure from high pressure cleaners or steam cleaners**

Corrosion or short circuit, damage to labels, seals, hydraulic brake system, electrical system and the motorcycle seat

- Exercise restraint when using a steam jet or high pressure cleaning equipment.

CLEANING EASILY DAMAGED COMPONENTS**Plastics****ATTENTION****Use of unsuitable cleaning agents**

Damage to plastic surfaces

- Do not use cleaning agents that contain alcohol, solvents or abrasives.
- Do not use insect-remover pads or cleaning pads with hard, scouring surfaces.

Body panels

Clean trim panel components with water and BMW Motorrad solvent cleaner.

Plastic windscreens and headlight lenses

Remove dirt and insects with a soft sponge and generous amounts of water.



Soften stubborn dirt and insects by covering the affected areas with a wet cloth.



Clean with water and sponge only.



Do not use any chemical cleaning agents.

230 CARE

TFT display

Clean the TFT display with warm water and washing-up liquid. Then dry it with a clean cloth, e.g. a paper towel.

Chrome

Carefully clean chrome parts with plenty of water and motorcycle cleaner from the BMW Motorrad Care Products range. This is particularly important to counter the effects of road salt. For an additional treatment, use BMW Motorrad metal polish.

Radiator

Clean the radiator regularly to prevent overheating of the engine due to inadequate cooling. For example, use a garden hose with low water pressure.



ATTENTION

Bending of radiator fins

Damage to radiator fins

- Take care not to bend the radiator fins when cleaning.

Rubber

Treat rubber components with water or BMW rubber-care products.



ATTENTION

Application of silicone sprays to rubber seals

Damage to the rubber seals

- Do not use silicone sprays or care products that contain silicon.

CARE OF PAINTWORK

Washing the vehicle regularly will help counteract the long-term effects of substances that can damage the paint, especially if your vehicle is ridden in areas with high air pollution or natural sources of dirt, for example tree resin or pollen. Remove particularly aggressive substances immediately, however, as otherwise the paint can be affected or become discoloured. Substances of this nature include spilt fuel, oil, grease, brake fluid and bird droppings. For this, we recommend BMW Motorrad solvent cleaner followed by BMW Motorrad gloss polish for preservation. Marks on the paintwork are particularly easy to see after the motorcycle has been washed. Remove stains of this kind at the earliest possible

opportunity, using benzine or petroleum spirit on a clean cloth or ball of cotton wool. BMW Motorrad recommends using BMW tar remover for removing specks of tar. Then apply preserving agent to the areas treated in this way.

PAINTWORK PRESERVATION

If water no longer rolls off the paint, the paint must be preserved.

For paint preservation, BMW Motorrad recommends the use of BMW Motorrad gloss polish or agents containing carnauba wax or synthetic wax.

LAYING UP THE MOTORCYCLE

- Clean the motorcycle.
- Fill the motorcycle's fuel tank and, if necessary, pour fuel additive into the tank. BMW Motorrad recommends using ADVANTEC Protect Original BMW Fuel Additive to prevent fuel ageing effects.
- Removing battery (➡ 201).
- Spray the brake and clutch lever pivots and the main and side stand pivots with a suitable lubricant.
- Preserve bright metal and chrome-plated parts with an acid-free grease (e.g. Vaseline).
- Park the motorcycle in a dry room so that no load applies to either wheel (preferably using the front-wheel and rear-wheel stand available from BMW Motorrad).

RESTORING MOTORCYCLE TO USE

- Remove the protective wax coating.
- Clean the motorcycle.
- Install the battery.
- Checklist (➡ 135).

TECHNICAL DATA

12

TROUBLESHOOTING CHART	234
SCREW CONNECTIONS	236
FUEL	238
ENGINE OIL	239
ENGINE	239
CLUTCH	240
TRANSMISSION	240
REAR-WHEEL DRIVE	241
FRAME	241
CHASSIS AND SUSPENSION	242
BRAKES	243
WHEELS AND TYRES	244
ELECTRICAL SYSTEM	245
ANTI-THEFT ALARM	246
DIMENSIONS	246
WEIGHTS	249
RIDING SPECIFICATIONS	249

234 TECHNICAL DATA

TROUBLESHOOTING CHART

The engine does not start.

Possible cause	Rectification
Side stand extended and gear engaged	Retract the side stand.
Gear engaged and clutch not disengaged	Select neutral or pull the clutch lever.
No fuel in tank	Refuelling (➡ 146).
Battery flat	Charge battery when connected (➡ 200).
Overheating protection for starter motor has been activated. Starter motor can only be operated for a limited period of time.	Allow the starter motor to cool down for approx. 1 minute before using it again.

The Bluetooth connection is not established.

Possible cause	Rectification
The steps required for pairing were not carried out.	Check the necessary steps for pairing in the operating instructions for the communication system.
The communication system was not connected automatically despite successful pairing.	Switch off the helmet's communication system and reconnect it after a minute or two.
Too many Bluetooth devices are saved on the helmet.	All pairing entries on the helmet are deleted (see the communication system operating instructions).
There are other vehicles with Bluetooth-capable devices in the vicinity.	Avoid simultaneously pairing with more vehicles.

Bluetooth connection is interrupted.

Possible cause	Rectification
The Bluetooth connection to the mobile end device is interrupted.	Switch off energy saving mode.
The Bluetooth connection to the helmet is interrupted.	Switch off the helmet's communication system and reconnect it after a minute or two.
The volume in the helmet cannot be adjusted.	Switch off the helmet's communication system and reconnect it after a minute or two.

The telephone book is not displayed in the TFT display.

Possible cause	Rectification
The phone book was not transmitted to the vehicle.	When pairing the mobile end device, confirm transmission of the phone data (☰▶ 113).

Active route guidance is not displayed in the TFT display.

Possible cause	Rectification
Navigation from the BMW Motorrad Connected App was not transmitted.	The BMW Motorrad Connected App is opened on the connected mobile end device prior to departure.
The route guidance cannot be started.	Secure the mobile device's data connection and check the map data on the mobile end device.

236 TECHNICAL DATA

SCREW CONNECTIONS

Front wheel	Value	Valid
Quick-release axle in telescopic forks		
M12 x 20	30 Nm	
Clamping screw for quick-release axle in telescopic fork		
M8 x 35	19 Nm	
Radial brake caliper on telescopic forks		
M10 x 65	38 Nm	
Wheel-speed sensor to fork leg		
M6 x 16 Micro-encapsulated	8 Nm	

Rear wheel	Value	Valid
Rear wheel to wheel flange		
M10 x 1.25 x 40	Tightening sequence: tighten in diagonally opposite sequence 60 Nm	

Mirrors	Value	Valid
Mirror (locknut) to adapter		
M10 x 1.25	Left-hand thread, 22 Nm	
Adapter to clamping block		
M10 x 14 - 4.8	25 Nm	

Mirrors	Value	Valid
Mirror on handlebars		
M10 x 30	25 Nm	
M10 x 50	25 Nm	-with hand protector ^{OE}

Gearshift lever	Value	Valid
Peg to gearshift lever		
M6 x 20 micro-encapsulated	10 Nm	





Footbrake lever	Value	Valid
Peg to footbrake lever		
M6 x 20 micro-encapsulated	10 Nm	

Footrests	Value	Valid
Clamping block on footrest hinge		
M8 x 25	20 Nm	
Footrest on clamping block		
M6 x 20 / M6 x 12	10 Nm	

Handlebars	Value	Valid
Clamping block (handlebar clamp) to fork bridge		
M8 x 35	Tightening sequence: in the forward direction of travel, tighten until seated	
	19 Nm	

238 TECHNICAL DATA

FUEL

Recommended fuel grade	 Super unleaded (max 15 % ethanol, E10/E15)  95 ROZ/RON 90 AKI
Alternative fuel grade	 Normal unleaded (power- and consumption-related restrictions.) (max 15 % ethanol, E10/E15)  91 ROZ/RON 87 AKI
Usable fuel capacity	approx. 20 l
Reserve fuel	approx. 4 l
Fuel consumption	4.75 l/100 km, in accordance with WMTC
CO2 emission	110 g/km, following world-wide harmonised motorcycle test cycle (WMTC)
–with power reduction ^{OE}	113 g/km, following world-wide harmonised motorcycle test cycle (WMTC)
Exhaust emissions standard	EU5

ENGINE OIL

Engine oil, capacity	max 4 l, with filter change
Specification	SAE 5W-40, API SL / JASO MA2, Additives (e.g. molybdenum-based) are not permissible because they can attack coated components of the engine, BMW Motorrad recommends BMW Motorrad ADVANTEC Ultimate
Engine oil, quantity for topping up	max 0.8 l, Difference between MIN and MAX

BMW recommends **ADVANTEC**
ORIGINAL BMW ENGINE OIL

ENGINE

Engine number location	Crankcase, bottom right, below starter motor
Engine type	A74B12M
Engine design	Air/liquid-cooled, two-cylinder four-stroke opposed-twin engine with two overlying, spur-gear-driven camshafts, a counterbalance shaft and BMW ShiftCam variable intake camshaft control
Displacement	1254 cm ³
Cylinder bore	102.5 mm
Piston stroke	76 mm
Compression ratio	12.5:1
Nominal capacity	100 kW, at engine speed: 7750 min ⁻¹
-with power reduction ^{OE}	79 kW, at engine speed: 7750 min ⁻¹

240 TECHNICAL DATA

Torque	143 Nm, at engine speed: 6250 min ⁻¹
-with power reduction ^{OE}	140 Nm, at engine speed: 5000 min ⁻¹
Maximum engine speed	max 9000 min ⁻¹
Idle speed	1050 min ⁻¹ , Engine at regular operating temperature

CLUTCH

Clutch type	Multiplate oil-bath clutch, anti- hopping
-------------	--

TRANSMISSION

Type of transmission	Claw-shift 6-speed gearbox with helical gearing
Gearbox transmission ratios	1.000 (60:60 teeth), Primary transmission ratio 1.650 (33:20 teeth), Transmis- sion input ratio 2.438 (39:16 teeth), 1st gear 1.714 (36:21 teeth), 2nd gear 1.296 (35:27 teeth), 3rd gear 1.059 (36:34 teeth), 4th gear 0.943 (33:35 teeth), 5th gear 0.848 (28:33 teeth), 6th gear 1.061 (35:33 teeth), Transmis- sion output ratio

REAR-WHEEL DRIVE

Type of final drive	Shaft drive with bevel gears
Type of rear suspension	Cast aluminium single swinging arm featuring BMW Motorrad Paralever
Gear ratio of final drive	2.91 (32/11 teeth)
Rear axle differential oil	SAE 70W-80, above 5° C and below 5° C

FRAME

Frame type	Tubular steel frame with supporting drive unit, steel pipe rear frames
Type plate location	Frame, front left at steering head
Position of the vehicle identification number	Frame, front right below steering head

242 TECHNICAL DATA

CHASSIS AND SUSPENSION

Front wheel

Type of front suspension	BMW Telelever, with anti-dive top fork bridge, leading link pivot-mounted on engine and telescopic forks, central spring strut supported by leading link and frame
Design of front wheel suspension	Central shock absorber with helical spring
-with Dynamic ESA ^{OE}	Central shock absorber complete with torsion spring and header tank, electrically adjustable decompression and compression-stage damping
Spring travel, front	190 mm, at front wheel
-with sport suspension ^{OE}	210 mm, at front wheel
-with low-slung ^{OE}	158 mm, at front wheel

Rear wheel	
Type of rear suspension	Cast aluminium single swinging arm featuring BMW Motorrad Paralever
Type of rear-wheel suspension	Central spring strut with coil spring, adjustable rebound stage damping and spring preload
-with Dynamic ESA ^{OE}	Central spring strut with coil spring and reservoir, electrically adjustable rebound-stage and compression-stage damping, electrically adjustable spring preload
Spring travel at rear wheel	200 mm, at rear wheel
-with sport suspension ^{OE}	220 mm, at rear wheel
-with low-slung ^{OE}	170 mm, at rear wheel

BRAKES

Front wheel	
Type of front brake	Twin disc brakes, floating brake discs, diameter 305 mm, 4-piston radial calipers
Brake-pad material, front	Sintered metal
Brake disc thickness, front	4.5 mm, When new min 4.0 mm, Wear limit
Play of brake controls (Front brake)	1.6...2.1 mm, on the piston

244 TECHNICAL DATA

Rear wheel	
Type of rear brake	Single-disc brake, diameter 276 mm, 2-piston floating caliper
Brake-pad material, rear	Sintered metal
Brake disc thickness, rear	5.0 mm, When new min 4.5 mm, Wear limit
Blow-by clearance of the foot-brake lever	1...1.5 mm, between the frame and the footbrake lever

WHEELS AND TYRES

Recommended tyre combinations	An overview of currently approved tyres is available from your authorised BMW Motorrad Retailer or on the Internet at bmw-motorrad.com .
Speed category, front/rear tyres	V, required at least: 240 km/h

Front wheel	
Front-wheel type	Aluminium cast wheel
–with cross-spoked wheels ^{OE}	cross-spoked wheel
Front-wheel rim size	3.00" x 19"
Tyre designation, front	120/70 R 19
Load index, front tyre	60
Permissible front-wheel imbalance	max 5 g

Rear wheel

Rear-wheel type	Aluminium cast wheel
–with cross-spoked wheels ^{OE}	cross-spoked wheel
Rear wheel rim size	4.50" x 17"
Tyre designation, rear	170/60 R 17
Load index, rear tyre	72
Permissible rear-wheel imbalance	max 45 g

Tyre pressures

Tyre pressure, front	2.5 bar, sport riding
	2.5 bar, One-up, tyre cold
	2.5 bar, Two-up mode with load, with cold tyres
Tyre pressure, rear	2.9 bar, One-up, tyre cold
	2.9 bar, Two-up mode with load, with cold tyres

ELECTRICAL SYSTEM

Electrical rating of on-board sockets	max 5 A, total for all sockets
Fuse carrier 1	10 A, Slot 1: instrument cluster, alarm system (DWA), ignition switch, socket for onboard diagnosis, coil of isolating relay 7.5 A, Slot 2: left multifunction switch, tyre pressure control (RDC), sensor box, seat heating
Fuse holder	50 A, Fuse 1: voltage regulator

246 TECHNICAL DATA

Battery

Battery type	AGM battery (Absorbent Glass Mat), maintenance-free
–with M Lightweight battery ^{OE}	Lithium-ion battery
Battery rated voltage	12 V
–with M Lightweight battery ^{OE}	12 V
Battery rated capacity	14 Ah
–with M Lightweight battery ^{OE}	10 Ah

Spark plugs

Spark plugs, manufacturer and designation	NGK LMAR8AI-10
---	----------------

Lighting

Bulb for high-beam headlight	LED
Bulbs for the low-beam headlight	LED
Bulb for parking light	LED
Bulb for tail light/brake light	LED
Bulbs for turn indicators	LED

ANTI-THEFT ALARM

Activation time on arming	approx. 30 s
Alarm duration	approx. 26 s
Battery type	CR 123 A

DIMENSIONS

Length of motorcycle	2207 mm, over spray guard
----------------------	---------------------------

Height of motorcycle	1430...1490 mm, over wind-screen, at DIN unladen weight
-with Rallye style ^{OE} -with low-slung ^{OE} -with passenger package, low ^{OE}	1330...1380 mm, over wind-screen, at DIN unladen weight
-with Rallye style ^{OE} -with low-slung ^{OE} -with Rallye seat, low ^{OE}	1330...1380 mm, over wind-screen, at DIN unladen weight
-with Edition ^{OE} -with low-slung ^{OE} -with passenger package, low ^{OE}	1330...1380 mm, over wind-screen, at DIN unladen weight
-with Edition ^{OE} -with low-slung ^{OE} -with Rallye seat, low ^{OE}	1330...1380 mm, over wind-screen, at DIN unladen weight
-with Rallye style ^{OE} -with Rallye seat, low ^{OE}	1350...1400 mm, over wind-screen, at DIN unladen weight
-with Edition ^{OE} -with Rallye seat, low ^{OE}	1350...1400 mm, over wind-screen, at DIN unladen weight
-with Rallye style ^{OE} -with sport suspension ^{OE} -with Rallye seat, low ^{OE}	1370...1420 mm, over wind-screen, at DIN unladen weight
-with low-slung ^{OE}	1410...1470 mm, over wind-screen, at DIN unladen weight
-with Rallye style ^{OE} -with two-up riding package ^{OE} -with sport suspension ^{OE}	1450...1510 mm, over wind-screen, at DIN unladen weight
Width of motorcycle	952 mm, with mirrors
-with hand protector ^{OA}	980 mm, with hand protector
	895 mm, without mounted parts

248 TECHNICAL DATA

Height of rider's seat	850...870 mm, without rider, at DIN unladen weight
-with low-slung ^{OE} -with rider's seat, low ^{OE}	800...820 mm, without rider, at DIN unladen weight
-with low-slung ^{OE} -with rider's seat, low ^{OE} -with seat heating ^{OE}	805...825 mm, without rider, at DIN unladen weight
-with rider's seat, low ^{OE}	820...840 mm, without rider, at DIN unladen weight
-with rider's seat, low ^{OE} -with seat heating ^{OE}	825...845 mm, without rider, at DIN unladen weight
-with low-slung ^{OE}	830...850 mm, without rider, at DIN unladen weight
-with low-slung ^{OE} -with Rallye seat, low ^{OE}	840 mm, without rider, at DIN unladen weight
-with Rallye seat, low ^{OE}	860 mm, without rider, at DIN unladen weight
-with two-up riding package ^{OE} -with sport suspension ^{OE}	870...890 mm, without rider, at DIN unladen weight
-with sport suspension ^{OE} -with Rallye seat, low ^{OE}	880 mm, without rider, at DIN unladen weight
Rider's inside-leg arc, heel to heel	1870...1910 mm, without rider, at DIN unladen weight
-with low-slung ^{OE} -with rider's seat, low ^{OE}	1790...1830 mm, without rider, at DIN unladen weight
-with rider's seat, low ^{OE}	1820...1860 mm, without rider, at DIN unladen weight
-with low-slung ^{OE}	1830...1870 mm, without rider, at DIN unladen weight
-with low-slung ^{OE} -with Rallye seat, low ^{OE}	1840 mm, without rider, at DIN unladen weight

-with low-slung ^{OE} -with rider's seat, low ^{OE} -with seat heating ^{OE}	1840...1860 mm, without rider, at DIN unladen weight
-with Rallye seat, low ^{OE}	1880 mm, without rider, at DIN unladen weight
-with low-slung ^{OE} -with seat heating ^{OE}	1880...1900 mm, without rider, at DIN unladen weight
-with rider's seat, low ^{OE} -with seat heating ^{OE}	1880...1900 mm, without rider, at DIN unladen weight
-with two-up riding package ^{OE} -with sport suspension ^{OE}	1910...1950 mm, without rider, at DIN unladen weight
-with sport suspension ^{OE} -with Rallye seat, low ^{OE}	1920 mm, without rider, at DIN unladen weight
-with seat heating ^{OE}	1920...1940 mm, without rider, at DIN unladen weight

WEIGHTS

Vehicle kerb weight	249 kg, DIN unladen weight, ready for road 90 % load of fuel, without OE
Permissible gross vehicle weight	465 kg
Maximum payload	216 kg

RIDING SPECIFICATIONS

Top speed	>200 km/h
-with case ^{OA}	180 km/h
-with topcase ^{OA}	180 km/h

SERVICE

13

REPORTING SAFETY-RELEVANT DEFECTS	252
BMW MOTORRAD SERVICE	253
BMW MOTORRAD SERVICE HISTORY	253
BMW MOTORRAD MOBILITY SERVICES	254
MAINTENANCE WORK	254
BMW SERVICE	254
MAINTENANCE SCHEDULE	256
MAINTENANCE CONFIRMATIONS	257
SERVICE CONFIRMATIONS	271

REPORTING SAFETY-RELEVANT DEFECTS

—with Canada export^{NV}

If you think that your motorcycle has a fault which may cause an accident, injury or death, you must inform the NHTSA (National Highway Traffic Safety Administration) immediately and BMW of North America, LLC.

If the NHTSA receives other similar complaints, it may open an investigation. If it finds that a safety defect exists in a group of vehicles, the NHTSA may order the manufacturer to perform a recall and remedy campaign. However, the NHTSA cannot become involved in individual problems between you, your retailer, or BMW of North America, LLC.

You can contact the NHTSA by calling the Vehicle Safety hotline on 1-888-327-4236 (teletypewriter TTY for the hearing impaired: 1-800-424-9153) for free, by visiting the website at [http:// www.safercar.gov](http://www.safercar.gov) or by writing to Administrator, NHTSA, 400 Seventh Street, SW., Washington, DC 20590. Further information on vehicle safety is available at [http:// www.safercar.gov](http://www.safercar.gov).

Canadian customers who wish to report a safety-related defect to Transport Canada, Defect Investigations and Recalls can call the toll-free hotline 1-800-333-0510. You can also obtain other information about motor vehicle safety from [http:// www.tc.gc.ca/roadsafety](http://www.tc.gc.ca/roadsafety).

BMW MOTORRAD SERVICE

BMW Motorrad has an extensive network of dealerships in place to look after you and your motorcycle in more than 100 countries. Authorised BMW Motorrad dealerships have the technical information and the technical know-how to carry out reliably all maintenance and repair work on your BMW.

You can locate your nearest authorised BMW Motorrad dealership by visiting our website: bmw-motorrad.com



WARNING

Maintenance and repair work not in compliance with correct procedure

Risk of accident due to consequential damage

- BMW Motorrad recommends having work of this nature carried out on the vehicle by a specialist workshop, preferably an authorised BMW Motorrad dealer.

In order to help ensure that your BMW is always in optimum condition, BMW Motorrad recommends compliance with the maintenance intervals specified for your motorcycle.

Have all maintenance and repair work that is carried out confirmed in the "Service" chapter in this manual. For generous treatment of claims submitted after the warranty period has expired, evidence of regular maintenance is essential.

Your authorised BMW Motorrad dealer can provide information on BMW services and the work undertaken as part of each service.

BMW MOTORRAD SERVICE HISTORY

Entries

Maintenance work that has been carried out is entered in the proof of maintenance. The entries are like a Service Booklet and provide proof of regular maintenance.

When an entry is made in the electronic service booklet of the vehicle, service-relevant data is saved in the central IT

254 SERVICE

systems of BMW AG, Munich, Germany.

If there is a change in vehicle owner, the data saved in the electronic service booklet can also be viewed by the new vehicle owner. A BMW Motorrad retailer or a specialist workshop can also view data that is stored in the electronic service booklet.

Objection

The vehicle owner can object to entries being made by the BMW Motorrad retailer or a specialist workshop in the electronic service booklet along with the corresponding storage of data in the vehicle and transfer of data to the vehicle manufacturer for the period of time that they are the vehicle owner. In this instance, no entry is made in the electronic service booklet of the vehicle.

BMW MOTORRAD MOBILITY SERVICES

As owner of a new BMW motorcycle, in circumstances in which assistance is required you can benefit from the protection afforded by the various BMW Motorrad mobility services (e.g. Mobile Service,

breakdown service, vehicle recovery service).

Your authorised BMW Motorrad dealer will be happy provide information about the mobility services available to you.

MAINTENANCE WORK

BMW pre-delivery check

Your authorised BMW Motorrad retailer conducts the BMW pre-delivery check before handing over the vehicle to you.

BMW Running-in Check

The BMW running-in check has to be performed when the motorcycle has covered between 500 km and 1200 km.

BMW SERVICE

The BMW Service is carried out once a year. The scope of the service depends on the age of the vehicle and the mileage ridden. Your BMW Motorrad Retailer will confirm the service that has been carried out for you and will enter the deadline for the next service.

For riders with a high mileage it may be necessary to have a service before the specified deadline. In this case, a corresponding maximum mileage

is entered in the service confirmation. If this mileage is reached before the next service deadline, the service must be brought forward.

The Service Interval Indicator in the TFT display reminds you about one month or 1000 km in advance when the time for a service is approaching, on the basis of the programmed values.

To find out more about service, go to:

[bmw-motorrad.com/service](https://www.bmw-motorrad.com/service)

The scope of maintenance work required for your vehicle can be found in the following maintenance schedule:

256 SERVICE

MAINTENANCE SCHEDULE

	50 000 km 300 - 750 mls	10 000 km 6 000 mls	20 000 km 12 000 mls	30 000 km 18 000 mls	40 000 km 24 000 mls	50 000 km 30 000 mls	60 000 km 36 000 mls	70 000 km 42 000 mls	80 000 km 48 000 mls	90 000 km 54 000 mls	100 000 km 60 000 mls	12 months	24 months
①	X												
②												X	
③		X	X	X	X	X	X	X	X	X	X	X ^a	
④			X		X		X		X		X		X ^b
⑤			X		X		X		X		X		
⑥			X		X		X		X		X		
⑦			X		X		X		X		X		
⑧		X	X	X	X	X	X	X	X	X	X	X ^c	
⑨												X ^d	X ^d

- 1 BMW running-in check (including oil change)
- 2 BMW Service standard scope
- 3 Engine-oil change, with filter
- 4 Oil change in bevel gears rear
- 5 Check valve clearance
- 6 Replace all spark plugs
- 7 Replace air filter element
- 8 Check or replace air-filter element
- 9 Change brake fluid, entire system

- a annually or every 10000 km (whichever comes first)
- b every 2 years or every 20000 km (whichever comes first)
- c if vehicle is used off-road, annually or every 10000 km (whichever comes first)
- d for the first time after one year, then every two years

MAINTENANCE CONFIRMATIONS

BMW Service standard scope

The repair tasks in the BMW Service standard scope are listed below. The actual scope of maintenance work applicable for your vehicle may vary.

- Performing vehicle test with BMW Motorrad diagnosis system
- Visual inspection of clutch system
- Visual inspection of the brake lines, brake hoses and connections
- Checking front brake pads and brake discs for wear
- Checking brake-fluid level, front wheel brake
- Checking rear brake pads and brake disc for wear
- Checking brake-fluid level, rear wheel brake
- Checking coolant level
- Check the side stand's ease of movement
- Checking ease of movement of the centre stand
- Checking tyre pressure and tread depth
- Checking spoke tension, adjusting if necessary
- Check lighting and signalling system
- Function test, engine start suppression
- Final inspection and check for road safety
- Setting service-due date and countdown distance with BMW Motorrad diagnosis system
- Checking battery state of charge
- Confirming BMW service in on-board literature

258 SERVICE

BMW pre-delivery check
carried out

at _____

Stamp, signature

BMW Running-in Check
carried out

at _____

Odometer reading _____

Next service

at the latest

at _____

or, when reached earlier

Odometer reading _____

Stamp, signature

BMW Service

carried out

at _____

Odometer reading _____

Next service

at the latest

at _____

or, when reached earlier

Odometer reading _____

Work performed

	Yes	No
BMW Service	<input type="checkbox"/>	<input type="checkbox"/>
Oil change, engine, with filter	<input type="checkbox"/>	<input type="checkbox"/>
Oil change in rear bevel gears	<input type="checkbox"/>	<input type="checkbox"/>
Checking valve clearance	<input type="checkbox"/>	<input type="checkbox"/>
Renewing all spark plugs	<input type="checkbox"/>	<input type="checkbox"/>
Renewing air cleaner insert	<input type="checkbox"/>	<input type="checkbox"/>
Checking or replacing air filter element (for maintenance)	<input type="checkbox"/>	<input type="checkbox"/>
Change brake fluid in entire system	<input type="checkbox"/>	<input type="checkbox"/>

Notes

Stamp, signature

260 SERVICE

BMW Service

carried out

at _____

Odometer reading _____

Next service

at the latest

at _____

or, when reached earlier

Odometer reading _____

Work performed

	Yes	No
BMW Service	<input type="checkbox"/>	<input type="checkbox"/>
Oil change, engine, with filter	<input type="checkbox"/>	<input type="checkbox"/>
Oil change in rear bevel gears	<input type="checkbox"/>	<input type="checkbox"/>
Checking valve clearance	<input type="checkbox"/>	<input type="checkbox"/>
Renewing all spark plugs	<input type="checkbox"/>	<input type="checkbox"/>
Renewing air cleaner insert	<input type="checkbox"/>	<input type="checkbox"/>
Checking or replacing air filter element (for maintenance)	<input type="checkbox"/>	<input type="checkbox"/>
Change brake fluid in entire system	<input type="checkbox"/>	<input type="checkbox"/>

Notes

Stamp, signature

BMW Service

carried out

at _____

Odometer reading _____

Next service

at the latest

at _____

or, when reached earlier

Odometer reading _____

Work performed

	Yes	No
BMW Service	<input type="checkbox"/>	<input type="checkbox"/>
Oil change, engine, with filter	<input type="checkbox"/>	<input type="checkbox"/>
Oil change in rear bevel gears	<input type="checkbox"/>	<input type="checkbox"/>
Checking valve clearance	<input type="checkbox"/>	<input type="checkbox"/>
Renewing all spark plugs	<input type="checkbox"/>	<input type="checkbox"/>
Renewing air cleaner insert	<input type="checkbox"/>	<input type="checkbox"/>
Checking or replacing air filter element (for maintenance)	<input type="checkbox"/>	<input type="checkbox"/>
Change brake fluid in entire system	<input type="checkbox"/>	<input type="checkbox"/>

Notes

Stamp, signature

262 SERVICE

BMW Service

carried out

at _____

Odometer reading _____

Next service

at the latest

at _____

or, when reached earlier

Odometer reading _____

Work performed

	Yes	No
BMW Service	<input type="checkbox"/>	<input type="checkbox"/>
Oil change, engine, with filter	<input type="checkbox"/>	<input type="checkbox"/>
Oil change in rear bevel gears	<input type="checkbox"/>	<input type="checkbox"/>
Checking valve clearance	<input type="checkbox"/>	<input type="checkbox"/>
Renewing all spark plugs	<input type="checkbox"/>	<input type="checkbox"/>
Renewing air cleaner insert	<input type="checkbox"/>	<input type="checkbox"/>
Checking or replacing air filter element (for maintenance)	<input type="checkbox"/>	<input type="checkbox"/>
Change brake fluid in entire system	<input type="checkbox"/>	<input type="checkbox"/>

Notes

Stamp, signature

BMW Service

carried out

at _____

Odometer reading _____

Next service

at the latest

at _____

or, when reached earlier

Odometer reading _____

Work performed

	Yes	No
BMW Service	<input type="checkbox"/>	<input type="checkbox"/>
Oil change, engine, with filter	<input type="checkbox"/>	<input type="checkbox"/>
Oil change in rear bevel gears	<input type="checkbox"/>	<input type="checkbox"/>
Checking valve clearance	<input type="checkbox"/>	<input type="checkbox"/>
Renewing all spark plugs	<input type="checkbox"/>	<input type="checkbox"/>
Renewing air cleaner insert	<input type="checkbox"/>	<input type="checkbox"/>
Checking or replacing air filter element (for maintenance)	<input type="checkbox"/>	<input type="checkbox"/>
Change brake fluid in entire system	<input type="checkbox"/>	<input type="checkbox"/>

Notes

Stamp, signature

264 SERVICE

BMW Service

carried out

at _____

Odometer reading _____

Next service

at the latest

at _____

or, when reached earlier

Odometer reading _____

Work performed

	Yes	No
BMW Service	<input type="checkbox"/>	<input type="checkbox"/>
Oil change, engine, with filter	<input type="checkbox"/>	<input type="checkbox"/>
Oil change in rear bevel gears	<input type="checkbox"/>	<input type="checkbox"/>
Checking valve clearance	<input type="checkbox"/>	<input type="checkbox"/>
Renewing all spark plugs	<input type="checkbox"/>	<input type="checkbox"/>
Renewing air cleaner insert	<input type="checkbox"/>	<input type="checkbox"/>
Checking or replacing air filter element (for maintenance)	<input type="checkbox"/>	<input type="checkbox"/>
Change brake fluid in entire system	<input type="checkbox"/>	<input type="checkbox"/>

Notes

Stamp, signature

BMW Service

carried out

at _____

Odometer reading _____

Next service

at the latest

at _____

or, when reached earlier

Odometer reading _____

Work performed

	Yes	No
BMW Service	<input type="checkbox"/>	<input type="checkbox"/>
Oil change, engine, with filter	<input type="checkbox"/>	<input type="checkbox"/>
Oil change in rear bevel gears	<input type="checkbox"/>	<input type="checkbox"/>
Checking valve clearance	<input type="checkbox"/>	<input type="checkbox"/>
Renewing all spark plugs	<input type="checkbox"/>	<input type="checkbox"/>
Renewing air cleaner insert	<input type="checkbox"/>	<input type="checkbox"/>
Checking or replacing air filter element (for maintenance)	<input type="checkbox"/>	<input type="checkbox"/>
Change brake fluid in entire system	<input type="checkbox"/>	<input type="checkbox"/>

Notes

Stamp, signature

266 SERVICE

BMW Service

carried out

at _____

Odometer reading _____

Next service

at the latest

at _____

or, when reached earlier

Odometer reading _____

Work performed

	Yes	No
BMW Service	<input type="checkbox"/>	<input type="checkbox"/>
Oil change, engine, with filter	<input type="checkbox"/>	<input type="checkbox"/>
Oil change in rear bevel gears	<input type="checkbox"/>	<input type="checkbox"/>
Checking valve clearance	<input type="checkbox"/>	<input type="checkbox"/>
Renewing all spark plugs	<input type="checkbox"/>	<input type="checkbox"/>
Renewing air cleaner insert	<input type="checkbox"/>	<input type="checkbox"/>
Checking or replacing air filter element (for maintenance)	<input type="checkbox"/>	<input type="checkbox"/>
Change brake fluid in entire system	<input type="checkbox"/>	<input type="checkbox"/>

Notes

Stamp, signature

BMW Service

carried out

at _____

Odometer reading _____

Next service

at the latest

at _____

or, when reached earlier

Odometer reading _____

Work performed

	Yes	No
BMW Service	<input type="checkbox"/>	<input type="checkbox"/>
Oil change, engine, with filter	<input type="checkbox"/>	<input type="checkbox"/>
Oil change in rear bevel gears	<input type="checkbox"/>	<input type="checkbox"/>
Checking valve clearance	<input type="checkbox"/>	<input type="checkbox"/>
Renewing all spark plugs	<input type="checkbox"/>	<input type="checkbox"/>
Renewing air cleaner insert	<input type="checkbox"/>	<input type="checkbox"/>
Checking or replacing air filter element (for maintenance)	<input type="checkbox"/>	<input type="checkbox"/>
Change brake fluid in entire system	<input type="checkbox"/>	<input type="checkbox"/>

Notes

Stamp, signature

268 SERVICE

BMW Service

carried out

at _____

Odometer reading _____

Next service

at the latest

at _____

or, when reached earlier

Odometer reading _____

Work performed

	Yes	No
BMW Service	<input type="checkbox"/>	<input type="checkbox"/>
Oil change, engine, with filter	<input type="checkbox"/>	<input type="checkbox"/>
Oil change in rear bevel gears	<input type="checkbox"/>	<input type="checkbox"/>
Checking valve clearance	<input type="checkbox"/>	<input type="checkbox"/>
Renewing all spark plugs	<input type="checkbox"/>	<input type="checkbox"/>
Renewing air cleaner insert	<input type="checkbox"/>	<input type="checkbox"/>
Checking or replacing air filter element (for maintenance)	<input type="checkbox"/>	<input type="checkbox"/>
Change brake fluid in entire system	<input type="checkbox"/>	<input type="checkbox"/>

Notes

Stamp, signature

BMW Service

carried out

at _____

Odometer reading _____

Next service

at the latest

at _____

or, when reached earlier

Odometer reading _____

Work performed

	Yes	No
BMW Service	<input type="checkbox"/>	<input type="checkbox"/>
Oil change, engine, with filter	<input type="checkbox"/>	<input type="checkbox"/>
Oil change in rear bevel gears	<input type="checkbox"/>	<input type="checkbox"/>
Checking valve clearance	<input type="checkbox"/>	<input type="checkbox"/>
Renewing all spark plugs	<input type="checkbox"/>	<input type="checkbox"/>
Renewing air cleaner insert	<input type="checkbox"/>	<input type="checkbox"/>
Checking or replacing air filter element (for maintenance)	<input type="checkbox"/>	<input type="checkbox"/>
Change brake fluid in entire system	<input type="checkbox"/>	<input type="checkbox"/>

Notes

Stamp, signature

270 SERVICE

BMW Service

carried out

at _____

Odometer reading _____

Next service

at the latest

at _____

or, when reached earlier

Odometer reading _____

Work performed

	Yes	No
BMW Service	<input type="checkbox"/>	<input type="checkbox"/>
Oil change, engine, with filter	<input type="checkbox"/>	<input type="checkbox"/>
Oil change in rear bevel gears	<input type="checkbox"/>	<input type="checkbox"/>
Checking valve clearance	<input type="checkbox"/>	<input type="checkbox"/>
Renewing all spark plugs	<input type="checkbox"/>	<input type="checkbox"/>
Renewing air cleaner insert	<input type="checkbox"/>	<input type="checkbox"/>
Checking or replacing air filter element (for maintenance)	<input type="checkbox"/>	<input type="checkbox"/>
Change brake fluid in entire system	<input type="checkbox"/>	<input type="checkbox"/>

Notes

Stamp, signature

DECLARATION OF CONFORMITY FOR ELECTRONIC IMMOBILISER	275
CERTIFICATE FOR ELECTRONIC IMMOBILISER	281
DECLARATION OF CONFORMITY FOR KEYLESS RIDE	283
CERTIFICATE FOR KEYLESS RIDE	288
DECLARATION OF CONFORMITY FOR TYRE PRESSURE CONTROL (RDC)	292
CERTIFICATE FOR TYRE PRESSURE CONTROL (RDC)	298
DECLARATION OF CONFORMITY FOR INTELLIGENT EMERGENCY CALL	299
DECLARATION OF CONFORMITY FOR ANTI-THEFT ALARM SYSTEM	305
DECLARATION OF CONFORMITY FOR TFT INSTRUMENT CLUSTER	310
CERTIFICATE FOR TFT INSTRUMENT CLUSTER	316

Declaration of Conformity

Radio equipment electronic immobiliser (EWS)

Simplified EU Declaration of Conformity acc. Radio Equipment Directive 2014/53/EU after 12.06.2016 and during transition period



Technical information

Frequency Band: 134 kHz
(Transponder: TMS37145 /
TypeDST80, TMS3705
Transponder Base Station IC)
Output Power: 50 dB μ V/m

Manufacturer and Address

Manufacturer: BECOM Electronics GmbH
Adress: Technikerstraße 1,
A-7442 Hochstraß

Austria

Hiermit erklärt BECOM Electronics GmbH, dass der Funkanlagentyp EWS4 der Richtlinie 2014/53/EU entspricht. Der vollständige Text der EU-Konformitätserklärung ist unter der folgenden Internetadresse verfügbar: <http://www.becom.at/de/download/>

Belgium

Le soussigné, BECOM Electronics GmbH, déclare que l'équipement radioélectrique du type EWS4 est conforme à la directive 2014/53/UE. Le texte complet de la déclaration UE de conformité est disponible à l'adresse internet suivante: <http://www.becom.at/de/download/>

Bulgaria

С настоящото BECOM Electronics GmbH декларира, че този тип радиосъоръжение EWS4 е в съответствие с Директива 2014/53/ЕС. Цялостният текст на ЕС декларацията за съответствие може да се намери на следния интернет адрес: <http://www.becom.at/de/download/>

Cyprus

Με την παρούσα ο/η BECOM Electronics GmbH, δηλώνει ότι ο ραδιοεξοπλισμός EWS4 πληροί την οδηγία 2014/53/ΕΕ. Το πλήρες κείμενο της δήλωσης συμμόρφωσης ΕΕ διατίθεται στην ακόλουθη ιστοσελίδα στο διαδίκτυο: <http://www.becom.at/de/download/>

Czech Republic

Tímto BECOM Electronics GmbH prohlašuje, že typ rádiového zařízení EWS4 je v souladu se směrnicí 2014/53/EU. Úplné znění EU prohlášení o shodě je k dispozici na této internetové adrese: <http://www.becom.at/de/download/>

Germany

Hiermit erklärt BECOM Electronics GmbH, dass der Funkanlagentyp EWS4 der Richtlinie 2014/53/EU entspricht. Der vollständige Text der EU-Konformitätserklärung ist unter der folgenden Internetadresse verfügbar: <http://www.becom.at/de/download/>

Denmark

Hermed erklærer BECOM Electronics GmbH, at radioudstyrstypen EWS4 er i overensstemmelse med direktiv 2014/53/EU. EU-overensstemmelseserklæringens fulde tekst kan findes på følgende internetadresse: <http://www.becom.at/de/download/>

Estonia

Käesolevaga deklareerib BECOM Electronics GmbH, et käesolev raadioseadme tüüp EWS4 vastab direktiivi 2014/53/EL nõuetele. ELi vastavusdeklaratsiooni täielik tekst on kättesaadav järgmisel internetiaadressil: <http://www.becom.at/de/download/>

Spain

Por la presente, BECOM Electronics GmbH declara que el tipo de equipo radioeléctrico EWS4 es conforme con la Directiva 2014/53/UE. El texto completo de la declaración UE de conformidad está disponible en la dirección Internet siguiente: <http://www.becom.at/de/download/>

Finland

BECOM Electronics GmbH vakuuttaa, että radiolaitetyyppi EWS4 on direktiivin 2014/53/EU mukainen.

EU-vaatimustenmukaisuusvakuutus on täysimittainen teksti on saatavilla seuraavassa internetosoitteessa:
<http://www.becom.at/de/download/>

France

Le soussigné, BECOM Electronics GmbH, déclare que l'équipement radioélectrique du type EWS4 est conforme à la directive 2014/53/UE. Le texte complet de la déclaration UE de conformité est disponible à l'adresse internet suivante : <http://www.becom.at/de/download/>

United Kingdom

Hereby, BECOM Electronics GmbH declares that the radio equipment type EWS4 is in compliance with Directive 2014/53/EU
The full text of the EU declaration of conformity is available at the following internet address: <http://www.becom.at/de/download/>

Greece

Με την παρούσα ο/η BECOM Electronics GmbH, δηλώνει ότι ο ραδιοεξοπλισμός EWS4 πληροί την οδηγία 2014/53/ΕΕ.
Το πλήρες κείμενο της δήλωσης συμμόρφωσης ΕΕ διατίθεται στην ακόλουθη ιστοσελίδα στο διαδίκτυο: <http://www.becom.at/de/download/>

Croatia

BECOM Electronics GmbH ovime izjavljuje da je radijska oprema tipa EWS4 u skladu s Direktivom 2014/53/EU.
Cjeloviti tekst EU izjave o sukladnosti dostupan je na sljedećoj internetskoj adresi: <http://www.becom.at/de/download/>

Hungary

BECOM Electronics GmbH igazolja, hogy a EWS4 típusú rádióberendezés megfelel a 2014/53/EU irányelvnek.
Az EU-megfelelőségi nyilatkozat teljes szövege elérhető a következő internetes címen: <http://www.becom.at/de/download/>

Ireland

Hereby, BECOM Electronics GmbH declares that the radio equipment type EWS4 is in compliance with Directive 2014/53/EU.

The full text of the EU declaration of conformity is available at the following internet address: <http://www.becom.at/de/download/>

Italy

Il fabbricante, BECOM Electronics GmbH, dichiara che il tipo di apparecchiatura radio EWS4 è conforme alla direttiva 2014/53/UE. Il testo completo della dichiarazione di conformità UE è disponibile al seguente indirizzo Internet: <http://www.becom.at/de/download/>

Lithuania

Aš, BECOM Electronics GmbH, patvirtinu, kad radijo įrenginių tipas EWS4 atitinka Direktyvą 2014/53/ES.

Visas ES atitikties deklaracijos tekstas prieinamas šiuo interneto adresu: <http://www.becom.at/de/download/>

Luxembourg

Le soussigné, BECOM Electronics GmbH, déclare que l'équipement radioélectrique du type EWS4 est conforme à la directive 2014/53/UE. Le texte complet de la déclaration UE de conformité est disponible à l'adresse internet suivante: <http://www.becom.at/de/download/>

Latvia

Ar šo BECOM Electronics GmbH deklarē, ka radioiekārta EWS4 atbilst Direktīvai 2014/53/ES. Pilns ES atbilstības deklarācijas teksts ir pieejams šādā interneta vietnē: <http://www.becom.at/de/download/>

Malta

B'dan, BECOM Electronics GmbH, niddikjara li dan it-tip ta' tagħmir tar-radju EWS4 huwa konformi mad-Direttiva 2014/53/UE. It-test kollu tad-dikjarazzjoni ta' konformità tal-UE huwa disponibbli f'dan l-indirizz tal-Internet li ġej: <http://www.becom.at/de/download/>

Netherlands

Hierbij verklaar ik, BECOM Electronics GmbH, dat het type radioapparatuur EWS4 conform is met Richtlijn 2014/53/EU. De volledige tekst van de EU-conformiteitsverklaring kan worden geraadpleegd op het volgende internetadres: <http://www.becom.at/de/download/>

Poland

BECOM Electronics GmbH niniejszym oświadcza, że typ urządzenia radiowego EWS4 jest zgodny z dyrektywą 2014/53/UE. Pełny tekst deklaracji zgodności UE jest dostępny pod następującym adresem internetowym: <http://www.becom.at/de/download/>

Portugal

O(a) abaixo assinado(a) BECOM Electronics GmbH declara que o presente tipo de equipamento de rádio EWS4 está em conformidade com a Diretiva 2014/53/UE. O texto integral da declaração de conformidade está disponível no seguinte endereço de Internet: <http://www.becom.at/de/download/>

Romania

Prin prezenta, BECOM Electronics GmbH declară că tipul de echipamente radio EWS4 este în conformitate cu Directiva 2014/53/UE. Textul integral al declarației UE de conformitate este disponibil la următoarea adresă internet: <http://www.becom.at/de/download/>

Sweden

Härmed försäkras BECOM Electronics GmbH att denna typ av radioutrustning EWS4 överensstämmer med direktiv 2014/53/EU. Den fullständiga texten till EU-försäkran om överensstämmelse finns på följande webbadress: <http://www.becom.at/de/download/>

Slovenia

BECOM Electronics GmbH potrjuje, da je tip radijske opreme EWS4 skladen z Direktivo 2014/53/EU. Celotno besedilo izjave EU o skladnosti je na voljo na naslednjem spletnem naslovu: <http://www.becom.at/de/download/>

Slovakia

BECOM Electronics GmbH týmto vyhlasuje, že rádiové zariadenie typu EWS4 je v súlade so smernicou 2014/53/EÚ.

Úplné EÚ vyhlásenie o zhode je k dispozícii na tejto internetovej adrese:

<http://www.becom.at/de/download/>

FCC Approval

Ring aerial in the ignition switch



To verify the authorization of the ignition key, the electronic immobilizer exchanges information with the ignition key via the ring aerial.

This device complies with Part 15 of the FCC rules. Operation is subject to the following two conditions:

- (1) This device may not cause harmful interference, and
- (2) this device must accept any interference received, including interference that may cause undesired operation.

 Any changes or modifications not expressly approved by the party responsible for compliance could void the user's authority to operate the equipment. ◀

Approbation de la FCC

Antenne annulaire présente dans le commutateur d'allumage



Pour vérifier l'autorisation de la clé de contact, le système d'immobilisation électronique échange des informations avec la clé de contact via l'antenne annulaire.

Le présent dispositif est conforme à la partie 15 des règles de la FCC. Son utilisation est soumise aux deux conditions suivantes :

- (1) Le dispositif ne doit pas produire d'interférences nuisibles, et
- (2) le dispositif doit pouvoir accepter toutes les interférences extérieures, y compris celles qui pourraient provoquer une activation inopportune.



Toute modification qui n'aurait qui n'aurait pas été approuvée expressément par l'organisme responsable de l'homologation peut annuler l'autorisation accordée à l'utilisateur pour utiliser le dispositif. ◀

Declaration of Conformity

Radio equipment Keyless Ride

Simplified EU Declaration of Conformity acc. Radio Equipment Directive 2014/53/EU after 12.06.2016 and during transition period



Technical information

Frequency band: 434,42 MHz
Maximum Transmission Power:
10 mW

Manufacturer and Address

Manufacturer: Huf Hülsbeck & Fürst GmbH & Co. KG
Address: Steeger Str. 17, 42551 Velbert, Germany

Bългарски

С настоящото Huf Hülsbeck & Fürst GmbH & Co. KG декларира, че този тип радиосъоръжение HUF5750 е в съответствие с Директива 2014/53/ЕС. Цялостният текст на ЕС декларацията за съответствие може да се намери на следния интернет адрес: <http://www.huf-group.com/eudoc/>

Česky

Tímto Huf Hülsbeck & Fürst GmbH & Co. KG prohlašuje, že typ rádiového zařízení HUF5750 je v souladu se směrnicí 2014/53/EU. Úplné znění EU prohlášení o shodě je k dispozici na této internetové adrese: <http://www.huf-group.com/eudoc>

Dansk

Hermed erklærer Huf Hülsbeck & Fürst GmbH & Co. KG, at radioudstyrstypen HUF5750 er i overensstemmelse med direktiv 2014/53/EU. EU-overensstemmelseserklæringens fulde tekst kan findes på følgende internetadresse: <http://www.huf-group.com/eudoc>

Germany

Hiermit erklärt Huf Hülsbeck & Fürst GmbH & Co. KG, dass der Funkanlagentyp HUF5750 der Richtlinie 2014/53/EU entspricht. Der vollständige Text der EU-Konformitätserklärung ist unter der folgenden Internetadresse verfügbar: <http://www.huf-group.com/eudoc>

Eesti

Käesolevaga deklareerib Huf Hülsbeck & Fürst GmbH & Co. KG, et käesolev raadioseadme tüüp HUF5750 vastab direktiivi 2014/53/EL nõuetele. ELi vastavusdeklaratsiooni täielik tekst on kättesaadav järgmisel internetiaadressil: <http://www.huf-group.com/eudoc>

English

Hereby, Huf Hülsbeck & Fürst GmbH & Co. KG declares that the radio equipment type HUF5750 is in compliance with Directive 2014/53/EU. The full text of the EU declaration of conformity is available at the following internet address: <http://www.huf-group.com/eudoc>

Español

Por la presente, Huf Hülsbeck & Fürst GmbH & Co. KG declara que el tipo de equipo radioeléctrico HUF5750 es conforme con la Directiva 2014/53/UE. El texto completo de la declaración UE de conformidad está disponible en la dirección Internet siguiente: <http://www.huf-group.com/eudoc>

Français

Le soussigné, Huf Hülsbeck & Fürst GmbH & Co. KG, déclare que l'équipement radioélectrique du type HUF5750 est conforme à la directive 2014/53/UE. Le texte complet de la déclaration UE de conformité est disponible à l'adresse internet suivante: <http://www.huf-group.com/eudoc>

Hrvatski

Huf Hülsbeck & Fürst GmbH & Co. KG ovime izjavljuje da je radijska oprema tipa HUF5750 u skladu s Direktivom 2014/53/EU. Cjeloviti tekst EU izjave o sukladnosti dostupan je na sljedećoj internetskoj adresi: <http://www.huf-group.com/eudoc>

Íslenska

Hér Hülsbeck & Fürst GmbH & Co. KG að radióbúnaður gerð HUF5750 tilskipunar 2014/53/EB samsvarandi.

The fullur texti af ESB-samræmisýfirlýsing er í boði á eftirfarandi veffang: <http://www.huf-group.com/eudoc>

Italiano

Il fabbricante, Huf Hülsbeck & Fürst GmbH & Co. KG, dichiara che il tipo di apparecchiatura radio HUF5750 è conforme alla direttiva 2014/53/UE. Il testo completo della dichiarazione di conformità UE è disponibile al seguente indirizzo Internet: <http://www.huf-group.com/eudoc>

Latviski

Ar šo Huf Hülsbeck & Fürst GmbH & Co. KG deklarē, ka radioiekārta HUF5750 atbilst Direktīvai 2014/53/ES. Pilns ES atbilstības deklarācijas teksts ir pieejams šādā interneta vietnē: <http://www.huf-group.com/eudoc>

Lietuvių

Aš, Huf Hülsbeck & Fürst GmbH & Co. KG, patvirtinu, kad radijo įrenginių tipas HUF5750 atitinka Direktyvą 2014/53/ES. Visas ES atitikties deklaracijos tekstas prieinamas šiuo interneto adresu: <http://www.huf-group.com/eudoc>

Magyar

Huf Hülsbeck & Fürst GmbH & Co. KG igazolja, hogy a HUF5750 típusú rádióberendezés megfelel a 2014/53/EU irányelvnek. Az EU-megfelelőségi nyilatkozat teljes szövege elérhető a következő internetes címen: <http://www.huf-group.com/eudoc>

Malti

B'dan, Huf Hülsbeck & Fürst GmbH & Co. KG, niddikjara li dan it-tip ta' tagħmir tar-radju HUF5750 huwa konformi mad-Direttiva 2014/53/UE. It-test kollu tad-dikjarazzjoni ta' konformità tal-UE huwa disponibbli f'dan l-indirizz tal-Internet li ġej: <http://www.huf-group.com/eudoc>

Nederlands

Hierbij verklaar ik, Huf Hülsbeck & Fürst GmbH & Co. KG, dat het type radioapparatuur HUF5750 conform is met Richtlijn 2014/53/EU. De volledige tekst van de EU-conformiteitsverklaring kan worden geraadpleegd op het volgende internetadres: <http://www.huf-group.com/eudoc>

Norsk

Herved Huf Hülsbeck & Fürst GmbH & Co. KG at radioustyrstypen HUF5750 i direktiv 2014/53/EU tilsvarende. Den fullstendige teksten i EU-erklæring er tilgjengelig på følgende internettsadresse: <http://www.huf-group.com/eudoc>

Polski

Huf Hülsbeck & Fürst GmbH & Co. KG niniejszym oświadcza, że typ urządzenia radiowego HUF5750 jest zgodny z dyrektywą 2014/53/UE. Pełny tekst deklaracji zgodności UE jest dostępny pod następującym adresem internetowym: <http://www.huf-group.com/eudoc>

Português

O(a) abaixo assinado(a) Huf Hülsbeck & Fürst GmbH & Co. KG declara que o presente tipo de equipamento de rádio HUF5750 está em conformidade com a Diretiva 2014/53/UE. O texto integral da declaração de conformidade está disponível no seguinte endereço de Internet: <http://www.huf-group.com/eudoc>

Românesc

Prin prezenta, Huf Hülsbeck & Fürst GmbH & Co. KG declară că tipul de echipamente radio HUF5750 este în conformitate cu Directiva 2014/53/UE. Textul integral al declarației UE de conformitate este disponibil la următoarea adresă internet: <http://www.huf-group.com/eudoc>

Slovensko

Huf Hülsbeck & Fürst GmbH & Co. KG potrjuje, da je tip radijske opreme HUF5750 skladen z Direktivo 2014/53/EU. Celotno besedilo izjave EU o skladnosti je na voljo na naslednjem spletnem naslovu: <http://www.huf-group.com/eudoc>

Slovensky

Huf Hülsbeck & Fürst GmbH & Co. KG týmto vyhlasuje, že rádiové zariadenie typu HUF5750 je v súlade so smernicou 2014/53/EÚ. Úplné EÚ vyhlásenie o zhode je k dispozícii na tejto internetovej adrese: <http://www.huf-group.com/eudoc>

Suomi

Huf Hülsbeck & Fürst GmbH & Co. KG vakuuttaa, että radiolaitetyyppi HUF5750 on direktiivin 2014/53/EU mukainen. EU-vaatimustenmukaisuusvakuutuksen täysimittainen teksti on saatavilla seuraavassa internetosoitteessa: <http://www.huf-group.com/eudoc>

Svenska

Härmed försäkras Huf Hülsbeck & Fürst GmbH & Co. KG att denna typ av radioutrustning HUF5750 överensstämmer med direktiv 2014/53/EU. Den fullständiga texten till EU-försäkran om överensstämmelse finns på följande webbadress: <http://www.huf-group.com/eudoc>

Ελληνική

Με την παρούσα ο/η Huf Hülsbeck & Fürst, δηλώνει ότι ο ραδιοεξοπλισμός HUF5750 πληροί την οδηγία 2014/53/ΕΕ. Το πλήρες κείμενο της δήλωσης συμμόρφωσης ΕΕ διατίθεται στην ακόλουθη ιστοσελίδα στο διαδίκτυο: <http://www.huf-group.com/eudoc>

Certifications

BMW Keyless Ride ID Device



USA, Canada:

Product name: BMW Keyless Ride ID
Device FCC ID: YGOHUF5750
IC: 4008C-HUF5750



Any changes or modifications not expressly approved by the party responsible for compliance could void the user's authority to operate the equipment.

Canada:

Operation is subject to the following two conditions:

- (1) This device may not cause harmful interference, and
- (2) this device must accept any interference received, including interference that may cause undesired operation.

USA:

This device complies with Part 15 of the FCC rules. Operation is subject to the following two conditions:

- (1) This device may not cause harmful interference, and
- (2) this device must accept any interference received, including interference that may cause undesired operation.

Argentina:

CNC COMISIÓN NACIONAL
DE COMUNICACIONES

H-17115

Declaration Of Conformity

We declare under our responsibility that the product

BMW Keyless Ride ID Device (Model: HUF5750)

complies with the appropriate essential requirements of the article 3 of the R&TIE and the other relevant provisions, when used for its intended purpose. Applied Standards:

1. Health and safety requirements contained in article 3 (1) a)
 - EN 60950-1:2006+A11:2009+A1:2010+A12:2011; Information technology equipment-Safety
2. Protection requirements with respect to electromagnetic compatibility article 3 (1) b)
 - EN 301 489-1 (V1 .9.2, 09/2011), Electromagnetic compatibility and radio spectrum matters (ERM); Electromagnetic compatibility (EMC) standard for radio equipment and services; Part 1: Common technical requirements
 - EN 301 489-3 (V1.4.1, 08/2002) Electromagnetic compatibility and radio spectrum matters (ERM); Electromagnetic compatibility (EMC) standard for radio equipment and services; Part 3: Specific conditions for short range devices (SRD) operating on frequencies between 9 kHz and 40 GHz
3. Means of the efficient use of the radio frequency spectrum article 3 (2)
 - EN 300 220-1 & -2 (V2.4.1, 05/2012), electromagnetic compatibility and radio spectrum matters (ERM); Short range devices (SRD); Radio equipment to be used in the 25 MHz to 1000 MHz frequency range with power levels ranging up to 500 mW; Part 1: Technical characteristics and test methods. Part 2: Harmonized EN covering essential requirements under article 3.2 of the R&TIE directive

The product is labeled with the CE marking:

CE

Velbert, October 15th, 2013

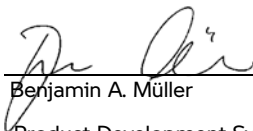

Benjamin A. Müller

Product Development Systems
Car Access and Immobilization -
Electronics Huf Hülsbeck & Fürst
GmbH & Co. KG
Steeger Straße 17, D-42551
Velbert

Declaration of Conformity

Radio equipment tyre pressure control (RDC)

Simplified EU Declaration of Conformity acc. Radio Equipment Directive 2014/53/EU after 12.06.2016 and during transition period



Technical information

Frequency Band: 433.895 -

433.945 MHz

Output Power: <10 mW e.r.p.

Manufacturer and Address

Manufacturer: Schrader Electronics Ltd.

Address: Technology Park, Antrim,
N. Ireland BT41 1QS,
United Kingdom

Austria

Hiermit erklärt Schrader Electronics Ltd., dass der Funkanlagentyp BC5A4 der Richtlinie

2014/53/EU entspricht.

Der vollständige Text der EU-Konformitätserklärung ist unter der folgenden Internetadresse verfügbar:

http://www.tpmseuroshop.com/documents/declaration_conformities

Belgium

Le soussigné, Schrader Electronics Ltd., déclare que l'équipement radioélectrique du type BC5A4 est conforme à la directive 2014/53/UE.

Le texte complet de la déclaration UE de conformité est disponible à l'adresse internet suivante:

http://www.tpmseuroshop.com/documents/declaration_conformities

Cyprus

Με την παρούσα ο/η Schrader Electronics Ltd., δηλώνει ότι ο ραδιοεξοπλισμός BC5A4 πληροί την οδηγία 2014/53/ΕΕ.

Το πλήρες κείμενο της δήλωσης συμμόρφωσης ΕΕ διατίθεται στην ακόλουθη ιστοσελίδα στο διαδίκτυο:

http://www.tpmseuroshop.com/documents/declaration_conformities

Czech Republic

Tímto Schrader Electronics Ltd. prohlašuje, že typ rádiového zařízení BC5A4 je v souladu se směrnicí 2014/53/EU.

Úplné znění EU prohlášení o shodě je k dispozici na této internetové adrese:

http://www.tpmseuroshop.com/documents/declaration_conformities

Germany

Hiermit erklärt Schrader Electronics Ltd., dass der Funkanlagentyp BC5A4 der Richtlinie 2014/53/EU entspricht. Der vollständige Text der EU-Konformitätserklärung ist unter der folgenden Internetadresse verfügbar:

http://www.tpmseuroshop.com/documents/declaration_conformities

Denmark

Hermed erklærer Schrader Electronics Ltd., at radioudstyrstypen BC5A4 er i overensstemmelse med direktiv 2014/53/EU.

EU-overensstemmelseserklæringens fulde tekst kan findes på følgende internetadresse:

http://www.tpmseuroshop.com/documents/declaration_conformities

Estonia

Käesolevaga deklareerib Schrader Electronics Ltd., et käesolev raadioseadme tüüp BC5A4 vastab direktiivi 2014/53/EL nõuetele.

ELi vastavusdeklaratsiooni täielik tekst on kättesaadav järgmisel internetiaadressil:

http://www.tpmseuroshop.com/documents/declaration_conformities

Spain

Por la presente, Schrader Electronics Ltd. declara que el tipo de equipo radioeléctrico BC5A4 es conforme con la Directiva 2014/53/UE.

El texto completo de la declaración UE de conformidad está disponible en la dirección Internet siguiente:

http://www.tpmseuroshop.com/documents/declaration_conformities

Finland

Schrader Electronics Ltd.
vakuuttaa, että radiolaitetyyppi
BC5A4 on direktiivin 2014/53/EU
mukainen.

EU-
vaatimustenmukaisuusvakuutukse
n täysimittainen teksti on saatavilla
seuraavassa internetosoitteessa:
[http://www.tpmseuroshop.com/
documents/
declaration_conformities](http://www.tpmseuroshop.com/documents/declaration_conformities)

France

Le soussigné, Schrader
Electronics Ltd., déclare que
l'équipement radioélectrique du
type BC5A4 est conforme à la
directive 2014/53/UE.
Le texte complet de la déclaration
UE de conformité est disponible à
l'adresse internet suivante:
[http://www.tpmseuroshop.com/
documents/
declaration_conformities](http://www.tpmseuroshop.com/documents/declaration_conformities)

United Kingdom

Hereby, Schrader Electronics Ltd.
declares that the radio equipment
type BC5A4 is in compliance with
Directive 2014/53/EU.
The full text of the EU declaration
of conformity is available at the
following internet address: [http://
www.tpmseuroshop.com/
documents/
declaration_conformities](http://www.tpmseuroshop.com/documents/declaration_conformities)

Greece

Με την παρούσα ο/η Schrader
Electronics Ltd., δηλώνει ότι ο
ραδιοεξοπλισμός BC5A4 πληροί
την οδηγία 2014/53/ΕΕ.
Το πλήρες κείμενο της δήλωσης
συμμόρφωσης ΕΕ διατίθεται στην
ακόλουθη ιστοσελίδα στο
διαδίκτυο:
[http://www.tpmseuroshop.com/
documents/
declaration_conformities](http://www.tpmseuroshop.com/documents/declaration_conformities)

Croatia

Schrader Electronics Ltd. ovime
izjavljuje da je radijska oprema
tipa BC5A4 u skladu s Direktivom
2014/53/EU.
Cjeloviti tekst EU izjave o
sukladnosti dostupan je na
sljedećoj internetskoj adresi:
[http://www.tpmseuroshop.com/
documents/
declaration_conformities](http://www.tpmseuroshop.com/documents/declaration_conformities)

Hungary

Schrader Electronics Ltd. igazolja,
hogy a BC5A4 típusú
rádióberendezés megfelel a
2014/53/EU irányelvnek.
Az EU-megfelelőségi nyilatkozat
teljes szövege elérhető a
következő internetes címen:
[http://www.tpmseuroshop.com/
documents/
declaration_conformities](http://www.tpmseuroshop.com/documents/declaration_conformities)

Ireland

Hereby, Schrader Electronics Ltd. declares that the radio equipment type BC5A4 is in compliance with Directive 2014/53/EU.

The full text of the EU declaration of conformity is available at the following internet address: http://www.tpmseuroshop.com/documents/declaration_conformities

Italy

Il fabbricante, Schrader Electronics Ltd., dichiara che il tipo di apparecchiatura radio BC5A4 è conforme alla direttiva 2014/53/UE.

Il testo completo della dichiarazione di conformità UE è disponibile al seguente indirizzo Internet: http://www.tpmseuroshop.com/documents/declaration_conformities

Lithuania

Aš, Schrader Electronics Ltd., patvirtinu, kad radijo įrenginių tipas BC5A4 atitinka Direktyvą 2014/53/ES.

Visas ES atitiktis deklaracijos tekstas prieinamas šiuo interneto adresu: http://www.tpmseuroshop.com/documents/declaration_conformities

Luxembourg

Le soussigné, Schrader Electronics Ltd., déclare que l'équipement radioélectrique du type BC5A4 est conforme à la directive 2014/53/UE.

Le texte complet de la déclaration UE de conformité est disponible à l'adresse internet suivante: http://www.tpmseuroshop.com/documents/declaration_conformities

Latvia

Ar šo Schrader Electronics Ltd. deklarē, ka radioiekārta BC5A4 atbilst Direktīvai 2014/53/ES. Pilns ES atbilstības deklarācijas teksts ir pieejams šādā interneta vietnē:

http://www.tpmseuroshop.com/documents/declaration_conformities

Malta

B'dan, Schrader Electronics Ltd., niddikjara li dan it-tip ta' tagħmir tar-radju BC5A4 huwa konformi mad-Direttiva 2014/53/UE.

It-test kollu tad-dikjarazzjoni ta' konformità tal-UE huwa disponibbli f'dan l-indirizz tal-Internet li ġej: http://www.tpmseuroshop.com/documents/declaration_conformities

Netherlands

Hierbij verklaar ik, Schrader Electronics Ltd., dat het type radioapparatuur BC5A4 conform is met Richtlijn 2014/53/EU. De volledige tekst van de EU-conformiteitsverklaring kan worden geraadpleegd op het volgende internetadres: http://www.tpmseuroshop.com/documents/declaration_conformities

Poland

Schrader Electronics Ltd. niniejszym oświadcza, że typ urządzenia radiowego BC5A4 jest zgodny z dyrektywą 2014/53/EU. Pełny tekst deklaracji zgodności UE jest dostępny pod następującym adresem internetowym: http://www.tpmseuroshop.com/documents/declaration_conformities

Portugal

O(a) abaixo assinado(a) Schrader Electronics Ltd. declara que o presente tipo de equipamento de rádio BC5A4 está em conformidade com a Diretiva 2014/53/EU. O texto integral da declaração de conformidade está disponível no seguinte endereço de Internet: http://www.tpmseuroshop.com/documents/declaration_conformities

Romania

Prin prezenta, Schrader Electronics Ltd. declară că tipul de echipamente radio BC5A4 este în conformitate cu Directiva 2014/53/UE. Textul integral al declarației UE de conformitate este disponibil la următoarea adresă internet: http://www.tpmseuroshop.com/documents/declaration_conformities

Sweden

Härmed försäkras Schrader Electronics Ltd. att denna typ av radioutrustning BC5A4 överensstämmer med direktiv 2014/53/EU. Den fullständiga texten till EU-försäkran om överensstämmelse finns på följande webbadress: http://www.tpmseuroshop.com/documents/declaration_conformities

Slovenia

Schrader Electronics Ltd. potrjuje, da je tip radijske opreme BC5A4 skladen z Direktivo 2014/53/EU. Celotno besedilo izjave EU o skladnosti je na voljo na naslednjem spletnem naslovu: http://www.tpmseuroshop.com/documents/declaration_conformities

Slovakia

Schrader Electronics Ltd. týmto vyhlasuje, že rádiové zariadenie typu BC5A4 je v súlade so smernicou 2014/53/EÚ.

Úplné EÚ vyhlásenie o zhode je k dispozícii na tejto internetovej adrese:

[http://www.tpmseuroshop.com/
documents/
declaration_conformities](http://www.tpmseuroshop.com/documents/declaration_conformities)

Bulgaria

С настоящото Schrader Electronics Ltd. декларира, че този тип радиосъоръжение BC5A4 е в съответствие с Директива 2014/53/ЕС.

Цялостният текст на ЕС декларацията за съответствие може да се намери на следния интернет адрес:

[http://www.tpmseuroshop.com/
documents/
declaration_conformities](http://www.tpmseuroshop.com/documents/declaration_conformities)

Certification Tire Pressure Control (TPC)

FCC ID: MRXBC54MA4
IC: 2546A-BC54MA4

FCC ID: MRXBC5A4
IC: 2546A-BC5A4

This device complies with Part 15 of the FCC Rules and with Industry Canada license-exempt RSS standard(s).

Operation is subject to the following two conditions:

- (1) This device may not cause harmful interference, and
- (2) This device must accept any interference received, including interference that may cause undesired operation.

WARNING: Changes or modifications not expressly approved by the party responsible for compliance could void the user's authority to operate the equipment. The term "IC:" before the radio certification number only signifies that Industry Canada technical specifications were met.

Le présent appareil est conforme aux CNR d'Industrie Canada applicables aux appareils radio exempts de licence. L'exploitation est autorisée aux deux conditions suivantes:

- (1) l'appareil ne doit pas produire de brouillage, et
- (2) l'utilisateur de l'appareil doit accepter tout brouillage radioélectrique subi, même si le brouillage est susceptible d'en compromettre le fonctionnement.

WARNING: Changes or modifications not expressly approved by the party responsible for compliance could void the user's authority to operate the equipment. The term "IC:" before the radio certification number only signifies that Industry Canada technical specifications were met.

Declaration of Conformity

Radio equipment intelligent emergency call

Simplified EU Declaration of Conformity acc. Radio Equipment Directive 2014/53/EU after 12.06.2016 and during transition period



Technical information

Antenna internal:

Frequency Band: 880 MHz - 915 MHz

Radiated Power [TRP]: < 22 dBm

Not accessible by user:

Frequency Band:
1710 MHz - 1785 MHz

Radiated Power [TRP]: < 26 dBm

Frequency Band:
1920 MHz - 1980 MHz

Radiated Power [TRP]: < 22 dBm

Frequency Band:
880 MHz - 915 MHz

Radiated Power [TRP]: < 23 dBm

Manufacturer and Address

Manufacturer:

Robert Bosch Car Multimedia GmbH

Adress: Robert Bosch Str. 200,
31139 Hildesheim, GERMANY

Austria

Hiermit erklärt Robert Bosch Car Multimedia GmbH, dass der Funkanlagentyp TPM E-CALL EU der Richtlinie 2014/53/EU entspricht.

Der vollständige Text der EU-Konformitätserklärung ist unter der folgenden Internetadresse verfügbar: <http://cert.bosch-carmultimedia.net/>

Belgium

Le soussigné, Robert Bosch Car Multimedia GmbH, déclare que l'équipement radioélectrique du type TPM E-CALL EU est conforme à la directive 2014/53/UE.

Le texte complet de la déclaration UE de conformité est disponible à l'adresse internet suivante: <http://cert.bosch-carmultimedia.net>

Bulgaria

С настоящото Robert Bosch Car Multimedia GmbH декларира, че този тип радиосъоръжение TPM E-CALL EU е в съответствие с Директива 2014/53/ЕС.

Цялостният текст на ЕС декларацията за съответствие може да се намери на следния интернет адрес: <http://cert.bosch-carmultimedia.net/>

Cyprus

Με την παρούσα ο/η Robert Bosch Car Multimedia GmbH, δηλώνει ότι ο ραδιοεξοπλισμός TPM E-CALL EU πληροί την οδηγία 2014/53/ΕΕ. Το πλήρες κείμενο της δήλωσης συμμόρφωσης ΕΕ διατίθεται στην ακόλουθη ιστοσελίδα στο διαδίκτυο: <http://cert.bosch-carmultimedia.net/>

Czech Republic

Tímto Robert Bosch Car Multimedia GmbH prohlašuje, že typ rádiového zařízení TPM E-CALL EU je v souladu se směrnicí 2014/53/EU. Úplné znění EU prohlášení o shodě je k dispozici na této internetové adrese: <http://cert.bosch-carmultimedia.net>

Germany

Hiermit erklärt Robert Bosch Car Multimedia GmbH, dass der Funkanlagentyp TPM E-CALL EU der Richtlinie 2014/53/EU entspricht.

Der vollständige Text der EU-Konformitätserklärung ist unter der folgenden Internetadresse verfügbar: <http://cert.bosch-carmultimedia.net>

Denmark

Hermed erklærer Robert Bosch Car Multimedia GmbH, at radioudstyrstypen TPM E-CALL EU er i overensstemmelse med direktiv 2014/53/EU. EU-overensstemmelseserklæringens fulde tekst kan findes på følgende internetadresse: <http://cert.bosch-carmultimedia.net>

Estonia

Käesolevaga deklareerib Robert Bosch Car Multimedia GmbH, et käesolev raadioseadme tüüp TPM E-CALL EU vastab direktiivi 2014/53/EL nõuetele. ELi vastavusdeklaratsiooni täielik tekst on kättesaadav järgmisel internetiaadressil: <http://cert.bosch-carmultimedia.net>

Spain

Por la presente, Robert Bosch Car Multimedia GmbH declara que el tipo de equipo radioeléctrico TPM E-CALL EU es conforme con la Directiva 2014/53/UE.

El texto completo de la declaración UE de conformidad está disponible en la dirección Internet siguiente: <http://cert.bosch-carmultimedia.net>

Finland

Robert Bosch Car Multimedia GmbH vakuuttaa, että radiolaitetyyppi TPM E-CALL EU on direktiivin 2014/53/EU mukainen.

EU-vaatimustenmukaisuusvakuutuksen täysimittainen teksti on saatavilla seuraavassa internetosoitteessa: <http://cert.bosch-carmultimedia.net>

France

Le soussigné, Robert Bosch Car Multimedia GmbH, déclare que l'équipement radioélectrique du type TPM E-CALL EU est conforme à la directive 2014/53/UE.

Le texte complet de la déclaration UE de conformité est disponible à l'adresse internet suivante: <http://cert.bosch-carmultimedia.net>

United Kingdom

Hereby, Robert Bosch Car Multimedia GmbH declares that the radio equipment type TPM E-CALL EU is in compliance with Directive 2014/53/EU.

The full text of the EU declaration of conformity is available at the following internet address: <http://cert.bosch-carmultimedia.net>

Greece

Με την παρούσα ο/η Robert Bosch Car Multimedia GmbH, δηλώνει ότι ο ραδιοεξοπλισμός TPM E-CALL EU πληροί την οδηγία 2014/53/ΕΕ.

Το πλήρες κείμενο της δήλωσης συμμόρφωσης ΕΕ διατίθεται στην ακόλουθη ιστοσελίδα στο διαδίκτυο: <http://cert.bosch-carmultimedia.net>

Croatia

Robert Bosch Car Multimedia GmbH ovime izjavljuje da je radijska oprema tipa TPM E-CALL EU u skladu s Direktivom 2014/53/EU.

Cjeloviti tekst EU izjave o sukladnosti dostupan je na sljedećoj internetskoj adresi: <http://cert.bosch-carmultimedia.net>

Hungary

Robert Bosch Car Multimedia GmbH igazolja, hogy a TPM E-CALL EU típusú rádióberendezés megfelel a 2014/53/EU irányelvnek.

Az EU-megfelelőségi nyilatkozat teljes szövege elérhető a következő internetes címen: <http://cert.bosch-carmultimedia.net>

Ireland

Hereby, Robert Bosch Car Multimedia GmbH declares that the radio equipment type TPM E-CALL EU is in compliance with Directive 2014/53/EU.

The full text of the EU declaration of conformity is available at the following internet address: <http://cert.bosch-carmultimedia.net>

Italy

Il fabbricante, Robert Bosch Car Multimedia GmbH, dichiara che il tipo di apparecchiatura radio TPM E-CALL EU è conforme al direttiva 2014/53/UE.

Il testo completo della dichiarazione di conformità UE è disponibile al seguente indirizzo Internet: <http://cert.bosch-carmultimedia.net>

Lithuania

Aš, Robert Bosch Car Multimedia GmbH, patvirtinu, kad radijo įrenginių tipas TPM E-CALL EU atitinka Direktyvą 2014/53/ES. Visas ES atitikties deklaracijos tekstas prieinamas šiuo interneto adresu: <http://cert.bosch-carmultimedia.net>

Luxembourg

Le soussigné, Robert Bosch Car Multimedia GmbH, déclare que l'équipement radioélectrique du type TPM E-CALL EU est conforme à la directive 2014/53/UE.

Le texte complet de la déclaration UE de conformité est disponible à l'adresse internet suivante: <http://cert.bosch-carmultimedia.net>

Latvia

Ar šo Robert Bosch Car Multimedia GmbH deklarē, ka radioiekārta TPM E-CALL EU atbilst Direktīvai 2014/53/ES. Pilns ES atbilstības deklarācijas teksts ir pieejams šādā interneta vietnē: <http://cert.bosch-carmultimedia.net>

Malta

B'dan, Robert Bosch Car Multimedia GmbH, niddikjara li dan it-tip ta' tagħmir tar-radju TPM E-CALL EU huwa konformi mad-Direttiva

2014/53/UE.

It-test kollu tad-dikjarazzjoni ta' konformità tal-UE huwa disponibbli f'dan l-indirizz tal-Internet li ġej: <http://cert.bosch-carmultimedia.net>

Netherlands

Hierbij verklaar ik, Robert Bosch Car Multimedia GmbH, dat het type radioapparatuur TPM E-CALL EU conform is met Richtlijn 2014/53/EU. De volledige tekst van de EU-conformiteitsverklaring kan worden geraadpleegd op het volgende internetadres: <http://cert.bosch-carmultimedia.net>

Poland

Robert Bosch Car Multimedia GmbH niniejszym oświadcza, że typ urządzenia radiowego TPM E-CALL EU jest zgodny z dyrektywą 2014/53/UE. Pełny tekst deklaracji zgodności UE jest dostępny pod następującym adresem internetowym: <http://cert.bosch-carmultimedia.net>

Portugal

O(a) abaixo assinado(a) Robert Bosch Car Multimedia GmbH declara que o presente tipo de equipamento de rádio TPM E-CALL EU está em conformidade com a Diretiva 2014/53/UE.

O texto integral da declaração de conformidade está disponível no seguinte endereço de Internet: <http://cert.bosch-carmultimedia.net>

Romania

Prin prezenta, Robert Bosch Car Multimedia GmbH declară că tipul de echipamente radio TPM E-CALL EU este în conformitate cu Directiva 2014/53/UE.

Textul integral al declarației UE de conformitate este disponibil la următoarea adresă internet: <http://cert.bosch-carmultimedia.net>

Sweden

Härmed försäkrar Robert Bosch Car Multimedia GmbH att denna typ av radioutrustning TPM E-CALL EU överensstämmer med direktiv 2014/53/EU.

Den fullständiga texten till EU-försäkran om överensstämmelse finns på följande webbadress: <http://cert.bosch-carmultimedia.net>

Slovenia

Robert Bosch Car Multimedia GmbH potrjuje, da je tip radijske opreme TPM E-CALL EU skladen z Direktivo 2014/53/EU.

Celotno besedilo izjave EU o skladnosti je na voljo na naslednjem spletnem naslovu: <http://cert.bosch-carmultimedia.net>

Slovakia

Robert Bosch Car Multimedia GmbH týmto vyhlasuje, že rádiové zariadenie typu TPM E-CALL EU je v súlade so smernicou 2014/53/EÚ. Úplné EÚ vyhlásenie o zhod je k dispozícii na tejto internetovej adrese: <http://cert.bosch-carmultimedia.net>

Declaration of Conformity

Radio equipment anti-theft alarm (DWA)

Simplified EU Declaration of Conformity acc. Radio Equipment Directive 2014/53/EU after 12.06.2016 and during transition period



Technical information

Frequency Band:
433.05-434.79 MHz
Output Power: 10 mW e.r.p.

Manufacturer and Address

Manufacturer: Meta System S.p.A.
Address: Via Galimberti 5 42124
Reggio Emilia - Italy

Austria

Hiermit erklärt Meta System S.p.A., dass der Funkanlagentyp TXBMWMR der Richtlinie 2014/53/EU entspricht. Der vollständige Text der EU-Konformitätserklärung ist unter der folgenden Internetadresse verfügbar: <https://docs.metasystem.it/>

Belgium

Le soussigné, Meta System S.p.A., déclare que l'équipement radioélectrique du type TXBMWMR est conforme à la directive 2014/53/UE. Le texte complet de la déclaration UE de conformité est disponible à l'adresse internet suivante: <https://docs.metasystem.it/>

Bulgaria

С настоящото Meta System S.p.A. декларира, че този тип радиосъоръжение TXBMWMR е в съответствие с Директива 2014/53/ЕС. Цялостният текст на ЕС декларацията за съответствие може да се намери на следния интернет адрес: <https://docs.metasystem.it/>

Cyprus

Με την παρούσα ο/η Meta System S.p.A., δηλώνει ότι ο ραδιοεξοπλισμός TXBMWMR πληροί την οδηγία 2014/53/ΕΕ. Το πλήρες κείμενο της δήλωσης συμμόρφωσης ΕΕ διατίθεται στην ακόλουθη ιστοσελίδα στο διαδίκτυο: <https://docs.metasystem.it/>

Czech Republic

Tímto Meta System S.p.A. prohlašuje, že typ rádiového zařízení TXBMWMMR je v souladu se směrnicí 2014/53/EU. Úplné znění EU prohlášení o shodě je k dispozici na této internetové adrese:
<https://docs.metasystem.it/>

Germany

Hiermit erklärt Meta System S.p.A., dass der Funkanlagentyp TXBMWMMR der Richtlinie 2014/53/EU entspricht. Der vollständige Text der EU-Konformitätserklärung ist unter der folgenden Internetadresse verfügbar:
<https://docs.metasystem.it/>

Denmark

Hermed erklærer Meta System S.p.A., at radioudstyrstypen TXBMWMMR er i overensstemmelse med direktiv 2014/53/EU. EU-overensstemmelseserklæringens fulde tekst kan findes på følgende internetadresse:
<https://docs.metasystem.it/>

Estonia

Käesolevaga deklareerib Meta System S.p.A., et käesolev raadioseadme tüüp TXBMWMMR vastab direktiivi 2014/53/EL nõuetele. ELi vastavusdeklaratsiooni täielik tekst on kättesaadav järgmisel internetiaadressil: <https://docs.metasystem.it/>

Spain

Por la presente, Meta System S.p.A. declara que el tipo de equipo radioeléctrico TXBMWMMR es conforme con la Directiva 2014/53/UE. El texto completo de la declaración UE de conformidad está disponible en la dirección Internet siguiente: <https://docs.metasystem.it/>

Finland

Meta System S.p.A. vakuuttaa, että radiolaitetyyppi TXBMWMMR on direktiivin 2014/53/EU mukainen. EU-vaatimustenmukaisuusvakuutuksen täysimittainen teksti on saatavilla seuraavassa internetosoitteessa: <https://docs.metasystem.it/>

France

Le soussigné, Meta System S.p.A., déclare que l'équipement radioélectrique du type TXBMWMMR est conforme à la directive 2014/53/UE

Le texte complet de la déclaration UE de conformité est disponible à l'adresse internet suivante : <https://docs.metasystem.it/>

United Kingdom

Hereby, Meta System S.p.A. declares that the radio equipment type TXBMWMMR is in compliance with Directive 2014/53/EU. The full text of the EU declaration of conformity is available at the following internet address: <https://docs.metasystem.it/>

Greece

Με την παρούσα ο/η Meta System S.p.A., δηλώνει ότι ο ραδιοεξοπλισμός TXBMWMMR πληροί την οδηγία 2014/53/ΕΕ. Το πλήρες κείμενο της δήλωσης συμμόρφωσης ΕΕ διατίθεται στην ακόλουθη ιστοσελίδα στο διαδίκτυο: <https://docs.metasystem.it/>

Croatia

Meta System S.p.A. ovime izjavljuje da je radijska oprema tipa TXBMWMMR u skladu s Direktivom 2014/53/EU. Cjeloviti tekst EU izjave o sukladnosti dostupan je na sljedećoj internetskoj adresi: <https://docs.metasystem.it/>

Hungary

Meta System S.p.A. igazolja, hogy a TXBMWMMR típusú rádióberendezés megfelel a 2014/53/EU irányelvnek. Az EU-megfelelőségi nyilatkozat teljes szövege elérhető a következő internetes címen: <https://docs.metasystem.it/>

Ireland

Hereby, Meta System S.p.A. declares that the radio equipment type TXBMWMMR is in compliance with Directive 2014/53/EU. The full text of the EU declaration of conformity is available at the following internet address: <https://docs.metasystem.it/>

Italy

Il fabbricante, Meta System S.p.A., dichiara che il tipo di apparecchiatura radio TXBMWMMR è conforme alla direttiva 2014/53/UE. Il testo completo della dichiarazione di conformità UE è disponibile al seguente indirizzo Internet: <https://docs.metasystem.it/>

Lithuania

Aš, Meta System S.p.A., patvirtinu, kad radijo įrenginių tipas TXBMWMMR atitinka Direktyvą 2014/53/ES.

Visas ES atitikties deklaracijos tekstas prieinamas šiuo interneto adresu: <https://docs.metasystem.it/>

Luxembourg

Le soussigné, Meta System S.p.A., déclare que l'équipement radioélectrique du type TXBMWMMR est conforme à la directive 2014/53/UE.

Le texte complet de la déclaration UE de conformité est disponible à l'adresse internet suivante: <https://docs.metasystem.it/>

Latvia

Ar šo Meta System S.p.A. deklarē, ka radioiekārta TXBMWMMR atbilst Direktīvai 2014/53/ES.

Pilns ES atbilstības deklarācijas teksts ir pieejams šādā interneta vietnē: <https://docs.metasystem.it/>

Malta

B'dan, Meta System S.p.A., niddikjara li dan it-tip ta' tagħmir tar-radju TXBMWMMR huwa konformi mad-Direttiva 2014/53/UE.

It-test kollu tad-dikjarazzjoni ta' konformità tal-UE huwa disponibbli f'dan l-indirizz tal-Internet li ġej: <https://docs.metasystem.it/>

Netherlands

Hierbij verklaar ik, Meta System S.p.A., dat het type radioapparatuur TXBMWMMR conform is met Richtlijn 2014/53/EU.

De volledige tekst van de EU-conformiteitsverklaring kan worden geraadpleegd op het volgende internetadres: <https://docs.metasystem.it/>

Poland

Meta System S.p.A. niniejszym oświadcza, że typ urządzenia radiowego TXBMWMMR jest zgodny z dyrektywą 2014/53/UE. Pełny tekst deklaracji zgodności UE jest dostępny pod następującym adresem internetowym: <https://docs.metasystem.it/>

Portugal

O(a) abaixo assinado(a) Meta System S.p.A. declara que o presente tipo de equipamento de rádio TXBMWMMR está em conformidade com a Diretiva 2014/53/UE.

O texto integral da declaração de conformidade está disponível no seguinte endereço de Internet: <https://docs.metasystem.it/>

Romania

Prin prezenta, Meta System S.p.A. declară că tipul de echipamente radio TXBMWMR este în conformitate cu Directiva 2014/53/UE. Textul integral al declarației UE de conformitate este disponibil la următoarea adresă internet: <https://docs.metasystem.it/>

Sweden

Härmed försäkrar Meta System S.p.A. att denna typ av radioutrustning TXBMWMR överensstämmer med direktiv 2014/53/EU. Den fullständiga texten till EU-försäkran om överensstämmelse finns på följande webbadress: <https://docs.metasystem.it/>

Slovenia

Meta System S.p.A. potrjuje, da je tip radijske opreme TXBMWMR skladen z Direktivo 2014/53/EU. Celotno besedilo izjave EU o skladnosti je na voljo na naslednjem spletnem naslovu: <https://docs.metasystem.it/>

Slovakia

Meta System S.p.A. týmto vyhlasuje, že rádiové zariadenie typu TXBMWMR je v súlade so smernicou 2014/53/EÚ. Úplné EÚ vyhlásenie o zhode je k dispozícii na tejto internetovej adrese: <https://docs.metasystem.it/>

Declaration of Conformity

Radio equipment TFT instrument cluster

Simplified EU Declaration of Conformity acc. Radio Equipment Directive 2014/53/EU after 12.06.2016 and during transition period



Technical information

BT operating frq. Range:
2402 – 2480 MHz
BT version: 4.2 (no BTLE)
BT output power: < 4 dBm
WLAN operating frq. Range:
2412 – 2462 MHz
WLAN standards:
IEEE 802.11 b/g/n
WLAN output power: < 20 dBm

Manufacturer and Address

Manufacturer:
Robert Bosch Car Multimedia
GmbH
Address: Robert Bosch Str. 200,
31139 Hildesheim, GERMANY

Austria

Hiermit erklärt Robert Bosch Car Multimedia GmbH, dass der Funkanlagentyp ICC6.5in der Richtlinie 2014/53/EU entspricht. Der vollständige Text der EU-Konformitätserklärung ist unter der folgenden Internetadresse verfügbar: <http://cert.bosch-carmultimedia.net>

Belgium

Le soussigné, Robert Bosch Car Multimedia GmbH, déclare que l'équipement radioélectrique du type ICC6.5in est conforme à la directive 2014/53/UE. Le texte complet de la déclaration UE de conformité est disponible à l'adresse internet suivante: <http://cert.bosch-carmultimedia.net>

Bulgaria

С настоящото Robert Bosch Car Multimedia GmbH декларира, че този тип радиосъоръжение ICC6.5in е в съответствие с Директива 2014/53/ЕС. Цялостният текст на ЕС декларацията за съответствие може да се намери на следния интернет адрес: <http://cert.bosch-carmultimedia.net>

Cyprus

Με την παρούσα ο/η Robert Bosch Car Multimedia GmbH, δηλώνει ότι ο ραδιοεξοπλισμός ICC6.5in πληροί την οδηγία 2014/53/EE. Το πλήρες κείμενο της δήλωσης συμμόρφωσης ΕΕ διατίθεται στην ακόλουθη ιστοσελίδα στο διαδίκτυο: <http://cert.bosch-carmultimedia.net>

Czech Republic

Tímto Robert Bosch Car Multimedia GmbH prohlašuje, že typ rádiového zařízení ICC6.5in je v souladu se směrnicí 2014/53/EU. Úplné znění EU prohlášení o shodě je k dispozici na této internetové adrese: <http://cert.bosch-carmultimedia.net>

Germany

Hiermit erklärt Robert Bosch Car Multimedia GmbH, dass der Funkanlagentyp ICC6.5in der Richtlinie 2014/53/EU entspricht. Der vollständige Text der EU-Konformitätserklärung ist unter der folgenden Internetadresse verfügbar: <http://cert.bosch-carmultimedia.net/>

Denmark

Hermed erklærer Robert Bosch Car Multimedia GmbH, at radioudstyrstypen ICC6.5in er i overensstemmelse med direktiv 2014/53/EU. EU-overensstemmelseserklæringens fulde tekst kan findes på følgende internetadresse: <http://cert.bosch-carmultimedia.net>

Estonia

Käesolevaga deklareerib Robert Bosch Car Multimedia GmbH, et käesolev raadioseadme tüüp ICC6.5in vastab direktiivi 2014/53/EL nõuetele. ELi vastavusdeklaratsiooni täielik tekst on kättesaadav järgmisel internetiaadressil: <http://cert.bosch-carmultimedia.net>

Spain

Por la presente, Robert Bosch Car Multimedia GmbH declara que el tipo de equipo radioeléctrico ICC6.5in es conforme con la Directiva 2014/53/UE. El texto completo de la declaración UE de conformidad está disponible en la dirección Internet siguiente: <http://cert.bosch-carmultimedia.net>

Finland

Robert Bosch Car Multimedia GmbH vakuuttaa, että radiolaitetyyppi ICC6.5in on direktiivin 2014/53/EU mukainen. EU-vaatimustenmukaisuusvakuutukseen täysimittainen teksti on saatavilla seuraavassa internetosoitteessa: <http://cert.bosch-carmultimedia.net>

France

Le soussigné, Robert Bosch Car Multimedia GmbH, déclare que l'équipement radioélectrique du type ICC6.5in est conforme à la directive 2014/53/UE. Le texte complet de la déclaration UE de conformité est disponible à l'adresse internet suivante: <http://cert.bosch-carmultimedia.net>

United Kingdom

Hereby, Robert Bosch Car Multimedia GmbH declares that the radio equipment type ICC6.5in is in compliance with Directive 2014/53/EU. The full text of the EU declaration of conformity is available at the following internet address: <http://cert.bosch-carmultimedia.net>

Greece

Με την παρούσα ο/η Robert Bosch Car Multimedia GmbH, δηλώνει ότι ο ραδιοεξοπλισμός ICC6.5in πληροί την οδηγία 2014/53/ΕΕ. Το πλήρες κείμενο της δήλωσης συμμόρφωσης ΕΕ διατίθεται στην ακόλουθη ιστοσελίδα στο διαδίκτυο: <http://cert.bosch-carmultimedia.net>

Croatia

Robert Bosch Car Multimedia GmbH ovime izjavljuje da je radijska oprema tipa ICC6.5in u skladu s Direktivom 2014/53/EU. Cjeloviti tekst EU izjave o sukladnosti dostupan je na sljedećoj internetskoj adresi: <http://cert.bosch-carmultimedia.net>

Hungary

Robert Bosch Car Multimedia GmbH igazolja, hogy a ICC6.5in típusú rádióberendezés megfelel a 2014/53/EU irányelvnek. Az EU-megfelelőségi nyilatkozat teljes szövege elérhető a következő internetes címen: <http://cert.bosch-carmultimedia.net>

Ireland

Hereby, Robert Bosch Car Multimedia GmbH declares that the radio equipment type ICC6.5in is in compliance with Directive 2014/53/EU. The full text of the EU declaration of conformity is available at the following internet address: <http://cert.bosch-carmultimedia.net>

Italy

Il fabbricante, Robert Bosch Car Multimedia GmbH, dichiara che il tipo di apparecchiatura radio ICC6.5in è conforme alla direttiva 2014/53/UE.

Il testo completo della dichiarazione di conformità UE è disponibile al seguente indirizzo Internet: <http://cert.bosch-carmultimedia.net>

Lithuania

Aš, Robert Bosch Car Multimedia GmbH, patvirtinu, kad radijo įrenginių tipas ICC6.5in atitinka Direktyvą 2014/53/ES.

Visas ES atitikties deklaracijos tekstas prieinamas šiuo interneto adresu: <http://cert.bosch-carmultimedia.net>

Luxembourg

Le soussigné, Robert Bosch Car Multimedia GmbH, déclare que l'équipement radioélectrique du type ICC6.5in est conforme à la directive 2014/53/UE.

Le texte complet de la déclaration UE de conformité est disponible à l'adresse internet suivante: <http://cert.bosch-carmultimedia.net>

Latvia

Ar šo Robert Bosch Car Multimedia GmbH deklarē, ka radioiekārta ICC6.5in atbilst Direktīvai 2014/53/ES.

Pilns ES atbilstības deklarācijas teksts ir pieejams šādā interneta vietnē: <http://cert.bosch-carmultimedia.net>

Malta

B'dan, Robert Bosch Car Multimedia GmbH, niddikjara li dan it-tip ta' tagħmir tar-radju ICC6.5in huwa konformi mad-Direttiva 2014/53/UE.

It-test kollu tad-dikjarazzjoni ta' konformità tal-UE huwa disponibbli f'dan l-indirizz tal-Internet li ġej: <http://cert.bosch-carmultimedia.net>

Netherlands

Hierbij verklaar ik, Robert Bosch Car Multimedia GmbH, dat het type radioapparatuur ICC6.5in conform is met Richtlijn 2014/53/EU.

De volledige tekst van de EU-conformiteitsverklaring kan worden geraadpleegd op het volgende internetadres: <http://cert.bosch-carmultimedia.net>

Poland

Robert Bosch Car Multimedia GmbH niniejszym oświadcza, że typ urządzenia radiowego ICC6.5in jest zgodny z dyrektywą 2014/53/EU.

Pełny tekst deklaracji zgodności UE jest dostępny pod następującym adresem internetowym: <http://cert.bosch-carmultimedia.net>

Portugal

O(a) abaixo assinado(a) Robert Bosch Car Multimedia GmbH declara que o presente tipo de equipamento de rádio ICC6.5in está em conformidade com a Diretiva 2014/53/EU.

O texto integral da declaração de conformidade está disponível no seguinte endereço de Internet: <http://cert.bosch-carmultimedia.net>

Romania

Prin prezenta, Robert Bosch Car Multimedia GmbH declară că tipul de echipamente radio ICC6.5in este în conformitate cu Directiva 2014/53/UE.

Textul integral al declarației UE de conformitate este disponibil la următoarea adresă internet: <http://cert.bosch-carmultimedia.net>

Sweden

Härmed försäkrar Robert Bosch Car Multimedia GmbH att denna typ av radioutrustning ICC6.5in överensstämmer med direktiv 2014/53/EU.

Den fullständiga texten till EU-försäkran om överensstämmelse finns på följande webbadress: <http://cert.bosch-carmultimedia.net>

Slovenia

Robert Bosch Car Multimedia GmbH potrjuje, da je tip radijske opreme ICC6.5in skladen z Direktivo 2014/53/EU.

Celotno besedilo izjave EU o skladnosti je na voljo na naslednjem spletnem naslovu: <http://cert.bosch-carmultimedia.net>

Slovakia

Robert Bosch Car Multimedia GmbH týmto vyhlasuje, že rádiové zariadenie typu ICC6.5in je v súlade so smernicou 2014/53/EÚ. Úplné EÚ vyhlásenie o zhode je k dispozícii na tejto internetovej adrese: <http://cert.bosch-carmultimedia.net>

Declaration of Conformity

Radio equipment TFT instrument cluster

For all Countries without EU

Technical information

BT operating frq. Range:

2402 – 2480 MHz

BT version: 4.2 (no BTLE)

BT output power: < 4 dBm

WLAN operating frq. Range:

2412 – 2462 MHz

WLAN standards:

IEEE 802.11 b/g/n

WLAN output power: < 20 dBm

Manufacturer and Address

Manufacturer:

Robert Bosch Car Multimedia GmbH

Address: Robert Bosch Str. 200,
31139 Hildesheim, GERMANY

Turkey

Robert Bosch Car Multimedia

GmbH, ICC6.5in tipi telsiz

sisteminin 2014/53/EU

nolu yönetmeliğe uygun olduğunu

beyan eder. AB Uygunluk

Beyanı'nın tam metni, aşağıdaki

internet adresinden görülebilir:

[http://cert.bosch-](http://cert.bosch-carmultimedia.net)

[carmultimedia.net](http://cert.bosch-carmultimedia.net)

Brazil

Este equipamento opera em caráter secundário, isto é, não tem direito a proteção contra interferência prejudicial, mesmo de estações do mesmo tipo, e não pode causar interferência a sistemas operando em caráter primário.

Canada

This device complies with Industry Canada's licence-exempt RSSs and part 15 of the FCC Rules. Operation is subject to the following two conditions:

- (1) this device may not cause interference, and
- (2) this device must accept any interference, including interference that may cause undesired operation of the device.

Changes or modifications not expressly approved by the party responsible for compliance could void the user's authority to operate the equipment.

Le présent appareil est conforme aux CNR d'Industrie Canada applicables aux appareils radio exempts de licence. L'exploitation est autorisée aux deux conditions suivantes : (1) l'appareil ne doit pas produire de brouillage, et (2) l'appareil doit accepter tout brouillage radioélectrique subi, même si le brouillage est susceptible d'en compromettre le fonctionnement.

Korea

적합성평가에 관한 고시
R-CMM-RBR-ICC65IN
상호 : Robert Bosch Car
Multimedia GmbH모델명 :
ICC6.5in
기자재명칭 : 특정소출력 무선기
기
(무선데이터통신시스템용 무선기
기)
제조사 및 제조국가 : Robert
Bosch Car Multimedia GmbH /
포르투갈
제조년월 : 제조년월로 표기
이 기기는 업무용 환경에서 사용
할 목적으로 적합성평가를 받은
기기로서 가정용 환경에
서 사용하는 경우 전파간섭의 우
려가 있습니
다.

Mexico

La operación de este equipo está sujeta a las siguientes dos condiciones:

- (1) es posible que este equipo o dispositivo no cause interferencia perjudicial y
- (2) este equipo o dispositivo debe aceptar cualquier interferencia, incluyendo la que pueda causar su operación no deseada.

Taiwan, Republic of

根據 NCC 低功率電波輻射性電機
管理辦法 規定: 第十二條
經型式認證合格之低功率射頻電
機, 非經許可, 公司、商號或使用
者均不得擅自變更頻率、加大功率
或變更原設計之特性及功能。
第十四條
低功率射頻電機之使用不得影響飛
航安全及干擾合法通信; 經發現有
干擾現象時, 應立即停用, 並改善
至無干擾時方得繼續使用。
前項合法通信,
指依電信法規定作業之無線電通
信。
低功率射頻電機須忍受合法通信或
工業、科學及醫療用電波輻射性電
機設備之干擾。

Thailand

เครื่องโทรคมนาคมและอุปกรณ์ นี้

มีความสอดคล้องตามข้อกำหนดของ กทช.

(This telecommunication equipments is in compliance with NTC requirements)

United States (USA)

This device complies with Industry Canada's licence-exempt RSSs and part 15 of the FCC Rules. Operation is subject to the following two conditions:

- (1) this device may not cause interference, and
- (2) this device must accept any interference, including interference that may cause undesired operation of the device.

Changes or modifications not expressly approved by the party responsible for compliance could void the user's authority to operate the equipment.

Le présent appareil est conforme aux CNR d'Industrie Canada applicables aux appareils radio exempts de licence. L'exploitation est autorisée aux deux conditions suivantes : (1) l'appareil ne doit pas produire de brouillage, et (2) l'appareil doit accepter tout brouillage radioélectrique subi, même si le brouillage est susceptible d'en compromettre le fonctionnement.

320 INDEX

- A**
- Abbreviations and symbols, 4
- ABS
 - Engineering details, 154
 - Self-diagnosis, 137
 - Status indicators, 50
- Accessories
 - General instructions, 210
- Adaptive Headlight, 171
- Air filter
 - Position in the vehicle, 19
 - Replacing the air filter element, 195
- Ambient temperature
 - Display, 38
 - Outside temperature warning, 38
- Anti-theft alarm
 - Indicator light, 24
 - operating, 87
 - Technical data, 246
 - Warning, 42
- B**
- Battery
 - Charge battery when connected, 200
 - Charging battery when disconnected, 201
 - Indicator light for vehicle voltage, 39, 40
 - install, 202
 - Maintenance instructions, 199
 - Removal, 201
 - Technical data, 246
- Bluetooth, 104
 - Pairing, 104
- Brake fluid
 - Checking fluid level, front, 183
 - Checking fluid level, rear, 184
 - Reservoir, front, 19
 - Reservoir, rear, 19
- Brake pads
 - checking front, 181
 - checking rear, 182
 - Running in, 139
- Brakes
 - ABS Pro in detail, 157
 - ABS Pro depending on riding mode, 143
 - Adjusting footbrake lever, 120
 - Adjusting handlebar levers, 119
 - Checking function, 181
 - Checking operation, 181
 - Dynamic Brake Control depending on riding mode, 143
 - Safety instructions, 142
 - Technical data, 243
- C**
- Care
 - Chrome, 230
 - Paintwork preservation, 231
- Cases, 212
- Chassis and suspension
 - Technical data, 242
- Check control
 - Dialogue, 31
 - Reading, 31
- Checklist, 135
- Clock
 - adjusting, 103

- Clutch
 - Adjusting handlebar levers, 118
 - Checking function, 185
 - Technical data, 240
- Coolant
 - Checking fill level, 185
 - Indicator light for excess temperature, 43
 - Topping up, 186
- Cruise control operating, 81
- Currency, 6
- D**
- Damping
 - Adjuster, rear, 18
- Daytime riding lights
 - Automatic daytime riding light, 71
 - manual daytime riding light, 70
- Diagnostic connector
 - disengaging, 205
 - securing, 205
- Dimensions
 - Technical data, 246
- DTC
 - Engineering details, 158
 - Indicator light , 52
 - operating, 73
 - Self-diagnosis, 138
- Dynamic Brake Control, 165
 - Engineering details, 165
- Dynamic engine brake control, 160
- E**
- Electrical system
 - Technical data, 245
- Emergency call
 - Automatically in the event of a light fall, 68
 - Automatically in the event of a severe fall, 68
 - Language, 67
 - manual, 67
 - Notes, 11
 - operate, 66
- Emergency off switch (kill switch), 22, 23
 - operating, 66
- Engine, 44
 - Indicator light for engine control unit, 45
 - Indicator light for engine electronics, 44
 - starting, 136
 - Technical data, 239
 - Warning light, drive malfunction, 44
- Engine oil
 - Checking fill level, 179
 - Electronic oil-level check, 42
 - Filler neck, 19
 - Fill-level indicator, 19
 - Indicator light for engine oil level, 43
 - Technical data, 239
 - topping up, 180
- Equipment, 5
- ESA
 - Control, 21
 - operating, 74
- F**
- Final drive
 - Technical data, 241
- Frame
 - Technical data, 241

322 INDEX

Front-wheel stand
installing, 178

Fuel
Filler neck, 18
Fuel grade, 145
refuelling, 146
refuelling with Keyless
Ride, 147, 148
Technical data, 238

Fuel filler cap emergency
release, 149, 150

Fuel reserve
Range, 102
Warning, 54

Fuses
replacing, 203

G

General views
Indicator and warning
lights, 28
Instrument cluster, 24
Left multifunction switch, 21
left side of vehicle, 18
My vehicle, 107
Right multifunction switch, 22,
23
right side of vehicle, 19
TFT display, 29, 30
Underneath the seat, 20

H

Handlebars
adjusting, 122
Hazard warning flashers
Control, 21, 22, 23
operating, 72

Headlight
Beam throw, 117
Headlight beam-throw
adjustment, 18
Headlight courtesy delay
feature, 60, 69
Heated handlebar grips
Control, 22, 23
operating, 90
Hill Start Control, 84, 169
cannot be activated, 55
Engineering details, 169
Indicator and warning
lights, 54
operating, 84
switching on/off, 85
Hill Start Control Pro
adjusting, 86
Engineering details, 169
operating, 85
Horn, 21

I

Ignition
switching off, 61
switching on, 60
Immobiliser, 64
Reserve key, 61
Indicator lights, 24
Overview, 28
Instrument cluster
Ambient-light brightness
sensor, 24
Overview, 24

J

Jump-starting, 197

K

Keyless Ride

- Battery of the radio-operated key is empty or loss of the radio-operated key, 64
- Electronic immobiliser EWS, 64
- Engaging steering lock, 62
- Fuel filler cap, unlocking, 147, 148
- Switching off ignition, 63
- Switching on ignition, 63
- Warning, 38, 39

Keys, 60, 62

L

Lighting

- Indicator light for bulb fault, 41
- Replacing LED light sources, 197
- Technical data, 246

Lights

- Automatic daytime riding light, 71
- Control, 21
- Headlight courtesy delay feature, 69
- Headlight flasher, operating, 69
- High-beam headlight, operating, 69
- Low-beam headlight, 69
- manual daytime riding light, 70
- Operating auxiliary headlights, 70
- Parking lights, 69
- Side light, 69

Lowered suspension

- Restrictions, 132

Luggage

- Instructions for loading, 133

M

Maintenance

- Maintenance schedule, 256

Maintenance confirmations, 257

Maintenance intervals, 254

Media

- operate, 112

Menu

- calling up, 98

Mirrors

- adjusting, 116
- Adjusting mirror arm, 116
- Adjusting mirrors, 116

Mobility services, 254

Motorcycle

- care, 226
- cleaning, 226
- lashing, 150
- Laying up, 231
- parking, 144
- restoring to use, 231

Multifunction switch

- Overview, left side, 21
- Overview, right side, 22, 23

N

Navigation

- operate, 110

O

Off-roading, 140

On-board computer, 107

On-board voltage

- Warning light, 39, 40

324 INDEX

Operating focus
change, 99

P

Pairing, 104
Parking, 144
Parking light, 69
Performance figures
Technical data, 249
Phone
operate, 112
Power socket
Notes on use, 210
Pre-Ride-Check, 137
Pure Ride
Overview, 29

R

RDC
Engineering details, 166
Warnings, 47
Refuelling, 146
Fuel grade, 145
with Keyless Ride, 147, 148
Remote control
Replacing battery, 65
Rev. counter, 24
Rev. counter, 101
Rider info status line
adjusting, 99, 100
Adjusting, 99, 100
Rider's Manual
Position on the vehicle, 20
Riding mode
adjusting, 77
Control, 22, 23
Engineering details, 161
Setting up PRO riding
mode, 80
Running in, 138

S

Safety instructions
for brakes, 142
for riding, 132
Screw connections, 236
Seat
Position of the height
adjustment, 20
Seat heating
operating, 90
Seats
Adjusting seat height, 124
Lock, 18
Removing and installing, 122
Service, 253
Reporting safety-relevant
defects, 252
Service history, 253
Service-due indicator, 55
Shift assistant
Engineering details, 168
Gear not trained, 55
Riding, 141
Shift lever
Adjusting peg, 119
ShiftCam, 170
Engineering details, 170
Shifting gear
Recommendation to
upshift, 102
Spark plugs
Technical data, 246
Speed Limit Info
Switching on or off, 101
Speedometer, 24
Spring preload
Adjuster, rear, 19
adjusting, 125
Starting, 136
Control, 22, 23

Steering lock
Locking, 60

T

Technical data
Anti-theft alarm, 246
Battery, 246
Brakes, 243
Bulbs, 246
Chassis and suspension, 242
Clutch, 240
Dimensions, 246
Electrical system, 245
Engine, 239
Engine oil, 239
Frame, 241
Fuel, 238
General notes, 5
Performance figures, 249
Rear-wheel drive, 241
Spark plugs, 246
Standards, 5
Transmission, 240
Weights, 249
Wheels and tyres, 244

TFT display, 24
Control, 21
operating, 98, 99
Overview, 29, 30
Select display, 95

Toolkit
Position on the vehicle, 20

Topcase
operating, 215

Torques, 236

Traction control, 158
DTC, 158

Transmission
Technical data, 240

Troubleshooting chart, 234

Turn indicators
Control, 21
Control, right, 22, 23
operating, 72

Type plate
Position on the vehicle, 19

Tyre pressure monitoring RDC
Reading, 46

Tyres
Checking tread depth, 188
Checking tyre pressure, 187
Pressures, 245
Running in, 139
Table of tyre pressures, 20
Technical data, 244
Top speed, 134

U

USB charging interface
Position on the vehicle, 19

V

Value
Reading, 31

Vehicle Identification Number
Position on the vehicle, 19

W

Warning indicator lights, 44
ABS, 50
Anti-theft alarm, 42
Bulb faulty, 41
Coolant temperature, 43
DTC, 52
Engine control unit, 45
Engine electronics, 44
Engine oil level, 43
Fuel reserve, 54
Gear not trained, 55
Hill Start Control, 54, 55
Mode of presentation, 31

326 INDEX

- My vehicle, 107
- On-board voltage, 39, 40
- Outside temperature
 - warning, 38
- RDC, 47
- Warning light, drive
 - malfunction, 44
- Warning light, drive malfunction, 44
- Warning lights, 24
 - Overview, 28
- Warnings, overview, 33
- Weights
 - Payload table, 20
 - Technical data, 249
- Wheels
 - Change of size, 189
 - Checking rims, 188
 - Checking spokes, 189
 - Installing front wheel, 191
 - Installing rear wheel, 194
 - Removing front wheel, 190
 - Technical data, 244
- Windscreen
 - Adjuster, 19
 - adjusting, 118

Details described or illustrated in this booklet may differ from the vehicle's actual specification as purchased, the accessories fitted or the national-market specification. No claims will be entertained as a result of such discrepancies.

Dimensions, weights, fuel consumption and performance data are quoted to the customary tolerances.

The right to modify designs, equipment and accessories is reserved.

Errors and omissions excepted.

© 2020 Bayerische Motoren Werke Aktiengesellschaft
80788 Munich, Germany
Not to be reproduced by any means whatsoever, wholly or in part, without the written permission of BMW Motorrad, After Sales.
Original rider's manual, printed in Germany.

Important data for refuelling:

Fuel

Recommended fuel grade	E5 Super unleaded (max 15 % ethanol, E10/E15) E10 95 ROZ/RON 90 AKI
Alternative fuel grade	E5 Normal unleaded (power- and consumption-related restrictions.) (max 15 % ethanol, E10/E15) E10 91 ROZ/RON 87 AKI
Usable fuel capacity	approx. 20 l
Reserve fuel	approx. 4 l
Tyre pressures	
Tyre pressure, front	2.5 bar, sport riding
	2.5 bar, One-up, tyre cold
	2.5 bar, Two-up mode with load, with cold tyres
Tyre pressure, rear	2.9 bar, One-up, tyre cold
	2.9 bar, Two-up mode with load, with cold tyres

You can find further information on all aspects of your vehicle at: bmw-motorrad.com

BMW recommends **ADVANTEC**
ORIGINAL BMW ENGINE OIL

Order No.: 01 40 9 830 781
06.2020, 1st edition, 01

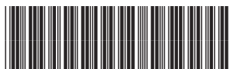

Huomioi seuraavat seikat käyttöohjeen lisäksi.

VAROITUS

Auton avaimessa on nappiparisto. Paristot tai nappiparistot voivat joutua nieluun ja johtaa kahden tunnin sisällä vakaviin tai hengenvaarallisiin vammoihin, esim. sisäisiin palovammoihin tai syöpymävammoihin. Tämä aiheuttaa loukkaantumis- ja hengenvaaran. Säilytä auton avainta ja paristoja lasten ulottumattomissa. Jos epäilet, että paristo tai nappiparisto on nieltä tai se on joutunut kehon sisälle, käänny välittömästi lääkärin puoleen.

HUOMAUTUS

Auton avaimen asetetut epäsovitavat paristot voivat vaurioittaa auton avainta. Tämä aiheuttaa aineellisten vahinkojen vaaran. Vaihda tyhjän pariston tilalle vain jännitearvoltaan, kooltaan ja ominaisuuksiltaan vastaava paristo.

Oltre al libretto Uso e manutenzione, osservare quanto segue.

AVVERTENZA

La chiave della vettura contiene come batteria una batteria a bottone. Le batterie o le batterie a bottone possono essere ingerite ed entro due ore causare lesioni gravi o mortali, ad es. dovute a ustioni o corrosioni interne. Sussiste il pericolo di lesioni o conseguenze letali. Tenere la chiave della vettura e le batterie fuori dalla portata dei bambini. Nel dubbio che una batteria o una batteria a bottone sia stata ingerita o si trovi in una parte del corpo, chiedere immediatamente aiuto medico.

AVVISO

Batterie non adatte nella chiave della vettura possono danneggiare la chiave della vettura stessa. Sussiste il pericolo di danni materiali. Sostituire una batteria scarica soltanto con una batteria con la stessa tensione, la stessa dimensione e la stessa specifica.

Vær også oppmerksom på bruksanvisningen.

ADVARSEL

Batteriet i bilnøkkelen er en knappecelle. Batterier eller knappceller kan svelges og forårsake alvorlig personskade eller død innen to timer, f.eks. som følge av indre forbrenninger eller etseskader. Fare for personskader eller livsfare. Oppbevar bilnøkklene og batteriene utilgjengelig for barn. Hvis du mistenker at et batteri eller en knappecelle er svelget eller befinner seg i noen del av kroppen, må du ringe lege straks.

MERKNAD

Feil batterier i bilnøkkelen kan skade bilnøkkelen. Det er fare for materielle skader. Bytt ut utladet batteri kun med et batteri med samme spenning, størrelse og spesifikasjon.

Opřoč instrukcji obsługi przestrzegaj następujących zaleceń.

OSTRZEŻENIE

W kluczu do pojazdu znajduje się bateria guzikowa. Baterie zwykłe i guzikowe mogą zostać połknięte i w przeciągu dwóch godzin doprowadzić do ciężkich lub śmiertelnych obrażeń, np. w wyniku wewnętrznych oparzeń lub oparzeń chemicznych. Istnieje niebezpieczeństwo odniesienia obrażeń oraz zagrożenie dla życia. Klucz do pojazdu i baterie trzymać poza zasięgiem dzieci. W przypadku podejrzenia, że bateria zwykła lub guzikowa została połknięta lub znajduje się w innej części ciała, bezwzględnie udać się po pomoc medyczną.

WSKAZÓWKA

Niewłaściwa bateria może doprowadzić do uszkodzenia klucza do pojazdu. Istnieje niebezpieczeństwo strat materialnych. Rozładowaną baterię należy wymienić na baterię o takim samym napięciu, o tej samej wielkości i z taką samą specyfikacją.

Naast de handleiding ook het volgende in acht nemen.

WAARSCHUWING

De voertuigsluutel heeft een knoopcel als accu. Accu's of knoopcellen kunnen worden ingeslikt en binnen twee uur tot ernstige of dodelijke letsels leiden, bijv. door verbrandingen. Er bestaat kans op letsel of levensgevaar. Voertuigsluutels en accu's buiten het bereik van kinderen bewaren. Onmiddellijk medische hulp inroepen bij een vermoeden dat een accu of knoopcel werd ingeslikt of zich in een lichaamsdeel bevindt.

OPMERKING

Ongeschikte accu's in de voertuigsluutel kunnen de voertuigsluutel beschadigen. Er bestaat gevaar voor schade. De ontladen accu alleen door een accu met dezelfde spanning, dezelfde grootte en dezelfde specificaties vervangen.

Suplimentar față de manualul de utilizare, respectați următoarele.

⚠️ AVERTIZARE

Cheia autovehiculului conține o baterie sub forma unui element tip buton. Bateriile sau elementele tip buton pot fi înghițite și pot produce vătămări grave sau mortale în interval de două ore, de ex. prin provocarea de arsuri interne sau arsuri caustice. Există pericol de vătămare sau chiar pericol de moarte. Păstrați cheia autovehiculului și bateriile în locuri inaccesibile copiilor. Dacă aveți suspiciunea că o baterie sau un element tip buton a fost înghițit sau se află într-o parte a corpului, apălați imediat medicul.

⚠️ INDICAȚIE

Dacă în cheia autovehiculului se află baterii inadecvate, cheia autovehiculului poate suferi deteriorări. Există pericolul daunelor materiale. Înlocuiți bateria descărcată numai cu o baterie de aceeași tensiune, aceeași mărime și specificație identică.

Επιπρόσθετα στο εγχειρίδιο οδηγών προσέξτε τα παρακάτω.

⚠️ ΠΡΟΕΙΔΟΠΟΙΗΣΗ

Το κλειδί οχήματος περιέχει μια κομβίοσχημη μπαταρία. Οι μπαταρίες ή οι κομβίοσχημες μπαταρίες υπάρχουν κίνδυνος να καταποθούν και εντός δύο ωρών να οδηγήσουν σε σοβαρούς ή θανάσιμους τραυματισμούς, π.χ. εξαιτίας εσωτερικών εγκαυμάτων ή χημικών εγκαυμάτων. Υπάρχει κίνδυνος τραυματισμού ή θανάτου. Φυλάτε το κλειδί οχήματος και τις μπαταρίες μακριά από παιδιά. Αν υπάρχει υποψία κατάποσης μιας κομβίοσχημης μπαταρίας ή μιας μπαταρίας ή ότι αυτή βρισκείται μέσα σε κάποιο μέρος του σώματος, αναζητήστε άμεσα ιατρική βοήθεια.

⚠️ Υπόδειξη

Ακατάλληλες μπαταρίες μέσα στο κλειδί οχήματος μπορούν να προκαλέσουν ζημιά στο κλειδί οχήματος. Υπάρχει κίνδυνος υλικών ζημιών. Αντικαθιστάτε την αποφορτισμένη μπαταρία μόνο με μια μπαταρία ίδιας τάσης, ίδιου μεγέθους και ίδιων προδιαγραφών.

Kromě návodu k obsluze věnujte pozornost následujícímu.

⚠️ VAROVÁNÍ

Klíč vozidla obsahuje knoflíkový článěk jako baterii. Baterie nebo knoflíkové články lze spolknout a během dvou hodin může dojít k těžkému nebo smrtelnému zranění, např. v důsledku vnitřních popálenin nebo poleptání. Hrozí nebezpečí poranění nebo smrtelného úrazu. Klíč vozidla a baterie uchovávejte mimo dosah dětí. Při podezření na spolknutí baterie nebo knoflíkového článku nebo na jejich přítomnost v těle ihned zavolejte lékařskou pomoc.

⚠️ UPOZORNĚNÍ

Nevhodné baterie v klíči vozidla mohou klíč vozidla poškodit. Hrozí nebezpečí hmotných škod. Vybítoou baterii vyměňte pouze za baterii se stejným napětím, stejnými rozměry a stejnou specifikací.

Para além do manual do condutor, respeitar o seguinte.

⚠️ ATENÇÃO

Como bateria, a chave do veículo contém uma pilha tipo botão. As baterias ou as pilhas tipo botão podem ser engolidas e, dentro de duas horas, causar ferimentos graves ou até a morte devido a, por ex., queimaduras químicas internas. Existe risco de lesão ou risco de vida. Guardar a chave do veículo fora do alcance das crianças. Se suspeitar que uma bateria ou pilha tipo botão tenha sido engolida ou se encontra numa parte do corpo, entrar imediatamente em contacto com a assistência médica.

⚠️ AVISO

Baterias inadequadas na chave do veículo podem danificar a chave do veículo. Existe perigo de danos materiais. Substituir a bateria descarregada por uma bateria com a mesma tensão, do mesmo tamanho e da mesma especificação.

Beakta även följande om instruktionsboken.

⚠️ VARNING

Fordonsnyckeln innehåller en knappcell som batteri. Batterier eller knappceller kan sväljas och leda till allvarliga eller dödliga skador inom två timmar, t.ex. genom inre brännskador eller frätskador. Risk för personskador eller livsfara. Förvara fordonsnyckeln och batterierna utom räckhåll för barn. Om du misstänker att någon person har svält ett batteri eller en knappcell eller att den finns i en kroppsdela måste du omedelbart söka medicinsk hjälp.

⚠️ ANVISNING

Olämpliga batterier i fordonsnyckeln kan skada fordonsnyckeln. Risk för materiella skador. Ett urkladat batteri får bara bytas ut mot ett batteri med samma spänning, storlek och specifikation.

A kezelési útmutató mellett vegye figyelembe a következőket.

FIGYELMEZTETÉS

A járműkulcs egy gombalemmel működik. Az elemek, illetve a gombalemegek lenyelhetők, és két órán belül súlyos vagy halálos sérüléseket okozhatnak, például belső gyulladások vagy felmaródások okozásával. Sérülésveszély vagy életveszély áll fenn. A járműkulcsot és az elemeket gyermekektől távol kell tartani. Egy elem, illetve egy gombaleme lenyelésének gyanúja esetén, vagy ha az egy testrészebe kerülne, azonnal kérjen orvosi segítséget.

MEGJEGYZÉS

Csak megfelelő gombalemekekkel használja a járműkulcsot, különben a járműkulcs károsodhat. Anyagi kár veszélye áll fenn. A lemerült elemet csak azonos feszültségű, azonos méretű és azonos jellemzőkkel rendelkező elemmel helyettesítse.

Vær opmærksom på følgende ud over instruktionsbogen.

ADVARSEL

Bilnøglen inderholder et knapbatteri som batteri. Batterier eller knapbatterier kan sluges og i løbet af to timer føre til alvorlige eller dødelige kvæstelser, f.eks. indre forbrændinger eller ætsninger. Der er risiko for kvæstelse eller livsfare. Bilnøgler og batterier skal opbevares utilgængeligt for børn. Hvis der er mistanke om, at et batteri eller et knapbatteri er blevet slugt eller befinder sig i en kropsdel, skal lægen kontaktes omgående.

BEMÆRK

Uegnede batterier i bilnøglen kan beskadige bilnøglen. Der er risiko for materiel skade. Det afladede batteri må kun udskiftes med et batteri med samme spænding, størrelse og specifikationer.

Poleg navodil za uporabo upoštevajte še naslednje.

OPOZORILO

Avtomobilski ključ ima gumbasto celico kot baterijo. V primeru, če pride do zaužitja baterije ali gumbaste celice, lahko to v dveh urah povzroči resne telesne poškodbe ali smrt, npr. zaradi notranjih kemičnih opeklin. Obstaja nevarnost telesnih poškodb ali smrtna nevarnost. Avtomobilski ključ in baterije hranite zunaj dosega otrok. Če obstaja sum, da je prišlo do zaužitja baterije ali gumbaste celice ali da je v katerem koli delu telesa, takoj pokličite zdravniško pomoč.

OPOMBA

Neprimerno baterije v avtomobilskem ključu ga lahko poškodujejo. Obstaja nevarnost materialne škode. Izpraznjeno baterijo lahko zamenjate samo z baterijo enake napetosti, enake velikosti in istih tehničnih specifikacij.

Okrem návod na obsluhu rešpektujte aj nasledujúce pokyny.

VAROVANIE

Kľúč od vozidla obsahuje gombikovú batériu. Hrozi prehltnutie batérie alebo gombikových batérií a v priebehu dvoch hodín vznik vážnych alebo smrteľných poranení, napr. vnútorné popáleniny alebo poleptania. Hrozi nebezpečenstvo zranenia alebo ohrozenie života. Kľúč od vozidla a batérie uchovávajte mimo dosahu detí. Pri podozrení na prehltnutie batérie alebo gombikovej batérie alebo na ich prítomnosť v niektorej časti tela okamžite vyhľadajte lekársku pomoc.

UPOZORNENIE

Nevhodné batérie v kľúči od vozidla ho môžu poškodiť. Hrozi nebezpečenstvo večných škôd. Vybíť batériu nahraďte batériou s rovnakým napätím, rovnakou veľkosťou a rovnakou špecifikáciou.

Please note the following in addition to the information provided in the Owner's Handbook.

⚠ WARNING

The battery inside the vehicle key is a button cell. Batteries or button cells can be swallowed, causing serious or even fatal injuries within two hours, e.g. due to internal burns or cauterisations. There is a danger of injury or danger to life. Keep vehicle keys and batteries out of the reach of children. Seek medical assistance immediately if you suspect that a battery or button cell has been swallowed or has got into a part of the body.

⚠ NOTE

Using unsuitable batteries in a vehicle key can damage the vehicle key. There is a risk of material damage. Discharged batteries should only ever be replaced with batteries of the same voltage, same size and same specification.

Respecter les consignes suivantes en plus de la notice d'utilisation

⚠ AVERTISSEMENT

La clé du véhicule contient une pile bouton. Les batteries ou piles boutons peuvent être avalées et provoquer des blessures graves voire mortelles dans les deux heures, par exemple par des brûlures internes ou des brûlures chimiques. Risque de blessures ou danger de mort. Tenir la clé du véhicule et les batteries hors de la portée des enfants. En cas de suspicion d'ingestion d'une batterie ou d'une pile bouton ou d'introduction dans une partie du corps, contacter immédiatement un médecin.

⚠ REMARQUE

L'insertion de batteries non conformes dans la clé du véhicule peut endommager cette dernière. Risque de dommages matériels. Remplacer la batterie déchargée uniquement par une batterie de tension, de taille et de spécification identiques.

Zusätzlich zur Betriebsanleitung folgendes beachten.

⚠ WARNUNG

Der Fahrzeugschlüssel enthält als Batterie eine Knopfzelle. Batterien oder Knopfzellen können verschluckt werden und innerhalb von zwei Stunden zu schweren oder tödlichen Verletzungen führen, z. B. durch innere Verbrennungen oder Verätzungen. Es besteht Verletzungsgefahr oder Lebensgefahr. Fahrzeugschlüssel und Batterien außerhalb der Reichweite von Kindern aufbewahren. Bei Verdacht, dass eine Batterie oder Knopfzelle verschluckt wurde oder sich in einem Körperteil befindet, sofort medizinische Hilfe rufen.

⚠ HINWEIS

Ungeeignete Batterien im Fahrzeugschlüssel können den Fahrzeugschlüssel beschädigen. Es besteht die Gefahr von Sachschäden. Die entladene Batterie nur durch eine Batterie mit gleicher Spannung, gleicher Größe und gleicher Spezifikation ersetzen.

Observar lo siguiente adicionalmente al manual de instrucciones.

⚠ AVISO

La llave del vehículo contiene una pila de botón a modo de batería. Las pilas o las pilas de botón pueden ser ingeridas y, en el plazo de dos horas, causar lesiones graves o mortales como, p. ej., por quemaduras o abrasiones internas. Existe peligro de lesionarse o peligro de muerte. Mantener la llave del vehículo y las pilas fuera del alcance de los niños. Si sospecha que se ha ingerido una pila o una pila de botón, o que se encuentra en una parte del cuerpo, busque asistencia médica de inmediato.

⚠ INDICACIÓN

Las pilas no adecuadas para la llave del vehículo pueden dañar la misma. Existe peligro de daños materiales. La pila descargada únicamente debe ser sustituida por una pila con la misma tensión, el mismo tamaño y las mismas especificaciones.

© 2020 Bayerische Motoren Werke

Aktiengesellschaft

Munich, Germany

Not to be reproduced, wholly or in part, without written permission from BMW AG, Munich.

Order No.: 01 40 9 831 840

12.2020

Printed on environmentally friendly paper, bleached without chlorine, suitable for recycling.

