



**BMW  
MOTORRAD**

# **RIDER'S MANUAL (US MODEL)**

R nineT



**MAKE LIFE A RIDE**

---

---

**Vehicle data**

Model

---

Vehicle identification number

---

Color number

---

First registration

---

License plate

---

---

**Retailer data**

Contact in Service

---

Ms./Mr.

---

Phone number

---

Retailer's address/Phone (company stamp)

---

# YOUR BMW.

We are pleased that you have chosen a BMW Motorrad vehicle and welcome you to the family of BMW riders. Familiarize yourself with your new vehicle so that you can ride safely and confidently in all traffic situations.

## **About these operating instructions**

Read these operating instructions before starting your new BMW. It contains important notes about operating the vehicle that will enable you to make full use of the technical assets of your BMW.

You will also obtain preventive maintenance and care instructions, which are beneficial to operating and road safety and help retain the value of your vehicle as much as possible.

If you should decide to sell your BMW one day, please remember to hand over these operating instructions as well. They are an important part of your vehicle.

We wish you many miles of safe and enjoyable riding with your BMW

BMW Motorrad.

<b>01 GENERAL INSTRUCTIONS</b>	<b>2</b>	<b>04 OPERATION</b>	<b>38</b>
Quick & easy reference	4	Ignition switch/steering lock	40
Abbreviations and symbols	4	Emergency-off switch	42
Equipment	5	Lights	42
Technical data	5	Hazard warning lights	44
Timeliness of the status of this manual	6	Turn indicators	44
Additional sources of information	6	Display	46
Certificates and operating permits	6	Settings in the instrument cluster	50
Data memory	6	Anti-theft alarm system (DWA)	54
		Traction control (ASC/DTC)	56
		Riding mode	57
		Adaptive cruise control	58
		Heated grips	60
		Rider seat and passenger seat	61
<b>02 OVERVIEWS</b>	<b>12</b>		
Overall view, left side	14	<b>05 SETTING</b>	<b>62</b>
Overall view, right side	15	Mirrors	64
Underneath the seat	16	Headlight	65
Multifunction switch, left	17	Clutch	66
Multifunction switch, right	18	Brake	67
Instrument cluster	19	Spring preload	68
Instrument cluster	20	Damping	70
		Footrest system	72
<b>03 DISPLAYS</b>	<b>22</b>		
Indicator and warning lights	24	<b>06 RIDING</b>	<b>78</b>
Indicator and warning lights	25	Safety instructions	80
Multifunction displays	26	Regular check	82
Indicator lights	27	Starting	83
Service display	36	Breaking in	86
		Brakes	87

Parking your motorcycle	89	Fuses	133
Refueling	90	Diagnostic socket	135
Securing motorcycle for transportation	92		
<hr/>		<b>09 ACCESSORIES</b>	<b>136</b>
<b>07 TECHNOLOGY IN DETAIL</b>	<b>96</b>	General notes	138
General notes	98	USB charging socket	138
Anti-lock braking system (ABS)	98	Luggage	139
Dynamic Brake Control	101	Passenger frame	140
Traction control (ASC/DTC)	101	Hump cover	145
Riding mode	103	Optional accessories	147
Dynamic engine brake control	105		
Adaptive headlights	106	<b>10 CARE</b>	<b>148</b>
<hr/>		Care products	150
<b>08 MAINTENANCE</b>	<b>108</b>	Washing your motorcycle	150
General notes	110	Cleaning sensitive motorcycle parts	151
Onboard vehicle tool kit	111	Paint care	152
Front-wheel stand	111	Paint preservation	153
Rear-wheel stand	112	Storing the motorcycle	153
Engine oil	112	Putting the motorcycle into operation	153
Brake system	114		
Clutch	118	<b>11 TECHNICAL DATA</b>	<b>154</b>
Tires	118	Troubleshooting chart	156
Rims	120	Screw connections	157
Wheels	120	Fuel	160
Light source	129	Engine oil	160
Jump-starting	130	Engine	161
Battery	131	Clutch	162
		Transmission	162
		Rear-wheel drive	162
		Frame	162

<b>Chassis</b>	<b>163</b>
<b>Brakes</b>	<b>164</b>
<b>Wheels and tires</b>	<b>164</b>
<b>Electrical system</b>	<b>165</b>
<b>Dimensions</b>	<b>166</b>
<b>Weights</b>	<b>167</b>
<b>Performance data</b>	<b>167</b>

---

<b>12 SERVICE</b>	<b>168</b>
-------------------	------------

<b>Reporting safety defects</b>	<b>170</b>
<b>BMW Motorrad Service</b>	<b>171</b>
<b>BMW Motorrad Electronic service history (eSH)</b>	<b>171</b>
<b>BMW Motorrad Mobility Services</b>	<b>172</b>
<b>Maintenance work</b>	<b>172</b>
<b>Maintenance schedule</b>	<b>174</b>
<b>Maintenance confirmations</b>	<b>175</b>
<b>Service confirmations</b>	<b>189</b>

---

<b>APPENDIX</b>	<b>192</b>
-----------------	------------

<b>Certificate for electronic immobilizer</b>	<b>193</b>
<b>Declaration of conformity for anti-theft alarm</b>	<b>195</b>

---

<b>INDEX</b>	<b>200</b>
--------------	------------



# **GENERAL IN- STRUCTIONS**

**01**



---

<b>QUICK &amp; EASY REFERENCE</b>	<b>4</b>
<b>ABBREVIATIONS AND SYMBOLS</b>	<b>4</b>
<b>EQUIPMENT</b>	<b>5</b>
<b>TECHNICAL DATA</b>	<b>5</b>
<b>TIMELINESS OF THE STATUS OF THIS MANUAL</b>	<b>6</b>
<b>ADDITIONAL SOURCES OF INFORMATION</b>	<b>6</b>
<b>CERTIFICATES AND OPERATING PERMITS</b>	<b>6</b>
<b>DATA MEMORY</b>	<b>6</b>

## 4 GENERAL INSTRUCTIONS

### QUICK & EASY REFERENCE

Chapter 2 of these operating instructions will provide you with an initial overview of your motorcycle. All maintenance and repair procedures carried out on your motorcycle will be documented in the "Service" chapter. Documentation of the maintenance work performed is a prerequisite for generous treatment of claims.

If you should decide to sell your BMW at some point in the future, please remember to hand over these operating instructions; they are an important part of the motorcycle.

### ABBREVIATIONS AND SYMBOLS



 **CAUTION** Hazard with low risk. Failure to avoid this hazard can result in minor or moderate injury.

 **WARNING** Hazard with moderate risk. Failure to avoid this hazard can result in death or serious injury.

 **DANGER** Hazard with high risk. Failure to avoid this hazard results in death or serious injury.

 **ATTENTION** Special instructions and precautionary measures. Non-compliance can cause damage to the vehicle or accessories and warranty claims may be denied as a result.

 **NOTICE** Special information on operating and inspecting your motorcycle as well as maintenance and adjustment procedures.

- Instruction.
- » Result of an activity.
- ▮ Reference to a page with more detailed information.
- ◁ Indicates the end of accessory or equipment-dependent information.
-  Tightening torque.
-  Technical data.
- OE Optional equipment. BMW Motorrad optional equipment is already completely installed during motorcycle production.

OA	Optional accessories. BMW Motorrad optional accessories can be purchased and retrofitted at your authorized BMW Motorrad retailer.
ABS	Anti-Lock Brake System.
ASC	Automatic Stability Control.
DTC	Dynamic Traction Control.
DWA	Anti-theft alarm.
EWS	Electronic immobilizer.
MSR	Engine drag torque control.

---

## EQUIPMENT

When you ordered your BMW Motorrad motorcycle, you chose various items of custom equipment. These operating instructions describe optional equipment (OE) offered by BMW and selected optional accessories (OA). This explains why the manual may also contain descriptions of equipment which you have not ordered. Please note, too, that your motorcycle might not be

exactly as illustrated in this manual on account of country-specific differences. If your motorcycle features equipment that is not described here, you can find these features described in a separate manual.

---

## TECHNICAL DATA

All dimensions, weights and performance data contained in these operating instructions refer to the German Institute for Standardization i.e. DIN (Deutsches Institut für Normung e. V.) and comply with their tolerance specifications. The technical data and specifications in these operating instructions serve as points of reference. The vehicle-specific data may vary, for instance due to the selected optional equipment, national-market version or country-specific measuring procedures. Detailed values can be obtained from the registration documents or requested from your BMW Motorrad retailer or other qualified service partner or specialist workshop. The information on the vehicle documents always takes precedence over the information in these operating instructions.

## 6 GENERAL INSTRUCTIONS

---

### TIMELINESS OF THE STATUS OF THIS MANUAL

The high safety and quality level of BMW motorcycles are ensured by consistent, ongoing development efforts embracing their design, equipment and accessories. For this reason, some aspects of your motorcycle may vary from the descriptions in these operating instructions. In addition, BMW Motorrad cannot guarantee the total absence of errors. We hope you will appreciate that no claims can be recognized that are based on the data, illustrations or descriptions in this manual.

---

### ADDITIONAL SOURCES OF INFORMATION

#### **BMW Motorrad retailer**

Your BMW Motorrad retailer is always happy to answer any of your questions.

#### **Internet**

The Operating Instructions for your motorcycle, the operating and installation instructions for optional accessories and general BMW Motorrad information related to the technology or other features are available

at [bmw-motorrad.com/manuals](http://bmw-motorrad.com/manuals).

---

### CERTIFICATES AND OPERATING PERMITS

The certificates for the vehicle and the official operating permits for possible accessories are available at [bmw-motorrad.com/certification](http://bmw-motorrad.com/certification).

---

### DATA MEMORY

#### **General information**

Control units are installed in the vehicle. Control units process data received from vehicle sensors, self-generated data or data exchanged between control units, for example. Some control units are required for safe vehicle operation or provide riding assistance, such as driver assistance systems. Control units also make comfort and infotainment functions possible.

Information about the stored or exchanged data can be obtained from the vehicle manufacturer, such as in the form of a separate booklet.

### **Personal references**

Every vehicle is marked with a unique vehicle identification number. Depending on the country, the vehicle owner can be identified using the vehicle identification number and license plate and with the help of the relevant authorities. There are also other ways to trace data obtained from the vehicle back to the driver or vehicle owner, such as via the ConnectedDrive Account that was used.

### **Data privacy laws**

In accordance with applicable data privacy laws, vehicle users have certain rights over the vehicle manufacturer or company that collects or processes personal data.

Vehicle users have the right to obtain comprehensive information without charge from the locations that store the vehicle user's personal data.

These locations may be:

- The vehicle manufacturer
- Qualified service partners
- Specialist workshops
- Service providers

Vehicle users may request information about the type of personal data that is stored, the purpose for which the data will

be used and the source of the data. This information can only be obtained by a registered owner or a person with written proof authorizing use of the vehicle.

The right to information also includes information related to data transmitted to other companies or locations. The vehicle manufacturer's website contains the appropriate privacy policy notices. The privacy policy notices contain information on the right to delete or correct data. The vehicle manufacturer also provides the manufacturer contact information and the contact information of the data security officer.

The vehicle owner can have a BMW Motorrad retailer or other qualified service partner or specialist workshop read out the data stored in the vehicle for a fee if required.

The vehicle data is read out via the vehicle's legally mandated socket for onboard diagnosis (OBD).

## 8 GENERAL INSTRUCTIONS

### **Legal requirements for the disclosure of data**

The vehicle manufacturer is required by the law applicable in this context to provide authorities with the data stored by the manufacturer. Providing this data within the scope required is on a case-by-case basis, for instance to clarify a criminal offense.

Government agencies are authorized by the law applicable in this context to read out the data from the vehicle themselves in individual cases.

### **Operating data in the vehicle**

Control units process data so that the vehicle can run.

Examples of this include:

- Status messages from the vehicle and its individual components, such as wheel RPM, wheel speed and deceleration
- Environmental conditions, such as temperature

The data is processed only in the vehicle itself and is usually temporary. The data is not stored beyond the period in which the vehicle is operating. Electronic components such as control units contain components for storing technical information. This may be information about the vehicle's con-

dition, component load, events or faults stored temporarily or permanently.

This information generally documents the condition of a component, module, system or the surrounding area; for example:

- Operating conditions of system components, such as fill levels and tire pressure
- Malfunctions and faults in key system components, such as lights and brakes
- Vehicle responses in specific riding situations, such as the activation of driving stability control systems
- Information about events causing damage to the vehicle

The data is necessary for providing control unit functions. In addition, it is used by the vehicle manufacturer to detect and eliminate malfunctions as well as to optimize vehicle functions.

The majority of this data is temporary and is processed only within the vehicle itself. Only a small amount of event-driven data is stored in the event data recorder and fault memory.

When a vehicle is serviced, such as for repairs, servicing processes, warranty cases and

quality assurance measures, this technical information can be read out from the vehicle together with the vehicle identification number.

The information can be read out by a BMW Motorrad retailer or other qualified service partner or specialist workshop. The vehicle's legally mandated socket for onboard diagnosis (OBD) is used to read out the data.

The data is collected, processed and used by the respective retailer network locations. The data documents the vehicle's technical states and helps with fault finding, compliance with warranty obligations and quality improvements.

The manufacturer also has product monitoring obligations arising from product liability law. The vehicle manufacturer requires technical data from the vehicle in order to fulfill these obligations. The data from the vehicle can also be used to verify customer warranty and guarantee claims. The fault memory and event data recorder in the vehicle can be reset by a BMW Motorrad retailer or other qualified

service partner or specialist workshop as part of a repair or servicing.

## **Data input and data transfer in the vehicle**

### **General information**

Depending on the equipment, comfort settings and individualized settings in the vehicle can be saved and changed or reset at any time.

Examples of this include:

- Windshield position settings
- Chassis and suspension adjustment settings

It is possible to introduce data into the vehicle entertainment and communication system via a smartphone, for instance.

Depending on the individual equipment, this includes:

- Multimedia data, such as music for playback
- Address book data for use in conjunction with a communication system or integrated navigation system
- Entered navigation destinations
- Data about the use of Internet services. This data can be stored locally in the vehicle or is on a device connected to the vehicle, such as a smartphone, USB stick or MP3 player. If this data is

## 10 GENERAL INSTRUCTIONS

saved in the vehicle, it can be deleted at any time.

This data is transmitted to third parties only upon personal request as part of the use of online services. The data transmitted depends on the selected settings when using the services.

### **Integrating mobile end devices**

Depending on the equipment, mobile end devices connected to the vehicle, such as smartphones, are controlled using the vehicle's operating elements.

This enables audio and visual output from mobile end devices through the multimedia system. At the same time, certain information is transmitted to the mobile end device. This includes for instance position data and other general vehicle data, depending on the type of integration, and makes it possible to optimize the use of selected apps, such as those for navigation or audio playback. The way the data is processed further is determined by the provider of the particular app used. The range of possible settings depends on the particular app and the operating

system of the mobile end device.

### **Services**

#### **General information**

If the vehicle has a mobile phone connection, this connection makes it possible to exchange data between the vehicle and other systems. The mobile phone connection is made possible through the vehicle's transmitter and receiver or via personally integrated mobile end devices such as smartphones. Online functions, as they are called, are used over this mobile phone connection. These include online services and apps provided by the vehicle manufacturer or other providers.

#### **Vehicle manufacturer services**

In the case of the vehicle manufacturer's online services, the particular functions are described at the appropriate location, such as in the operating instructions or on manufacturer's website. The relevant legal information on data privacy is also provided there. Personal data may be used in order to provide online services. The data is exchanged over a secure connection, i.e. with the vehicle manufacturer's IT sys-



tems which are intended for this purpose.

Any collection, processing and use of personal data that goes beyond the provision of services take place only as permitted by law, on the basis of a contractual agreement or as a result of consent. It is also possible to have the entire data connection activated or deactivated. This is not the case for legally prescribed functions.

#### **Services of other providers**

When using the online services of other providers, these services are subject to the responsibility and the data protection and usage conditions of the respective provider. The vehicle manufacturer has no control over the content exchanged via these services. Information about the type, scope and purpose of collecting and using personal data as part of third-party services can be obtained from the particular service provider.

# OVERVIEWS

02

---

<b>OVERALL VIEW, LEFT SIDE</b>	<b>14</b>
<b>OVERALL VIEW, RIGHT SIDE</b>	<b>15</b>
<b>UNDERNEATH THE SEAT</b>	<b>16</b>
<b>MULTIFUNCTION SWITCH, LEFT</b>	<b>17</b>
<b>MULTIFUNCTION SWITCH, RIGHT</b>	<b>18</b>
<b>INSTRUMENT CLUSTER</b>	<b>19</b>
<b>INSTRUMENT CLUSTER</b>	<b>20</b>

# 14 OVERVIEWS

## OVERALL VIEW, LEFT SIDE

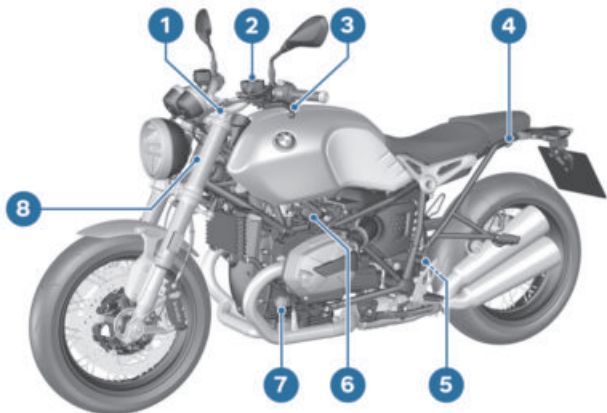

- 1 Adjusting damping on front wheel (➡ 70)
- 2 Checking the clutch function (➡ 118)
- 3 Fuel filler opening (➡ 90)
- 4 Correct loading (➡ 139)
- 5 Adjusting damping at the rear wheel (➡ 71)
- 6 USB charging socket (➡ 138)
- 7 Checking the engine oil level (➡ 112)
- 8 Type plate (on the steering-head bearing)  
Tire pressure table (➡ 118)

---

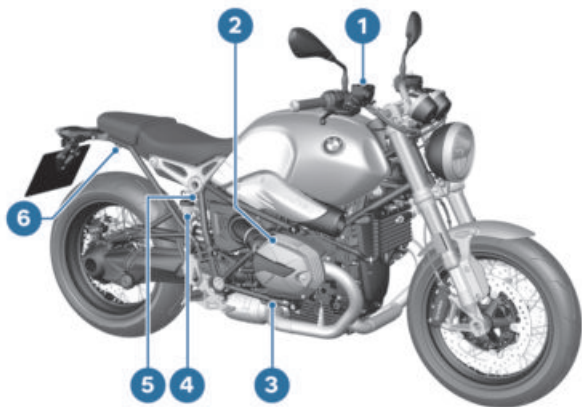
**OVERALL VIEW, RIGHT SIDE**

- 1 Checking the front brake fluid level (►►► 116)
- 2 Topping up the engine oil (►►► 113)
- 3 Vehicle identification number (front right, at the bottom of the rear frame)
- 4 Checking the rear brake fluid level (►►► 117)
- 5 Adjusting spring preload (►►► 69)
- 6 Removing the passenger seat (►►► 61)

# 16 OVERVIEWS

## UNDERNEATH THE SEAT

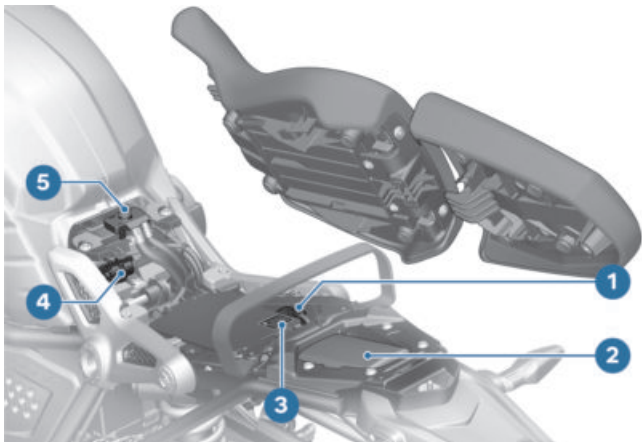

- 1 Loosening the diagnostic socket (▮▮▮▮▶ 135)
- 2 Onboard vehicle tool kit (▮▮▮▮▶ 111)
- 3 Payload table
- 4 Fuse box (▮▮▮▮▶ 133)
- 5 Jump-start terminal (▮▮▮▮▶ 130)

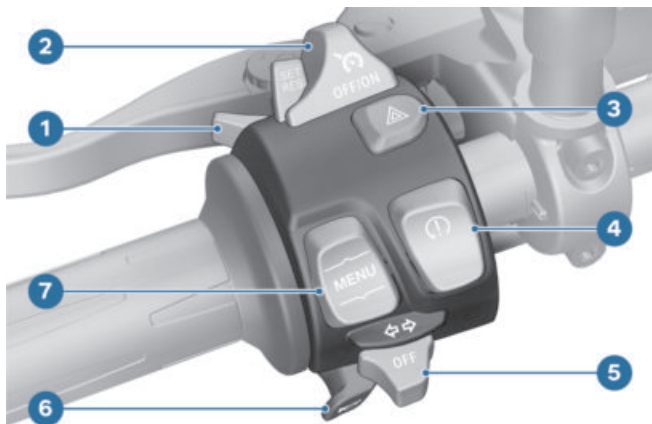
**MULTIFUNCTION SWITCH, LEFT**

- 1 High beams and headlight flasher (►► 43)
- 2 Adaptive cruise control (►► 58)
- 3 Hazard warning flasher (►► 44)
- 4 Traction control (ASC/DTC) (►► 56)
- 5 Turn indicators (►► 44)
- 6 Horn
- 7 Rocker button MENU (►► 46)

## 18 OVERVIEWS

### MULTIFUNCTION SWITCH, RIGHT

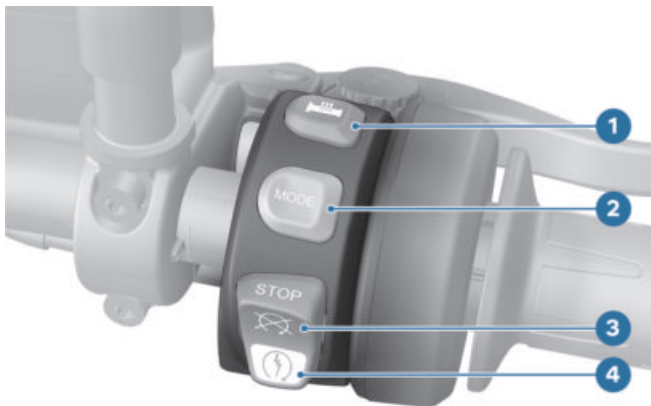

- 1 Operating heated grips  
( 60)
- 2 Select riding mode  
( 57)
- 3 Emergency-off switch  
( 42)
- 4 Starter button ( 83)

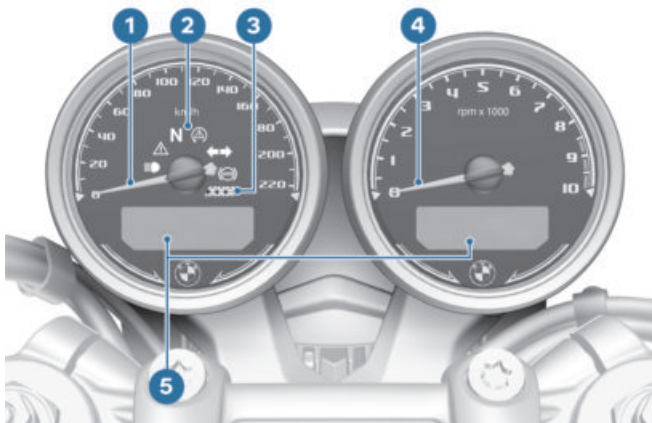

---

**INSTRUMENT CLUSTER**

- 1 Speedometer
- 2 Indicator and warning lights (►► 24)
- 3 Photodiode for brightness control in the multifunction display  
–with anti-theft alarm system (DWA)<sup>OE</sup>  
DWA LED (►► 54)
- 4 Tachometer
- 5 Multifunction displays (►► 26)

## 20 OVERVIEWS

### INSTRUMENT CLUSTER

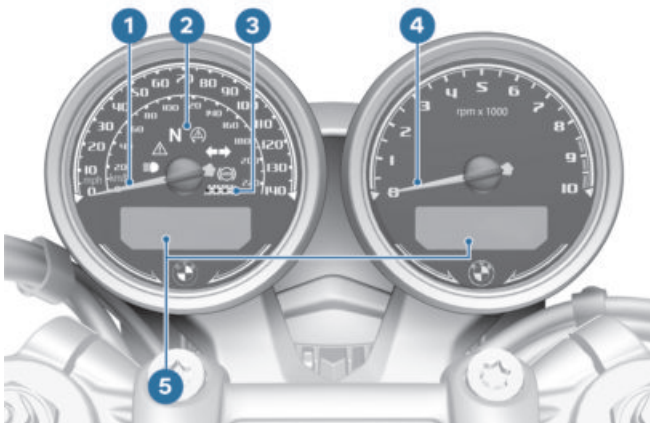

- 1 Speedometer
- 2 Indicator and warning lights (▶▶▶▶ 25)
- 3 Photodiode for brightness control in the multifunction display  
–with anti-theft alarm system (DWA)<sup>OE</sup>  
DWA LED (▶▶▶▶ 54)
- 4 Tachometer
- 5 Multifunction displays (▶▶▶▶ 26)



# DISPLAYS

03

---

<b>INDICATOR AND WARNING LIGHTS</b>	<b>24</b>
<b>INDICATOR AND WARNING LIGHTS</b>	<b>25</b>
<b>MULTIFUNCTION DISPLAYS</b>	<b>26</b>
<b>INDICATOR LIGHTS</b>	<b>27</b>
<b>SERVICE DISPLAY</b>	<b>36</b>

## 24 DISPLAYS

### INDICATOR AND WARNING LIGHTS



- 1 High-beam headlight indicator light (►►► 43)
- 2 General warning light  
Display in combination with warning symbols in the multifunction display (►►► 27)
- 3 Neutral indicator light
- 4 ASC/DTC indicator and warning light (►►► 33)
- 5 Turn signal indicator light (►►► 44)
- 6 ABS indicator and warning light

## INDICATOR AND WARNING LIGHTS



- 1 High-beam headlight indicator light (▬▶ 43)
- 2 General warning light  
Display in combination with warning symbols in the multifunction display (▬▶ 27)
- 3 Neutral indicator light
- 4 ASC/DTC indicator and warning light (▬▶ 33)
- 5 Turn signal indicator light (▬▶ 44)
- 6 ABS indicator and warning light

## 26 DISPLAYS

### MULTIFUNCTION DISPLAYS

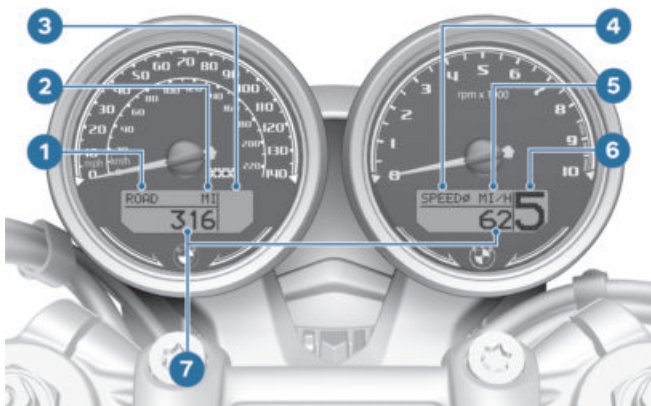

- 1 Select riding mode  
([►►► 57](#))
- 2 Onboard computer  
Selecting displays in the speedometer ([►►► 46](#))  
Unit of the selected display
- 3 Status  
Warning symbol ([►►► 27](#))
- 4 Onboard computer  
Selecting displays in the rotational-speed sensor  
([►►► 48](#))
- 5 Unit of the selected display
- 6 Gear indicator
- 7 Value



---

## INDICATOR LIGHTS

### Layout

Warnings are displayed by means of the corresponding warning lights.

If two or more warnings occur at the same time, all the appropriate warning lights appear.

Warnings are displayed in alternation with warning symbols associated with them.



















You will find an overview of the potential warnings on the following pages.



















Warnings that do not have their own warning light are shown as a warning symbol **1** in the multifunction display in conjunction with the general warning light **2**. The general warning light lights up or flashes depending on the urgency of the warning.

## 28 DISPLAYS

### Overview of warning indicators

Indicator and warning lights	Display text	Meaning
 lights up.	 is displayed.	Electronic immobilizer is active (▬▬▬▶ 30)
 lights up.	 is displayed.	Engine in emergency-operation mode (▬▬▬▶ 30)
 flashes.	 is displayed.	Engine warning (▬▬▬▶ 30)
 flashes.	 is displayed.	Severe drive malfunction (▬▬▬▶ 31)
 lights up.	 is displayed.	Vehicle voltage critical (▬▬▬▶ 31)
 lights up.	 is displayed.	Vehicle voltage too low (▬▬▬▶ 31)
	 is displayed.	Outside temperature warning (▬▬▬▶ 32)
 lights up.	 is displayed.	Light source defective (▬▬▬▶ 32)
 flashes.		ABS self-diagnosis not completed (▬▬▬▶ 32)
 lights up.		ABS error (▬▬▬▶ 32)
 flashes rapidly.		ASC/DTC intervention (▬▬▬▶ 33)
 flashes.		ASC/DTC self-diagnosis not completed (▬▬▬▶ 33)

Indicator and warning lights	Display text	Meaning
	lights up.	ASC/DTC switched off (  33)
	lights up.	ASC/DTC fault (  33)
	 is displayed.	Anti-theft alarm system battery discharged (  34)
	lights up.  and distance recorder KM R or MI R are displayed.	Fuel down to reserve (  35)
	 is displayed.	Service due (  35)
	lights up.  is displayed.	Service overdue (  35)

## 30 DISPLAYS

### Electronic immobilizer is active



lights up.



is displayed.

Possible cause:

The key being used is not authorized for starting, or communication between the key and engine electronics is disrupted.

- Remove other ignition keys from the ignition key ring.
- Have defective ignition keys replaced, preferably by an authorized BMW Motorrad retailer.

### Engine in emergency-operation mode



lights up.



is displayed.



#### WARNING

#### Unusual handling when the engine is in emergency operation

Accident hazard

- Avoid rapid acceleration and passing maneuvers.

Possible cause:

The engine control unit has diagnosed a fault. In exceptional cases, the engine stops and can no longer be started. Otherwise, the engine runs in emergency operation mode.

- Continued driving is possible, however the accustomed engine power output may not be available.
- Have the malfunction corrected as soon as possible at a specialist workshop, preferably an authorized BMW Motorrad retailer.

### Engine warning



flashes.



is displayed.



#### WARNING

#### Damage to engine during emergency operation

Accident hazard

- Drive slowly and avoid rapid acceleration and passing maneuvers.
- If possible, have the vehicle picked up and the fault eliminated at a specialist workshop, preferably an authorized BMW Motorrad retailer.

Possible cause:

The engine control unit has diagnosed a fault, which can lead to a severe secondary fault. The engine is in the emergency-operation mode.

- Avoid high load and engine speed ranges if possible.
  - Have the malfunction corrected as soon as possible at an authorized service facility, preferably an authorized BMW Motorrad Retailer.
- » Continued driving is possible, however it is not recommended.

### Severe drive malfunction



flashes.



is displayed.

Possible cause:

The engine control unit has diagnosed a fault which can lead to damage of the exhaust system.

- Have the malfunction corrected as soon as possible at a specialist workshop, preferably an authorized BMW Motorrad retailer.
- » Continued driving is possible, however it is not recommended.

### Vehicle voltage critical



lights up.



is displayed.

Generator power is no longer sufficient to supply all consumers and charge the battery. In order to ensure that the engine can be started and the vehicle driven, the vehicle electronics switch off individual electrical consumers.

Possible cause:

Too many electrical consumers are turned on. Vehicle voltage tends to drop particularly when the engine is running at low RPMs or idling.

- When riding at low rotational speeds, switch off electrical consumers that are not necessary for driving safety (e.g. heating vests).

### Vehicle voltage too low



lights up.



is displayed.



## WARNING

### Failure of vehicle systems

Accident hazard

- Do not continue riding.

## 32 DISPLAYS

Possible cause:

Alternator or alternator belt is faulty.

- Have the malfunction corrected as soon as possible at an authorized service facility, preferably an authorized BMW Motorrad Retailer.

### Outside temperature warning



is displayed.

Possible cause:

The ambient temperature measured at the motorcycle is lower than 37 °F (3 °C).



### WARNING

#### Risk of black ice, even above 37 °F (3 °C)

Accident hazard

- At a low outside temperature, icy conditions must be expected on bridges and in shady road areas.
- Ride proactively.

### Light source defective



lights up.



is displayed.



### WARNING

#### Overlooking the vehicle in traffic due to a defective light source on the vehicle

Safety risk

- Replace defective light sources as quickly as possible. For details please contact a specialist service facility, preferably an authorized BMW Motorrad Retailer.

### ABS self-diagnosis not completed



flashes.

Possible cause:

The ABS is not available because the self-diagnosis has not been completed. To check the wheel sensors, the motorcycle must be driven a few yards.

- Ride off slowly. It must be noted that the ABS function is not available until the self-diagnosis has been completed.

### ABS error



lights up.

Possible cause:

The ABS control unit has detected an error. The ABS function is not available.

- It is possible to continue riding if you make allowance for the failed ABS function. You should also take account of the additional information on situations that can lead to an ABS fault (►► 99).
- Have the malfunction corrected as soon as possible at a specialist workshop, preferably an authorized BMW Motorrad retailer.

### ASC/DTC intervention



flashes rapidly.

ASC/DTC has detected instability at the rear wheel and responded by reducing the torque. The ASC/DTC indicator and warning light flashes longer than the ASC/DTC intervention lasts. This provides the rider with visual feedback for the control action that was taken even after the critical situation has passed.

### ASC/DTC self-diagnosis not completed



flashes.

Possible cause:



ASC/DTC self-diagnosis not completed

The ASC/DTC function is not available, as the self-diagnosis function has not been completed. (To check wheel speed sensors, motorcycle must reach a minimum speed with engine running: min 3 mph (min 5 km/h))

- Ride off slowly. It must be noted that the ASC/DTC function and the dynamic engine brake control are not available until the self-diagnosis has been completed.

### ASC/DTC switched off



lights up.

Possible cause:

The ASC/DTC system has been switched off by the rider.

- Switching on the ASC/DTC function (►► 56).

### ASC/DTC fault



lights up.

## 34 DISPLAYS

Possible cause:

The ASC/DTC control unit has detected a fault. The ASC/DTC function and the engine drag torque control are not available at all or are restricted.

- You may continue riding. Note that the ASC/DTC function and the dynamic engine brake control are not available at all or are restricted. Observe additional information on situations that can lead to a ASC/DTC fault (▮▮▮▮ 102).
- Have the malfunction corrected as soon as possible at a specialist workshop, preferably an authorized BMW Motorrad retailer.

### Anti-theft alarm system battery discharged

—with anti-theft alarm system (DWA)<sup>OE</sup>



is displayed.

 This fault message is only shown for a short time immediately following the Pre-Ride-Check.

Possible cause:

The DWA battery no longer has any charging capacity. Operation of the DWA is no longer guaranteed when the vehicle battery is disconnected.

- Contact a specialist workshop, preferably an authorized BMW Motorrad retailer.

### Fuel reserve

The fuel quantity in the fuel tank when the low-fuel warning light switches on depends on the riding dynamics. The more the fuel moves around in the fuel tank (due to frequent changes of leaning angle, frequent braking and acceleration), the harder it is to accurately determine the reserve volume. For this reason, the reserve volume cannot be indicated precisely.



After the low-fuel warning light is switched on, the distance recorder for the reserve volume  $KM_R$  or  $MI_R$  is displayed.

The distance that can still be traveled with the reserve volume depends on the riding style (i.e. on fuel consumption) and on the fuel quantity that was still available when the light switched on.



The distance recorder for the reserve volume is reset once the fuel quantity after refueling is greater than the reserve volume.

### Fuel down to reserve



lights up.



and distance recorder  
KM R or MI R are displayed.



### WARNING

#### Rough engine running or switching off of the engine due to a fuel shortage

Accident hazard, damage to catalytic converter

- Do not drive to the extent that the fuel tank is completely empty.

Possible cause:

At the most, the fuel tank still contains the reserve fuel quantity.



Reserve fuel quantity

Approx. 3.7 quarts (Approx. 3.5 l)

- Refueling procedure (▶▶▶ 91).

### Service due



is displayed.

Possible cause:

Service is due because of the mileage or the date.

- Have service performed regularly by a specialist workshop, preferably an authorized BMW Motorrad retailer.
- » The operating safety and road safety of the vehicle remains unchanged.
- » The best-possible value retention of the vehicle is ensured.

### Service overdue



lights up.



is displayed.

Possible cause:

Service is overdue because of the riding performance or the date.

- Have service performed regularly by a specialist workshop, preferably an authorized BMW Motorrad retailer.
- » The operating safety and road safety of the vehicle remains unchanged.
- » The best-possible value retention of the vehicle is ensured.

## 36 DISPLAYS

### SERVICE DISPLAY

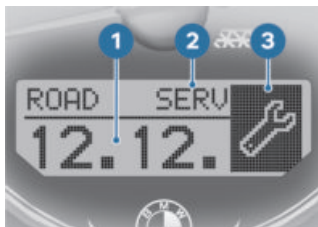

If service is due within a month, the icon for service **3** and the service due date **1** are displayed. **SERV 2** is displayed briefly after the Pre-Ride-Check, or if called up on the onboard computer.



If service is due within 600 miles (1000 km), the icon for service **3** and the remaining distance **1** will be displayed and counted down in steps of 100 miles/kilometers. **SERV 2** is displayed briefly after the Pre-Ride-Check, or if called up on the onboard computer.

 If the service display appears more than one month before the service date, the date stored in the instrument cluster must be set. This situation may occur if the battery is disconnected from the vehicle.



**OPERATION**

**04**

---

<b>IGNITION SWITCH/STEERING LOCK</b>	<b>40</b>
<b>EMERGENCY-OFF SWITCH</b>	<b>42</b>
<b>LIGHTS</b>	<b>42</b>
<b>HAZARD WARNING LIGHTS</b>	<b>44</b>
<b>TURN INDICATORS</b>	<b>44</b>
<b>DISPLAY</b>	<b>46</b>
<b>SETTINGS IN THE INSTRUMENT CLUSTER</b>	<b>50</b>
<b>ANTI-THEFT ALARM SYSTEM (DWA)</b>	<b>54</b>
<b>TRACTION CONTROL (ASC/DTC)</b>	<b>56</b>
<b>RIDING MODE</b>	<b>57</b>
<b>ADAPTIVE CRUISE CONTROL</b>	<b>58</b>
<b>HEATED GRIPS</b>	<b>60</b>
<b>RIDER SEAT AND PASSENGER SEAT</b>	<b>61</b>

## 40 OPERATION

### IGNITION SWITCH/STEERING LOCK

#### Ignition keys

You are provided with 2 ignition keys and one key for removing the passenger seat (▮▮▮ 61).

Should you lose your keys, refer to the notes regarding the electronic immobilizer (EWS) (▮▮▮ 41).

The ignition key fits the ignition steering lock and fuel filler cap.

#### Locking the steering lock



#### ATTENTION

**Handlebars turned in wrong direction when motorcycle propped on side stand.**

Component damage caused by tipping over

- On level ground, always turn the handlebars to the left to set the steering lock.
  - Otherwise the angle of the ground determines whether the handlebars are set to the left or right.
- Turn handlebars to full left or right lock position.



- Turn the ignition key to position **1** while moving the handlebars somewhat.
  - » Ignition, lights and all electrical circuits switched off.
  - » Steering lock locked.
  - » The ignition key can now be removed.

#### Switching on the ignition

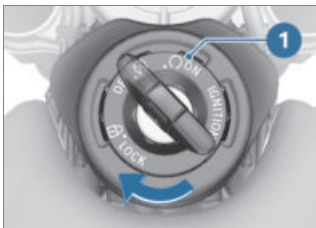

- Turn the ignition key to position **1**.
  - » Parking lights and all function circuits switched on.
  - » Engine can be started.
  - » ABS self-diagnosis is performed. (▮▮▮ 84)
    - with riding modes Pro<sup>OE</sup>
  - » DTC self-diagnosis is performed. (▮▮▮ 86)◁

## Switching off the ignition

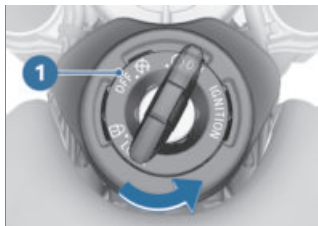

- Turn the ignition key to position **1**.
  - » Light switched off.
  - » Steering lock is not locked.
  - » The ignition key can now be removed.
  - » Electrically powered accessories remain operational for a limited period of time.
  - » Battery can be recharged using the onboard power socket.

### Electronic immobilizer (EWS)

The motorcycle's electronics monitor the data stored in the ignition key through a ring antenna incorporated in the ignition switch / steering lock. The engine control unit does not enable engine start until this key has been recognized as "authorized" for your motorcycle.

 An additional ignition key attached to the same ring as the ignition key used to start

the engine could "irritate" the electronics, in which case the enabling signal for a start is not issued. The warning is displayed in the multifunction display with the key symbol. Always store ignition keys separately from the ignition key used for starting the vehicle.

If you lose an ignition key, you can have it disabled by your authorized BMW Motorrad retailer.

For this purpose, you should also bring all of the motorcycle's remaining ignition keys with you. The engine can no longer be started using a disabled ignition key; however, a disabled ignition key can be enabled again.

Ignition keys can only be obtained from an authorized BMW Motorrad retailer. The ignition keys are part of an integrated safety system, so the retailer is under obligation to check the legitimacy of all applications for spare keys.

## 42 OPERATION

### EMERGENCY-OFF SWITCH



1 Emergency-off switch



#### WARNING

#### Operation of the emergency ON/OFF switch when riding

Danger of falling due to blocking of rear wheel

- Do not operate the emergency ON/OFF switch when riding.

The engine can be switched off easily and quickly using the emergency-off switch.



- A Engine is switched off  
B Operating position



The engine can only be started in the operating position.

### LIGHTS

#### Switch on low-beam headlight

- Switching on the ignition (➡ 40).
- Starting the engine (➡ 83).

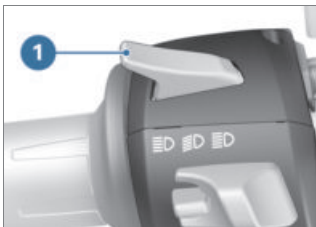

- Alternatively: with the ignition turned on, pull the switch 1.



### Parking lights

The parking lights come on automatically when the ignition is switched on.

 The parking lights are a strain on the battery. Do not leave the ignition switched on longer than absolutely necessary.

### High beams and headlight flasher

- Switching on the ignition (▣▣▣▣ 40).

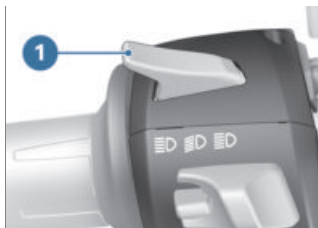

- Press switch **1** forward to switch on high beams.
- Pull switch **1** toward rear to actuate headlight flasher.

### Headlight courtesy delay feature

- Switching off the ignition (▣▣▣▣ 41).

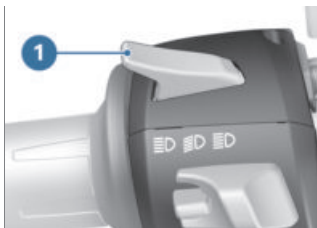

- Immediately after turning off the ignition, pull switch **1** back and hold until the headlight courtesy delay feature turns on.
- » The vehicle lights light up for one minute and then turn off automatically.
- This can be used, for example, to illuminate the path to your front door after the vehicle is parked.

### Parking lights

- Switching off the ignition (▣▣▣▣ 41).



- Immediately after switching off the ignition, push button **1**

## 44 OPERATION

to the left and hold it until the parking lights turn on.

- Switch ignition on and then off again to switch off the parking lights.

---

### HAZARD WARNING LIGHTS

#### Operating the hazard warning lights

 The hazard warning flashers place a strain on the battery. Do not use the hazard warning flashers for longer than absolutely necessary.

 If a turn indicator button is pressed when hazard warning lights are on, the turn indicator function replaces the hazard warning light function for the duration of turn indicator operation. Once the turn indicator button is no longer being pressed, the hazard warning light function will resume.

- Switching on the ignition ( 40).

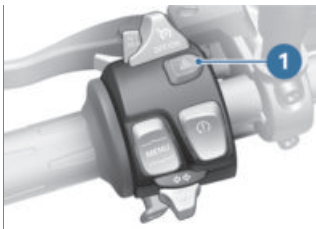

- Press button **1** to switch on the hazard warning lights.  
» Ignition can be switched off.
- To switch off the hazard warning lights, switch on the ignition and press button **1** again.

---

### TURN INDICATORS

#### Operating turn indicators

- Switching on the ignition ( 40).



- Press button **1** to the left to switch on the left-side turn indicators.
- Press button **1** to the right to switch on the right-side turn indicators.

- Move button **1** to the center position to switch off the turn indicators.

### Comfort turn indicators

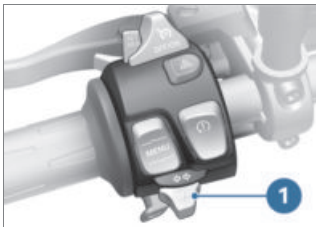

When button **1** is pushed to the right or left, the turn indicators automatically turn off under the following conditions:

- Speed is under 18 mph (30 km/h): after distance of 165 ft (50 m) is covered.
- Speed is between 18 mph and 60 mph (30 km/h and 100 km/h): after a speed-dependent distance is covered or during acceleration.
- Speed is above 60 mph (100 km/h): after turn indicator flashes five times.

When button **1** is pushed to the right or left and held slightly longer, the turn indicators will only turn off automatically after the speed-dependent distance is covered.

## 46 OPERATION

### DISPLAY

#### Selecting displays in the speedometer



#### WARNING

##### **Distraction from traffic conditions and loss of control**

Risk of accident through the use of integrated information systems and communication devices during the journey

- Operate these systems or devices only if the traffic situation allows.
- If necessary, stop and operate the system or devices at a standstill.



## 48 OPERATION

### Selecting displays in the rotational-speed sensor



- Switching on the ignition (→ 40).
  - » The onboard computer is displayed.
- Repeatedly short-press button **1** until desired value is displayed.

Possible displays:

- Engine temperature: bar display
- Average speed: ØMPH
- Vehicle voltage: V
- Average fuel consumption: ØMPG
- Current fuel consumption: MPG, during vehicle standstill: G/H

### Resetting the trip recorder

- Switching on the ignition (▣▣▣▣▶ 40).



- Repeatedly short-press button **1** until the trip recorder to be reset **2** is displayed.
- Press and hold button **1** until trip recorder **2** is reset.

### Resetting average values

- Switching on the ignition (▣▣▣▣▶ 40).



- Press button **1** repeatedly until the desired average value **2** is displayed.
- Press and hold button **1** until the desired average value **2** is reset.

## 50 OPERATION

### SETTINGS IN THE INSTRUMENT CLUSTER

#### Select SETUP Requirement

The vehicle is at a standstill.



- Briefly press button **1** repeatedly until **SETUP ENTER** is displayed.
- Press and hold button **1** to start **SETUP**.
- Briefly press button **1** in each case to select the following parameters in **SETUP**:
  - Adjust the brightness of the backlighting for the instrument cluster **BRIGHT**.
  - with anti-theft alarm system (DWA) <sup>OE</sup>
  - Activate alarm function of anti-theft alarm system automatically after switching off the ignition **DWA ON** or leave switched off **DWA OFF**. ◀
  - Set time display **CLOCK**.
  - Set date **DATE**.
  - Set units **UNIT**.
  - Reset displays **RESET**.

– Exit the **SETUP** menu  
**SETUP EXIT**.

#### Adjusting the display brightness

- Switching on the ignition (▣▣▣▣ 40).
- Select **SETUP** (▣▣▣▣ 50).



- Repeatedly short-press button **1** until **SET BRIGHT** is displayed.
- Briefly press button **2** repeatedly until the desired value for display brightness **3** is set.
  - » A value from 1 to 5 (dark to light) is set for display brightness.
- Press and hold button **1** to exit **SET BRIGHT**.
  - » **SETUP ENTER** is displayed.

#### Setting the clock

- Switching on the ignition (▣▣▣▣ 40).
- Select **SETUP** (▣▣▣▣ 50).





- Repeatedly short-press button **1** until SET CLOCK is displayed.
- Press and hold button **2** until hours **3** flash.
- Briefly press button **1** to increment hours.
- Briefly press button **2** to decrement hours.
- » The hours are set.
- Press and hold button **2** until minutes **4** flash.
- Briefly press button **1** to increment minutes.
- Briefly press button **2** to decrement minutes.
- » The minutes are set.
- Press and hold button **2** until minutes no longer flash.
- » The clock is set.
- Press and hold button **1** to exit SET CLOCK.
- » SETUP ENTER is displayed.

### Setting the date

- Switching on the ignition (▣▣▣▣ 40).
- Select SETUP (▣▣▣▣ 50).

- Repeatedly short-press button **1** until SET DATE is displayed.
- Press and hold button **2** until day **4** flashes.
- Briefly press button **1** to increment day.
- Briefly press button **2** to decrement day.
- » The day is set.
- Press and hold button **2** until month **3** flashes.
- Briefly press button **1** to increment month.
- Briefly press button **2** to decrement month.
- » The month is set.
- Press and hold button **2** until SET YEAR is displayed.

## 52 OPERATION



- Briefly press button **1** to increment year **5**.
- Briefly press button **2** to decrement year **5**.
- Press and hold button **2** until year no longer flashes.
  - » The year is set.
- Press and hold button **1** to exit SET YEAR.
  - » The date is set.
  - » SETUP ENTER is displayed.

### Setting units

#### Requirement

The vehicle is at a standstill.

- Switching on the ignition (▣▣▣ 40).
- Select SETUP (▣▣▣ 50).



- Briefly press button **1** repeatedly until SET UNIT ENTER is displayed.
- Press and hold button **2** to activate SET UNIT.
  - » UNIT SPEED is displayed.
- Briefly press button **1** in each case to select the parameters in SET UNIT:
  - Change fuel consumption display indicator to L/100, MPG or KM/L
  - Change temperature display unit to °C or °F
  - Change the time display to 24H or 12H
  - Change date format to DMY or MDY

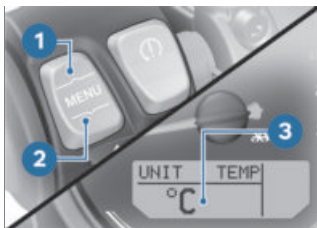

- Briefly press button **2** until each desired unit **3** is set.
  - If you want to complete the configuration, press button **1** repeatedly until SET UNIT EXIT is displayed.
  - Press and hold button **2** to exit SET UNIT.
- » SETUP RESET is displayed.

» The display SET UNIT EXIT will be shown.

- Press and hold button **2** to exit SET UNIT.

» SETUP RESET is displayed.

### Resetting SETUP

- Turn on the ignition.
- Select SETUP (▶▶▶ 50).



- Briefly press button **1** repeatedly until SETUP RESET is displayed.

- Press and hold button **2** until the RESET display **3** flashes.

 The SETUP RESET function also resets the date and time to their standard values.

» SETUP EXIT is displayed.

- Exiting SETUP (▶▶▶ 53).



- If you want to reset the units to the factory setting, press button **1** repeatedly until SET UNIT RESET is shown.
  - Press and hold button **2** until the RESET display **3** flashes.
- » The units have been reset to the factory setting.

### Exiting SETUP Requirement

There are four ways to exit SETUP.

## 54 OPERATION

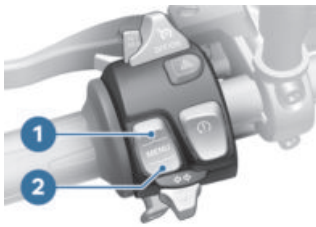

- Press and hold button **1**.
  - » **SETUP ENTER** is displayed.
  - » Settings have been saved.
- Alternative method: Briefly press button **1** repeatedly until **SETUP EXIT** is displayed.
- Press and hold button **2**.
  - » **SETUP ENTER** is displayed.
  - » Settings have been saved.
- Alternative method: Turn the ignition off and on again.
  - » **SETUP** ends without saving the settings.
- Alternative method: Driving off.



Speed for using **SETUP**

max 6 mph (max 10 km/h)

- » When the permissible speed for operation is exceeded, **SETUP** ends without saving the settings.
- » **MI** is displayed.

### ANTI-THEFT ALARM SYSTEM (DWA)

–with anti-theft alarm system (DWA)<sup>OE</sup>

#### Activating the DWA

- Switching on the ignition (▮▮▮▮▶ 40).
- Setting the DWA (▮▮▮▮▶ 55).
- Switch off the ignition.
  - » If the DWA is activated, the DWA will automatically be activated after the ignition is switched off.
  - » Activation takes approximately 30 seconds to complete.
- Turn signals are illuminated twice.
- » DWA is armed.

#### Alarm signal

The DWA alarm can be set off by:

- Motion sensor
- Switching on ignition with an unauthorized ignition key.
- Disconnecting the DWA from the motorcycle battery (DWA battery takes over the power supply – alarm sound only, hazard warning lights do not flash).

If the DWA battery is discharged all functions remain operational; the only difference is that the alarm cannot be set off if the system is disconnected from the motorcycle battery.

The duration of the alarm signal is approx. 26 seconds. During the DWA alarm, an alarm tone sounds and the indicators flash. The type of alarm sound can be set by an authorized BMW Motorrad retailer.

If a DWA alarm was activated while the motorcycle was unattended, the driver is notified accordingly by an alarm tone sounding once when the ignition is switched on. The DWA LED then indicates the reason for the DWA alarm for one minute.

#### Light signals on DWA LED:

- 1 flash: motion sensor 1
- 2 flashes: motion sensor 2
- 3 flashes: ignition turned on with unauthorized ignition key
- 4 flashes: DWA disconnected from motorcycle battery
- 5 flashes: motion sensor 3

#### Deactivating the DWA

- Switching on the ignition (▶▶▶▶ 40).
- » Turn indicators are illuminated once.
- » DWA is switched off.

#### Setting the DWA

- Switching on the ignition (▶▶▶▶ 40).
- Select SETUP (▶▶▶▶ 50).



- Briefly press button **1** repeatedly until SET DWA is displayed.
- Briefly press button **2** to change the adjusted value. The following settings are available:
  - DWA ON: DWA is activated or is activated automatically when the ignition is switched off.
  - DWA OFF: DWA is deactivated.
- Press and hold button **1** to exit SET DWA.
  - » SETUP ENTER is displayed.

## 56 OPERATION

### TRACTION CONTROL (ASC/DTC)

#### Switching off the ASC/DTC function

- Switching on the ignition (→ 40).

 The ASC/DTC function can also be deactivated while you are riding.



- Press and hold button **1** until the ASC/DTC indicator and warning light **2** changes its display behavior.

 starts to light up.

» The ASC/DTC function is switched off.

#### Switching on the ASC/DTC function



- Press and hold button **1** until the ASC/DTC indicator and warning light **2** changes its display behavior.

 goes out, and if self-diagnosis has not been completed, it begins to flash.

» The ASC/DTC function is switched on.

- As an alternative, the ignition can also be switched off and then on again.

 If the ASC/DTC indicator and warning light do not go dark after the ignition has been switched off and then on again and riding has continued after this at the following minimum speed, an ASC/DTC fault has occurred.

min 3 mph (min 5 km/h)

- For more information on ASC/DTC traction control,

see Chapter "Technology in detail" (▣▶ 101).

## RIDING MODE

### Use of the riding modes

BMW Motorrad has developed riding scenarios for your motorcycle from which you can select the one matching your situation:

#### Standard

- RAIN: Riding on roads that are slick from rain.
- ROAD: Riding on dry roads.

-with riding modes Pro<sup>OE</sup>

#### Also with Pro riding modes

- DYNA: Dynamic riding on dry roads.

The optimum interaction between engine characteristics, ABS control, and ASC/DTC control is provided for each of these scenarios.

More detailed information about the riding modes can be found in the "Technology in detail" Chapter (▣▶ 103).

### Select riding mode

- Switching on the ignition (▣▶ 40).



- Press button **1**.
- » The current riding mode **2** is displayed.



- Press button **1** repeatedly until the desired riding mode **2** is displayed.
- » When the vehicle is at a standstill, the selected riding mode is activated after approx. 2 seconds.
- » The new riding mode is activated while the motorcycle is in motion under the following conditions:
  - The throttle grip is in neutral.
  - Brake is not engaged.

## 58 OPERATION

- with speed control<sup>OE</sup>
- » Additionally, for vehicles with adaptive cruise control:
  - Adaptive cruise control is deactivated.◁
  - » The riding mode that is set and its corresponding adjustments of engine characteristics and ABS control and ASC/DTC control are retained even after the ignition is switched off.

### ADAPTIVE CRUISE CONTROL

–with speed control<sup>OE</sup>

#### Switching on the adaptive cruise control



- Slide switch **1** to the right.
- » Button **2** is unlocked.

#### Storing speed



- Briefly push button **1** forward.

 Adjustment range of the adaptive cruise control (gear-dependent)

12...130 mph (20...210 km/h)



Icon for adaptive cruise control is displayed.

- » The motorcycle maintains your current cruising speed and the setting is saved.

#### Accelerating

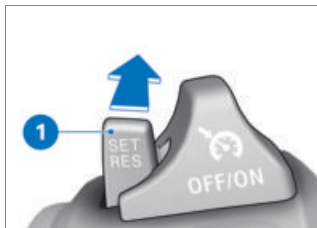

- Briefly push button **1** forward.
- » Speed is increased by 1 mph (1.6 km/h) each time the button is pressed.



- Press button **1** forward and hold.
  - » The speed increases steplessly.
  - » If button **1** is no longer pressed, the speed reached is maintained and saved.

### Decelerating

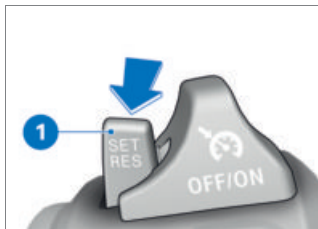

- Briefly press button **1** backward.
  - » Speed is reduced by 1 mph (1.6 km/h) each time the button is pressed.
- Press button **1** back and hold.
  - » The speed is reduced continuously.
  - » If button **1** is no longer pressed, the speed reached is maintained and saved.

### Deactivating the adaptive cruise control

- Actuate the brakes, coupling or throttle grip (ease the throttle beyond the default setting) to deactivate the adaptive cruise control.

 During ASC/DTC interventions, the adaptive cruise control is automatically deactivated for safety reasons.

- » Icon for adaptive cruise control disappears.

### Resuming previous cruising speed



- Briefly push button **1** back to return to the speed saved beforehand.

 Cruise control is not deactivated by accelerating. If you release the throttle grip, the motorcycle will decelerate only to the cruising speed saved in memory, even though you might have wanted to slow down to a lower speed.

 Icon for adaptive cruise control is displayed.

## 60 OPERATION

### Switching off the adaptive cruise control

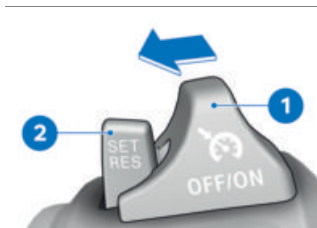



- Push switch **1** to the left.
  - » The system is switched off.
  - » Button **2** is locked.

### HEATED GRIPS

—with heated grips<sup>OE</sup>

#### Operating heated grips

 The heated grips option can only be activated when the engine is running.

 The increase in power consumption caused by the heated grips can drain the battery if you are riding at low engine speeds. If the battery is inadequately charged, the heated grips are switched off to ensure starting capability.

- Starting the engine ( 83).



- Press button **1** repeatedly until desired heating level **2** is displayed.

The following settings are available:



Heating off



Low heater output



High heater output

- » High heater output is used for fast heating of the grips; the switch should then be switched back to a lower heater output.
- » If no further changes are made, the selected heating level is set and the heated grip icon is hidden.

## RIDER SEAT AND PASSENGER SEAT

### Removing the rider's seat

- Removing passenger seat (→ 61).

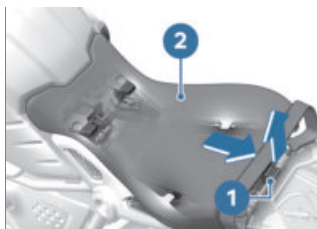

- Pull locking mechanism **1** upwards.
- Pull rider's seat **2** toward rear and remove.

### Installing rider's seat

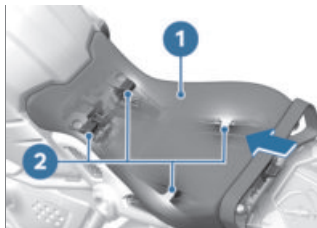

- Insert rider's seat **1** in the tabs **2**.
- Press down firmly on rear region of rider's seat **1**.  
» Rider's seat engages audibly.
- Installing the passenger seat (→ 61).

### Removing passenger seat

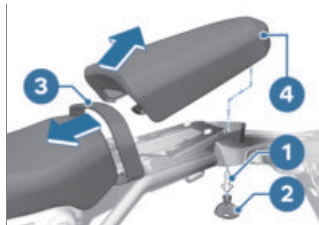

- Remove the screw **1** with the motorcycle seat key **2**.
- Pull grab strap **3** in direction of rider's seat and remove passenger seat **4** toward rear.

### Installing the passenger seat

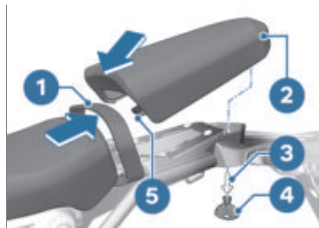

- Insert passenger seat **2** in rear frame – make sure that lug **5** of passenger seat is seated in rear frame.
- Hand-tighten the screw **3** with the motorcycle seat key **4**.
- Pull grab strap **1** over passenger seat.

**SETTING**

**05**

---

<b>MIRRORS</b>	<b>64</b>
<b>HEADLIGHT</b>	<b>65</b>
<b>CLUTCH</b>	<b>66</b>
<b>BRAKE</b>	<b>67</b>
<b>SPRING PRELOAD</b>	<b>68</b>
<b>DAMPING</b>	<b>70</b>
<b>FOOTREST SYSTEM</b>	<b>72</b>

## 64 SETTING

### MIRRORS

#### Adjusting mirrors



- Move mirror into desired position by twisting.

—with Option 719 Milled Parts Set Classic II<sup>OE</sup>

or

—with Option 719 Milled Parts Set Shadow II<sup>OE</sup>



#### DANGER

#### Function impaired by incorrect installation position

Risk of a fall or accident

- Do not change the installation position of the mirror.

- Move mirror body into desired position by twisting it.◀

#### Adjusting mirror arm



- Slide protective cap up over screw connection on mirror arm.
- Loosen nut **1** with tool from on-board toolkit.
- Turn mirror arm into desired position.
- Tighten nut **1** while holding mirror arm firmly.



Mirror (locknut) on adapter

16 lb/ft (22 Nm) (Left-hand thread)

- Slide protective cap over screw connection.

## HEADLIGHT

### Headlight adjustment, right-hand/left-hand traffic

This motorcycle's headlight features a symmetrical low beam. No special measures are required prior to operating the motorcycle in a country where traffic travels on the side of the road opposite to that of your home country (left-hand drive to right-hand drive or vice versa).

### Headlight beam throw and spring preload

The headlight beam throw generally remains constant due to the adjustment of the spring preload to the load status. However, in the case of very high payloads, the available spring preload adjustment might not be adequate. If that is the case, the headlight beam throw must be adapted to the weight.

 If there are doubts as to the correct headlight range, have the adjustment checked by a specialized workshop, preferably by an authorized BMW Motorrad retailer.

### Adjusting the headlight beam throw

#### Requirement

Despite adjusting the spring preload, the high payload means that oncoming traffic is blinded.

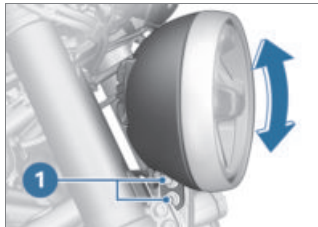

- Slacken screws **1**.
- Swivel the headlight to adjust the headlight range.
- Tighten screw **1** while holding the headlight.



Headlight on bracket

14 lb/ft (19 Nm)

If the motorcycle is ridden again with lower payload:

- Have the headlight base setting readjusted by a specialist workshop, preferably an authorized BMW Motorrad retailer.

## 66 SETTING

### CLUTCH

#### Adjusting the clutch lever



#### WARNING

##### Modified position of the clutch fluid reservoir

Air in the clutch system

- Do not twist the handlebar fitting or the handlebars.



#### WARNING

##### Adjusting the clutch lever while driving

Accident hazard

- Adjust the clutch lever when the motorcycle is stationary.

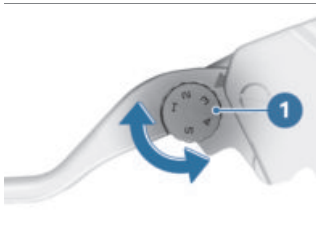

- Turn the adjustment screw **1** into the desired position by applying gentle pressure from the rear.

 The adjusting screw is easier to turn when the clutch lever is pressed forward.

» Adjustment options:

- From position 1: Smallest distance between handlebar grip and clutch lever
- To position 5: Largest distance between handlebar grip and clutch lever
- with Option 719 Milled Parts Set Classic II<sup>OE</sup> or
- with Option 719 Milled Parts Set Shadow II<sup>OE</sup>

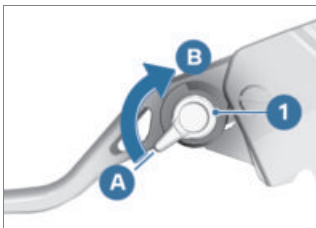

- Turn the adjustment lever **1** to the desired position.
- » Adjustment options:
  - From position **A**: smallest distance between handlebar grip and clutch lever.
  - Five steps toward position **B** to increase the distance between the handlebar grip and the clutch lever. ◁



**BRAKE****Adjusting the brake lever****WARNING****Modified position of the brake fluid reservoir**

Air in the brake system

- Do not twist the handlebar fitting or the handlebars.

**WARNING****Adjusting the brake lever while driving**

Risk of accident

- Do not attempt to adjust the brake lever unless the motorcycle is at a standstill.

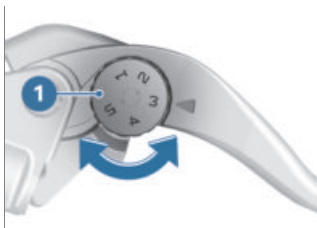

- Turn the adjustment screw **1** into the desired position by applying gentle pressure from the rear.

 The adjustment screw is easier to turn when the brake lever is pressed forward.

» Adjustment options:

- From position **1**: Smallest distance between handlebar grip and brake lever
- To position **5**: Greatest distance between handlebar grip and brake lever
- with Option 719 Milled Parts Set Classic II<sup>OE</sup>
- or
- with Option 719 Milled Parts Set Shadow II<sup>OE</sup>

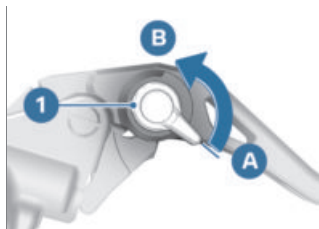

- Turn the adjustment lever **1** to the desired position.
- » Adjustment options:
- From position **A**: smallest distance between handlebar grip and handbrake lever.
- Five steps toward position **B** to increase the distance between the handlebar grip and the handbrake lever.◀

## 68 SETTING

### SPRING PRELOAD

#### Adjustment to front wheel

The spring preload on the front wheel must be adapted to the weight of the rider. Higher weight requires a higher spring preload, lower weight requires a lower spring preload.

#### Adjusting the spring preload on the front wheel

- Park the motorcycle, making sure that the ground is firm and level.
- Make sure there is no load on the motorcycle – remove any items of luggage as necessary.

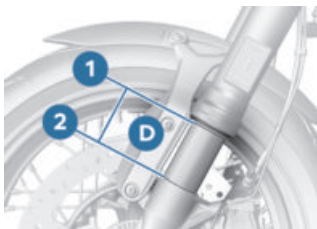

- Hold the motorcycle vertically and measure the spacing **D** between the lower edge **1** of the slider tube and the point **2**.
- Have the rider put their weight on the motorcycle.
- With the assistance of a helper, measure the

distance **D** between points **1** and **2** again and calculate the difference (compression) between the measured values.

Adjustment of spring preload dependent on loading

Compressing front wheel

0.24...0.39 in (6...10 mm)  
(With rider 187 lbs (85 kg))

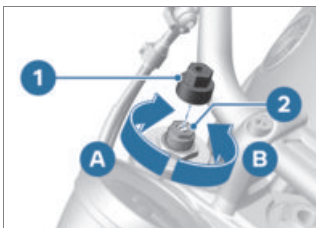

- Fit the plastic top part **1** from the onboard vehicle tool kit on the adjustment screws **2**.

#### **WARNING**

**Uncoordinated settings of spring preload and spring strut damping.**

Poorer handling.

- Adjust damping characteristic to changed spring preload.
- To lower the compression (increase the spring preload), turn the adjustment screws **2**

in direction **A** using the on-board vehicle tool kit.

- To increase the compression (reduce the spring preload), turn the adjustment screws **2** in direction **B** using a tool from the onboard vehicle tool kit.
- Make sure that the same values are set on the left and right.

### Adjustment on rear wheel

It is essential to set the spring preload at the rear wheel to suit the load carried by the motorcycle. Increase spring preload if the payload increases and reduce spring preload accordingly if the payload decreases.

### Adjusting the spring preload at the rear wheel

- Park the motorcycle, making sure that the ground is firm and level.

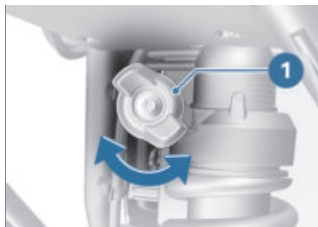

### WARNING

#### Uncoordinated settings of spring preload and spring strut damping.

Poorer handling.

- Adjust damping characteristic to changed spring preload.
  - To increase spring preload, turn adjustment wheel **1** clockwise.
  - To decrease spring preload, turn adjustment wheel **1** counterclockwise.
  - Adjust the damping to the changed spring preload.
-  A recommendation on the chassis calibration is provided in the "Technical Data" chapter under "Chassis".
- Adjusting damping at the rear wheel (▮▮▮ 71).

## 70 SETTING

### DAMPING

#### Setting

Damping must be adjusted to the road condition and the spring preload.

- A rough road requires softer damping than a smooth road.
- An increase in spring preload requires firmer damping, a reduction in spring preload requires softer damping.

#### Adjusting the compression damping on the front wheel

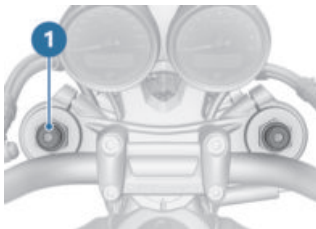

- Adjust compression damping with adjusting screw **1** on the left-side fork leg.



- To increase damping: Turn adjustment screw with tool from onboard vehicle tool kit so that the mark **1** points to a higher scale value.
- To decrease damping: Turn adjustment screw with tool from onboard vehicle tool kit so that the mark **1** points to a lower scale value.



Compression stage, basic setting, front

Position 1 (comfortable setting with rider 187 lbs (85 kg))

Position 3 (standard setting with rider 187 lbs (85 kg))

Position 7 (sport-oriented setting with rider 187 lbs (85 kg))

## Adjusting the rebound-stage damping on front wheel



- Adjust rebound-stage damping by means of the adjustment screw **1** on the right-side fork leg.



- To increase damping: Turn adjustment screw with tool from onboard vehicle tool kit so that the mark **1** points to a higher scale value.
- To decrease damping: Turn adjustment screw with tool from onboard vehicle tool kit so that the mark **1** points to a lower scale value.



Rebound stage, basic setting, front

Position 1 (comfortable setting with rider 187 lbs (85 kg))

Position 3 (standard setting with rider 187 lbs (85 kg))

Position 7 (sport-oriented setting with rider 187 lbs (85 kg))

## Factory settings at front wheel

- Use following specification data to adjust to factory settings.



Factory settings for jounce/rebound at front

Position 3

## Adjusting damping at the rear wheel

- Park the motorcycle, making sure that the ground is firm and level.

## 72 SETTING

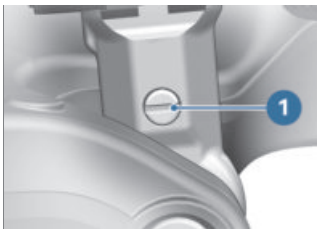

### CAUTION

#### Adjusting the spring strut damping when the silencer is hot

Burn hazard

- Allow the muffler to cool down.

- To increase damping, turn the adjusting screw **1** clockwise.
- To reduce damping, turn the adjusting screw **1** counter-clockwise.

 A recommendation on the chassis calibration is provided in the "Technical Data" chapter under "Chassis".

### CAUTION

#### Working with hot components

Burn hazard

- Wear protective gloves.

### FOOTREST SYSTEM

–with Option 719 Milled Parts Set Classic II<sup>OE</sup>

or

–with Option 719 Milled Parts Set Shadow II<sup>OE</sup>

- Use on-board toolkit to adjust damping via adjusting screw **1**.

### Adjusting the rotor

### WARNING

**Greater inclinations can lead ground contact of hard components when cornering.**

Accident hazard

- Do not use the footrest as an indicator for critical inclinations.

- The rotor is adjusted in the same way on the left and right.
- The position of the rotor must have the same setting on the right and left.

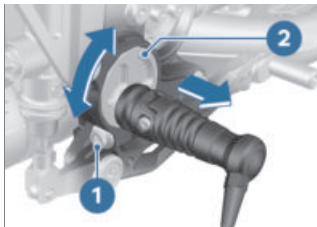

- The foot distance and a higher foot position can be adjusted on the rotor **2**.
- Loosen the bolt **1** far enough that the rotor **2** can be pulled out.
- The rotor **2** is adjustable in 12 positions. To set the highest position, turn the rotor **2** to the left or right by 180°.

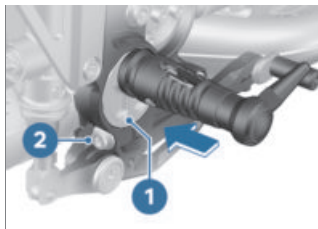

- Install the rotor **1** in the desired position and tighten the screw **2**.



Rotor on base plate

15 lb/ft (20 Nm)

**WARNING**

**Incorrectly adjusted footrest due to the rotor being moved.**

Accident hazard

- If the rotor is moved, the footrest adjustment must be adapted accordingly.

- The footrest can only fold upward and slightly backward.

**Adjusting the footrest joint**

- The footrest joint is adjusted in the same way on the left and right.

## 74 SETTING

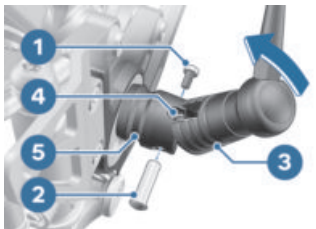

- Remove screw **1** and bolt **2**.
- Fold the footrest body **3** in direction of arrow.  
» The spring is relaxed.
- Disengage spring **4** from footrest joint **5**.

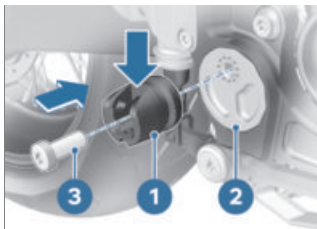

- When ultimately installed on the rotor **2**, the opening **ar-row** of the footrest joint **1** **must** point upward or slightly to the rear and upward.
- Install screw **3**.
- Remove and install the footrest joint on the side of the switch unit in the same way.

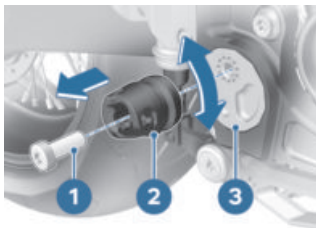

- Remove the screw **1**.
- Pull the footrest joint **2** from the rotor **3**.
- To change the position of the footrest joint **2**, turn it clockwise or counterclockwise.

 Footrest joint on rotor

15 lb/ft (20 Nm)

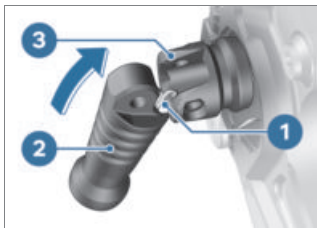

- Attach the spring **1** to the eye on the footrest joint **3**.
- Fold the footrest body **2** upward in the footrest joint **3**.



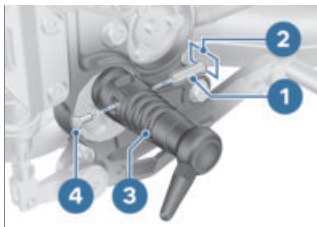

- Install bolt **1** with flattened head **2** flush to the footrest joint and footrest body **3**.
- Install screw **4**.
- Remove and install the footrest body on the side of the switch unit in the same way.

 Footrest body on footrest joint

2 lb/ft (3 Nm)

### Adjusting the footbrake lever foot piece

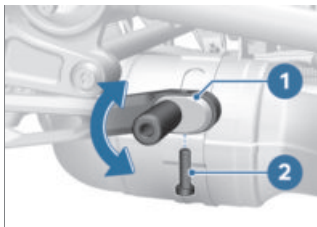

- The horizontal and vertical distance of the foot relative to the foot plate **1** can be ad-

justed by turning it to different positions.

- Remove screw **2**.

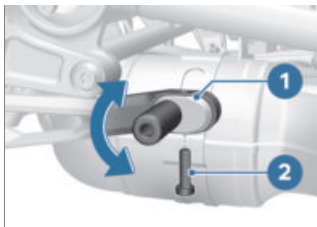

- Clean the thread.
- Turn the foot plate **1** to the desired position.
- Install the **new** screw **2**.

 Foot piece on footbrake lever

Thread-locking compound: micro-encapsulated

7 lb/ft (10 Nm)

### Adjusting gearshift lever foot piece

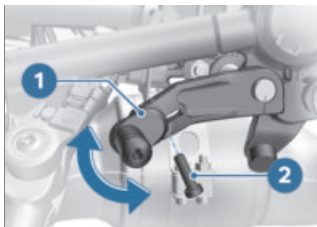

- The horizontal and vertical distance of the foot relative to the foot plate **1** can be ad-

## 76 SETTING

justed by turning it to different positions.

- Remove screw **2**.

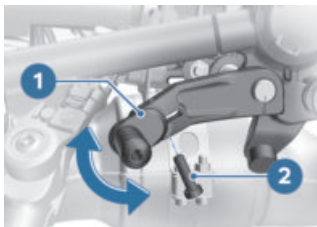

- Clean the thread.
- Turn the foot plate **1** to the desired position.
- Install the **new** screw **2**.

	Foot piece on gearshift lever
Thread-locking compound: micro-encapsulated	
7 lb/ft (10 Nm)	



**RIDING**

**06**

---

<b>SAFETY INSTRUCTIONS</b>	<b>80</b>
<b>REGULAR CHECK</b>	<b>82</b>
<b>STARTING</b>	<b>83</b>
<b>BREAKING IN</b>	<b>86</b>
<b>BRAKES</b>	<b>87</b>
<b>PARKING YOUR MOTORCYCLE</b>	<b>89</b>
<b>REFUELING</b>	<b>90</b>
<b>SECURING MOTORCYCLE FOR TRANSPORTATION</b>	<b>92</b>

# 80 RIDING

## SAFETY INSTRUCTIONS

### Rider's equipment

Do not ride without the correct clothing! Always wear

- Helmet
- Rider's suit
- Gloves
- Boots

This applies even to short journeys, and to every season of the year. Your authorized BMW Motorrad retailer will be happy to advise you and has the correct clothing for every purpose.

### WARNING

#### **Seizure of loose textile fabrics, luggage items or straps in open running rotating vehicle parts (wheels, prop shaft)**

Risk of accident

- Make sure that no loosely worn textile fabrics can get caught in open, running and rotating vehicle parts.
- Keep luggage items as well as tension belts and lashing straps away from open, running and rotating vehicle parts.

## Correct loading

### WARNING

#### **Reduced riding stability caused by overloading and uneven loading**

Accident hazard

- Do not exceed the gross weight limit and observe the loading information.

- Adjust spring preload, suspension damping rate settings and tire inflation pressures for the current gross vehicle weight.
- Pack heavy pieces of luggage and cargo as low and as close to the center of the motorcycle as possible.
- with tank bag<sup>OA</sup>
- Observe maximum payload of tank rucksack.



Payload of tank bag

≤11 lbs (≤5 kg)◁

- with rear bag<sup>OA</sup>

- Observe maximum payload of the rear bag.



Payload of rear bag

max 22 lbs (max 10 kg)◁

## Speed

If you ride at high speed, always bear in mind that various boundary conditions can adversely affect the handling of your motorcycle, e.g.:

- Incorrect adjustment of the spring strut
- Unevenly distributed load
- Loose clothing
- Insufficient tire pressure
- Tire tread in poor condition
- Attached luggage systems, such as a tank bag or rear bag.

## Risk of poisoning

Exhaust gas contains carbon monoxide, which is colorless and odorless but highly toxic.



### WARNING

#### Harmful exhaust gas

Danger of suffocation

- Do not inhale exhaust fumes.
- Do not run the engine in closed rooms.



### WARNING

#### Inhalation of vapors that are harmful to health

Damage to health

- Do not inhale vapors from operating fluids and plastics.
- Only use the vehicle outdoors.

## Burn hazard



### CAUTION

#### Intense heating up of engine and exhaust system while riding

Burn hazard

- After parking the motorcycle, make sure that no persons or objects come into contact with the engine and exhaust system.

## Catalytic converter

There is a danger of overheating and damage if misfiring causes unburned fuel to enter the catalytic converter.

For this reason, observe the following points:

- Do not run the fuel tank dry.
- Do not run the engine with the spark-plug socket removed.
- Stop the engine immediately if it misfires.

## 82 RIDING

- Use unleaded fuel only.
- Comply with all specified maintenance intervals.



### ATTENTION

#### Unburned fuel in the catalytic converter

Damage to catalytic converter

- Note the points listed for protection of the catalytic converter.

### Danger of overheating



### ATTENTION

#### Engine idling for a lengthy period while at a standstill

Overheating due to insufficient cooling; in extreme cases vehicle fire

- Do not allow the engine to idle unnecessarily.
- After starting, ride off immediately.

### Modifications



### ATTENTION

#### Modifications to the motorcycle (e.g. engine control unit, throttle valves, clutch)

Damage to the affected parts, failure of safety-relevant functions, expiration of warranty

- Do not make any modifications.

### REGULAR CHECK

#### Checklist

- Use the following checklist to check your motorcycle at regular intervals.

#### Always before riding off

- Check brake operation (▮▮▮▮▶ 114).
- Check operation of the lighting and signal system.
- Checking clutch function (▮▮▮▮▶ 118).
- Check tire tread depth (▮▮▮▮▶ 119).
- Checking tire pressure (▮▮▮▮▶ 118).
- Check secure hold of luggage systems and luggage.

#### At every third refueling stop

- Checking engine oil level (▮▮▮▮▶ 112).
- Checking the front brake pad thickness (▮▮▮▮▶ 114).



- Checking the rear brake pad thickness (▮▮▮ 115).
- Checking the front brake fluid level (▮▮▮ 116).
- Checking the rear brake fluid level (▮▮▮ 117).

## STARTING

### Starting the engine

- Switching on the ignition (▮▮▮ 40).
  - » ABS self-diagnosis is performed. (▮▮▮ 84)
- Engage neutral, or pull back clutch lever if a gear is engaged.
  -  You cannot start the motorcycle with the side stand extended and a gear engaged. The engine will switch itself off if it is started with the transmission in neutral and then a gear is engaged before retracting the side stand.
- For cold start and in low temperatures:
  - » Pull clutch.



- Press starter button **1**.

 The starting procedure is automatically canceled if the battery voltage is too low. Recharge the battery before you attempt to start the engine again, or use jump-starting. More detailed information can be found in the Maintenance chapter under Jump-starting.

- » Engine starts.
- » Consult the troubleshooting chart if the engine refuses to start. (▮▮▮ 156)

### Pre-Ride-Check

After the ignition is switched on, the instrument cluster performs a test on the instrument dials, the warning and indicator lights, and the display. This is known as the Pre-Ride-Check. Starting the engine before the test is completed will cancel the remainder of the test.

## 84 RIDING

### Phase 1

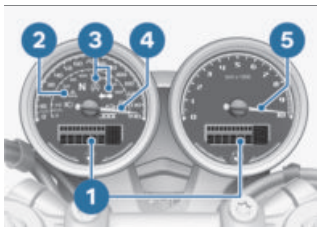

All segments are displayed in the displays **1**.

At the same time, all indicator and warning lights **3** are switched on.

### Phase 2

The general warning light **2** changes from being continuously lit to flashing.

The needle **4** for the speedometer moves to maximum speed.

The needle **5** for the RPM moves to maximum RPM.

### Phase 3

The needle **4** for the speedometer moves to zero.

The needle **5** for the RPM drops to zero.

The indicator and warning lights go out or adopt their functions for operation.

The display reverts to the standard format. The onboard computer is displayed.

If the needles did not move, an indicator and warning light was not switched on, or segments are missing in the display:

- Have the malfunction corrected as soon as possible at a specialist workshop, preferably an authorized BMW Motorrad retailer.

### ABS self-diagnosis

The self-diagnosis routine is determining whether BMW Motorrad ABS is ready for operation. The self-diagnosis starts automatically when you start the ignition.

#### Phase 1

- » Check system components capable of diagnosis while vehicle is at a standstill.



flashes.

#### Phase 2

- » Check wheel speed sensors while riding off.



flashes.

### ABS self-diagnosis completed

- » The ABS indicator and warning light goes out.



ABS self-diagnosis routine not completed

ABS is not available, as the self-diagnosis routine was not completed. (The motorcycle must reach a specified minimum speed before the system can check operation of the wheel speed sensors: 3 mph (5 km/h))

If an ABS error is displayed after the ABS self-diagnosis is completed:

- You may continue riding. It must be noted that the ABS function is not available.
- Have the malfunction corrected as soon as possible at a specialist workshop, preferably an authorized BMW Motorrad retailer.

### ASC self-diagnosis

The self-diagnosis routine checks whether the BMW Motorrad ASC is ready for operation. The self-diagnosis routine runs automatically when you switch on the ignition.

#### Phase 1

- » Check on system components monitored by the diagnostic system while vehicle is parked.



flashes.

#### Phase 2

- » Checking the diagnosable system components while the motorcycle is moving.



flashes.

### ASC self-diagnosis completed

- » The ASC indicator and warning light goes out.
- Check the display of all indicator and warning lights.



ASC self-diagnosis routine not completed

ASC is not available because the self-diagnosis routine was not completed. (The motorcycle must reach a specified minimum speed before the system can check operation of the wheel sensors: min 3 mph (min 5 km/h))

If an ASC error is displayed after the ASC self-diagnosis is completed:

- It remains possible to continue riding. It must be noted that the ASC function is not available.
- Have the malfunction corrected as soon as possible at an authorized service facility.

## 86 RIDING

ity, preferably an authorized BMW Motorrad Retailer.

### DTC self-diagnosis

—with riding modes Pro<sup>OE</sup>

The self-diagnosis routine is determining whether BMW Motorrad DTC is ready for operation. The self-diagnosis runs automatically when you switch on the ignition.

#### Phase 1

» Checking system components capable of diagnosis while vehicle is at a standstill.



DTC indicator and warning light flashes slowly.

#### Phase 2

» Checking system components capable of diagnosis while riding off.



DTC indicator and warning light flashes slowly.

### DTC self-diagnosis completed

» The DTC symbol is no longer displayed.

- Check the display of all indicator and warning lights.



DTC self-diagnosis not completed

The DTC function is not available, as the self-diagnosis function has not been completed. (To check wheel speed sensors, motorcycle must reach a minimum speed with engine running: min 3 mph (min 5 km/h))

If a DTC fault is displayed after the DTC self-diagnosis is completed:



- You may continue riding. Please note that the DTC function is restricted or is not available at all.
- Have the malfunction corrected as soon as possible at a specialist workshop, preferably an authorized BMW Motorrad retailer.

---

## BREAKING IN

### Engine

- While running in the motorcycle, vary the throttle opening and engine-speed range frequently; avoid driving for long periods at a constant speed.
- Choose curvy, slightly hilly sections of road if possible.
- Observe the engine run-in speeds.

	Engine run-in speed
	<5000 min <sup>-1</sup> (Mileage 0...621 miles (0...1000 km))
	• Observe mileage, after which the running-in check should be performed.
	Mileage until first running-in check
	311...746 miles (500...1200 km)

### Brake pads

New brake pads have to be broken in before they can achieve their optimum frictional force. This initial reduction in braking effect can be compensated for by exerting greater pressure on the brake levers.



### WARNING

#### New brake pads

Extension of the braking distance, accident hazard

- Brake early.

### Tires

New tires have a smooth surface. This must be roughened by riding in a restrained manner at various heel angles until the tires are run in. This running in procedure is essential

if the tires are to achieve maximum grip.



### WARNING

#### Loss of adhesion of new tires on wet roads and at extreme angles

Accident hazard

- Always think well ahead and avoid extreme angles.

## BRAKES

### How do you achieve the shortest braking distance?

The dynamic load distribution between the front and rear wheel changes during braking. The heavier you brake, the greater the weight transfer to the front wheel. Increases in the load on an individual wheel are accompanied by a rise in the effective brake force that the wheel can provide. To achieve the shortest possible braking distance, the front wheel brake must be applied quickly and with progressively greater levels of force. This procedure provides ideal utilization of the dynamic load increase to the front wheel. The clutch should also be engaged at the same time. When the rider uses the

## 88 RIDING

(frequently practiced) extreme emergency braking in which the brake pressure is generated as quickly as possible and with great force, dynamic load distribution lags behind the progressive increase in deceleration rate and the brake force cannot be completely transferred to the road. Locking up of the front wheel is prevented by BMW Motorrad ABS.



### WARNING

#### **Lifting off of the rear wheel due to heavy braking**

Accident hazard

- When braking heavily, bear in mind that the ABS control cannot always be relied on to prevent the rear wheel from lifting off the ground.

### Descending mountain passes



### WARNING

#### **Braking should be done predominantly using the rear wheel brake when riding on downhill routes**

Loss of braking effect, destruction of the brakes due to overheating

- Apply the front and rear wheel brake and use the engine brake.

#### **Wet, soiled brakes**

Moisture and dirt on the brake discs and the brake pads result in a decrease in the braking effect.

Delayed or poorer braking effect must be expected in the following situations:

- When driving in the rain and through puddles.
- After washing the motorcycle.
- When driving on roads spread with salt.
- After working on the brakes due to oil or grease residues.
- When driving on soiled roads or offroad.

**WARNING****Poorer braking action due to moisture and dirt**

Accident hazard

- Brake until brakes are dry or clean; clean if necessary.
- Brake early until the full braking action is available again.

**ABS Pro****Physical riding limits****WARNING****Braking in curves**

Danger of falling despite ABS Pro

- The rider is always responsible for adapting his/her driving style.
- Do not reduce the system's extra safety margin with careless riding or unnecessary risks.

**Falling cannot be excluded**

Although ABS Pro and Dynamic Brake Control represent valuable support and an enormous safety advantage for the rider when braking in an inclined position, they by no means redefine the physical riding limits. It is still possible to exceed those limits through

misjudgments or riding errors. In extreme cases this may result in a fall.

**Use on public roads**

ABS Pro and Dynamic Brake Control help make riding your motorcycle on public roads even safer. When braking due to unexpected hazards in curves, ABS Pro prevents blocking and slipping of the wheels within the scope of the physical riding limits.

In the event of emergency braking, Dynamic Brake Control enhances the braking effect and intervenes if the throttle grip is accidentally actuated during braking.



ABS Pro was not developed to increase the individual braking performance in the inclined position.

**PARKING YOUR MOTORCYCLE****Side stand**

- Switch off engine.

## ATTENTION

### Poor ground conditions in area of stand

Component damage caused by tipping over

- Always check that the ground under the stand is level and firm.

## ATTENTION

### Loading of the side stand with additional weight

Component damage caused by tipping over

- Do not sit on the motorcycle when it is parked on the side stands.
- Fold out side stand and park motorcycle.
- If the slope of the road permits, turn the handlebars to the left.
- On slopes point the motorcycle uphill and engage 1st gear.

## REFUELING

### Fuel grade Requirement

For optimal fuel consumption, the fuel should be sulfur-free or very low in sulfur content.

## ATTENTION

### Refueling with leaded fuel

Damage to catalytic converter

- Do not refuel with leaded gasoline or gasoline with metallic additives, e.g. manganese or iron.



## ATTENTION

### Use of Ethanol E85 as fuel

Damage to the engine and fuel supply

- Do not refuel with E85, i.e. fuel with an ethanol content of 85 %, or with Flex Fuel.
  - Fuels with a maximum ethanol content of 15 %, i.e. E15, may be used for refueling.
-  Fuel additives clean the fuel injection system and the combustion area. Fuel additives should be used when refueling with low-quality fuels or during longer periods of downtime. Your authorized BMW Motorrad retailer can provide you with more detailed information.



	Recommended fuel quality
	Super unleaded (max. 15% ethanol, E15) 89 AKI (95 ROZ/RON) 90 AKI
	Alternative fuel quality
	Regular unleaded (max. 15% ethanol, E15) 87 AKI (91 ROZ/RON) 87 AKI

### Refueling procedure



#### WARNING

##### Fuel is highly flammable

Fire and explosion hazard

- Do not smoke. Never bring a naked flame near the fuel tank.



#### ATTENTION

##### Component damage

Component damage due to overfilled fuel tank

- If the fuel tank is overfilled, the excess fuel will flow into the carbon canister and lead to component damage there.
- Only fill the fuel tank to the lower edge of the fuel filler neck.



#### ATTENTION

##### Contact of fuel and plastic surfaces

Damage to surfaces (become unattractive or cloudy)

- Immediately clean plastic surfaces after contact with fuel.
- Park the motorcycle, making sure that the ground is firm and level.

## 92 RIDING

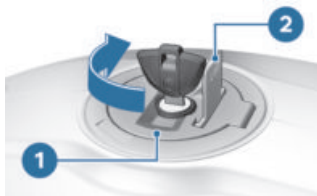

- Open the protective cap **2**.
- Unlock the fuel tank cap **1** in a clockwise direction using the ignition key and fold it up.

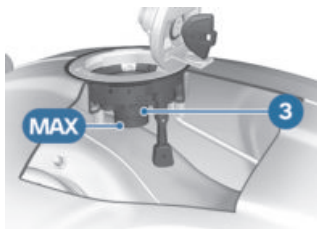

- Refuel with a fuel meeting the specifications below, continuing until fuel is no higher than lower edge of the filler neck.

 If refueling is carried out after running on fuel reserve, the resulting filling capacity must be greater than the fuel reserve so that the new fill level is detected and the fuel reserve indicator light is switched off.

 The "usable fuel quantity" specified in the technical data is the fuel quantity, which can be refueled if the fuel tank was completely emptied, i.e., if the engine dies off due to lack of fuel.



Usable fuel quantity

Approx. 4.8 gal (Approx. 18 l)



Reserve fuel quantity

Approx. 3.7 quarts (Approx. 3.5 l)

- Press fuel tank cap down firmly to close.
- Remove key and close protective cap.

### SECURING MOTORCYCLE FOR TRANSPORTATION

- Protect all component surfaces against which tensioning straps are routed against scratching. For example, use adhesive tape or soft cloths.



### ATTENTION

#### Motorcycle tips to the side when raising

Component damage cause by tipping over

- Secure the motorcycle against tipping to the side, preferably with the assistance of a second person.
- Push motorcycle onto transport surface, and do not place on side stand.

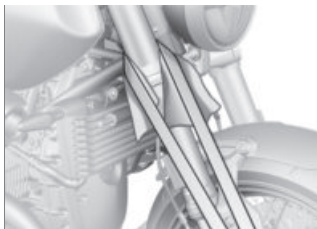

### ATTENTION

#### Pinching of components

Component damage

- Do not pinch components, e.g. brake lines or wiring harnesses.
- Fasten the front tensioning straps on both sides of the fork bridge at the bottom.

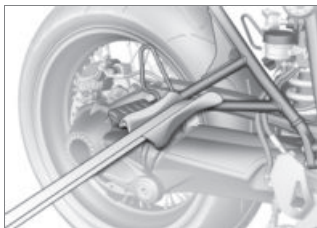

- Fasten rear straps on both sides to the brackets of the passenger footrests and then tighten them.
- Tighten all tensioning straps evenly.

## **94 RIDING**

- » The vehicle is lashed down securely (suspension is compressed).



# **TECHNOLOGY IN DETAIL**

**07**

---

<b>GENERAL NOTES</b>	<b>98</b>
<b>ANTI-LOCK BRAKING SYSTEM (ABS)</b>	<b>98</b>
<b>DYNAMIC BRAKE CONTROL</b>	<b>101</b>
<b>TRACTION CONTROL (ASC/DTC)</b>	<b>101</b>
<b>RIDING MODE</b>	<b>103</b>
<b>DYNAMIC ENGINE BRAKE CONTROL</b>	<b>105</b>
<b>ADAPTIVE HEADLIGHTS</b>	<b>106</b>

## 98 TECHNOLOGY IN DETAIL

---

### GENERAL NOTES

More information on the topic of technology is available at: [bmw-motorrad.com/technology](http://bmw-motorrad.com/technology)

---

### ANTI-LOCK BRAKING SYSTEM (ABS)

#### How does ABS work?

The maximum braking force that can be transferred to the road is partially dependent on the coefficient of friction of the road. Gravel, ice, snow and wet roads offer a considerably lower coefficient of friction than a dry, clean asphalt surface. The poorer the coefficient of friction of the road is, the longer the braking distance will be.

If the maximum transferable brake pressure is exceeded when the driver increases the brake pressure, the wheels begin to lock and driving stability is lost; this could result in a fall. Before this situation occurs, ABS is activated and the brake pressure is adjusted to the maximum transferable braking force. This enables the wheels to continue to turn and maintains driving stability regardless of the road surface condition.

#### What happens when rough roads are encountered?

Rough roads can briefly lead to a loss of contact between the tires and the road surface. The transferable braking force is then reduced to zero. If braking is carried out in this situation, ABS must reduce the brake pressure to ensure driving stability when restoring contact to the road. At this point in time, ABS must assume extremely low friction coefficients (gravel, ice, snow) so that the wheels turn in every imaginable case and driving stability is ensured. After detecting the actual conditions, the system adjusts the optimum brake pressure.

#### Lifting off rear wheel

During extremely heavy and rapid decelerations it is possible that the BMW Motorrad ABS cannot prevent the rear wheel from lifting off the ground. In these cases, the motorcycle can also flip end over end.



**WARNING****Lifting off of the rear wheel due to heavy braking**

Accident hazard

- When braking heavily, bear in mind that the ABS control cannot always be relied on to prevent the rear wheel from lifting off the ground.

**What are the design characteristics of the BMW Motorrad ABS?**

The BMW Motorrad ABS ensures riding stability on any surface within the limits of riding physics.

From a speed greater than 2.5 mph (4 km/h), the BMW Motorrad ABS can ensure riding stability on any surface within the limits of riding physics. At lower speeds, the BMW Motorrad ABS cannot provide optimal support on all surfaces due to system limitations.

The system is not optimized for the special conditions encountered under the extreme conditions of competitive off-road and race-track use.

**Special situations**

To detect the tendency of the wheels to lock up, the speeds of the front and rear wheel are compared. If implausible values are detected over a longer period of time, the ABS function is deactivated for safety reasons and an ABS error is indicated. A self-diagnosis routine must be completed before the error will be displayed.

Apart from problems with the BMW Motorrad ABS, unusual riding conditions can also cause a fault message to be generated:

- Driving on the rear wheel (wheelie) for a longer period.
- Rear wheel spinning in place with front brake engaged (burn out).
- Warm-up on the center or auxiliary stand at idle or with gear engaged.
- Locked-up rear wheel for a longer period of time, e.g. when riding downhill offroad.

Should a fault code occur due to an unusual driving condition, the ABS function can be reactivated by switching the ignition off and then on again.

## How important is regular maintenance?



### WARNING

#### Brake system not regularly serviced

Accident hazard

- To ensure that the BMW Motorrad ABS is in a properly maintained condition, it is vital that the specified service intervals are kept to.

#### Reserves for safety

The potentially shorter stopping distances which BMW Motorrad ABS permits must not be used as an excuse for careless riding. ABS is primarily a means of ensuring a safety margin in genuine emergencies.



### WARNING

#### Braking in curves

Risk of accident despite ABS

- The rider is always responsible for adapting his/her driving style.
- Do not reduce the additional safety function with careless riding or unnecessary risks.

#### ABS Pro

ABS Pro increases safety, in particular when braking in corners. ABS Pro stops the wheels from locking up, even if the brakes are actuated quickly. ABS Pro reduces abrupt changes in steering forces, especially during shock braking, and therefore decreases the risk of an undesirable "rearing up" of the vehicle.

#### ABS control

From a technical standpoint, ABS Pro adjusts the ABS control to the angle of inclination of the motorcycle in dependence on the respective riding situation. Signals for the roll and yaw rate and the lateral acceleration are used to determine the inclination of the motorcycle. The signals come from the angular rate sensor, which is already used for Dynamic Traction Control DTC.

With an increasing inclination, the brake pressure gradient is increasingly limited at the start of braking. This results in a slower pressure buildup. In addition, the pressure modulation in the range of the ABS control is more uniform.

**Advantages for the rider**

The advantages of ABS Pro for the rider are sensitive response and high braking and riding stability with the best possible deceleration, even in curves.

---

**DYNAMIC BRAKE CONTROL**

–with riding modes Pro<sup>OE</sup>

**Dynamic Brake Control function**

The Dynamic Brake Control function helps the rider in the event of emergency braking.

**Detection of emergency braking**

–Emergency braking is detected when the front wheel brake is applied quickly and with force.

**Behavior during emergency braking**

–If emergency braking is applied at a speed of more than 10 km/h, in addition to the ABS function, the Dynamic Brake Control function will also be activated.

**Behavior in the event of accidental activation of the throttle grip**

–If the throttle grip is accidentally actuated during emergency braking (throttle position >5%), the intended brak-

ing effect is ensured by the Dynamic Brake Control ignoring the opening process of the throttle grip. This ensures the effectiveness of emergency braking.

- If the gas is shut off (throttle position <5%) during the intervention of the Dynamic Brake Control, the engine torque required by the ABS brake system will be restored.
- If the emergency braking is stopped and the throttle grip is still under actuation, the Dynamic Brake Control reduces the engine torque as required by the rider in a controlled manner.

---

**TRACTION CONTROL (ASC/DTC)****How does traction control work?**

Traction Control is available in two versions

- Without** taking the angle into account: Automatic Stability Control ASC
- ASC is a rudimentary function intended to prevent falls.
- With** taking the angle into account: Dynamic Traction Control DTC
- The additional inclined position and acceleration informa-

## 102 TECHNOLOGY IN DETAIL

tion enables the DTC to make more precise and comfortable adjustments.

The traction control compares the wheel circumferential velocities of the front and rear wheel. The slip, and with it the stability reserves at the rear wheel, are determined from the speed difference. The engine control adapts the engine torque when the slip limit is exceeded.

The BMW Motorrad ASC/DTC is designed as an assistance system for the rider and for riding on public roads. The extent to which the rider affects ASC/DTC control can be considerable (weight shifts when cornering, loose luggage on the motorcycle), especially when approaching the limits imposed by the laws of physics.

The system is not optimized for the special conditions encountered under the extreme conditions of competitive off-road and racetrack use. The BMW Motorrad ASC/DTC can be switched off in such instances.



### WARNING

#### Risky riding style

Accident hazard despite ASC/DTC

- The rider is always responsible for adapting his/her driving style.
- Do not reduce the system's extra safety margin with careless riding or unnecessary risks.

#### Special situations

As lean angles increase, acceleration capability is also progressively restricted by the laws of physics. This can result in delayed acceleration when exiting very tight curves

The system compares the rotational speeds of the front and rear wheels to detect any tendency for the rear wheel to spin or lose traction. If the system registers implausible data for an extended period of time, it will deactivate the ASC/DTC functionality as a safety precaution and an ASC/DTC error will be displayed. A self-diagnosis must be completed before the fault memory entry will be displayed.

For the following unusual riding statuses, this can lead to a

BMW Motorrad ASC/DTC error message:

**Unusual riding conditions:**

- Riding on the rear wheel (performing Wheelies) for an extended period with the ASC/DTC deactivated.
- Rear wheel spinning in place with front wheel brake engaged (Burn Out).
- Heating up on auxiliary stand in neutral or with gear engaged.

By switching the ignition off, then on again, and subsequently riding at a minimum speed, the ASC/DTC is activated again.

	Minimum speed for ASC/DTC activation
min 3 mph (min 5 km/h)	

-without riding modes Pro<sup>OE</sup>  
On a slippery surface, the throttle grip should never be suddenly throttled back completely unless the clutch is disengaged at the same time. The engine's braking torque could cause the rear wheel to block, resulting in unstable motorcycle conditions. BMW Motorrad ASC is unable to intervene effectively under these conditions.

## RIDING MODE

### Selection

In order to adjust the motorcycle to the road condition and the desired riding experience, it is possible to select one of the following riding modes:

- RAIN
- ROAD
- with riding modes Pro<sup>OE</sup>
- DYNA

For each of these riding modes, there is a coordinated setting for the ABS and ASC/DTC systems as well as for the throttle response.

ASC/DTC can be switched off in any riding mode. The following explanations always refer to the riding safety systems that are switched on.

### Throttle response

- In riding mode RAIN: Reserved
- In riding mode ROAD: Optimal
- with riding modes Pro<sup>OE</sup>
- In riding mode DYNA: Direct

## 104 TECHNOLOGY IN DETAIL

### ABS

- Rear wheel lift-off detection is active in all riding modes.
- ABS Pro is available in all riding modes to the full extent. The stand-up tendency the motorcycle has when braking while traveling around curves is reduced to a minimum.
- In the RAIN and ROAD riding modes, the ABS is set for road use.
- with riding modes Pro<sup>OE</sup>
- In the DYNA riding mode, the ABS is set for road use.

### ASC

- ASC is attuned for road use.
- In the ROAD riding mode, ASC provides high riding stability, and in the RAIN riding mode it provides maximum riding stability.
- with riding modes Pro<sup>OE</sup>

### DTC

#### Tires

- In the DTC settings RAIN, ROAD, and DYNA, the DTC is set for road use with road tires.

#### Riding stability

- In the DTC setting RAIN, the DTC intervenes early enough to ensure that maximum riding stability is achieved.

- In the DTC setting ROAD, the DTC intervenes later than in RAIN riding mode. Spinning of the rear wheel without traction is avoided wherever possible.
- In the DTC settings RAIN and ROAD, the front wheel is prevented from lifting off.
- In the DTC setting DYNA, the DTC intervenes later than in the DTC setting ROAD, which enables minor drifts at the end of curves and brief wheelies.

#### Switchover

Riding modes can be changed when the vehicle is at a stand-still with the ignition switched on. A changeover while riding is possible under the following conditions:

- No drive torque at rear wheel.
- No brake pressure in the braking system.

For a changeover while riding, the following steps must be carried out:

- Turn back throttle grip.
- Do not actuate brake lever.

- with speed control<sup>OE</sup>
- Deactivate the adaptive cruise control.

First, the desired riding mode is preselected. The switchover does not take place until the affected systems are in the required state.

The selection menu does not disappear from the display until the riding mode has been switched over.

---

## **DYNAMIC ENGINE BRAKE CONTROL**

- with riding modes Pro<sup>OE</sup>

### **How does dynamic engine brake control work?**

The purpose of the dynamic engine brake control is to safely prevent unstable riding conditions that are related to excess drag torque at the rear wheel. Depending on the road condition and driving dynamics, excess drag torque can make the slip at the rear wheel increase severely and impede driving stability. The dynamic engine brake control reduces slip at the rear wheel to a safe, setpoint slip that is dependent on the mode.

### **Causes of excess slip at the rear wheel:**

- Riding in coasting overrun on a road with low coefficient of friction (e.g. wet leaves).
- Hopping when shifting gears down.
- Hard brake onset in sporty riding style.

Like the BMW Motorrad ASC, the dynamic engine brake control compares the wheel circumferential velocities of the front and rear wheel. The dynamic engine brake control can determine the slip, and therefore the stability reserve, on the rear wheel using the speed difference.

If the slip exceeds the respective limit value, the engine torque is increased by slightly opening the throttle valves. The slip is reduced, and the vehicle is stabilized.

### **Effect of the dynamic engine brake control**

- In the RAIN and ROAD riding modes: Maximum stability
- In the DYNA riding mode: Reduced intervention when compared to the RAIN and ROAD riding modes

---

## ADAPTIVE HEADLIGHTS

–with Adaptive Lights<sup>OE</sup>

### Function

In addition to the low beams, high beams and daytime running lights or parking lights, the headlight is equipped with separate LED elements with their own reflectors. Depending on the angle, the LED elements are also switched on for the low beams in order to improve the illumination of the interior range of the curve. The adaptive front lighting is optimized for an angle of up to 25°.

The adaptive front lighting is activated under the following conditions:

- The angle is greater than 7°.
- The speed is higher than 10 km/h.
- The low beams are switched on.





**MAINTENANCE**

**08**

---

<b>GENERAL NOTES</b>	<b>110</b>
<b>ONBOARD VEHICLE TOOL KIT</b>	<b>111</b>
<b>FRONT-WHEEL STAND</b>	<b>111</b>
<b>REAR-WHEEL STAND</b>	<b>112</b>
<b>ENGINE OIL</b>	<b>112</b>
<b>BRAKE SYSTEM</b>	<b>114</b>
<b>CLUTCH</b>	<b>118</b>
<b>TIRES</b>	<b>118</b>
<b>RIMS</b>	<b>120</b>
<b>WHEELS</b>	<b>120</b>
<b>LIGHT SOURCE</b>	<b>129</b>
<b>JUMP-STARTING</b>	<b>130</b>
<b>BATTERY</b>	<b>131</b>
<b>FUSES</b>	<b>133</b>
<b>DIAGNOSTIC SOCKET</b>	<b>135</b>

---

## GENERAL NOTES

The 'Maintenance' chapter describes work involving the checking and replacement of wear parts that can be performed with a minimum of effort.

### Microencapsulated screws

The microencapsulation is a chemical threadlocker. An adhesive is used to create a solid connection between screw and nut or component. Microencapsulated screws, therefore, are suitable for single use only.

After removal, the internal thread must be cleaned to remove adhesive. During installation, a new microencapsulated screw must be used. Therefore, before removal, ensure that you have suitable tools for cleaning the thread and have a replacement screw. If you carry out the work improperly, the locking function of the screw might no longer be guaranteed, which puts you in danger!

### Additional information

If special tightening torques are to be taken into account for installation, these are listed. An overview of all required tightening torques is contained in the chapter "Technical data". Information on additional preventive maintenance and repair procedures is provided in the repair manual for your motorcycle on DVD, which you can obtain from your authorized BMW Motorrad retailer.

Special tools and thorough specialized knowledge are required to carry out some of the work described here. If you are in doubt, consult a specialist workshop, preferably your authorized BMW Motorrad retailer.

## ONBOARD VEHICLE TOOL KIT

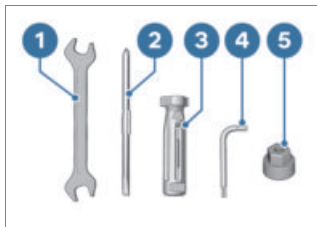

- 1 Open-ended wrench AF 14/17
  - Adjusting mirror arm (▮▮▮ 64).
  - Adjusting the spring preload on the front wheel (▮▮▮ 68).
- 2 Reversible screwdriver insert with Phillips and slotted blade
  - Adjusting the rebound-stage damping on front wheel (▮▮▮ 71).
  - Adjusting the compression damping on the front wheel (▮▮▮ 70).
  - Adjusting damping at the rear wheel (▮▮▮ 71).
- 3 Screwdriver handle
  - Topping up the engine oil (▮▮▮ 113).
  - Use with screwdriver insert
- 4 Torx wrench T20
- 5 Plastic top part
  - Adjusting the spring preload on the front wheel (▮▮▮ 68).

## FRONT-WHEEL STAND

### Attaching front-wheel stand



#### ATTENTION

#### Use of the BMW Motorrad front wheel stand without an auxiliary stand

Component damage cause by tipping over

- Place the motorcycle on an auxiliary stand before lifting the front wheel with the BMW Motorrad front-wheel stand.
- Ensure that the motorcycle is standing securely.
- Place motorcycle on an auxiliary stand; BMW Motorrad recommends the BMW Motorrad auxiliary stand.
- Mounting the rear-wheel stand (▮▮▮ 112).

# 112 MAINTENANCE



- For a description of the correct installation, please refer to the instructions for the front-wheel stand.
- BMW Motorrad offers a suitable auxiliary stand for each motorcycle. Your authorized BMW Motorrad retailer will be very happy to assist you in choosing the suitable auxiliary stand.

## REAR-WHEEL STAND

### Mounting the rear-wheel stand



- For a description of the correct installation, please re-

fer to the instructions for the rear-wheel stand.

- BMW Motorrad offers a suitable auxiliary stand for each motorcycle. Your authorized BMW Motorrad retailer will be very happy to assist you in choosing the suitable auxiliary stand.

## ENGINE OIL

### Checking engine oil level



#### ATTENTION

**Misinterpretation of the oil filling quantity, as the oil level is temperature-dependent (the higher the temperature, the higher the oil level)**

Engine damage

- Only check the oil level after a longer journey or when the engine is warm.
  - Switch off engine at operating temperature.
  - Hold the motorcycle vertically, making sure that the ground is firm and level.
  - Wait five minutes to allow oil to drain into the oil pan.
-  BMW Motorrad recommends occasionally checking the motor oil after a journey of at least 31 mi in order

to reduce the environmental impact.

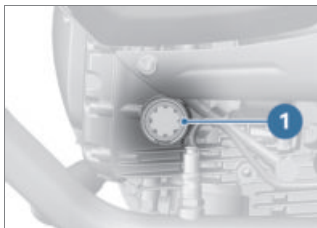

### ATTENTION

**Lateral tipping of the vehicle**  
Component damage cause by tipping over

- Secure the vehicle from tipping over laterally, preferably with the support of a second person.

- Read oil level on the display **1**.

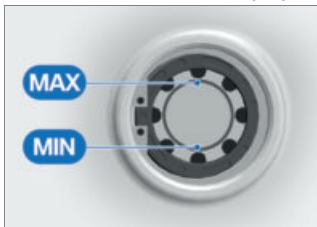

Specified level of engine oil

Between **MIN** and **MAX** mark

If the oil level is below the minimum mark:

- Topping up the engine oil (➔ 113).

If the oil level is above the maximum mark:

- Have oil level corrected at a specialist workshop, preferably an authorized BMW Motorrad retailer.

### Topping up the engine oil

- Park the motorcycle, making sure that the ground is firm and level.

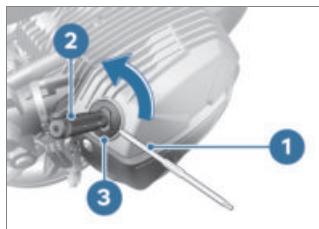

- Clean the area around the oil filler opening.
- To be able to apply force more easily, insert the interchangeable screwdriver bit **1** Phillips-end first, into the screwdriver handle **2** (on-board vehicle tool kit).
- Place the onboard vehicle tool kit on the oil filler plug **3** and turn counterclockwise.
- Remove the oil filler plug **3**.

# 114 MAINTENANCE

## ATTENTION

### Use of too little or too much engine oil

Engine damage

- Always make sure that the oil level is correct.
- Top up the engine oil to the specified level.



Engine oil, quantity for topping up

max 0.5 quarts (max 0.5 l)  
(Difference between MIN and MAX)

- Checking engine oil level (→ 112).
- Install the oil filler plug **3**.

## BRAKE SYSTEM

### Check brake operation

- Actuate the handbrake lever.
  - » Pressure point must be clearly perceptible.
- Actuate the footbrake lever.
  - » Pressure point must be clearly perceptible.

If no clear pressure points are perceptible:

## ATTENTION

### Improper working on the brake system

Endangering of the operating safety of the brake system

- Have all work on the brake system carried out by experts.
  - Have the brakes checked at an authorized workshop, preferably an authorized BMW Motorrad retailer.
- ### Checking the front brake pad thickness
- Park the motorcycle, making sure that the ground is firm and level.

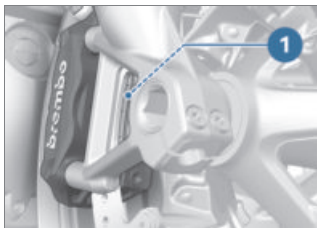

- Visually inspect the brake pad thickness on the left and right. Viewing direction: Between wheel and front suspension toward brake pads **1**.



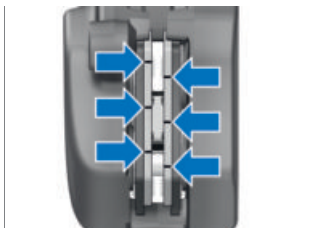

 Front brake-pad wear limit

0.04 in (1.0 mm) (Only friction material without carrier plate. The wear marks (grooves) must be clearly visible.)

If the wear marks are no longer clearly visible:

### **WARNING**

#### **Dropping below the minimum pad thickness**

Reduced braking action, damage to the brake

- In order to ensure the operating reliability of the brake system, make sure that the brake pads are not worn beyond their minimum thickness.

- Have brake pads replaced at a specialist workshop, preferably an authorized BMW Motorrad retailer.

### **Checking the rear brake pad thickness**

- Park the motorcycle, making sure that the ground is firm and level.



- Conduct a visual inspection of the brake pad thickness. Direction of view: From left onto brake caliper.



 Rear brake-pad wear limit

0.04 in (1.0 mm) (Only friction material without carrier plate. Brake pad must not be visible through bore hole of inner brake pad.)

## 116 MAINTENANCE

If the brake disc is visible:



### WARNING

#### Dropping below the minimum pad thickness

Reduced braking action, damage to the brake

- In order to ensure the operating reliability of the brake system, make sure that the brake pads are not worn beyond their minimum thickness.
- Have brake pads replaced at a specialist workshop, preferably an authorized BMW Motorrad retailer.

#### Brake pad wear

The rear wheel brake has a brake-pad wear indicator.

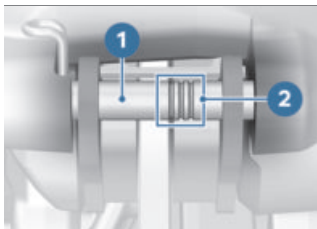

The axle **1** with the three ring marks **2** is located between the brake pads.

#### How to interpret the marks:

- 3 rings visible: at least 75% brake pad thickness
- 2 rings visible: at least 50% brake pad thickness
- 1 ring visible: at least 25% brake pad thickness
- No ring visible: wear limit has been reached, check as described earlier

#### Checking the front brake fluid level



### WARNING

#### Insufficient or contaminated brake fluid in the brake fluid reservoir

Considerably reduced braking power caused by air, dirt or water in the brake system

- Stop riding immediately until fault is rectified.
- Check brake fluid level regularly.
- Make sure that the lid of the brake fluid reservoir is cleaned before opening.
- Make sure that brake fluid is used from a sealed container only.
- Park the motorcycle, making sure that the ground is firm and level.



- Align the handlebars so that the brake fluid reservoir is positioned horizontally.
- Check the brake fluid level in the sight glass **1**.

 The brake fluid level in the brake-fluid reservoir drops due to brake pad wear.



Front brake fluid level

Brake fluid, DOT4

The brake fluid level must not fall below the MIN mark. (Brake fluid reservoir horizontal, motorcycle standing upright.)

If the brake fluid level falls below the approved level:

- Have the defect rectified as quickly as possible by a specialist workshop, preferably an authorized BMW Motorrad retailer.

### Checking the rear brake fluid level

#### **WARNING**

#### **Insufficient or contaminated brake fluid in the brake fluid reservoir**

Considerably reduced braking power caused by air, dirt or water in the brake system

- Stop riding immediately until fault is rectified.
- Check brake fluid level regularly.
- Make sure that the lid of the brake fluid reservoir is cleaned before opening.
- Make sure that brake fluid is used from a sealed container only.

- Park the motorcycle, making sure that the ground is firm and level. Hold vehicle straight.

# 118 MAINTENANCE



- Check brake fluid level at brake fluid reservoir for rear wheel brake **1**.

 The brake fluid level in the brake-fluid reservoir drops due to brake pad wear.



Rear brake fluid level

Brake fluid, DOT4

The brake fluid level must not fall below the **MIN** mark. (Brake fluid reservoir horizontal)

If the brake fluid level falls below the approved level:

- Have the defect rectified as quickly as possible by a specialist workshop, preferably an authorized BMW Motorrad retailer.

---

## CLUTCH

### Checking clutch function

- Pull back the clutch lever.
  - » Pressure point must be clearly perceptible.

If no clear pressure point can be felt:

- Have the clutch checked by an authorized workshop, preferably an authorized BMW Motorrad retailer.

---

## TIRES

### Checking tire pressure



#### WARNING

#### Incorrect tire inflation pressure

Poorer handling characteristic of motorcycle, reduction of tire service life

- Ensure proper tire inflation pressure.

**WARNING****Automatic opening of vertically installed valve inserts at high speeds**

Sudden loss of tire inflation pressure

- Use valve caps with rubber sealing ring and screw on firmly.
- Park motorcycle, ensuring that support surface is firm and level.
- Check tire pressures against data below.



Front tire pressure

36.3 psi (2.5 bar) (with tire cold)



Rear tire pressure

39.2 psi (2.7 bar) (One-up, with cold tires)

42.1 psi (2.9 bar) (Two-up and cargo, with cold tires)

If tire pressure incorrect:

- Correct tire pressure.

**Check tire tread depth****WARNING****Riding with heavily worn tyres**

Risk of accident due to poorer rideability

- If necessary, replace the tyres before the legally specified minimum tread depth is reached.
  - Park motorcycle, ensuring that support surface is firm and level.
  - Measure tire tread depth in main tread grooves with wear indicators.
-  Tread wear marks are integrated into the main grooves on every tire. If the tire tread has worn down to the level of the marks, the tire is completely worn. The locations of the marks are indicated on the edge of the tire, e.g. by the letters TI, TWI or by an arrow.
- When the minimum tread depth is reached:
- Replace the worn tires.

---

## RIMS

### Checking wheel rims

- Park motorcycle, ensuring that support surface is firm and level.
- Subject wheel rims to visual inspection for defects.
- Have damaged rims checked and, if necessary, replaced by a specialist service facility, preferably an authorized BMW Motorrad retailer.

### Checking spokes

- Park motorcycle, ensuring that support surface is firm and level.
- Using the handle of a screwdriver or similar object, run it over the spokes and listen to the sound pattern.

If the sound pattern is uneven:

- Have spokes checked by a specialist workshop, preferably by an authorized BMW Motorrad Retailer.

---

## WHEELS

### Effect of wheel sizes on suspension control systems

The wheel sizes play an important role with suspension control systems such as ABS. The diameter and width of the wheels stored in the control unit have particular significance as the basis for all necessary

calculations. A change in these sizes resulting from conversion to wheels not installed as standard equipment can seriously affect the control efficiency of these systems.

The sensor rings required for wheel speed detection must also match the installed control systems and may not be replaced.

If you want to convert your motorcycle to different wheels, please contact a specialist workshop, preferably a BMW Motorrad retailer. In some cases the data stored in the control units must be adapted to the new wheel sizes.

### Removing the front wheel

 To simplify wheel removal/installation, the front wheel cover must be released on one side.

- Place the motorcycle on an auxiliary stand. BMW Motorrad recommends you use the BMW Motorrad rear-wheel stand.
- Mounting the rear-wheel stand (112).
- Raise front of motorcycle, preferably using a BMW Motorrad front-wheel

stand, continuing until the front wheel rotates freely.

- Attaching front-wheel stand (→ 111).

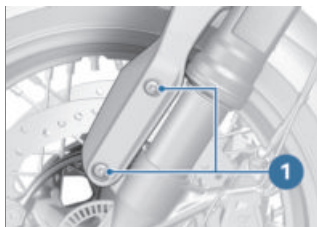

- Slacken screws **1**.



- Detach the sensor cable from the brackets **2**.
- Remove the screw **1** and remove the wheel speed sensor **3** from the drilled hole.

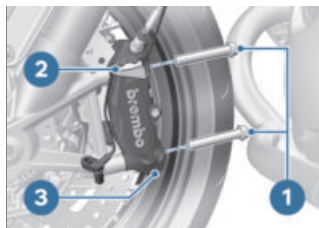

- Remove the screws **1** on the left.
- Loosen the bracket **2** for the sensor cable and brake caliper **3**.

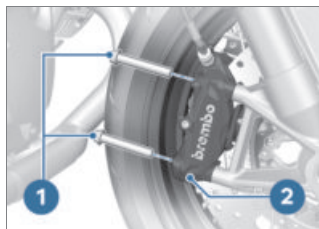

- Remove the screws **1** on the right and loosen the brake caliper **2**.

## 122 MAINTENANCE



- Push the brake pads **1** apart slightly by turning the brake caliper **2** against the brake disc **3**.

### ATTENTION

#### Unintentional pressing together of brake pads

Component damage when mounting the brake caliper or when pressing the brake pads apart

- Do not actuate the brakes with the brake caliper removed.

### ATTENTION

#### Using hard or sharp-edged objects near the component

Component damage

- Do not scratch components, if necessary tape off or cover.
- Carefully pull the brake calipers back and outward to

remove them from the brake discs.

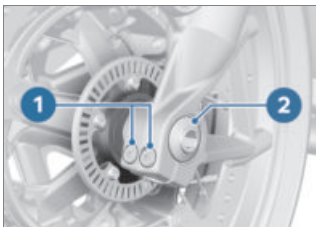

- Loosen screw **2** but **do not remove**.
- Unscrew the clamping bolts **1** on left and right.
- Slightly press the quick-release axle inward for a better grip on the right side.
- Remove the screw **2**.



- Pull out the quick-release axle **3** while supporting the front wheel.
- Place front wheel down and roll it forward out of the front suspension.





- Remove spacer bushing **4** from front wheel hub.

### Installing the front wheel

#### **WARNING**

#### **Use of a wheel which does not comply with series specifications**

Malfunctions during control interventions by ABS and ASC/DTC

- Please see the information on the effect of wheel sizes on the ABS and ASC/DTC chassis control systems at the beginning of this chapter.

#### **ATTENTION**

#### **Tightening of screwed connections with incorrect tightening torque**

Damage or loosening of screwed connections

- Always have the tightening torques checked by a specialized workshop, preferably an authorized BMW Motorrad retailer.



- Lubricate the contact surface on the spacer bushing **4**.



Lubricant

Optimoly TA

- Insert the spacer bushing **4** into the wheel hub on the left side with the seat facing outwards.

## 124 MAINTENANCE

### ATTENTION

#### Front wheel installation opposite the running direction

Accident hazard

- Observe running direction arrows on tire or rim.
- Roll the front wheel into the front suspension.



- Lubricate the quick-release axle **3**.



Lubricant

Optimoly TA

### WARNING

#### Improper installation of quick-release axle

Loosening of the front wheel

- After the brake caliper is fastened and the spring fork is relaxed, tighten the quick-release axle and axle clamping with the specified torque.
- Lift the front wheel and install the quick-release axle **3**.
- Remove front wheel stand and firmly compress front forks. Do not actuate hand-brake lever at the same time.
- Attaching front-wheel stand ( 111).



- Install screw **2**. Brace quick-release axle on the right side at the same time.



Screw on quick-release axle

37 lb/ft (50 Nm)

- Tighten the clamping bolts **1** on left and right to the appropriate torque.



 Clamping bolts in axle mount

Tightening sequence: Tighten the screws 6 times, alternating between one and the other each time

14 lb/ft (19 Nm)

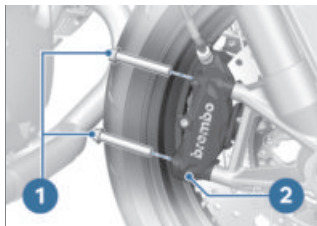

- Position brake caliper **2** on right and install screws **1**.

 Brake caliper on telescopic forks

28 lb/ft (38 Nm)

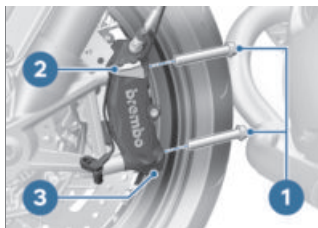

- Position left brake caliper **3** and bracket for sensor cable **2**.
- Install screws **1**.

 Brake caliper on telescopic forks

28 lb/ft (38 Nm)

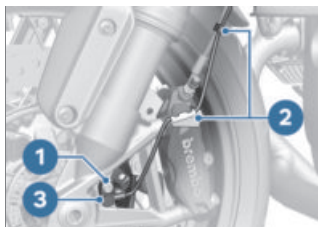

- Insert the wheel speed sensor **3** into the drilled hole and install screw **1**.

 Wheel speed sensor on fork

6 lb/ft (8 Nm)

- Insert the sensor cable into the brackets **2**.

## 126 MAINTENANCE



### WARNING

#### Brake pads do not contact the brake disc

Risk of accident due to delayed braking effect.

- Before driving off, check that the braking effect kicks in without any delay.
- Engage the brakes repeatedly, continuing until the brake pads make contact with the discs.

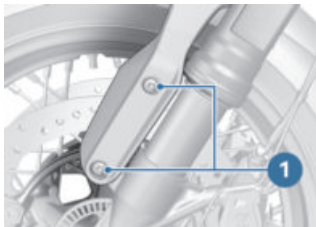

- Tighten screws **1**.



Front wheel cover on fork

4 lb/ft (5 Nm)

- Remove the front-wheel stand.
- Fold out the side stand.
- Remove the rear-wheel stand.
- Place motorcycle on its side stand.

### Removing the rear wheel

- Raise motorcycle, preferably with a BMW Motorrad rear-wheel stand.
- Engage first gear.
- Mounting the rear-wheel stand (➡ 112).

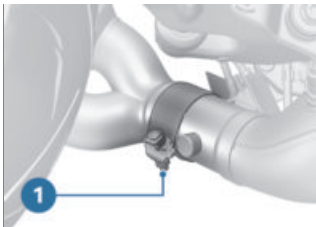

### CAUTION

#### Hot exhaust system

Burn hazard

- Do not touch hot exhaust system.
- Loosen screw **1** of the clip and slide the clip toward rear.
- Do not remove sealing grease from clip.

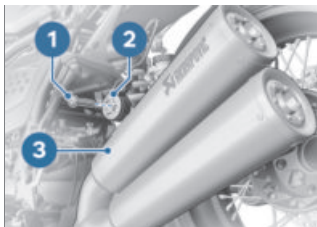

- Remove screw **1** and lock washer **2** of the silencer bracket from the passenger footrest.
- Pull off the silencer **3** toward rear and place it on a soft surface.

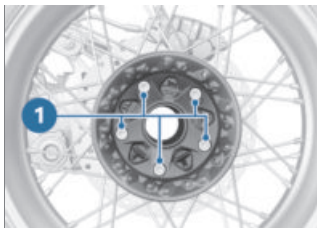

- Remove screws **1** while supporting wheel.
- Roll rear wheel out toward rear.

## Installing the rear wheel

### **WARNING**

#### **Use of a wheel which does not comply with series specifications**

Malfunctions during control interventions by ABS and ASC/DTC

- Please see the information on the effect of wheel sizes on the ABS and ASC/DTC chassis control systems at the beginning of this chapter.

### **ATTENTION**

#### **Tightening of screwed connections with incorrect tightening torque**

Damage or loosening of screwed connections

- Always have the tightening torques checked by a specialized workshop, preferably an authorized BMW Motorrad retailer.
- Clean wheel centering device and contact surfaces of wheel hub.

# 128 MAINTENANCE

## ATTENTION

Using hard or sharp-edged objects near the component  
Component damage

- Do not scratch components, if necessary tape off or cover.

- Place rear wheel on rear wheel support.

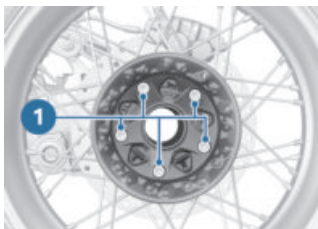

- Install screws **1**.

 Rear wheel on wheel carrier

Tightening sequence: Tighten crosswise

44 lb/ft (60 Nm)

- Attach the silencer to the pipe on the exhaust flap.

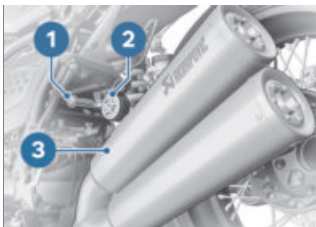

- Align silencer **3**, fit lock washer **2** and install screw **1**, but do not tighten yet.

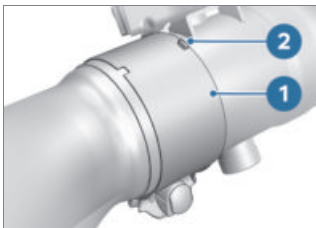

- Align the circlip with recess **1** to the snap-in lug **2**.  
» Snap-in lug engages in the recess of the circlip.

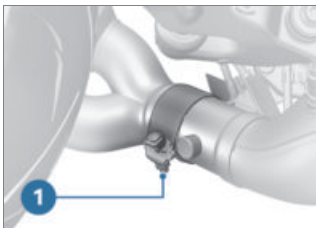

- Tighten screw **1**.

 Clamp on silencer and exhaust manifold

21 lb/ft (28 Nm)



- Tighten screw **1**.

 Silencer on passenger frame

14 lb/ft (19 Nm)

- Fold out the side stand.
- Remove the rear-wheel stand.
- Place motorcycle on its side stand.

## LIGHT SOURCE

### Replacing the LED light source

#### WARNING

**Overlooking the vehicle in traffic due to a defective light source on the vehicle**  
Safety risk

- Replace defective light sources as quickly as possible. For details please contact a specialist service facility, preferably an authorized BMW Motorrad Retailer.

All light sources on the vehicle are LED light sources. The service life of the LED light sources is longer than the assumed service life of the vehicle. If an LED light source is faulty, please contact a specialist workshop, preferably an authorized BMW Motorrad retailer.

# 130 MAINTENANCE

## JUMP-STARTING

### CAUTION

**Touching live parts of the ignition system when the engine is running**

Electrocution

- Do not touch parts of the ignition system when the engine is running.

### ATTENTION

**Current too high when jump-starting the motorcycle**

Cable fire or damage to the motorcycle electronics

- Do not jump-start the motorcycle using the power socket, only via the battery terminal.

### ATTENTION

**Contact between crocodile clips of jump leads and motorcycle**

Danger of short circuit



- Use jump leads fitted with fully insulated crocodile clips at both ends.

### ATTENTION

**Jump-starting with a voltage higher than 12 V**

Damage to the motorcycle's electronics

- The battery of the donor motorcycle must have a voltage of 12 V.
- Park the motorcycle, making sure that the ground is firm and level.

- Removing passenger seat ( 61).
- Removing the rider's seat ( 61).

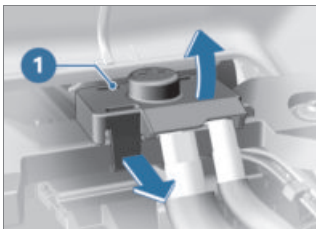

- Unclip cover panel **1** at bottom (**arrow**) and lift off.



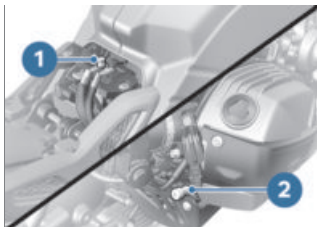

- Begin by connecting one end of the red jumper cable to the jump-start terminal **1** on the discharged battery and the other end to the positive terminal of the donor battery.
- Use the black jumper cable to connect the ground jump-start terminal **2** on your vehicle to the negative terminal of the second battery.
- Run engine of donor motorcycle during jump-starting procedure.
- Start the engine of the vehicle with discharged battery as usual, wait a few minutes before repeating the attempt to protect the starter motor and the donor battery.

 To start the engine, do not use start sprays or similar items.

- Allow both engines to idle for a few minutes before disconnecting jumper cables.

- First, disconnect the jumper cable from the ground jump-start terminal **2** and then from the jump-start terminal **1**.

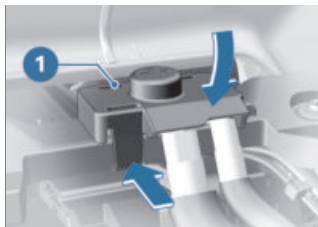

- Install cover **1**.
- Installing rider's seat (▣▣▣ 61).
- Installing the passenger seat (▣▣▣ 61).

## BATTERY

### Maintenance instructions

Correct battery maintenance combined with proper charging and storage procedures extends the battery's service life, and is also required for warranty claims.

Compliance with the points below is important in order to maximize battery life:

- Keep the surface of the battery clean and dry.
- Do not open the battery.
- Do not top up with water.
- Be sure to read and comply with the instructions for

## 132 MAINTENANCE

charging the battery on the following pages.

- Do not turn the battery upside down.



### ATTENTION

#### **Discharging of the connected battery by the vehicle electronics (e.g. clock)**

Total discharge of battery leading to a rejection of warranty claims

- During riding breaks of more than 4 weeks, connect a trickle-charger to the battery.



BMW Motorrad has developed a trickle-charger specially designed for compatibility with the electronics of your motorcycle. Using this charger, you can keep the battery charged during long periods when the motorcycle is not being used without having to disconnect the battery from the motorcycle's onboard systems. Additional information is available at your authorized BMW Motorrad retailer.

### Charging a connected battery



### ATTENTION

#### **Unsuitable chargers connected to the power socket**

Damage to charger and vehicle electronics

- Use suitable BMW chargers. The correct charger is available through your authorized BMW Motorrad retailer.

- Remove devices connected to the power socket.
- Comply with operating instructions of charger.
- Charge battery connected to the vehicle via power socket.



The motorcycle's onboard electronics know when the battery is fully charged. The onboard socket is switched off when this happens.



If you are unable to charge the battery via the onboard socket, you may be using a charger that is not compatible with your motorcycle's electronics. In this case, charge the battery directly from the terminals of the battery disconnected from the vehicle.

**ATTENTION**

**A fully discharged battery must be charged via a power socket or extra socket.**

Damage to vehicle electronics

- A fully discharged battery (battery voltage less than 12 V, indicator lights and multifunction display remain off when ignition is switched on) must always be charged directly at the poles of the **disconnected** battery.

**ATTENTION**

**Charging the battery connected to the vehicle using the battery terminals**

Damage to the motorcycle's electronics

- Disconnect the battery before charging on the battery terminals.

- Charge battery at the terminals directly.

**Charging a disconnected battery**

- Charge battery using a suitable charger.
- Comply with operating instructions of charger.

- Once battery is fully charged, disconnect charger's terminal clips from battery terminals.



In the case of longer periods when the motorcycle is not being used, the battery must be recharged regularly. See the instructions for caring for your battery. Always fully recharge the battery before returning it to use.

**Replacing the battery**

In the event that the battery is faulty, contact a specialist workshop, preferably an authorized BMW Motorrad retailer.

**FUSES****Replacing fuses****ATTENTION****Bypassing defective fuses**

Risk of short circuit and fire

- Do not bypass defective fuses.
- Replace defective fuses with new fuses.
- Switch off the ignition.
- Park the motorcycle, making sure that the ground is firm and level.
- Removing passenger seat (▶▶▶ 61).

# 134 MAINTENANCE

- Removing the rider's seat (▮▮▮▮▶ 61).

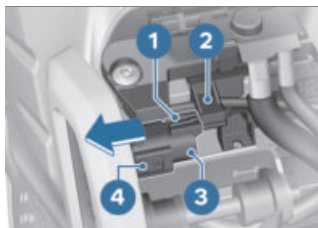

- Press hook **1**.  
» The fuse box is unlocked and can be pulled to the left and detached from holder **2**.
- Pull the fuse box out of holder **2**.
- Press lock **4** on both sides and remove cap **3**.

 If the fuses blow frequently, have the electrical system checked by an authorized specialized workshop, preferably an authorized BMW Motorrad retailer.

- Replace defective fuse in accordance with following fuse assignment diagram.  
» Fuse assignment (▮▮▮▮▶ 134)
- Install cap **3** again. Make sure that the lock **4** engages.
- Slide the fuse box into holder **2** until hook **1** engages.
- Installing rider's seat (▮▮▮▮▶ 61).

- Installing the passenger seat (▮▮▮▮▶ 61).

## Fuse assignment

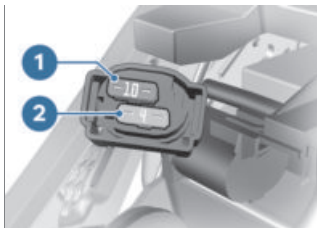

 Fuse 1

10 A (Instrument cluster, anti-theft alarm system DWA, ignition switch, OBD diagnostic socket, coil for cut-off relay)

 Fuse 2

4 A (Sensor box, multifunction switch on left)

## DIAGNOSTIC SOCKET

### Loosening the diagnostic socket



#### CAUTION

**Incorrect procedure followed when disconnecting the data link connector for the On-Board Diagnostics.**

Motorcycle experiences malfunctions

- Only have the data link connector disconnected by a specialist workshop or other authorized persons during your next BMW Service appointment.
  - Have the work performed by appropriately trained staff.
  - Refer to the vehicle manufacturer specifications.
- Removing passenger seat (▮▮▮▮ 61).
  - Removing the rider's seat (▮▮▮▮ 61).



- Press locking mechanisms **1**.
  - Loosen the diagnostic socket **2** from the bracket **3**.
- » The interface for the diagnosis and information system can be connected to the diagnostic socket **2**.

### Fastening the diagnostic socket

- Disconnect the interface for the diagnosis and information system.

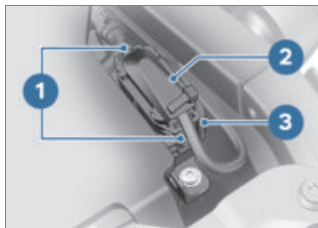

- Insert the diagnostic socket **2** into the bracket **3**.
- » The locks **1** engage.
- Installing rider's seat (▮▮▮▮ 61).
  - Installing the passenger seat (▮▮▮▮ 61).

# ACCESSORIES

09

---

<b>GENERAL NOTES</b>	<b>138</b>
<b>USB CHARGING SOCKET</b>	<b>138</b>
<b>LUGGAGE</b>	<b>139</b>
<b>PASSENGER FRAME</b>	<b>140</b>
<b>HUMP COVER</b>	<b>145</b>
<b>OPTIONAL ACCESSORIES</b>	<b>147</b>

## GENERAL NOTES



### CAUTION

#### Use of products from other manufacturers

##### Safety risk

- BMW Motorrad cannot examine or test each product of outside origin to ensure that it can be used on or in connection with BMW motorcycles without constituting a safety hazard. Nor is this guarantee provided when the official approval of a specific country has been granted. Tests conducted by these instances cannot make provision for all operating conditions experienced by BMW motorcycles and, consequently, they are not sufficient in some circumstances.
- Use only parts and accessories approved by BMW for your motorcycle.

The safety, operation and suitability of the parts and accessory products have been thoroughly tested by BMW. Therefore, BMW assumes responsibility for these products. BMW shall not be held liable for un-

approved parts and accessory products of any kind.

Comply with legal requirements for any modifications.

The motorcycle shall not violate the regulations governing motorcycle approval for highway use applicable in your own country.

Your BMW Motorrad retailer offers you expert advice when choosing genuine BMW parts, accessories and other products. More information on the topic of accessories is available at: [bmw-motorrad.com/equipment](http://bmw-motorrad.com/equipment)

## USB CHARGING SOCKET

Notes about use:

### Charge current

This is a 5 V USB charging socket providing a maximum charge current of 2.4 A.

### Automatic shut-off

The USB charging sockets are automatically switched off under the following conditions:

- To retain the starting capability if the battery voltage is too low.
- If the maximum load capacity specified in the technical data is exceeded.
- During the starting procedure.



## Connection of electrical devices

The ignition must be switched on before electrical devices connected to USB charging sockets can be operated. To reduce loads on the electrical system, these are switched off no more than 15 minutes after the ignition has been switched off.

To protect the connected device, the device should be unplugged when riding in rain. When no device is connected, the cover should be closed to prevent soiling.

## Cable routing

Observe the following when routing cables from USB charging sockets to additional devices:

- Cables must not impede the rider.
- Cables must not restrict the steering angle and handling characteristics.
- Cables must not become trapped.

## LUGGAGE

### Securing luggage on the motorcycle



#### WARNING

#### Reduced riding stability caused by overloading and uneven loading

Accident hazard

- Do not exceed the gross weight limit and observe the loading information.



- Secure luggage (for example, rear bag) on lashing eyes **1**.
- Observe maximum payload.



Payload of rear bag

–with rear bag<sup>OA</sup>

max 22 lbs (max 10 kg) <

» Additional information on the luggage systems and their attachment is available from your authorized BMW Motorrad retailer.

## PASSENGER FRAME

### Removing passenger frame



#### ATTENTION

#### Hard or sharp-edged components

Scratching or damage to the paint

- Use pads or tape off the areas at risk of scratching or damage.



The installation of an additional OA (silencer bracket) is essential for removing the passenger frame. Detailed information can be obtained from your authorized BMW Motorrad retailer or online at [www.bmw-motorrad.com](http://www.bmw-motorrad.com).

Please observe the general information at the beginning of this chapter.

- Park motorcycle, ensuring that support surface is firm and level.
- Mounting the rear-wheel stand (▮▮▮▮ 112).
- Removing passenger seat (▮▮▮▮ 61).
- Removing the rider's seat (▮▮▮▮ 61).

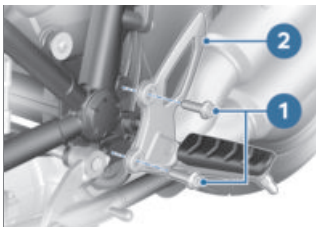

- Remove screws **1** and take off left footrest system **2**.

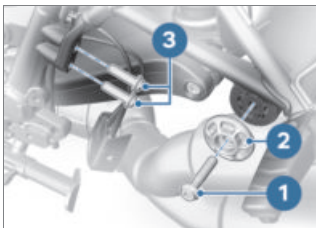

- Remove screw **1** and washer **2**.
- Remove screws **3**.

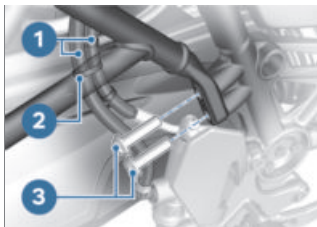
**ATTENTION****Pinching of components**

Component damage

- Do not pinch components, e.g. brake lines or wiring harnesses.

- Detach cable ties **2** from the wires **1**.
- Remove screws **3**.

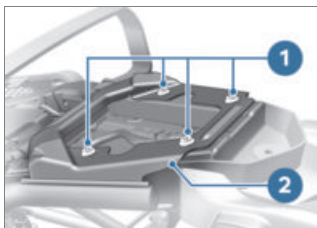

- Remove screws **1** and take off passenger frame **2** backwards.

–with carrier for silencer<sup>OA</sup>

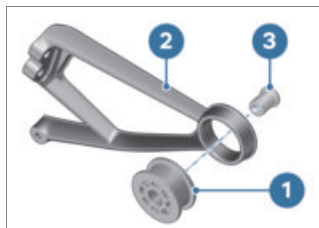

- Remove the rubber decoupler **1** and shouldered bushing **3** from the removed passenger frame.
- Secure rubber decoupler **1** in bracket **2** for silencer and install shouldered bushing **3** from the right.

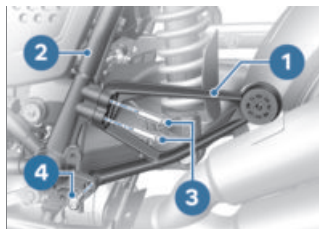

- Position bracket **1** for silencer on rear frame **2**.
- Tighten screws **3** and **4**.

Bracket for silencer on rear frame

–with carrier for silencer<sup>OA</sup>

14 lb/ft (19 Nm)◁

## 142 ACCESSORIES

—with carrier for silencer<sup>OA</sup>

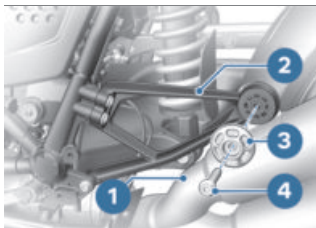

- Align silencer **1** on bracket **2**, position lock washer **3** and install screw **4**.



Silencer on bracket

7 lb/ft (10 Nm) <

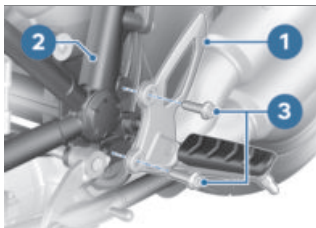

- Position footrest system **1** at rear frame **2** on left and install screws **3**.



Footrest system on rear frame

14 lb/ft (19 Nm)

### Loading correctly without passenger frame

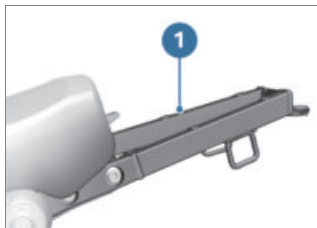

#### WARNING

**Reduced riding stability caused by overloading and uneven loading**

Accident hazard

- Do not exceed the gross weight limit and observe the loading information.

- After the passenger frame is removed, the maximum load in the area of the luggage rack **1** (see figure) must be complied with.



Load capacity of the luggage frame

max 18 lbs (max 8 kg)

## Installing passenger frame



### ATTENTION

#### Hard or sharp-edged components

Scratching or damage to the paint

- Use pads or tape off the areas at risk of scratching or damage.

- Parking your motorcycle (▮▮▮ 140).
- Mounting the rear-wheel stand (▮▮▮ 112).
- Removing the rider's seat (▮▮▮ 61).

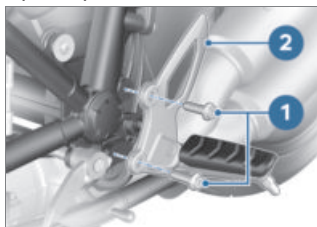

- Remove screws **1** and take off left footrest system **2**.

–with carrier for silencer<sup>OA</sup>

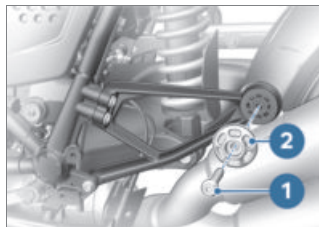

- Remove screw **1** and washer **2**.

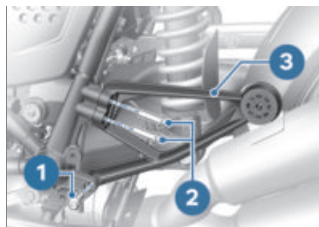

- Remove the screws **1** and **2**.
- Take off bracket **3** for silencer.◁

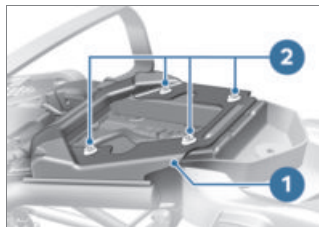

- Insert passenger frame **1** from rear and install screws **2** loosely.

## 144 ACCESSORIES

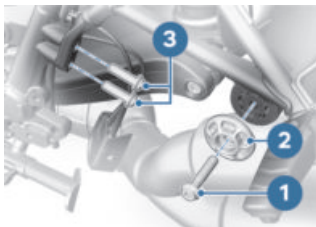

- Install screw **1** and lock washer **2** loosely.
- Install screws **3**.

 Passenger seat frame on rear frame

14 lb/ft (19 Nm)

- Tighten screw **1**.

 Silencer on passenger frame

14 lb/ft (19 Nm)

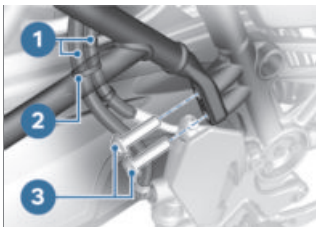

### ATTENTION

#### Pinching of components

Component damage

- Do not pinch components, e.g. brake lines or wiring harnesses.

- Secure wires **1** using a cable tie **2**.
- Install screws **3**.

 Passenger seat frame on rear frame

14 lb/ft (19 Nm)

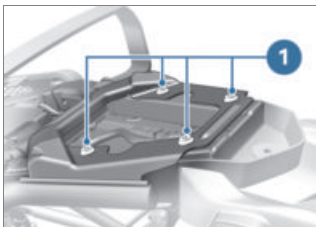

- Tighten screws **1**.

 Passenger seat from on luggage frame

6 lb/ft (8 Nm)

- Remove adhesive tape.

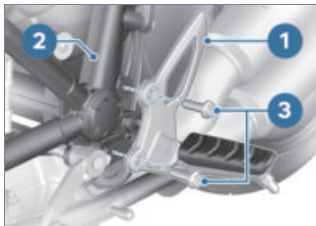

- Position footrest system **1** at rear frame **2** on left and install screws **3**.

 Footrest system on rear frame

14 lb/ft (19 Nm)

- Installing rider's seat (▶▶▶ 61).
- Installing the passenger seat (▶▶▶ 61).
- Remove rear-wheel stand.

## HUMP COVER

—with hump cover<sup>OA</sup>

### Installing the hump cover

- Removing passenger seat (▶▶▶ 61).
- Removing the rider's seat (▶▶▶ 61).

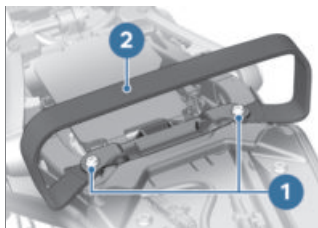

- Remove the screws **1** and save them for reuse.
- Remove the retaining belt **2**.

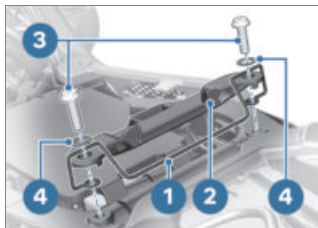

- Insert the retaining bracket **1** below the retaining bridge for the rider's seat **2**.
- Install screws **3** with washers **4**.

 Retaining bridge on rear frame

6 lb/ft (8 Nm)

- Installing rider's seat (▶▶▶ 61).

## 146 ACCESSORIES

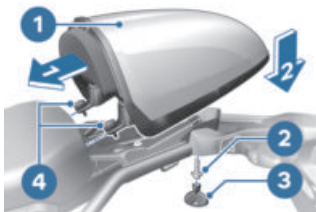

- Insert the hump cover **1** in the retaining bracket, making sure that the stop pads **4** of the hump cover are engaged in the retaining bracket.
- Hand-tighten the screw **2** with the motorcycle seat key **3**.

### Removing the hump cover

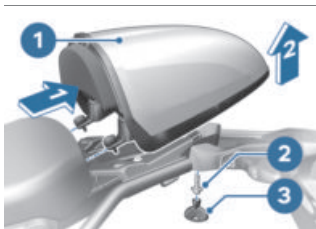

- Remove the screw **2** with the motorcycle seat key **3**.
- Pull the hump cover **1** back and remove it.

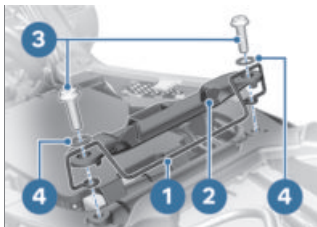

- Remove the screws **3** with washers **4**.
- Remove the retaining bracket **1** below the retaining bridge for the rider's seat **2**.

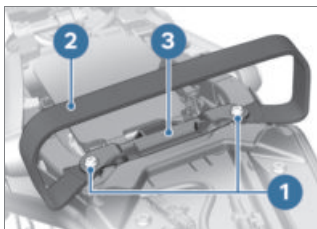

- Insert the retaining belt **2** below the retaining bridge for the rider's seat **3**.
- Install screws **1**.

 Retaining bridge on rear frame

6 lb/ft (8 Nm)

- Installing rider's seat (▣▣▣ 61).
- Installing the passenger seat (▣▣▣ 61).



---

## OPTIONAL ACCESSORIES

### Available optional accessories



Your authorized BMW Motorrad retailer offers you qualified advice in choosing genuine BMW parts, accessories and other products such as aluminum humps or covers for the rear frame. You can find all optional accessories from BMW Motorrad on our website: **[bmw-motorrad.com](http://bmw-motorrad.com)**.

**CARE**

**10**

---

<b>CARE PRODUCTS</b>	<b>150</b>
<b>WASHING YOUR MOTORCYCLE</b>	<b>150</b>
<b>CLEANING SENSITIVE MOTORCYCLE PARTS</b>	<b>151</b>
<b>PAINT CARE</b>	<b>152</b>
<b>PAINT PRESERVATION</b>	<b>153</b>
<b>STORING THE MOTORCYCLE</b>	<b>153</b>
<b>PUTTING THE MOTORCYCLE INTO OPERATION</b>	<b>153</b>

## CARE PRODUCTS

BMW Motorrad recommends that you use cleaning and care products available at your authorized BMW Motorrad retailer. BMW Motorrad Care Products have been materials tested, laboratory tested, and field tested and provide optimum care and protection for the materials used in your vehicle.



### ATTENTION

#### Use of unsuitable cleaning and care agents

Damage to motorcycle parts

- Do not use any solvents such as nitro thinners, cold cleaners, fuel or similar, and do not use cleaning agents that contain alcohol.



### ATTENTION

#### Use of highly acidic or alkaline cleaning agents

Damage to motorcycle parts

- Observe the dilution ratio on the packaging of the cleaning agents.
- Do not use highly acidic or alkaline cleaning agents.

## WASHING YOUR MOTORCYCLE

BMW Motorrad recommends that you use BMW Insect Remover to soften and wash off insects and stubborn dirt from painted parts before washing the motorcycle.

To prevent stains, do not wash the vehicle immediately after it has been exposed to bright sunlight and do not wash it in the sun.

Make sure that the vehicle is washed frequently, especially during the winter months.

To remove road salt, clean the motorcycle with cold water immediately after completion of every trip.



### WARNING

#### Damp brake disks and brake pads after washing the motorcycle, after riding through water or in the rain

Poorer braking action, accident hazard

- Brake early until the brake rotors and brake pads are dry.

**ATTENTION****Increased effect of salt caused by warm water**

Corrosion

- Only use cold water to remove road salt.

**ATTENTION****Damage caused by high water pressure from high-pressure cleaners or steam-jet devices**

Corrosion or short circuit, damage to labels, to seals, to hydraulic brake system, to the electrical system and the seat

- Exercise caution when using high-pressure or steam-jet devices.

**CLEANING SENSITIVE MOTORCYCLE PARTS****Plastics****ATTENTION****Use of unsuitable cleaning agents**

Damage to plastic surfaces

- Do not use abrasive cleaners or cleaners containing alcohol or solvents.
- Do not use insect sponges or sponges with a hard surface.

**Trim panel components**

Clean trim panel components with water and BMW Motorrad cleaning agent.

**Headlight diffuser and turn indicator glass made of plastic**

Clean off dirt and insects with a soft sponge and plenty of water.



Soften stubborn dirt and dead insects by covering the affected areas with a wet cloth.



Clean with water and sponge only.

## 152 CARE



Do not use chemical cleaning agents.

### Chrome

Carefully clean chrome parts with plenty of water and BMW Motorrad Care Products motorcycle cleaner. This is particularly important in the case of road salt.

Use BMW Motorrad metal polish for additional treatment.

### Radiator

Clean the radiator regularly to prevent overheating of the engine due to inadequate cooling. For example, use a garden hose with low water pressure.



### ATTENTION

#### Bending of radiator fins

Damage to radiator fins

- When cleaning, ensure that the cooler fins are not bent.

### Rubber

Treat rubber parts with water or BMW rubber care product.



### ATTENTION

#### Use of silicone sprays for care of rubber seals

Damage to rubber seals

- Do not use silicone sprays or care products that contain silicone.

### PAINT CARE

Washing the motorcycle regularly will help counteract the long-term effects of substances that damage the paint, especially if your motorcycle is ridden in areas with high air pollution or natural sources of dirt, such as tree resin or pollen. However, remove particularly aggressive materials immediately; otherwise changes in the paint or discoloration can occur. These include spilled fuel, oil, grease and brake fluid as well as bird droppings. BMW Motorrad recommends using a solvent cleaner and then applying a BMW Motorrad high gloss polish to preserve the paint.

Contamination on the paint finish is particularly easy to see after the motorcycle has been washed. Remove this type of soiling with cleaning naphtha

or spirit on a clean cloth or cotton ball. BMW Motorrad recommends removing tar stains with BMW tar remover. Then add a protective wax coating to the paint at these locations.

---

## PAINT PRESERVATION

Apply a preservative when water fails to bead up on the painted surface.

BMW Motorrad recommends BMW Motorrad high gloss polish or agents that contain carnauba or synthetic wax for paint preservation.

---

## STORING THE MOTORCYCLE

- Completely fill the motorcycle's fuel tank.



Fuel additives clean the fuel injection system and the combustion area. Fuel additives should be used when refueling with low-quality fuels or during longer periods of downtime. Your authorized BMW Motorrad retailer can provide you with more detailed information.

- Clean the motorcycle.
- Remove battery.
- Spray brake lever and clutch lever as well as side stand pivots with a suitable lubricant.

- Coat bare metal and chrome plated parts with an acid-free grease (petroleum jelly).
- Park motorcycle in a dry room, raising it to relieve weight from both wheels (preferably using the front-wheel and rear-wheel stands offered by BMW Motorrad).

---

## PUTTING THE MOTORCYCLE INTO OPERATION

- Remove the protective wax coating.
- Clean the motorcycle.
- Install the battery.
- Checklist (▶▶▶ 82).

# TECHNICAL DATA

11



---

<b>TROUBLESHOOTING CHART</b>	<b>156</b>
<b>SCREW CONNECTIONS</b>	<b>157</b>
<b>FUEL</b>	<b>160</b>
<b>ENGINE OIL</b>	<b>160</b>
<b>ENGINE</b>	<b>161</b>
<b>CLUTCH</b>	<b>162</b>
<b>TRANSMISSION</b>	<b>162</b>
<b>REAR-WHEEL DRIVE</b>	<b>162</b>
<b>FRAME</b>	<b>162</b>
<b>CHASSIS</b>	<b>163</b>
<b>BRAKES</b>	<b>164</b>
<b>WHEELS AND TIRES</b>	<b>164</b>
<b>ELECTRICAL SYSTEM</b>	<b>165</b>
<b>DIMENSIONS</b>	<b>166</b>
<b>WEIGHTS</b>	<b>167</b>
<b>PERFORMANCE DATA</b>	<b>167</b>

# 156 TECHNICAL DATA

---

## TROUBLESHOOTING CHART

Engine does not start at all or is very difficult to start.

Possible cause	Remedy
Emergency on/off switch (kill switch)	Emergency off switch in normal operating position
Side stand is extended and gear is engaged.	Fold in side stand.
Gear is engaged and clutch is not operated.	Shift transmission to neutral or disengage clutch.
Fuel tank is empty.	Refueling procedure (▶▶▶ 91).
Battery is drained.	Charging a connected battery (▶▶▶ 132).
Overheating protection for starter motor has activated. Starter motor can only be actuated for a limited period.	Leave the starter motor to cool down for around 1 minute until it becomes available again.

---

**SCREW CONNECTIONS**

<b>Front wheel</b>	<b>Value</b>	<b>Valid</b>
<b>Brake caliper on telescopic forks</b>		
M10 x 65	28 lb/ft (38 Nm)	
<b>Clamping bolts in axle mount</b>		
M8 x 35	<b>Tightening sequence:</b> <b>Tighten the screws 6 times, alternating between one and the other each time</b>	
	14 lb/ft (19 Nm)	
<b>Screw in quick-release axle</b>		
M20 x 1.5 18	37 lb/ft (50 Nm)	
<b>Rear wheel</b>	<b>Value</b>	<b>Valid</b>
<b>Rear wheel on wheel carrier</b>		
M10 x 53 x 1.25	<b>Tightening sequence:</b> <b>Tighten crosswise</b>	
	44 lb/ft (60 Nm)	
<b>Mirror arm</b>	<b>Value</b>	<b>Valid</b>
<b>Mirror (locknut) on adapter</b>		
M10 x 1.25	Left-hand thread, 16 lb/ft (22 Nm)	
<b>Adapter to clamping block</b>		
M10 x 14 - 4.8	18 lb/ft (25 Nm)	

# 158 TECHNICAL DATA

Mirror arm	Value	Valid
<b>Mirror on spacer sleeve</b>		
M5 x 20	2 lb/ft (3 Nm)	-with Option 719 Milled Parts Set Classic II <sup>OE</sup> or -with Option 719 Milled Parts Set Shadow II <sup>OE</sup>

Headlight	Value	Valid
<b>Headlight on bracket</b>		
M8 x 40	14 lb/ft (19 Nm)	

Front wheel cover	Value	Valid
<b>Front wheel cover on fork</b>		
M5 x 20	4 lb/ft (5 Nm)	

Frame	Value	Valid
<b>Footrest system on rear frame</b>		
M8 x 25	14 lb/ft (19 Nm)	
<b>Passenger seat frame on rear frame</b>		
M8 x 30	14 lb/ft (19 Nm)	
<b>Passenger seat from on luggage frame</b>		
M6 x 20	6 lb/ft (8 Nm)	

<b>Frame</b>	<b>Value</b>	<b>Valid</b>
<b>Retaining bridge on rear frame</b>		
M6 x 14.5	6 lb/ft (8 Nm)	
<b>Exhaust system</b>	<b>Value</b>	<b>Valid</b>
<b>Clamp on silencer and exhaust manifold</b>		
M8 x 40 - 10.9	21 lb/ft (28 Nm)	
<b>Silencer on passenger frame</b>		
M8 x 40	14 lb/ft (19 Nm)	
<b>Bracket for silencer on rear frame</b>		
M8 x 30	14 lb/ft (19 Nm)	-with carrier for silencer <sup>OA</sup>
M8 x 25	14 lb/ft (19 Nm)	
<b>Silencer on bracket</b>		
M8 x 40	7 lb/ft (10 Nm)	-with carrier for silencer <sup>OA</sup>

# 160 TECHNICAL DATA

## FUEL

Recommended fuel quality	Super unleaded (max. 15% ethanol, E15) 89 AKI (95 ROZ/RON) 90 AKI
Alternative fuel quality	Regular unleaded (max. 15% ethanol, E15) 87 AKI (91 ROZ/RON) 87 AKI
Usable fuel quantity	Approx. 4.8 gal (Approx. 18 l)
Reserve fuel quantity	Approx. 3.7 quarts (Approx. 3.5 l)
Fuel consumption	46 mpg (5.1 l/100 km), in accordance with WMTC
CO2 emissions	119 g/km, in accordance with WMTC
Emission standard	TIER 2, measured in accordance with FTP75

## ENGINE OIL

Engine oil, capacity	max 1 gal (max 3.95 l), with filter replacement
Specification	SAE 15W-50, API SJ/ JASO MA2, Additives (for instance, molybdenum-based substances) are prohibited, because they would attack the coatings on engine components, BMW Motorrad recommends BMW Motorrad ADVANTEC Pro Oil

Engine oil, quantity for topping up	max 0.5 quarts (max 0.5 l), Difference between MIN and MAX
-------------------------------------	--

**BMW recommends** **ADVANTEC**  
ORIGINAL BMW ENGINE OIL

## ENGINE

Engine number location	On crankcase at lower right, below cylinder
Engine type	A72B12A
Engine design	Longitudinally mounted two-cylinder opposed-twin engine with two overhead camshafts each, four radially arranged valves per cylinder, air cooling, oil-cooled outlet area and electronic engine management
Displacement	1170 cc (1170 cm <sup>3</sup> )
Cylinder bore	4 in (101 mm)
Piston stroke	2.9 in (73 mm)
Compression ratio	12.0:1
Nominal capacity	107 hp (80 kW), at RPM: 7250 min <sup>-1</sup>
Torque	86 lb/ft (116 Nm), at engine speed: 6000 min <sup>-1</sup>
Maximum engine speed	max 8500 min <sup>-1</sup>
Idle speed	1150 <sup>±50</sup> min <sup>-1</sup> , Engine at operating temperature

## 162 TECHNICAL DATA

---

### CLUTCH

Clutch design	Single-plate dry clutch
---------------	-------------------------

---

### TRANSMISSION

Transmission design	Dog-engagement 6-speed manual transmission with helical gears
Transmission gear ratios	1.737, Primary gear ratio 2.375 (38:16 teeth), 1st gear 1.696 (39:23 teeth), 2nd gear 1.296 (35:27 teeth), 3rd gear 1.065 (33:31 teeth), 4th gear 0.939 (31:33 teeth), 5th gear 0.848 (28:33 teeth), 6th gear

---

### REAR-WHEEL DRIVE

Type of final drive	Cardan shaft drive with bevel gears
Type of rear-wheel guide	Cast aluminum single-sided swinging arm with BMW Motorrad Paralever
Gear ratio of rear-wheel drive	2.910 (32/11 teeth)
Rear axle differential oil	SAE 70W-80 / hypoid axle G3

---

### FRAME

Frame design	Lattice-tube frame with supporting drive unit
Location of type plate	Frame at front left on steering head
Location of the vehicle identification number	Main frame at lower front right



---

**CHASSIS**

---

**Front wheel**

Type of front suspension	Upside down telescopic forks, diameter 46 mm, adjustable rebound and compression stage
Spring travel, front	4.7 in (120 mm), on wheel

**Rear wheel**

Type of rear-wheel guide	Cast aluminum single-sided swinging arm with BMW Motorrad Paralever
Design of rear-wheel suspension	Central spring strut with coil spring, adjustable rebound-stage damping and spring preload
Spring travel on the rear wheel	4.7 in (120 mm), on wheel
Recommendation on chassis and suspension adjustment for one-up operation	Spring preload, Turn adjustment wheel counterclockwise as far as possible Damping, Turn adjusting screw as far as possible clockwise, then turn back 1.5 turns
Recommendation on chassis and suspension adjustment for two-up mode	Spring preload, Turn adjustment wheel clockwise up to stop Damping, Turn adjustment wheel clockwise up to stop, then turn back by 0.75 turns

---

## 164 TECHNICAL DATA

### BRAKES

#### Front wheel

Type of front wheel brake	Twin disc brake with 4-piston fixed caliper
Front brake pad material	Sintered metal
Front brake disc thickness	min 0.16 in (min 4 mm), Wear limit
Free travel of brake actuation (Front wheel brake)	0.03...0.07 in (0.7...1.7 mm), at piston

#### Rear wheel

Type of rear wheel brake	Single-disc brake with 2-piston floating caliper
Rear brake pad material	Organic
Rear brake disc thickness	min 0.18 in (min 4.5 mm), Wear limit
Free travel of brake actuation (Rear wheel brake)	0.02...0.04 in (0.5...0.9 mm), at piston

### WHEELS AND TIRES

Recommended tire combinations	An overview of the current tire approvals is available from your authorized BMW Motorrad retailer or on the Internet at <a href="http://bmw-motorrad.com">bmw-motorrad.com</a> .
Speed category of front/rear tires	V, minimum requirement: 149 mph (240 km/h)

**Front wheel**

Front wheel design	Spoked wheel
Front-wheel rim size	3.50" x 17"
Front tire designation	120 / 70 ZR 17
Load index for front tire	At least 58
Permitted front wheel imbalance	max 0.2 oz (max 5 g)

**Rear wheel**

Rear wheel design	Spoked wheel
Rear-wheel rim size	5.50" x 17"
Rear tire designation	180 / 55 ZR 17
Load index for rear tire	At least 73
Permitted rear wheel imbalance	max 0.2 oz (max 5 g)

**Tire pressures**

Front tire pressure	36.3 psi (2.5 bar), with tire cold
Rear tire pressure	39.2 psi (2.7 bar), One-up, with cold tires 42.1 psi (2.9 bar), Two-up and cargo, with cold tires

**ELECTRICAL SYSTEM****Fuses**

Fuse 1	10 A, Instrument cluster, anti-theft alarm system DWA, ignition switch, OBD diagnostic socket, coil for cut-off relay
Fuse 2	4 A, Sensor box, multifunction switch on left

## 166 TECHNICAL DATA

---

### Battery

Battery design	AGM battery (Absorbent Glass Mat)
Battery voltage	12 V
Battery capacity	14 Ah

### Spark plugs

Spark plugs, manufacturer and designation	NGK MAR8AI-10DS
---	-----------------

### Light sources

Bulb for low-beam and high-beam headlight	LED
Bulb for parking light	LED
Bulb for taillight/brake light	LED
Bulbs for flashing turn indicators	LED
Light source for license plate light	LED

---

### DIMENSIONS

Motorcycle length	82.9 in (2105 mm), measured over rear wheel
Motorcycle height	48.8 in (1240 mm), with mirror, at DIN unloaded vehicle weight
Motorcycle width	34.1 in (865 mm), using handlebar levers
Front-seat height	31.7 in (805 mm), without rider, at DIN unloaded vehicle weight
Rider's inside-leg arc, heel to heel	70.3 in (1785 mm), without rider, at DIN unloaded vehicle weight

---

---

**WEIGHTS**

---

Unloaded vehicle weight	489 lbs (222 kg), DIN unloaded vehicle weight, ready for road, 90% full tank of gas, without OE
Gross vehicle weight	948 lbs (430 kg)
Maximum payload	459 lbs (208 kg)

---

**PERFORMANCE DATA**

---

Maximum speed	>124 mph (>200 km/h)
---------------	----------------------

---

**SERVICE**

**12**

---

<b>REPORTING SAFETY DEFECTS</b>	<b>170</b>
<b>BMW MOTORRAD SERVICE</b>	<b>171</b>
<b>BMW MOTORRAD ELECTRONIC SERVICE HISTORY (ESH)</b>	<b>171</b>
<b>BMW MOTORRAD MOBILITY SERVICES</b>	<b>172</b>
<b>MAINTENANCE WORK</b>	<b>172</b>
<b>MAINTENANCE SCHEDULE</b>	<b>174</b>
<b>MAINTENANCE CONFIRMATIONS</b>	<b>175</b>
<b>SERVICE CONFIRMATIONS</b>	<b>189</b>

### REPORTING SAFETY DEFECTS

If you think that your motorcycle has a fault which may cause an accident, injury or death, you must inform the NHTSA (National Highway Traffic Safety Administration) immediately and BMW of North America, LLC.

If the NHTSA receives other similar complaints, it may open an investigation. If it finds that a safety defect exists in a group of vehicles, the NHTSA may order the manufacturer to perform a recall and remedy campaign. However, the NHTSA cannot become involved in individual problems between you, your authorized BMW Motorrad retailer, or BMW of North America, LLC. You can contact the NHTSA by calling the Vehicle Safety Hotline on 1-888-327-4236 (Teletypewriter TTY for the hearing impaired: 1-800-424-9153) for free, by visiting the website at [http:// www.safercar.gov](http://www.safercar.gov) or by writing to Administrator, NHTSA, 400 Seventh Street, SW., Washington, DC 20590. Further information on vehicle safety is available at [http:// www.safercar.gov](http://www.safercar.gov). Canadian customers who wish to report a safetyrelated defect to Transport Canada, Defect Investigations and Recalls, may call the toll-free hotline 1-800-333-0510. You can also obtain other information about motor vehicle safety from [http:// www.tc.gc.ca/roadsafety](http://www.tc.gc.ca/roadsafety).



---

## BMW MOTORRAD SERVICE

With its worldwide retailer network, BMW Motorrad can attend to you and your motorcycle in over 100 countries around the globe. Authorized BMW Motorrad retailers have the technical information and expertise needed to reliably conduct all preventive maintenance and repair tasks on your BMW.

You will find the nearest authorized BMW Motorrad retailer to you at our website:  
**bmw-motorrad.com**



### WARNING

#### Improperly performed maintenance and repair work

Accident hazard caused by subsequent damage

- BMW Motorrad recommends having corresponding work on the motorcycle carried out by a specialized workshop, preferably by an authorized BMW Motorrad retailer.

To ensure that your BMW is always in optimal condition, BMW Motorrad advises that you observe the recommended

service intervals for your motorcycle.

Have all maintenance and repair tasks confirmed in the Service chapter in this manual. Documented proof of scheduled preventive maintenance is essential for generous treatment of claims submitted after the warranty period has expired (goodwill).

You can obtain information on the contents of the BMW Services from your BMW Motorrad retailer.

---

## BMW MOTORRAD ELECTRONIC SERVICE HISTORY (ESH)

### Entries

Maintenance work that has been performed is recorded in the diagnostics and information system. Like a Service Booklet, these entries provide proof of regular maintenance.

If an entry is made in the vehicle's eSH, service-related data is stored on the central IT systems of BMW AG in Munich, Germany.

When there is a change in vehicle owner, the data entered in the eSH can also be viewed by the new vehicle owner. A BMW Motorrad retailer or spe-

## 172 SERVICE

cialist workshop can view the data entered in the electronic Service Manual.

### **Objection**

At the BMW Motorrad retailer or specialist workshop, the vehicle owner can object to the entry of data in the electronic Service Manual with the related storage of data in the vehicle and the transfer of data to the vehicle manufacturer during his time as the vehicle owner. In this case, no entry is made in the vehicle's electronic Service Manual.

---

### **BMW MOTORRAD MOBILITY SERVICES**

As the owner of a new BMW motorcycle, you can benefit from the protection afforded by the various BMW Motorrad mobility services in the event of a breakdown (e.g., BMW Roadside Assistance, breakdown service, vehicle recovery service).

Contact your authorized BMW Motorrad retailer for additional information on available mobility services.

---

### **MAINTENANCE WORK**

#### **BMW pre-delivery check**

The BMW pre-delivery check is carried out by your authorized BMW Motorrad retailer before it turns the motorcycle over to you.

#### **BMW running-in check**

The BMW running-in check must be performed when the motorcycle has covered between 300 mi and 750 mi (500 km and 1200 km).

#### **BMW Service**

BMW service is carried out once a year. The scope of the services performed may be dependent on the vehicle owner and the mileage driven. Your BMW Motorrad retailer confirms that the service has been performed and enters the date for the next service.

For riders who drive long distances annually, it may be necessary to come in for service before the entered date. In this case a corresponding maximum odometer reading will also be entered in the confirmation of service. If this odometer reading is reached before the next service date, service must be performed sooner.

The service display in the multi-function display reminds you of the next service date approx. one month or 620 miles (1000 km) before the entered values.

More information on the topic of service is available at:  
**[bmw-motorrad.com/service](http://bmw-motorrad.com/service)**

The required scope of maintenance work for your motorcycle can be found in the following maintenance schedule:

# 174 SERVICE

## MAINTENANCE SCHEDULE

	500 -1200 km 300 - 750 mls	10 000 km 6 000 mls	20 000 km 12 000 mls	30 000 km 18 000 mls	40 000 km 24 000 mls	50 000 km 30 000 mls	60 000 km 36 000 mls	70 000 km 42 000 mls	80 000 km 48 000 mls	90 000 km 54 000 mls	100 000 km 60 000 mls	12 months	24 months
1	X												
2												X	
3		X	X	X	X	X	X	X	X	X	X	X <sup>a</sup>	
4			X		X		X		X		X		X <sup>b</sup>
5		X	X	X	X	X	X	X	X	X	X		
6					X				X			X <sup>c</sup>	X <sup>c</sup>
7			X		X		X		X		X		
8			X		X		X		X		X		
9					X <sup>d</sup>				X <sup>d</sup>				
10				X			X			X			
11												X <sup>e</sup>	X <sup>e</sup>

- 1 BMW Running-in check (including oil change)
- 2 Standard scope of BMW Service
- 3 Engine oil change using filter
- 4 Oil change in the bevel gears rear
- 5 Check valve clearance
- 6 Change transmission oil
- 7 Replace all spark plugs
- 8 Replace the air filter insert
- 9 Replace the alternator belt
- 10 Oil change in the telescopic forks
- 11 Change brake fluid in the entire system

a annually or every 6000 mi (10000 km) (whichever comes first)

b annually or every 12000 mi (20000 km) (whichever comes first)

c for the first time after one year, then every two years or 24000 mi (40000 km) (whichever comes first)

d every six years or every 24000 mi (40000 km) (whichever comes first)

e at first after one year, then every two years

---

## MAINTENANCE CONFIRMATIONS

### BMW Service standard scope

The repair procedures belonging to the BMW Service standard package are listed below. The actual maintenance work applicable for your vehicle may differ.

- Performing the vehicle test using the BMW Motorrad diagnostic system
- Visual inspection of the clutch system
- Checking steering-head bearing
- Visual inspection of the brake lines, brake hoses, and connections
- Checking the front brake pads and brake discs for wear
- Checking the front wheel brake fluid level
- Checking the rear brake pads and brake disc for wear
- Checking the rear wheel brake fluid level
- Checking the tire pressure and tread depth
- Check side stand for ease of movement
- Check the tension of the spokes and tighten as needed
- Checking the lighting and signal system
- Functional check for engine starting suppression
- Final inspection and road safety check
- Set the service date and remaining distance using the BMW Motorrad diagnostic system
- Checking charging state of battery
- Confirm the BMW service in the vehicle literature

# 176 SERVICE

**BMW pre-delivery check**  
performed

on \_\_\_\_\_

Stamp, signature

**BMW Running-in Check**  
performed

on \_\_\_\_\_

Odometer reading \_\_\_\_\_

Next service

latest

on \_\_\_\_\_

or, if reached earlier

Odometer reading \_\_\_\_\_

Stamp, signature

**BMW Service**

performed

on \_\_\_\_\_

Odometer reading \_\_\_\_\_

Next service

latest

on \_\_\_\_\_

or, if reached earlier

Odometer reading \_\_\_\_\_

## Work performed

	Yes	No
BMW Service	<input type="checkbox"/>	<input type="checkbox"/>
Engine oil change with filter	<input type="checkbox"/>	<input type="checkbox"/>
Oil change in rear bevel gears	<input type="checkbox"/>	<input type="checkbox"/>
Checking valve clearance	<input type="checkbox"/>	<input type="checkbox"/>
Changing gear oil	<input type="checkbox"/>	<input type="checkbox"/>
Replacing all spark plugs	<input type="checkbox"/>	<input type="checkbox"/>
Replacing air cleaner element	<input type="checkbox"/>	<input type="checkbox"/>
Replacing alternator drive belt	<input type="checkbox"/>	<input type="checkbox"/>
Oil change - telescopic fork	<input type="checkbox"/>	<input type="checkbox"/>
Changing front brake fluid	<input type="checkbox"/>	<input type="checkbox"/>
Changing brake fluid, rear	<input type="checkbox"/>	<input type="checkbox"/>

Information

Stamp, signature

# 178 SERVICE

## BMW Service

performed

on \_\_\_\_\_

Odometer reading \_\_\_\_\_

## Next service

latest

on \_\_\_\_\_

or, if reached earlier

Odometer reading \_\_\_\_\_

## Work performed

	Yes	No
BMW Service	<input type="checkbox"/>	<input type="checkbox"/>
Engine oil change with filter	<input type="checkbox"/>	<input type="checkbox"/>
Oil change in rear bevel gears	<input type="checkbox"/>	<input type="checkbox"/>
Checking valve clearance	<input type="checkbox"/>	<input type="checkbox"/>
Changing gear oil	<input type="checkbox"/>	<input type="checkbox"/>
Replacing all spark plugs	<input type="checkbox"/>	<input type="checkbox"/>
Replacing air cleaner element	<input type="checkbox"/>	<input type="checkbox"/>
Replacing alternator drive belt	<input type="checkbox"/>	<input type="checkbox"/>
Oil change - telescopic fork	<input type="checkbox"/>	<input type="checkbox"/>
Changing front brake fluid	<input type="checkbox"/>	<input type="checkbox"/>
Changing brake fluid, rear	<input type="checkbox"/>	<input type="checkbox"/>

Information

Stamp, signature



**BMW Service**

performed

on \_\_\_\_\_

Odometer reading \_\_\_\_\_

Next service

latest

on \_\_\_\_\_

or, if reached earlier

Odometer reading \_\_\_\_\_

## Work performed

	Yes	No
BMW Service	<input type="checkbox"/>	<input type="checkbox"/>
Engine oil change with filter	<input type="checkbox"/>	<input type="checkbox"/>
Oil change in rear bevel gears	<input type="checkbox"/>	<input type="checkbox"/>
Checking valve clearance	<input type="checkbox"/>	<input type="checkbox"/>
Changing gear oil	<input type="checkbox"/>	<input type="checkbox"/>
Replacing all spark plugs	<input type="checkbox"/>	<input type="checkbox"/>
Replacing air cleaner element	<input type="checkbox"/>	<input type="checkbox"/>
Replacing alternator drive belt	<input type="checkbox"/>	<input type="checkbox"/>
Oil change - telescopic fork	<input type="checkbox"/>	<input type="checkbox"/>
Changing front brake fluid	<input type="checkbox"/>	<input type="checkbox"/>
Changing brake fluid, rear	<input type="checkbox"/>	<input type="checkbox"/>

Information

Stamp, signature

# 180 SERVICE

## BMW Service

performed

on \_\_\_\_\_

Odometer reading \_\_\_\_\_

### Next service

latest

on \_\_\_\_\_

or, if reached earlier

Odometer reading \_\_\_\_\_

## Work performed

	Yes	No
BMW Service	<input type="checkbox"/>	<input type="checkbox"/>
Engine oil change with filter	<input type="checkbox"/>	<input type="checkbox"/>
Oil change in rear bevel gears	<input type="checkbox"/>	<input type="checkbox"/>
Checking valve clearance	<input type="checkbox"/>	<input type="checkbox"/>
Changing gear oil	<input type="checkbox"/>	<input type="checkbox"/>
Replacing all spark plugs	<input type="checkbox"/>	<input type="checkbox"/>
Replacing air cleaner element	<input type="checkbox"/>	<input type="checkbox"/>
Replacing alternator drive belt	<input type="checkbox"/>	<input type="checkbox"/>
Oil change - telescopic fork	<input type="checkbox"/>	<input type="checkbox"/>
Changing front brake fluid	<input type="checkbox"/>	<input type="checkbox"/>
Changing brake fluid, rear	<input type="checkbox"/>	<input type="checkbox"/>

Information

Stamp, signature

**BMW Service**

performed

on \_\_\_\_\_

Odometer reading \_\_\_\_\_

Next service

latest

on \_\_\_\_\_

or, if reached earlier

Odometer reading \_\_\_\_\_

## Work performed

	Yes	No
BMW Service	<input type="checkbox"/>	<input type="checkbox"/>
Engine oil change with filter	<input type="checkbox"/>	<input type="checkbox"/>
Oil change in rear bevel gears	<input type="checkbox"/>	<input type="checkbox"/>
Checking valve clearance	<input type="checkbox"/>	<input type="checkbox"/>
Changing gear oil	<input type="checkbox"/>	<input type="checkbox"/>
Replacing all spark plugs	<input type="checkbox"/>	<input type="checkbox"/>
Replacing air cleaner element	<input type="checkbox"/>	<input type="checkbox"/>
Replacing alternator drive belt	<input type="checkbox"/>	<input type="checkbox"/>
Oil change - telescopic fork	<input type="checkbox"/>	<input type="checkbox"/>
Changing front brake fluid	<input type="checkbox"/>	<input type="checkbox"/>
Changing brake fluid, rear	<input type="checkbox"/>	<input type="checkbox"/>

Information

Stamp, signature

# 182 SERVICE

## BMW Service

performed

on \_\_\_\_\_

Odometer reading \_\_\_\_\_

### Next service

latest

on \_\_\_\_\_

or, if reached earlier

Odometer reading \_\_\_\_\_

## Work performed

	Yes	No
BMW Service	<input type="checkbox"/>	<input type="checkbox"/>
Engine oil change with filter	<input type="checkbox"/>	<input type="checkbox"/>
Oil change in rear bevel gears	<input type="checkbox"/>	<input type="checkbox"/>
Checking valve clearance	<input type="checkbox"/>	<input type="checkbox"/>
Changing gear oil	<input type="checkbox"/>	<input type="checkbox"/>
Replacing all spark plugs	<input type="checkbox"/>	<input type="checkbox"/>
Replacing air cleaner element	<input type="checkbox"/>	<input type="checkbox"/>
Replacing alternator drive belt	<input type="checkbox"/>	<input type="checkbox"/>
Oil change - telescopic fork	<input type="checkbox"/>	<input type="checkbox"/>
Changing front brake fluid	<input type="checkbox"/>	<input type="checkbox"/>
Changing brake fluid, rear	<input type="checkbox"/>	<input type="checkbox"/>

Information

Stamp, signature

**BMW Service**

performed

on \_\_\_\_\_

Odometer reading \_\_\_\_\_

Next service

latest

on \_\_\_\_\_

or, if reached earlier

Odometer reading \_\_\_\_\_

## Work performed

	Yes	No
BMW Service	<input type="checkbox"/>	<input type="checkbox"/>
Engine oil change with filter	<input type="checkbox"/>	<input type="checkbox"/>
Oil change in rear bevel gears	<input type="checkbox"/>	<input type="checkbox"/>
Checking valve clearance	<input type="checkbox"/>	<input type="checkbox"/>
Changing gear oil	<input type="checkbox"/>	<input type="checkbox"/>
Replacing all spark plugs	<input type="checkbox"/>	<input type="checkbox"/>
Replacing air cleaner element	<input type="checkbox"/>	<input type="checkbox"/>
Replacing alternator drive belt	<input type="checkbox"/>	<input type="checkbox"/>
Oil change - telescopic fork	<input type="checkbox"/>	<input type="checkbox"/>
Changing front brake fluid	<input type="checkbox"/>	<input type="checkbox"/>
Changing brake fluid, rear	<input type="checkbox"/>	<input type="checkbox"/>

Information

Stamp, signature

# 184 SERVICE

## BMW Service

performed

on \_\_\_\_\_

Odometer reading \_\_\_\_\_

### Next service

latest

on \_\_\_\_\_

or, if reached earlier

Odometer reading \_\_\_\_\_

## Work performed

	Yes	No
BMW Service	<input type="checkbox"/>	<input type="checkbox"/>
Engine oil change with filter	<input type="checkbox"/>	<input type="checkbox"/>
Oil change in rear bevel gears	<input type="checkbox"/>	<input type="checkbox"/>
Checking valve clearance	<input type="checkbox"/>	<input type="checkbox"/>
Changing gear oil	<input type="checkbox"/>	<input type="checkbox"/>
Replacing all spark plugs	<input type="checkbox"/>	<input type="checkbox"/>
Replacing air cleaner element	<input type="checkbox"/>	<input type="checkbox"/>
Replacing alternator drive belt	<input type="checkbox"/>	<input type="checkbox"/>
Oil change - telescopic fork	<input type="checkbox"/>	<input type="checkbox"/>
Changing front brake fluid	<input type="checkbox"/>	<input type="checkbox"/>
Changing brake fluid, rear	<input type="checkbox"/>	<input type="checkbox"/>

Information

Stamp, signature

**BMW Service**

performed

on \_\_\_\_\_

Odometer reading \_\_\_\_\_

Next service

latest

on \_\_\_\_\_

or, if reached earlier

Odometer reading \_\_\_\_\_

## Work performed

	Yes	No
BMW Service	<input type="checkbox"/>	<input type="checkbox"/>
Engine oil change with filter	<input type="checkbox"/>	<input type="checkbox"/>
Oil change in rear bevel gears	<input type="checkbox"/>	<input type="checkbox"/>
Checking valve clearance	<input type="checkbox"/>	<input type="checkbox"/>
Changing gear oil	<input type="checkbox"/>	<input type="checkbox"/>
Replacing all spark plugs	<input type="checkbox"/>	<input type="checkbox"/>
Replacing air cleaner element	<input type="checkbox"/>	<input type="checkbox"/>
Replacing alternator drive belt	<input type="checkbox"/>	<input type="checkbox"/>
Oil change - telescopic fork	<input type="checkbox"/>	<input type="checkbox"/>
Changing front brake fluid	<input type="checkbox"/>	<input type="checkbox"/>
Changing brake fluid, rear	<input type="checkbox"/>	<input type="checkbox"/>

Information

Stamp, signature

# 186 SERVICE

## BMW Service

performed

on \_\_\_\_\_

Odometer reading \_\_\_\_\_

### Next service

latest

on \_\_\_\_\_

or, if reached earlier

Odometer reading \_\_\_\_\_

## Work performed

	Yes	No
BMW Service	<input type="checkbox"/>	<input type="checkbox"/>
Engine oil change with filter	<input type="checkbox"/>	<input type="checkbox"/>
Oil change in rear bevel gears	<input type="checkbox"/>	<input type="checkbox"/>
Checking valve clearance	<input type="checkbox"/>	<input type="checkbox"/>
Changing gear oil	<input type="checkbox"/>	<input type="checkbox"/>
Replacing all spark plugs	<input type="checkbox"/>	<input type="checkbox"/>
Replacing air cleaner element	<input type="checkbox"/>	<input type="checkbox"/>
Replacing alternator drive belt	<input type="checkbox"/>	<input type="checkbox"/>
Oil change - telescopic fork	<input type="checkbox"/>	<input type="checkbox"/>
Changing front brake fluid	<input type="checkbox"/>	<input type="checkbox"/>
Changing brake fluid, rear	<input type="checkbox"/>	<input type="checkbox"/>

Information

Stamp, signature



**BMW Service**

performed

on \_\_\_\_\_

Odometer reading \_\_\_\_\_

Next service

latest

on \_\_\_\_\_

or, if reached earlier

Odometer reading \_\_\_\_\_

## Work performed

	Yes	No
BMW Service	<input type="checkbox"/>	<input type="checkbox"/>
Engine oil change with filter	<input type="checkbox"/>	<input type="checkbox"/>
Oil change in rear bevel gears	<input type="checkbox"/>	<input type="checkbox"/>
Checking valve clearance	<input type="checkbox"/>	<input type="checkbox"/>
Changing gear oil	<input type="checkbox"/>	<input type="checkbox"/>
Replacing all spark plugs	<input type="checkbox"/>	<input type="checkbox"/>
Replacing air cleaner element	<input type="checkbox"/>	<input type="checkbox"/>
Replacing alternator drive belt	<input type="checkbox"/>	<input type="checkbox"/>
Oil change - telescopic fork	<input type="checkbox"/>	<input type="checkbox"/>
Changing front brake fluid	<input type="checkbox"/>	<input type="checkbox"/>
Changing brake fluid, rear	<input type="checkbox"/>	<input type="checkbox"/>

Information

Stamp, signature

# 188 SERVICE

## BMW Service

performed

on \_\_\_\_\_

Odometer reading \_\_\_\_\_

### Next service

latest

on \_\_\_\_\_

or, if reached earlier

Odometer reading \_\_\_\_\_

## Work performed

	Yes	No
BMW Service	<input type="checkbox"/>	<input type="checkbox"/>
Engine oil change with filter	<input type="checkbox"/>	<input type="checkbox"/>
Oil change in rear bevel gears	<input type="checkbox"/>	<input type="checkbox"/>
Checking valve clearance	<input type="checkbox"/>	<input type="checkbox"/>
Changing gear oil	<input type="checkbox"/>	<input type="checkbox"/>
Replacing all spark plugs	<input type="checkbox"/>	<input type="checkbox"/>
Replacing air cleaner element	<input type="checkbox"/>	<input type="checkbox"/>
Replacing alternator drive belt	<input type="checkbox"/>	<input type="checkbox"/>
Oil change - telescopic fork	<input type="checkbox"/>	<input type="checkbox"/>
Changing front brake fluid	<input type="checkbox"/>	<input type="checkbox"/>
Changing brake fluid, rear	<input type="checkbox"/>	<input type="checkbox"/>

Information

Stamp, signature







**CERTIFICATE FOR ELECTRONIC IMMOBILIZER  
DECLARATION OF CONFORMITY FOR ANTI-THEFT  
ALARM**

**193**

**195**

## FCC Approval

### Ring aerial in the ignition switch



To verify the authorization of the ignition key, the electronic immobilizer exchanges information with the ignition key via the ring aerial.

This device complies with Part 15 of the FCC rules. Operation is subject to the following two conditions:

- (1) This device may not cause harmful interference, and
- (2) this device must accept any interference received, including interference that may cause undesired operation.

 Any changes or modifications not expressly approved by the party responsible for compliance could void the user's authority to operate the equipment. ◀

## Approbation de la FCC

### Antenne annulaire présente dans le commutateur d'allumage



Pour vérifier l'autorisation de la clé de contact, le système d'immobilisation électronique échange des informations avec la clé de contact via l'antenne annulaire.

Le présent dispositif est conforme à la partie 15 des règles de la FCC. Son utilisation est soumise aux deux conditions suivantes :

- (1) Le dispositif ne doit pas produire d'interférences nuisibles, et
- (2) le dispositif doit pouvoir accepter toutes les interférences extérieures, y compris celles qui pourraient provoquer une activation inopportune.



Toute modification qui n'aurait qui n'aurait pas été approuvée expressément par l'organisme responsable de l'homologation peut annuler l'autorisation accordée à l'utilisateur pour utiliser le dispositif. ◀



# Declaration of Conformity

## Radio equipment anti-theft alarm (DWA)

Simplified EU Declaration of Conformity acc. Radio Equipment Directive 2014/53/EU after 12.06.2016 and during transition period



## Technical information

Frequency Band:  
433.05-434.79 MHz  
Output Power: 10 mW e.r.p.

## Manufacturer and Address

Manufacturer: Meta System S.p.A.  
Address: Via Galimberti 5 42124  
Reggio Emilia - Italy

## Austria

Hiermit erklärt Meta System S.p.A., dass der Funkanlagentyp TXBMWMR der Richtlinie 2014/53/EU entspricht. Der vollständige Text der EU-Konformitätserklärung ist unter der folgenden Internetadresse verfügbar: <https://docs.metasystem.it/>

## Belgium

Le soussigné, Meta System S.p.A., déclare que l'équipement radioélectrique du type TXBMWMR est conforme à la directive 2014/53/UE. Le texte complet de la déclaration UE de conformité est disponible à l'adresse internet suivante: <https://docs.metasystem.it/>

## Bulgaria

С настоящото Meta System S.p.A. декларира, че този тип радиосъоръжение TXBMWMR е в съответствие с Директива 2014/53/ЕС. Цялостният текст на ЕС декларацията за съответствие може да се намери на следния интернет адрес: <https://docs.metasystem.it/>

## Cyprus

Με την παρούσα ο/η Meta System S.p.A., δηλώνει ότι ο ραδιοεξοπλισμός TXBMWMR πληροί την οδηγία 2014/53/ΕΕ. Το πλήρες κείμενο της δήλωσης συμμόρφωσης ΕΕ διατίθεται στην ακόλουθη ιστοσελίδα στο διαδίκτυο: <https://docs.metasystem.it/>

## **Czech Republic**

Tímto Meta System S.p.A. prohlašuje, že typ rádiového zařízení TXBMWMMR je v souladu se směrnicí 2014/53/EU. Úplné znění EU prohlášení o shodě je k dispozici na této internetové adrese:  
<https://docs.metasystem.it/>

## **Germany**

Hiermit erklärt Meta System S.p.A., dass der Funkanlagentyp TXBMWMMR der Richtlinie 2014/53/EU entspricht. Der vollständige Text der EU-Konformitätserklärung ist unter der folgenden Internetadresse verfügbar:  
<https://docs.metasystem.it/>

## **Denmark**

Hermed erklærer Meta System S.p.A., at radioudstyrstypen TXBMWMMR er i overensstemmelse med direktiv 2014/53/EU. EU-overensstemmelseserklæringens fulde tekst kan findes på følgende internetadresse:  
<https://docs.metasystem.it/>

## **Estonia**

Käesolevaga deklareerib Meta System S.p.A., et käesolev raadioseadme tüüp TXBMWMMR vastab direktiivi 2014/53/EL nõuetele. ELi vastavusdeklaratsiooni täielik tekst on kättesaadav järgmisel internetiaadressil: <https://docs.metasystem.it/>

## **Spain**

Por la presente, Meta System S.p.A. declara que el tipo de equipo radioeléctrico TXBMWMMR es conforme con la Directiva 2014/53/UE. El texto completo de la declaración UE de conformidad está disponible en la dirección Internet siguiente: <https://docs.metasystem.it/>

## **Finland**

Meta System S.p.A. vakuuttaa, että radiolaitetyyppi TXBMWMMR on direktiivin 2014/53/EU mukainen. EU-vaatimustenmukaisuusvakuutuksen täysimittainen teksti on saatavilla seuraavassa internetosoitteessa: <https://docs.metasystem.it/>

## France

Le soussigné, Meta System S.p.A., déclare que l'équipement radioélectrique du type TXBMWMMR est conforme à la directive 2014/53/UE

Le texte complet de la déclaration UE de conformité est disponible à l'adresse internet suivante : <https://docs.metasystem.it/>

## United Kingdom

Hereby, Meta System S.p.A. declares that the radio equipment type TXBMWMMR is in compliance with Directive 2014/53/EU. The full text of the EU declaration of conformity is available at the following internet address: <https://docs.metasystem.it/>

## Greece

Με την παρούσα ο/η Meta System S.p.A., δηλώνει ότι ο ραδιοεξοπλισμός TXBMWMMR πληροί την οδηγία 2014/53/ΕΕ. Το πλήρες κείμενο της δήλωσης συμμόρφωσης ΕΕ διατίθεται στην ακόλουθη ιστοσελίδα στο διαδίκτυο: <https://docs.metasystem.it/>

## Croatia

Meta System S.p.A. ovime izjavljuje da je radijska oprema tipa TXBMWMMR u skladu s Direktivom 2014/53/EU. Cjeloviti tekst EU izjave o sukladnosti dostupan je na sljedećoj internetskoj adresi: <https://docs.metasystem.it/>

## Hungary

Meta System S.p.A. igazolja, hogy a TXBMWMMR típusú rádióberendezés megfelel a 2014/53/EU irányelvnek. Az EU-megfelelőségi nyilatkozat teljes szövege elérhető a következő internetes címen: <https://docs.metasystem.it/>

## Ireland

Hereby, Meta System S.p.A. declares that the radio equipment type TXBMWMMR is in compliance with Directive 2014/53/EU. The full text of the EU declaration of conformity is available at the following internet address: <https://docs.metasystem.it/>

## Italy

Il fabbricante, Meta System S.p.A., dichiara che il tipo di apparecchiatura radio TXBMWMMR è conforme alla direttiva 2014/53/UE. Il testo completo della dichiarazione di conformità UE è disponibile al seguente indirizzo Internet: <https://docs.metasystem.it/>

## **Lithuania**

Aš, Meta System S.p.A., patvirtinu, kad radijo įrenginių tipas TXBMWMMR atitinka Direktyvą 2014/53/ES.

Visas ES atitikties deklaracijos tekstas prieinamas šiuo interneto adresu: <https://docs.metasystem.it/>

## **Luxembourg**

Le soussigné, Meta System S.p.A., déclare que l'équipement radioélectrique du type TXBMWMMR est conforme à la directive 2014/53/UE.

Le texte complet de la déclaration UE de conformité est disponible à l'adresse internet suivante: <https://docs.metasystem.it/>

## **Latvia**

Ar šo Meta System S.p.A. deklarē, ka radioiekārta TXBMWMMR atbilst Direktīvai 2014/53/ES.

Pilns ES atbilstības deklarācijas teksts ir pieejams šādā interneta vietnē: <https://docs.metasystem.it/>

## **Malta**

B'dan, Meta System S.p.A., niddikjara li dan it-tip ta' tagħmir tar-radju TXBMWMMR huwa konformi mad-Direttiva 2014/53/UE.

It-test kollu tad-dikjarazzjoni ta' konformità tal-UE huwa disponibbli f'dan l-indirizz tal-Internet li ġej: <https://docs.metasystem.it/>

## **Netherlands**

Hierbij verklaar ik, Meta System S.p.A., dat het type radioapparatuur TXBMWMMR conform is met Richtlijn 2014/53/EU.

De volledige tekst van de EU-conformiteitsverklaring kan worden geraadpleegd op het volgende internetadres: <https://docs.metasystem.it/>

## **Poland**

Meta System S.p.A. niniejszym oświadcza, że typ urządzenia radiowego TXBMWMMR jest zgodny z dyrektywą 2014/53/UE. Pełny tekst deklaracji zgodności UE jest dostępny pod następującym adresem internetowym: <https://docs.metasystem.it/>

## **Portugal**

O(a) abaixo assinado(a) Meta System S.p.A. declara que o presente tipo de equipamento de rádio TXBMWMMR está em conformidade com a Diretiva 2014/53/UE.

O texto integral da declaração de conformidade está disponível no seguinte endereço de Internet: <https://docs.metasystem.it/>

## **Romania**

Prin prezenta, Meta System S.p.A. declară că tipul de echipamente radio TXBMWMR este în conformitate cu Directiva 2014/53/UE. Textul integral al declarației UE de conformitate este disponibil la următoarea adresă internet: <https://docs.metasystem.it/>

## **Sweden**

Härmed försäkras Meta System S.p.A. att denna typ av radioutrustning TXBMWMR överensstämmer med direktiv 2014/53/EU. Den fullständiga texten till EU-försäkran om överensstämmelse finns på följande webbadress: <https://docs.metasystem.it/>

## **Slovenia**

Meta System S.p.A. potrjuje, da je tip radijske opreme TXBMWMR skladen z Direktivo 2014/53/EU. Celotno besedilo izjave EU o skladnosti je na voljo na naslednjem spletnem naslovu: <https://docs.metasystem.it/>

## **Slovakia**

Meta System S.p.A. týmto vyhlasuje, že rádiové zariadenie typu TXBMWMR je v súlade so smernicou 2014/53/EÚ. Úplné EÚ vyhlásenie o zhode je k dispozícii na tejto internetovej adrese: <https://docs.metasystem.it/>

# 200 INDEX

- A**
  - Abbreviations and symbols, 4
  - ABS
    - Indicator and warning light, 32
    - Self-diagnosis, 84
    - Technology in detail, 98
  - Accessories
    - General notes, 138
  - Adaptive front lighting, 106
    - Technology in detail, 106
  - Ambient temperature
    - Outside temperature warning, 32
  - Anti-theft alarm system
    - Activating, 54
    - Adjusting, 55
    - Deactivating, 55
    - Indicator light, 19, 20
    - Operation, 54
    - Warning indicator, 34
  - ASC
    - Indicator and warning light, 33
    - Operation, 56
    - Self-diagnosis, 85
    - Switching off, 56
    - Switching on, 56
    - Technology in detail, 101
  - Average fuel consumption
    - Display: CONS, 48
  - Average speed
    - Display: SPEED, 48
  - Average values
    - Resetting, 49
- B**
  - Battery
    - Charging a disconnected battery, 133
    - Maintenance instructions, 131
    - Position on the vehicle, 16
    - Recharging connected battery, 132
    - Replacing the battery, 133
    - Technical data, 166
    - Vehicle voltage too low, 31
  - Brake fluid
    - Checking the front fluid level, 116
    - Checking the rear fluid level, 117
    - Front expansion tank, 15
    - Rear expansion tank, 15
  - Brake pads
    - Break-in, 87
    - Checking the front, 114
    - Checking the rear, 115
  - Brakes
    - ABS Pro, 100
    - ABS Pro dependent on riding mode, 89
    - Adjusting the brake lever, 67
    - Checking function, 114
    - Checking operation, 114
    - Dynamic Brake Control dependent on riding mode, 89
    - Safety instructions, 87
    - Technical data, 164
    - Wear indicator, 116
  - Break-in, 86

**C**

## Care

- Chrome, 152
- Paint preservation, 153

## Chassis

- Technical data, 163

## Checklist, 82

## Clock

- Display: CLOCK, 46
- Setting the clock, 50

## Clutch

- Adjusting the clutch lever, 66
- Checking operation, 118
- Fluid reservoir, 14
- Technical data, 162

## Coolant temperature

- Display: ENGTMP, 46

## Current fuel consumption

- Display: CONS C, 48

**D**

## Damping

- Adjusting, 70

## Date

- Display: DATE, 48
- Setting the date, 51

## Diagnostic socket

- Fastening, 135
- Loosening, 135

## Dimensions

- Technical data, 166

## Display

- Adjusting the display brightness, 50

## Distance recorder

- Resetting, 49

## DTC

- Self-diagnosis, 86
- Switching on, 56
- Technology in detail, 101

## Dynamic Brake Control, 101

- Technology in detail, 101

## Dynamic engine brake control, 105

**E**

## Electrical system

- Technical data, 165

## Emergency-off switch, 18

- Operation, 42

## Engine, 31

- Indicator light for engine electronics, 30
- Severe fault, 30
- Starting, 83
- Technical data, 161

## Engine oil

- Checking fill level, 112
- Fill level indicator, 14
- Oil filler opening, 15
- Technical data, 160
- Topping up, 113

## Equipment, 5

**F**

## Frame

- Technical data, 162

## Front wheel stand

- Mounting, 111

## Fuel

- Filler neck, 14
- Fuel reserve, 34
- Refueling procedure, 91
- Technical data, 160

## Fuel reserve

- Display of distance covered: TRIP R, 46
- Indicator lamp, 35

# 202 INDEX

## Fuses

- Fuse assignment, 134
- Replacing, 133
- Technical data, 165

## H

- Hazard warning flasher
  - Operating element, 17
  - Operation, 44

## Headlight

- Adjusting the headlight beam throw, 65
- Headlight beam throw, 65
- Setting for right-hand/left-hand traffic, 65

- Headlight courtesy delay feature, 43

## Headlight range

- Adjusting, 65

## Heated grips

- Operation, 60

## Horn, 17

## Hump cover, 145, 146

## I

### Ignition

- Switching off, 41
- Switching on, 40

### Immobilizer

- Spare key, 41
- Warning indicator, 30

### Indicator lights, 19, 20, 31

- ABS, 32
- Alarm system, 34
- ASC/DTC, 33
- Electronic engine management, 30
- Electronic immobilizer, 30
- Engine warning, 30
- Fuel reserve, 35

### Layout, 27

- Light source defective, 32
  - Outside temperature warning, 32
  - Overview, 24, 25
  - Vehicle voltage too low, 31
- ### Instrument cluster
- Ambient light sensor, 19, 20
  - Overview, 19, 20
  - Setting units, 52

## J

### Jump-starting, 130

## K

### Keys, 40

## L

### Light sources

- Indicator light for defective light source, 32
- Replacing the LED light source, 129
- Technical data, 166

### Lights

- Headlight courtesy delay feature, 43
- Low beams, 42
- Operating element, 17
- Operating headlight flasher, 43
- Operating high beams, 43
- Operating the parking lights, 43
- Parking lights, 43

### Luggage

- Lashing down, 139



**M**

- Maintenance
  - Maintenance schedule, 174
- Maintenance confirmations, 175
- Maintenance intervals, 172
- Mirrors
  - Adjusting, 64
- Mobility Services, 172
- Motorcycle
  - Care, 148
  - Cleaning, 148
  - Lashing down, 92
  - Parking, 89
  - Putting into operation, 153
  - Storage, 153
- Multifunction display, 19, 20
  - Exiting SETUP, 53
  - Overview, 26
  - Selecting the display, 46
  - SETUP, 50
- Multifunction switch
  - Overview, left, 17
  - Overview, right, 18

**N**

- Notice concerning current status, 6

**O**

- Odometer
  - Display: MI, 46
- Onboard vehicle toolkit
  - Position on the vehicle, 16
- Overview of warning indicators, 28
- Overviews
  - Indicator and warning lights, 24, 25
  - Instrument cluster, 19, 20
  - Left side of vehicle, 14

- Left-side multifunction switch, 17
- Multifunction displays, 26
- Right handlebar fitting, 18
- Right side of vehicle, 15
- Underneath the seat, 16

**P**

- Passenger frame
  - Installing, 143
  - Removing, 140
- Passenger seat
  - Installing, 61
  - Lock, 15
  - Removing, 61
- Payload table
  - Sign, 16
- Performance data
  - Technical data, 167
- Pre-Ride-Check, 83

**R**

- Rear-wheel drive
  - Technical data, 162
- Rear-wheel stand
  - Mounting, 112
- Refueling, 91
- Rider's seat
  - Installing, 61
  - Removing, 61
- Riding mode, 57
  - Technology in detail, 103
- Riding time
  - Display: RDTIME, 48

**S**

- Safety information
  - On braking, 87
  - on riding, 80
- Screw connections, 157

## 204 INDEX

- Service, 171
    - Electronic service history, 171
    - Reporting safety defects, 170
  - Service display, 36
  - Settings
    - Display: SETUP ENTER, 46
  - SETUP
    - Exiting, 53
    - Resetting, 53
    - Selecting, 50
  - Spark plugs
    - Technical data, 166
  - Speed control
    - Operation, 58
  - Speedometer, 19, 20, 26
  - Spring preload
    - Adjusting, 68
    - Rear adjusting element, 15
  - Start, 83
    - Operating element, 18
  - Steering lock, 40
  - Switching off, 89
- T**
- Tachometer, 19, 20
  - Technical data
    - Battery, 166
    - Brakes, 164
    - Chassis, 163
    - Clutch, 162
    - Dimensions, 166
    - Electrical system, 165
    - Engine, 161
    - Engine oil, 160
    - Frame, 162
    - Fuel, 160
    - Fuses, 165
    - General notes, 5
    - Light sources, 166
    - Performance data, 167
    - Rear-wheel drive, 162
    - Spark plugs, 166
    - Standards, 5
    - Transmission, 162
    - Weights, 167
    - Wheels and tires, 164
- Tires**
- Checking tire pressure, 118
  - Checking tire tread depth, 119
  - Checking tread depth, 118
  - Running in, 87
  - Technical data, 164
  - Tire pressures, 165
- Torques, 157**
- Traction Control**
- ASC, 101
  - DTC, 101
- Transmission**
- Technical data, 162
- Trip recorder**
- Display: MI 1 or MI A, 46
- Troubleshooting chart, 156**
- Turn signals**
- Operating element, 17
  - Operation, 44
- Type plate**
- Position on the vehicle, 14
- U**
- USB charging interface
    - Position on the vehicle, 14
- V**
- Vehicle identification number
    - Position on the vehicle, 15
  - Vehicle voltage
    - Display: VOLTGE, 48
- W**
- Warning lights, 19, 20

## Weights

Technical data, 167

## Wheels

Checking spokes, 120

Checking wheel rims, 120

Installing the front wheel, 123

Installing the rear wheel, 127

Removing the front

wheel, 120

Removing the rear wheel, 126

Size change, 120

Technical data, 164

The descriptions and illustrations in this manual may vary from your own motorcycle's actual equipment, depending upon its equipment level and accessories as well as your specific national version. No claims will be entertained as a result of such discrepancies. Dimensions, weights, fuel consumption and performance data are quoted to the customary tolerances. The right to modify designs, equipment and accessories is reserved. Errors and omissions excepted.

© 2020 Bayerische Motoren Werke Aktiengesellschaft  
80788 Munich, Germany  
Reprinting, in whole or in part, is only permitted with the written permission of BMW Motorrad, Aftersales. Original Rider's Manual, printed in Germany.



## **WARNING**

### **Harmful substances**

Operating, servicing and maintaining a passenger vehicle or off-road vehicle can expose you to chemicals including engine exhaust, carbon monoxide, phthalates and lead, which are known to the State of California to be carcinogenic or detrimental to childbirth or reproduction.

- To minimize exposure, avoid breathing exhaust, do not idle the engine except as necessary, service your vehicle in a well-ventilated area and wear gloves or wash your hands frequently when servicing your vehicle.
- For more information visit: [www.P65Warnings.ca.gov/passenger-vehicle](http://www.P65Warnings.ca.gov/passenger-vehicle)

## Important data for refueling:

---

### Fuel

---

Recommended fuel quality	Super unleaded (max. 15% ethanol, E15) 89 AKI (95 ROZ/RON) 90 AKI
--------------------------	---

---

Alternative fuel quality	Regular unleaded (max. 15% ethanol, E15) 87 AKI (91 ROZ/RON) 87 AKI
--------------------------	---

---

Usable fuel quantity	Approx. 4.8 gal (Approx. 18 l)
----------------------	--------------------------------

---

Reserve fuel quantity	Approx. 3.7 quarts (Approx. 3.5 l)
-----------------------	------------------------------------

---

### Tire pressures

---

Front tire pressure	36.3 psi (2.5 bar), with tire cold
---------------------	------------------------------------

---

Rear tire pressure	39.2 psi (2.7 bar), One-up, with cold tires 42.1 psi (2.9 bar), Two-up and cargo, with cold tires
--------------------	--

---

You can find further information on all aspects of your vehicle at: [bmw-motorrad.com](http://bmw-motorrad.com)

**BMW recommends** **ADVANTEC**  
ORIGINAL BMW ENGINE OIL

Order No.: 01 40 9 830 257  
06-2020, 1st edition, 07

