



BMW Motorrad



Rider's Manual
R 1200 GS

Vehicle data/dealership details

Vehicle data

Model

Vehicle Identification Number

Colour code

Date of first registration

Registration number

Dealership details

Person to contact in Service department

Ms/Mr

Phone number

Dealership address/phone number (company stamp)

Welcome to BMW

We congratulate you on your choice of a vehicle from BMW Motorrad and welcome you to the community of BMW riders. Familiarise yourself with your new vehicle so that you can ride it safely and confidently in all traffic situations.

About this Rider's Manual

Please read this Rider's Manual carefully before starting to use your new BMW. It contains important information on how to operate the controls and how to make the best possible use of all your BMW's technical features. In addition, it contains information on maintenance and care to help you maintain your vehicle's reliability and safety, as well as its value.

This record of the maintenance work you have had performed on

your vehicle is a precondition for generous treatment of goodwill claims.

If the time comes to sell your BMW, please remember to hand over this Rider's Manual to the new owner. It is an important part of the vehicle.

Suggestions and criticism

If you have questions concerning your vehicle, your authorised BMW Motorrad dealer will gladly provide advice and assistance.

We hope you will enjoy riding your BMW and that all your journeys will be pleasant and safe

BMW Motorrad.

01 40 8 406 501



Table of Contents

1 General instructions 5	Warnings 25	PRO riding mode 80
Overview 6	4 Operation..... 55	Cruise-control system 82
Abbreviations and symbols 6	Ignition switch/steering lock 56	Hill Start Control 85
Equipment 7	Ignition with Key- less Ride 58	Anti-theft alarm (DWA) 86
Technical data 7	Emergency off switch (kill switch) 62	Tyre pressure monitoring (RDC) 89
Actuality 7	Intelligent emergency call 62	Heated handlebar grips 89
2 General views 9	Lights 65	On-board computer 90
General view, left side 11	Day run lights 67	Front and rear seats..... 91
General view, right side 13	Hazard warning lights sys- tem 69	5 TFT display 95
Underneath the seat 14	Turn indicators 69	General instructions 96
Multifunction switch, left 15	Anti-lock brake system (ABS)..... 70	Principle..... 97
Multifunction switch, right 17	Automatic Stability Control (ASC) 71	Pure Ride view 103
Instrument panel 18	Dynamic Traction Control (DTC) 73	General settings..... 105
3 Status indicators 19	Electronic Suspension Ad- justment (D-ESA) 75	Bluetooth..... 106
Indicator and warning lights 20	Riding mode 78	My Vehicle 110
TFT display in Pure Ride view 22		Navigation 113
TFT display in the View menu..... 24		Media 115
		Phone 115
		Switch GPS synchronisa- tion on or off 116
		Display software version 116

Display licence information	116	Securing motorcycle for transportation	142	Coolant.....	168
6 Adjustment.....	117	8 Engineering details	145	Tyres.....	170
Mirrors	118	General instructions	146	Wheel rims and tyres.....	170
Headlight.....	118	Anti-lock brake system (ABS).....	146	Wheels	171
Windscreen	119	Automatic Stability Control (ASC)	149	Air filter.....	177
Clutch.....	120	Dynamic Traction Control (DTC)	150	Light source.....	179
Brakes	120	Dynamic ESA	152	Jump-starting	184
Handlebars	121	Riding mode	152	Battery	185
Spring preload	121	Tyre pressure monitoring (RDC)	155	Fuses	189
Damping	122	Shift assistant	156	Diagnostic connector.....	191
7 Riding.....	125	Hill Start Control	157	10 Accessories	193
Safety instructions	126	9 Maintenance	159	General instructions	194
Comply with checklist.....	129	General instructions	160	Power sockets	194
Always before riding off ...	129	Toolkit.....	160	Cases	195
Every 3rd refuelling stop	129	Service toolkit	160	Topcase.....	198
Starting.....	129	Front-wheel stand.....	161	Navigation system.....	204
Running in	133	Engine oil	162	11 Care	211
Off-roading.....	133	Brake system	163	Care products	212
Shifting gear	135	Clutch.....	168	Washing the vehicle.....	212
Brakes	136			Cleaning easily damaged components.....	213
Parking your motorcycle	138			Paint care	214
Refuelling	138			Protective wax coating ...	214
				Laying up the motorcycle	214

Restoring motorcycle to use	214
12 Technical data	215
Troubleshooting chart	216
Screw connections	218
Fuel	220
Engine oil	221
Engine	221
Clutch	222
Transmission	222
Rear-wheel drive	223
Frame	224
Chassis and suspension	224
Brakes	226
Wheels and tyres	227
Electrical system	228
Anti-theft alarm	230
Dimensions	230
Weights	233
Riding specifications	233

13 Service	235
BMW Motorrad Service ...	236
BMW Motorrad Mobility services	236
Maintenance work	236
BMW Service	237
Maintenance schedule	239
Maintenance confirmations	240
Service confirmations	254
14 Appendix	257
Certificate for Electronic Immobiliser	258
Certificate for Keyless Ride	260
Certificate for Tyre Pressure Control (RDC)	262
Certificate for TFT instrument cluster	263
15 Index	266

General instructions

Overview	6
Abbreviations and symbols	6
Equipment	7
Technical data	7
Actuality	7

Overview

An important aspect of this Rider's Manual is that it can be used for quick and easy reference. Consulting the extensive index at the end of this Rider's Manual is the fastest way to find information on a particular topic or item. To first read an overview of your motorcycle, please go to Chapter 2. All maintenance and repair work on the motorcycle is documented in Chapter 12. This record of the maintenance work you have had performed on your vehicle is a precondition for generous treatment of goodwill claims. When the time comes to sell your BMW, please remember to hand over this Rider's Manual; it is an important part of the motorcycle.

Abbreviations and symbols



CAUTION Low-risk hazard. Non-avoidance can lead to slight or moderate injury.



WARNING Medium-risk hazard. Non-avoidance can lead to fatal or severe injury.



DANGER High-risk hazard. Non-avoidance leads to fatal or severe injury.





ATTENTION Special notes and precautionary measures. Non-compliance can lead to damage to the vehicle or accessory and, consequently, to voiding of the warranty.



NOTICE Specific instructions on how to operate, control, adjust or look after items of equipment on the vehicle.



Indicates the end of an item of information.

- Instruction.
- » Result of an activity.
- ➔ Reference to a page with more detailed information.
- ◁ Indicates the end of a passage relating to specific accessories or items of equipment.
-  Tightening torque.
-  Technical data.
- NV National-market version.

OE Optional extras.
The vehicles are assembled complete with all the BMW Motorrad optional extras originally ordered.

OA Optional accessories.
You can obtain BMW Motorrad optional accessories through your authorised BMW Motorrad dealer; optional accessories have to be retrofitted to the vehicle.

ABS Anti-lock brake system.

ASC Automatic Stability Control.

D-ESA Electronic chassis and suspension adjustment.

DTC Dynamic Traction Control (optional extra only in combination with Pro riding modes).

DWA Anti-theft alarm (Diebstahlwarnanlage).

EWS Electronic immobiliser.

RDC Tyre pressure monitoring.

Equipment

When you purchased your BMW motorcycle, you chose a model with individual equipment. This Rider's Manual describes the optional extras (OE) offered by BMW and selected optional accessories (OA). This explains why the manual may also contain equipment specifications which you have not ordered. Please note, too, that your motorcycle might not be exactly as illus-

trated in this manual on account of country-specific differences. If your motorcycle contains equipment that has not been described, its description can be found in a separate manual.

Technical data

All dimensions, weights and power ratings stated in the Rider's Manual are quoted to the standards and comply with the tolerance requirements of the Deutsches Institut für Normung e.V. (DIN). Versions for individual countries may differ.

Actuality

The high safety and quality level of BMW motorcycles is ensured by continuous development work on design, equipment and accessories. Because of this, your motorcycle may differ from the information supplied in the Rider's Manual. Nor

can BMW Motorrad entirely rule out errors and omissions. Consequently no claims can be derived from the information, graphics or descriptions.

General views

General view, left side.....	11
General view, right side	13
Underneath the seat	14
Multifunction switch, left	15
Multifunction switch, right.....	17
Instrument panel	18



General view, left side

- 1 Fuel filler neck (▣▣▣▣▶ 139)
- 2 Seat lock (▣▣▣▣▶ 91)
- 3 Setting the rear damping
(down at the spring strut)
(▣▣▣▣▶ 122)

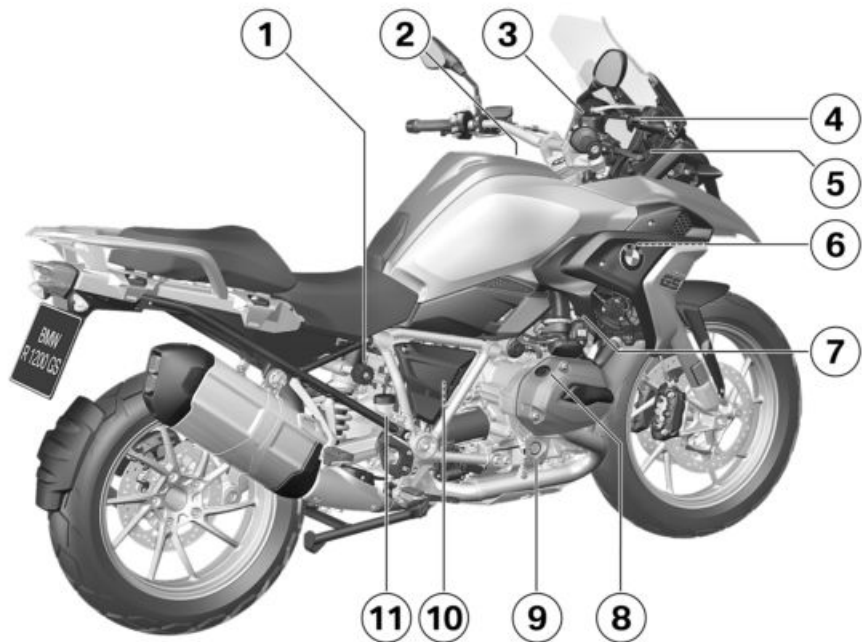

General view, right side

- 1 Adjuster for spring preload, rear (➡ 121)
- 2 Air filter (underneath the centre trim panel) (➡ 177)
- 3 Brake-fluid tank, front (➡ 166)
- 4 Height adjustment of the windscreen (➡ 119)
- 5 Power socket (➡ 194)
- 6 Vehicle identification number (on the steering-head bearing)
Type plate (on the steering-head bearing)
- 7 Coolant-level indicator (➡ 168)
Coolant reservoir (➡ 169)
- 8 Oil filler neck (➡ 163)
- 9 Engine oil level indicator (➡ 162)
- 10 Behind the side trim panel:
Battery (➡ 185)
Positive battery connection point (➡ 184)
Diagnostic connector (➡ 191)
- 11 Brake-fluid reservoir, rear (➡ 167)

Underneath the seat

- 1 Standard toolkit (► 160)
- 2 Rider's Manual
- 3 Tyre pressure table
- 4 Payload table
- 5 Adjusting the front seat height (► 92)
- 6 Fuses (► 189)

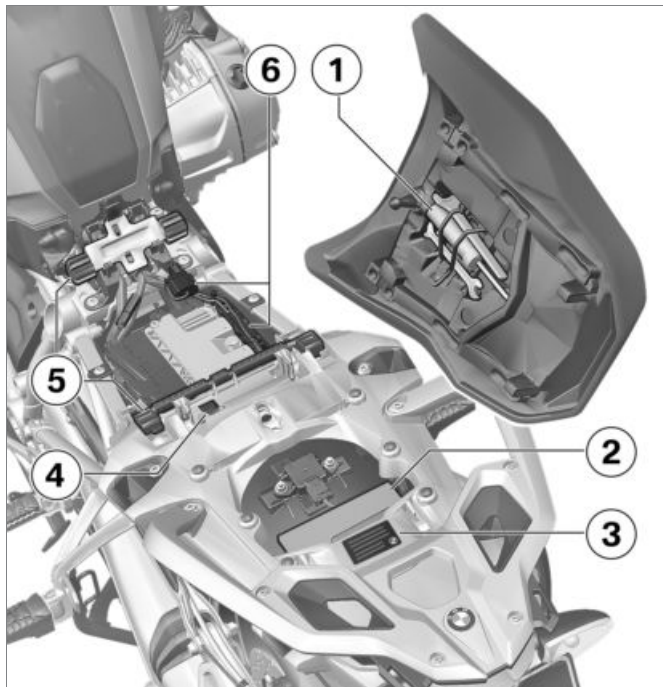

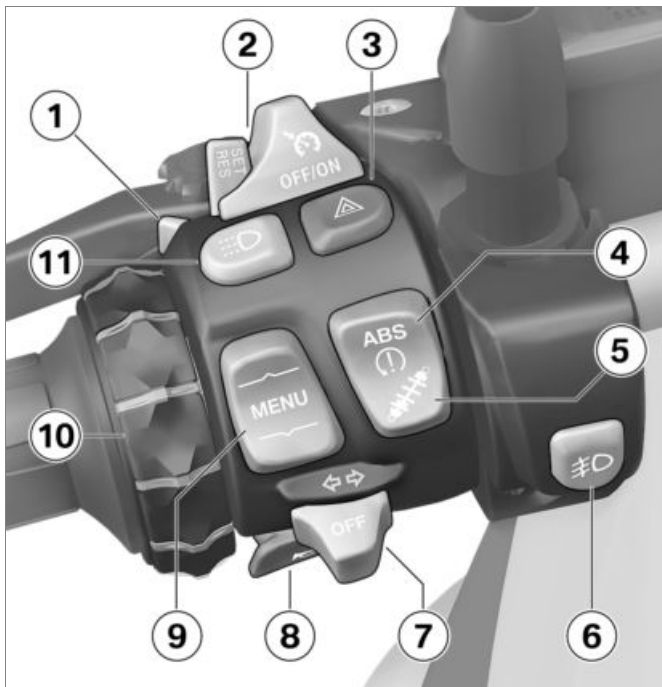

Multifunction switch, left

- 1 High-beam headlight and headlight flasher (➡ 65)
- 2 – with cruise control^{OE}
Cruise-control system (➡ 83).
- 3 Hazard warning lights system (➡ 69)
- 4 ABS (➡ 70)
ASC (➡ 71)
– with riding modes Pro^{OE}
DTC (➡ 73)
- 5 – with Dynamic ESA^{OE}
Dynamic ESA possible settings (➡ 75)
- 6 – with LED auxiliary headlights^{OA}
Auxiliary headlights (➡ 66).
- 7 Turn indicators (➡ 69)
- 8 Horn
- 9 MENU/ rocker switch (➡ 97)

- 10 Multi-Controller Controls (→ 97)
- 11 – with daytime riding light^{OE}
Manual daytime riding light (→ 67).

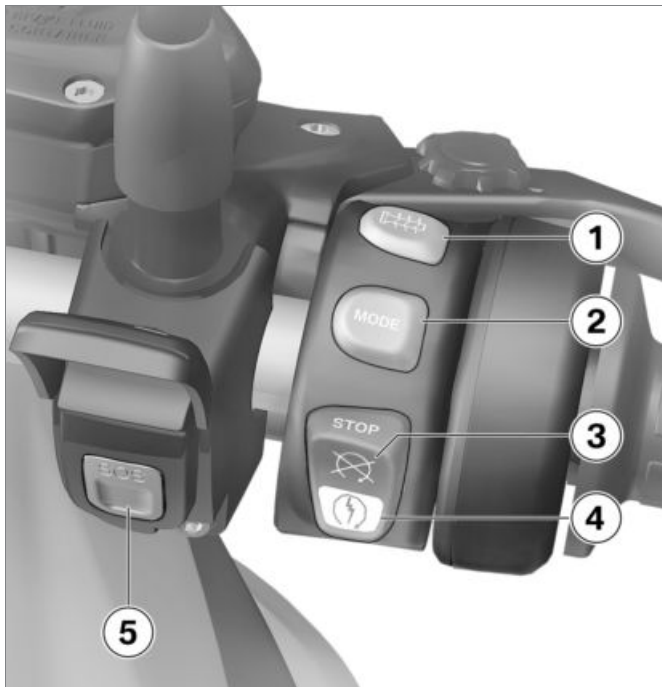

Multifunction switch, right

- 1 – with heated grips^{OE}
Heated handlebar grips (➔ 89).
- 2 Riding mode (➔ 78)
- 3 Emergency off switch (kill switch) (➔ 62)
- 4 Starter button
Starting the engine (➔ 129).
- 5 SOS button
Intelligent emergency call (➔ 63)

Instrument panel

- 1 Indicator and warning lights (➡ 20)
- 2 TFT display (➡ 22)
(➡ 24)
- 3 Alarm system LED
– with alarm system
(DWA)^{OE}
Alarm signal (➡ 87)
– with Keyless Ride^{OE}
Telltale light for the radio-
operated key
Ignition with Keyless Ride
(➡ 59).
- 4 Photosensor (for adapting
the brightness of the in-
strument lighting)

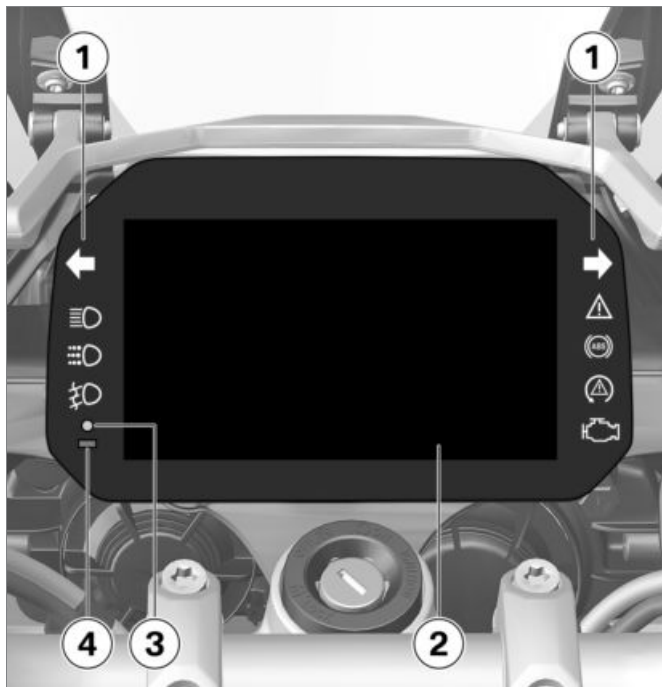



Status indicators

Indicator and warning lights	20
TFT display in Pure Ride view	22
TFT display in the View menu	24
Warnings	25

Indicator and warning lights

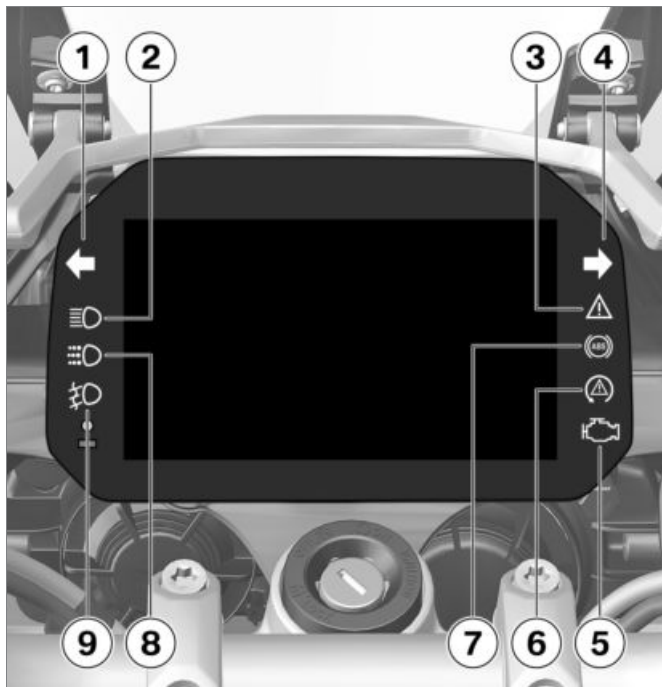
- 1 Turn indicators, left
Operating the turn indicators (►► 69).
- 2 High-beam headlight
(►► 65)
- 3 General warning light
(►► 25)
- 4 Turn indicators, right
- 5 - with export to EU markets^{NV}
Malfunction indicator lamp
Emissions warning (►► 41)
- 6 ASC (►► 48)
- with riding modes Pro^{OE}
DTC (►► 49)
- 7 ABS (►► 70)
- 8 - with daytime riding light^{OE}
Manual daytime riding light
(►► 67).



- 9** – with LED auxiliary headlights^{OA}
Auxiliary headlights
( 66).

TFT display in Pure Ride view

- 1 Hill Start Control (➡ 51)
- 2 Change of operating focus (➡ 101)
- 3 Engine speed display (➡ 103)
- 4 Rider info status line (➡ 102)
- 5 Speedometer
- 6 Coding plug (➡ 81)
- 7 Riding mode (➡ 78)
- 8 Recommendation to up-shift (➡ 104)
- 9 Gear indicator; "N" indicates neutral.
- 10 Speed Limit Info (➡ 103)
– with cruise control^{OE}
- 11 Cruise-control system (➡ 83).
- 12 Time (➡ 105)
- 13 Connection status (➡ 107)
- 14 Muting (➡ 105)

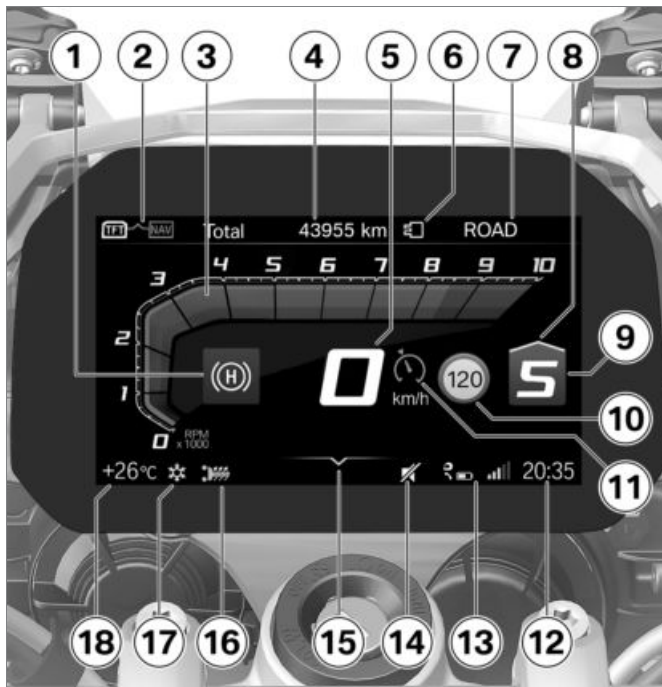

- 15** Operating help
- 16** Heating stages, handlebar grips (➡ 89)
- 17** Outside temperature warning (➡ 36)
- 18** Ambient temperature

TFT display in the View menu

- 1 Hill Start Control (➡ 51)
- 2 Speedometer
- 3 – with cruise control^{OE}
Cruise-control system (➡ 83).
- 4 Speed Limit Info (➡ 103)
- 5 Coding plug (➡ 81)
- 6 Riding mode (➡ 78)
- 7 Rider info status line (➡ 102)
- 8 Recommendation to up-shift (➡ 104)
- 9 Gear indicator; "N" indicates neutral.
- 10 Time
- 11 Connection status
- 12 Muting (➡ 105)
- 13 Operating help
- 14 Menu area
- 15 Heating stages, handlebar grips (➡ 89)

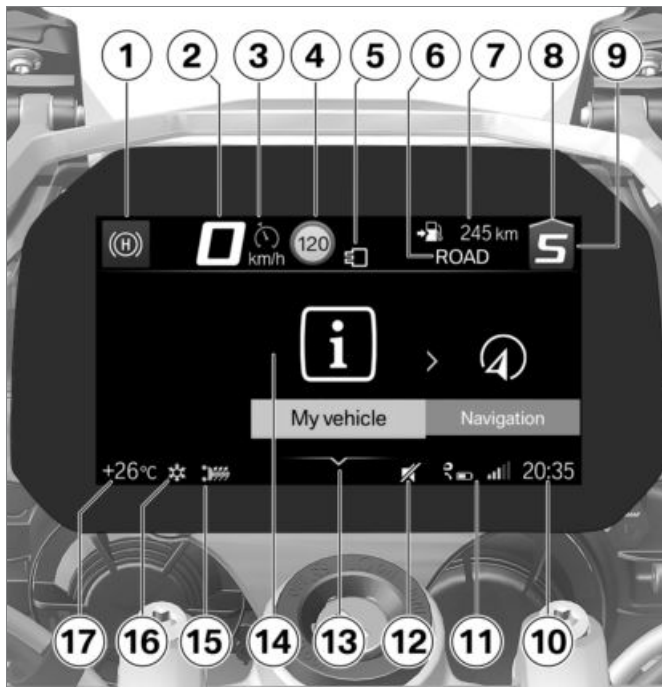

- 16 Outside temperature warning (→ 36)
- 17 Ambient temperature

Warnings

Mode of presentation

Warnings are indicated by the corresponding warning lights. Warnings are displayed by the general warning lights in conjunction with a dialogue box on the TFT display. The 'general' warning light shows yellow or red, depending on the urgency of the warning.



The status of the 'General' warning light matches the most urgent warning. The possible warnings are listed on the next pages.



Check control display

The messages on the display are shown in different ways. Different colours and symbols are used depending on priority:

- Green CHECK OK **1**: no message, optimum value.
- White circle with small "i" **2**: information.
- Yellow warning triangle **3**: warning message, value not ideal.
- Red warning triangle **3**: warning message, critical value

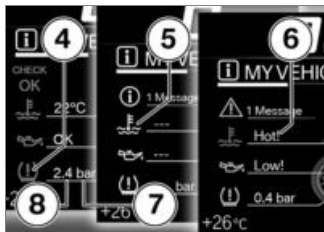

Value display

The symbols **4** are shown in different ways. Depending on the evaluation, different colours are used. Instead of numerical values **8** with units **7**, text **6** is always used on the display:

Colour of the symbol

- Green: (OK) Current value is ideal.
- Blue: (Cold!) Current temperature is too low.
- Yellow: (Low! /High!) Current value is too low or too high.

- Red: (Hot! /High!) Current temperature or value is too high.
- White: (---) There is no valid value. Dashes **5** are displayed instead of the value.



NOTICE

The assessment of some values is only possible from a certain journey duration or speed. If a measured value is still not being displayed because the conditions for measurement have not been met, dashes are displayed instead as a placeholder. If there are no valid measured values, there will be no assessment in the form of a coloured symbol. ◀



Check control dialogue box

Messages are given in the form of a check control dialogue box **1**.

- If there are multiple check control messages of equal priority, the messages alternate in the order in which they occurred until they are acknowledged.
- If symbol **2** is actively displayed, it can be acknowledged by tilting the multi-controller to the left.
- Check Control messages are attached dynamically to the pages in the Vehicle menu as additional tabs (▣▣▣ 99). As













long as the problem persists,
the message can be called up
again.

Warnings, overview

Indicator and warning lights

Display text















Meaning

		Ice crystal symbol is displayed.	Outside temperature warning (►►► 36)
		Remote key not in range.	Radio-operated key out of range (►►► 36)
		Remote key battery at 50%.	Replace the battery of the radio-operated key (►►► 37)
		Remote key battery weak.	
		is displayed in yellow.	Vehicle voltage too low (►►► 37)
		Vehicle voltage low.	
		is displayed in red.	Vehicle voltage critical (►►► 38)
		Vehicle voltage critical!	

Indicator and warning lights

Display text













Meaning











 General warning light shows yellow.	 The faulty bulb is displayed.	Bulb faulty (→ 38)
	 Alarm system batt. capacity weak.	Anti-theft alarm battery weak (→ 39)
 General warning light shows yellow.	 Alarm system battery empty.	Anti-theft alarm battery flat (→ 40)
	 Oil level too low! Check oil level.	Engine-oil level too low (→ 40)
 General warning light shows red.	 Coolant temperature too high!	Coolant temperature too high (→ 40)
 The malfunction indicator lamp lights up.	 Exhaust re-treatment impaired.	Emissions warning (→ 41)
 General warning light shows yellow.	 No communication with engine control.	Engine control failed (→ 41)
 General warning light shows yellow.	 Fault in the engine control.	Engine in emergency-operation mode (→ 41)

Indicator and warning lights

Display text

Meaning











	General warning light flashes yellow.	 Serious fault in the engine control!	Severe fault in the engine control (▣▣▣➔ 42)
	General warning light shows yellow.	 is displayed in yellow.	Tyre pressure in limit range of the permitted tolerance (▣▣▣➔ 44)
		 Tyre pressure does not match setpoint	
	General warning light flashes red.	 is displayed in red.	Tyre pressure outside the permitted tolerance (▣▣▣➔ 44)
		 Tyre pressure does not match setpoint	
		 Tyre press. control. Loss of pressure.	
		 "----"	Transmission fault (▣▣▣➔ 45)
	General warning light shows yellow.	 "----"	Sensor faulty or system fault (▣▣▣➔ 46)

Indicator and warning lights	Display text	Meaning
 General warning light shows yellow.	 RDC sensor battery weak..	Battery for tyre pressure sensor weak (▣▣▣▣ 46)
	 Drop sensor faulty.	Drop sensor defective (▣▣▣▣ 46)
	 Emergency call failure.	Emergency call function restricted (▣▣▣▣ 46)
	 Side stand monitoring faulty.	Side stand monitoring is faulty (▣▣▣▣ 47)
 ABS telltale and warning light flashes.		ABS self-diagnosis not completed (▣▣▣▣ 47)
 ABS telltale and warning light shows.	 Off!	ABS deactivated (▣▣▣▣ 47)
	 ABS deactivated.	
 ABS telltale and warning light shows.	 Limited ABS availability!	ABS fault (▣▣▣▣ 47)

Indicator and warning lights

Display text











Meaning

	ABS telltale and warning light shows.	 ABS failure!	ABS failed (→ 48)
	ABS telltale and warning light shows.	 ABS Pro failure!	ABS Pro failed (→ 48)
	ASC telltale and warning light quick-flashes.		ASC intervention (→ 48)
	ASC telltale and warning light slow-flashes.		ASC self-diagnosis not completed (→ 49)
	ASC telltale and warning light shows.	 Off!	ASC switched off (→ 49)
		 Traction control deactivated.	
	ASC telltale and warning light shows.	 Traction control failure!	ASC fault (→ 49)

Indicator and warning lights

Display text









Meaning

	DTC indicator and warning light flashes quickly.		DTC intervention (→ 49)
	DTC indicator and warning light flashes slowly.		DTC self-diagnosis not completed (→ 50)
	DTC indicator and warning light shows.	 Off!	DTC switched off (→ 50)
		 Traction control deactivated.	
	DTC indicator and warning light shows.	 Traction control failure!	DTC fault (→ 50)
	General warning light shows yellow.	 Spring strut adjustment faulty!	D-ESA fault (→ 51)
		 Fuel reserve reached. Go to a filling station soon	Fuel down to reserve (→ 51)

Indicator and warning lights

Display text

Meaning

		The holding symbol is displayed.	Hill Start Control activated (▶▶▶▶ 51)
		The holding symbol flashes briefly.	Hill Start Control is deactivated automatically (▶▶▶▶ 52)
		The holding symbol flashes briefly.	Hill Start Control cannot be activated (▶▶▶▶ 52)
		The gear indicator flashes.	Gear not trained (▶▶▶▶ 52)
		Turn signal indicator light flashes green.	Hazard warning lights system is switched on (▶▶▶▶ 53)
		Turn signal indicator light flashes green.	
		is displayed in white.	Service due (▶▶▶▶ 53)

Service due!

Indicator and warning lights

Display text

Meaning



General warning light shows yellow.



is displayed in yellow.

Service-due date has passed ( 53)

Service overdue!

Ambient temperature

The ambient temperature is displayed status line of the TFT display.

When the motorcycle is at a standstill, the heat of the engine can falsify the ambient-temperature reading. If the heat of the engine is affecting it too much, dashes are temporarily shown in place of the value.



If the ambient temperature falls below the following limit value, there is a risk of black ice.



Limit value for the ambient temperature

approx. 3 °C

Once the temperature has fallen below that value, the ambient temperature display along with a snowflake symbol flashes in the status line on the TFT display.

Outside temperature warning



Ice crystal symbol is displayed.

Possible cause:



The air temperature measured at the vehicle is lower than:

approx. 3 °C



WARNING

Risk of black ice also applicable at over 3 °C

Risk of accident

- Always take extra care when temperatures are low; remember that there is particular danger of black ice forming on bridges and where the road is in shade.◀
- Ride carefully and think well ahead.

Radio-operated key out of range

– with Keyless Ride^{OE}



General warning light shows yellow.



Remote key not in range. Do not stop engine. Not possible to restart the engine.

Possible cause:

Communication between R/C key and engine electronics is disrupted.

- Check the battery in the radio-operated key.
- with Keyless Ride^{OE}
- Replace the battery of the radio-operated key (▶▶▶ 61).
 - Use the reserve key to continue your journey.
- with Keyless Ride^{OE}
- Battery of the radio-operated key is flat or the key has been lost (▶▶▶ 60).

- If a check control dialogue box appears during the journey, remain calm. You can continue your journey; the engine will not switch off.
- Have the defective radio-operated key replaced by an authorised BMW Motorrad dealer.

Replace the battery of the radio-operated key

 General warning light shows yellow.

 Remote key battery at 50%. No functional impairment.

 Remote key battery weak. Limited central locking function. Change battery.

Possible cause:

- The integral battery in the radio-operated key has lost a significant proportion of its original capacity. There is no

assurance of how long the R/C key can remain operational.

– with Keyless Ride^{OE}

- Replace the battery of the radio-operated key (►► 61).

Vehicle voltage too low

 General warning light shows yellow.

 is displayed in yellow.

 Vehicle voltage low. Switch off unnecessary consumers.

WARNING

Discharged battery causes various motorcycle systems to fail, such as lighting, engine or ABS

Risk of accident

- Do not continue your journey.◀

The battery will not be charged. By continuing to drive on, the

vehicle electronics discharge the battery.

NOTICE

If the 12 V battery is not correctly installed or if the polarity of the terminals is reversed (e.g. in an attempt to jump-start the vehicle), this can cause the fuse for the alternator regulator to blow.◀

Possible cause:

The alternator or alternator drive is faulty, battery is faulty or the fuse for the alternator regulator has blown.

- Have the fault rectified as quickly as possible by a specialist workshop, preferably an authorised BMW Motorrad dealer.

Vehicle voltage critical



General warning light shows red.



is displayed in red.



Vehicle voltage critical! Consumers were switched off. Check battery condition.



WARNING

Discharged battery causes various motorcycle systems to fail, such as lighting, engine or ABS

Risk of accident

- Do not continue your journey.◀

The battery will not be charged. By continuing to drive on, the vehicle electronics discharge the battery.



NOTICE

If the 12 V battery is not correctly installed or if the polarity of the terminals is reversed (e.g. in an attempt to jump-start the vehicle), this can cause the fuse for the alternator regulator to blow.◀

Possible cause:

The alternator or alternator drive is faulty, battery is faulty or the fuse for the alternator regulator has blown.

- Have the fault rectified as quickly as possible by a specialist workshop, preferably an authorised BMW Motorrad dealer.

Bulb faulty



General warning light shows yellow.



The faulty bulb is displayed:



High beam faulty!



Front left turn indicator faulty! OR

Front right turn indicator faulty!



Low-beam headlight faulty!



Front side light faulty!

– with daytime riding light^{OE}



Daytime riding light faulty!◀

– with LED auxiliary headlights^{OA}



Left additional headlight faulty!

OR Right additional headlight faulty!◀



Tail light faulty!



Brake light faulty!



Rear left turn indicator faulty! Or
Rear right turn indicator faulty!



Number plate light faulty!

– Have it checked by a specialist workshop.



WARNING

Vehicle overlooked in traffic due to failure of the lights on the vehicle

Safety risk

- Replace defective bulbs as soon as possible; always carry a complete set of spare bulbs if possible.◀

Possible cause:

One or more bulbs defective.

- Identify defective bulb or bulbs by visual check.
- Replacing bulbs for low-beam and high-beam headlight (▶▶▶ 179).
- Replacing bulb for parking light (▶▶▶ 181).
– with LED headlight^{OE}
- Replace LED headlights (▶▶▶ 184).
- Replacing bulbs for front and rear turn indicators (▶▶▶ 182).
- Replace the LED rear light (▶▶▶ 183).
– with LED flashing turn indicators^{OE}
- Replace LED flashing turn indicators (▶▶▶ 183).

Anti-theft alarm battery weak

– with alarm system (DWA)^{OE}



Alarm system batt. capacity weak. No restrictions. Make an appointment at a specialist workshop.



NOTICE

This error message shows briefly only after the Pre-Ride-Check completes.◀

Possible cause:

The integral battery in the anti-theft alarm has lost a significant proportion of its original capacity. There is no assurance of how long the anti-theft alarm can remain operational if the vehicle's battery is disconnected.

- Seek the advice of a specialist workshop, preferably an authorised BMW Motorrad dealer.

Anti-theft alarm battery flat

– with alarm system (DWA)^{OE}



General warning light shows yellow.



Alarm system battery empty. No independent alarm. Make an appointment at a specialist workshop.



NOTICE

This error message shows briefly only after the Pre-Ride-Check completes. ◀

Possible cause:

The integral battery in the anti-theft alarm has lost its entire original capacity. There is no assurance that the anti-theft alarm will be operational if the vehicle's battery is disconnected.

- Seek the advice of a specialist workshop, preferably an authorised BMW Motorrad dealer.

Electronic oil-level check



The electronic oil-level check rates the oil level in the engine as OK or Low!

The preconditions for the oil level check are as follows:

- Engine at operating temperature.
- Engine idling for at least ten seconds.
- Side stand retracted.
- Motorcycle standing upright on a smooth, level surface.

The those preconditions are not met, the oil level cannot be measured. Dashes will be displayed in place of the information.

Engine-oil level too low



Oil level too low!
Check oil level.

Possible cause:

The electronic oil-level sensor has registered an excessively low oil level. The next time you stop for fuel:

- Checking engine oil level (➡ 162).

If the oil level is too low:

- Topping up the engine oil (➡ 163).

If the oil level is correct:

- Seek the advice of a specialist workshop, preferably an authorised BMW Motorrad dealer.

Coolant temperature too high



General warning light shows red.



Coolant temperature too high! Check coolant level. Continue riding in part. load to cool down.



ATTENTION

Riding with overheated engine

Engine damage

- Compliance with the information set out below is essential.◀

Possible cause:

The coolant level is too low.

- Check coolant level (▮▮▮▮▶ 168).
- If the coolant level is too low:
- Leave the engine to cool down.
 - Topping up coolant (▮▮▮▮▶ 169).
 - Have the cooling system checked by a specialist workshop, preferably by a BMW Motorrad partner.

Possible cause:

The coolant temperature is too high.

- If possible, ride in the part-load range to cool down the engine.
- If the coolant temperature is frequently too high:
- Have the fault rectified as quickly as possible by a specialist workshop, preferably an authorised BMW Motorrad dealer.

Emissions warning



The malfunction indicator lamp lights up.



Exhaust re-treatment impaired. Have it checked by a specialist workshop.

Possible cause:

The engine control unit has diagnosed a fault which affects the pollutant emissions.

- Have the fault rectified by a specialist workshop, preferably an authorised BMW Motorrad dealer.
- » You can continue riding; pollutant emissions are higher than the threshold values.

Engine control failed



General warning light shows yellow.



No communication with engine control. Multiple sys. affected. Ride carefully to the next specialist workshop.

Engine in emergency-operation mode



General warning light shows yellow.



Fault in the engine control. Onward journey possible. Ride care-

fully to next specialist workshop.



WARNING

Unusual ride characteristics when engine running in emergency-operation mode

Risk of accident

- Adapt your style of riding accordingly: avoid accelerating sharply and overtaking.◀

Possible cause:

The engine control unit has diagnosed a fault which impairs the engine performance or throttle response. The engine is in emergency-operation mode. In exceptional cases, the engine stops and refuses to start.

- Have the fault rectified as quickly as possible by a specialist workshop, preferably an authorised BMW Motorrad dealer.

» It is possible to continue riding, however the engine performance and engine speed range may be impaired and not function as normal.

Severe fault in the engine control



General warning light flashes yellow.



Serious fault in the engine control! Onward journey possible. Engine damage possible. Have checked by workshop.



WARNING

Engine damage when running in emergency-operation mode

Risk of accident

- Adapt your style of riding accordingly: ride slowly, avoid sharp accelerating and overtaking.

- If possible, have the vehicle brought in and the fault rectified by a specialist workshop, preferably an authorised BMW Motorrad dealer.◀

Possible cause:

The engine control unit has diagnosed a fault which may cause severe secondary faults. The engine is in emergency-operation mode.

- It is possible to continue to ride but not recommended.
- Avoid high load and rpm ranges if possible.
- Have the fault rectified as quickly as possible by a specialist workshop, preferably an authorised BMW Motorrad dealer.

Tyre pressure

– with tyre pressure control (RDC)^{OE}

In addition to the MY VEHICLE menu screen and Check Control messages, there is the TYRE PRESSURE screen to display the tyre pressures:



The values on the left refer to the front wheel and the values on the right to the rear wheel.

The difference between the actual and target tyre pressures is displayed.

Immediately after the ignition is switched on, only dashes are displayed. The transmission of the tyre pressure value begins only once the following minimum speeds have been exceeded:



RDC sensor is not active

min 30 km/h (The RDC sensor does not transmit its signal to the vehicle until a certain minimum speed has been reached.)



The tyre pressures are shown in the TFT display as temperature compensated and always refer to the following tyre air temperature:

20 °C



If the tyre symbol is also displayed in yellow or red, this is a warning. The pressure difference is highlighted with an exclamation mark in the same colour.



If the value in question is close to the limit of the permissible tolerance range, the reading is accompanied by the 'General' warning light showing yellow.



If the tyre pressure registered by the sensor is outside the permissible tolerance range, the 'General' warning light flashes red.

For more information on BMW Motorrad tyre pressure control, see the "Engineering details" section from page (➡ 155).

Tyre pressure in limit range of the permitted tolerance

– with tyre pressure control (RDC)^{OE}



General warning light shows yellow.



is displayed in yellow.



Tyre pressure does not match setpoint Check tyre pressure.

Possible cause:

Measured tyre pressure is close to the limit of permitted tolerance.

- Correct tyre pressure.
- Before adjusting the tyre pressure, observe the information on temperature compensation and pressure adaptation in the section entitled "Engineering details":

- » Temperature compensation (▮▮▮▮ 155)
- » Pressure adaptation (▮▮▮▮ 156)
- » Find the correct tyre pressures in the following places:
 - On the back cover of the Rider's Manual
 - Instrument cluster in the TYRE PRESSURE view
 - Sign under the seat

Tyre pressure outside the permitted tolerance

– with tyre pressure control (RDC)^{OE}



General warning light flashes red.



is displayed in red.



Tyre pressure does not match setpoint Stop immediately! Check tyre pressure.



Tyre press. control. Loss of pressure.

Stop immediately! Check tyre pressure.



WARNING

Tyre pressure outside permitted tolerance.

Impairment of the vehicle's handling characteristics.

- Adapt your style of riding accordingly. ◀

Possible cause:

Measured tyre pressure is outside permitted tolerance.

- Check the tyre for damage and to ascertain whether the vehicle can be ridden with the tyre in its present condition.

If the vehicle can be ridden with the tyre in its present condition:

- Correct the tyre pressure at the earliest possible opportunity.
- Before adjusting the tyre pressure, observe the information

on temperature compensation and pressure adaptation in the section entitled "Engineering details":

- » Temperature compensation (▣▣▣ 155)
- » Pressure adaptation (▣▣▣ 156)
- » Find the correct tyre pressures in the following places:
 - On the back cover of the Rider's Manual
 - Instrument cluster in the TYRE PRESSURE view
 - Sign under the seat
- Have the tyre checked for damage by a specialist workshop, preferably an authorised BMW Motorrad dealer.



NOTICE

You can deactivate RDC warnings for riding in off-road mode. ◀

If you are unsure whether the vehicle can be ridden with the tyre in its present condition:

- Do not continue your journey.
- Notify the breakdown service.

Transmission fault

– with tyre pressure control (RDC)^{OE}



"----"

Possible cause:

The vehicle has not reached the minimum speed (▣▣▣ 155).



RDC sensor is not active

min 30 km/h (The RDC sensor does not transmit its signal to the vehicle until a certain minimum speed has been reached.)

- Observe the RDC display at higher speeds.



A permanent fault is present only when the general warning light also lights up.

Under these circumstances:

- Have the fault rectified by a specialist workshop, preferably an authorised BMW Motorrad dealer.

Possible cause:

The radio link to the RDC sensors is faulty. Radio systems are located in the surrounding area which are interfering with the transmission between the RDC control unit and the sensors.

- Observe the RDC displays in other surrounding areas.



A permanent fault is present only when the general warning light also lights up.

Under these circumstances:

- Have the fault rectified by a specialist workshop, preferably an authorised BMW Motorrad dealer.

Sensor faulty or system fault

– with tyre pressure control (RDC)^{OE}

 General warning light shows yellow.

 "----"

Possible cause:

Vehicle is fitted with wheels not equipped with RDC sensors.

- Fit wheels and tyres equipped with RDC sensors.

Possible cause:

1 or 2 RDC sensors have failed or a system error has occurred.

- Have the fault rectified by a specialist workshop, preferably

an authorised BMW Motorrad dealer.

Battery for tyre pressure sensor weak

– with tyre pressure control (RDC)^{OE}

 General warning light shows yellow.

 RDC sensor battery weak. Function limited. Have it checked by a specialist workshop.



NOTICE

This error message shows briefly only after the Pre-Ride-Check completes. ◀

Possible cause:

The integral battery in the tyre-pressure sensor has lost a significant proportion of its original capacity. There is no assurance of how long the tyre pressure

control system can remain operational.

- Seek the advice of a specialist workshop, preferably an authorised BMW Motorrad dealer.

Drop sensor defective

 Drop sensor faulty. Have it checked by a specialist workshop.

Possible cause:

The drop sensor is not available.

- Seek the advice of a specialist workshop, preferably an authorised BMW Motorrad dealer.

Emergency call function restricted

– with intelligent emergency call^{OE}

 Emergency call failure. Make an appointment at a specialist workshop.

Possible cause:

The emergency call cannot be made automatically or via BMW.

- Observe information on operating the intelligent emergency call from page (▶▶▶ 63).
- Seek the advice of a specialist workshop, preferably an authorised BMW Motorrad dealer.

Side stand monitoring is faulty



Side stand monitoring faulty. To avoid breakdown do not stop engine. Have checked by spec. workshop.

Possible cause:

The side-stand switch or its wiring are damaged.

- Seek the advice of a specialist workshop, preferably an authorised BMW Motorrad dealer.

ABS self-diagnosis not completed



ABS telltale and warning light flashes.

Possible cause:



ABS self-diagnosis not completed

The ABS function is not available, because self-diagnosis did not complete. (The motorcycle has to reach a defined minimum speed for the wheel speed sensors to be checked: 5 km/h)

- Pull away slowly. Bear in mind that the ABS function is not available until self-diagnosis has completed.

ABS deactivated



ABS telltale and warning light shows.



Off!



ABS deactivated.

Possible cause:

The rider has switched off the ABS system.

- Activating the ABS function (▶▶▶ 71).

ABS fault



ABS telltale and warning light shows.



Limited ABS availability! Onward journey possible. Ride carefully to next specialist workshop.

Possible cause:

The ABS control unit has detected a fault. The partial integral brake has failed. The ABS function is restricted.

- You can continue to ride. Pay attention to the further information about certain situations that can lead to an ABS fault message (▣▣▣ 147).
- Have the fault rectified as quickly as possible by a specialist workshop, preferably an authorised BMW Motorrad dealer.

ABS failed



ABS telltale and warning light shows.



ABS failure! Onward journey possible.

Ride carefully to next specialist workshop.

Possible cause:

The ABS control unit has detected a fault. The ABS function is not available.

- You can continue to ride. Bear in mind the more detailed information on situations that can

lead to an ABS fault message (▣▣▣ 147).

- Have the fault rectified as quickly as possible by a specialist workshop, preferably an authorised BMW Motorrad dealer.

ABS Pro failed

– with riding modes Pro^{OE}



ABS telltale and warning light shows.



ABS Pro failure!

Onward journey possible. Ride carefully to next specialist workshop.

Possible cause:

The ABS Pro control unit has detected a fault. The ABS Pro function is not available. The ABS function is still available. ABS provides support only for braking in straight-ahead driving.

- You can continue to ride. Pay attention to the further information about certain situations that can lead to an ABS Pro fault message (▣▣▣ 147).
- Have the fault rectified as quickly as possible by a specialist workshop, preferably an authorised BMW Motorrad dealer.

ASC intervention

– without riding modes Pro^{OE}



ASC telltale and warning light quick-flashes.

The ASC has detected a degree of instability at the rear wheel and has intervened to reduce torque. The indicator and warning light flashes longer than the ASC intervention lasts. This affords the rider visual feedback on control intervention even after the critical situation has been dealt with.

ASC self-diagnosis not completed

– without riding modes Pro^{OE}

 ASC telltale and warning light slow-flashes.

Possible cause:

 ASC self-diagnosis not completed

The ASC function is not available, because self-diagnosis did not complete. (The motorcycle has to reach a defined minimum speed for the wheel sensors to be checked: min 5 km/h)

- Pull away slowly. The ASC indicator and warning light goes out after a few minutes.

The ASC indicator and warning light continues to flash:

- Seek the advice of a specialist workshop, preferably an authorised BMW Motorrad dealer.

ASC switched off

 ASC telltale and warning light shows.

 Off!

 Traction control deactivated.

Possible cause:

The rider has switched off the ASC system.

- without riding modes Pro^{OE}
- Activating the ASC function (➡ 72).

ASC fault

 ASC telltale and warning light shows.

 Traction control failure! Onward journey possible. Ride carefully to next specialist workshop.

Possible cause:

The DSC control unit has detected a fault. The ASC function is no longer available.

- You can continue to ride. Bear in mind that the ASC function is not available. Bear in mind the more detailed information on situations can lead to an ASC fault (➡ 150).
- Have the fault rectified as quickly as possible by a specialist workshop, preferably an authorised BMW Motorrad dealer.

DTC intervention

– with riding modes Pro^{OE}

 DTC indicator and warning light flashes quickly.

The DTC has detected a degree of instability at the rear wheel and has intervened to reduce torque. The indicator and warning light flashes longer than the

DTC intervention lasts. This affords the rider visual feedback on control intervention even after the critical situation has been dealt with.

DTC self-diagnosis not completed

– with riding modes Pro^{OE}

 DTC indicator and warning light flashes slowly.

Possible cause:



DTC self-diagnosis not completed

The DTC function is not available, because self-diagnosis did not complete. (The motorcycle has to reach a defined minimum speed with the engine running for the wheel-speed sensors to be checked: min 5 km/h)

- Pull away slowly. Bear in mind that the DTC function is not available until self-diagnosis has completed.

DTC switched off

– with riding modes Pro^{OE}

 DTC indicator and warning light shows.

 Off!

 Traction control deactivated.

Possible cause:

The rider has switched off the DTC system.

- DTC Switching on (➡ 74).

DTC fault

– with riding modes Pro^{OE}

 DTC indicator and warning light shows.



Traction control failure! Onward journey possible. Ride carefully to next specialist workshop.

Possible cause:

The DTC control unit has detected a fault.



ATTENTION

Damaged components

Damage to sensors, for example, which causes malfunctions

- Do not transport any objects underneath the driver or passenger seat.
- Secure the toolkit.◀
- Do not damage the angular rate sensor.
- Bear in mind that the DTC function is not available or the functionality is subject to certain restrictions.
- You can continue to ride. Bear in mind the more detailed in-

formation on situations that can lead to a DTC fault (►► 150).

- Have the fault rectified as quickly as possible by a specialist workshop, preferably an authorised BMW Motorrad dealer.

D-ESA fault



General warning light shows yellow.



Spring strut adjustment faulty! Onward journey possible. Ride carefully to next specialist workshop.

Possible cause:

The D-ESA control unit has detected a fault. The damping and/or spring adjuster may be the cause. In Auto the cause may also be a fault in the riding position equaliser. In this condition, the motorcycle may have too much damping and is uncom-

fortable to drive, especially on roads in poor condition. Alternatively, the spring preload may be incorrectly adjusted.

- Have the fault rectified as quickly as possible by a specialist workshop, preferably an authorised BMW Motorrad dealer.

Fuel down to reserve



Fuel reserve reached. Go to a filling station soon.



WARNING

Irregular engine operation or engine shutdown due to lack of fuel

Risk of accident, damage to catalytic converter

- Do not run the fuel tank dry. ◀

Possible cause:

The fuel tank contains no more than the reserve quantity of fuel.

 Reserve fuel
approx. 4 l

- Refuelling (►► 139).

Hill Start Control activated

– with riding modes Pro^{OE}



The holding symbol is displayed.

Possible cause:

The driver has activated Hill Start Control (►► 157).

- Switch off Hill Start Control.
- Operate Hill Start Control (►► 85).

Hill Start Control is deactivated automatically

– with riding modes Pro^{OE}



General warning light flashes yellow.



The holding symbol flashes briefly.

Possible cause:

Hill Start Control has been switched off automatically.

- The side stands have been folded out.
- » Hill Start Control is deactivated when the side stands are folded out.
- The engine has been stopped.
- » Hill Start Control is deactivated when the engine is stopped.
- The motorcycle has been drive off with Hill Start Control activated.
- Operate Hill Start Control (▣▶ 85).

Hill Start Control cannot be activated

– with riding modes Pro^{OE}



General warning light flashes yellow.



The holding symbol flashes briefly.

Possible cause:

Hill Start Control cannot be activated.

- Retract the side stand.
- » Hill Start Control functions only when the side stands are folded in.
- Start the engine.
- » Hill Start Control functions only when the engine is running.

Gear not trained

– with shift assistant Pro^{OE}



The gear indicator flashes. The Pro shift assistant is not available.

Possible cause:

– with shift assistant Pro^{OE}

The gearbox sensor is not fully trained.

- Engage neutral gear N and, with the vehicle at a standstill, let the engine run for at least 10 seconds to train the idle gear.
- Engage all gears with clutch actuation and ride at least 10 seconds with the engaged gear.
- » The gear indicator starts to flash when the gearbox sensor has been trained successfully.
- When the gearbox sensor is fully trained, the Pro shift assistant functions as described (▣▶ 156).
- If the training process was not successful, have the fault rectified by a specialist workshop, preferably an authorised BMW Motorrad dealer.

Hazard warning lights system is switched on



Turn signal indicator light flashes green.



Turn signal indicator light flashes green.

Possible cause:

The driver has switched on the hazard warning lights system.

- Operating hazard warning flashers (➡ 69).

Service-due indicator



If service is overdue, the due date or the odometer reading at which service was due is accompanied by the 'General' warning light showing yellow.

If the service is overdue, a yellow CC message is displayed. Exclamation marks also draw your attention to the displays for service, service appointment and remaining distance in the

MY VEHICLE and SERVICE REQUIREMENTS menu screens.



NOTICE

If the service-due indicator appears more than a month before the service date, the current date has to be corrected. This situation can occur if the battery was disconnected. ◀

Service due



is displayed in white.

Service due! Have service carried out by a BMW Motorrad Retailer.

Possible cause:

Service is due because of the driving performance or the date.

- Have your motorcycle serviced regularly by a specialist workshop, preferably by an authorised BMW Motorrad retailer.

- » The operational and road safety of the motorcycle remain intact.
- » The motorcycle's value is maintained as best as possible.

Service-due date has passed



General warning light shows yellow.



is displayed in yellow.

Service overdue! Have service carried out by a BMW Motorrad Retailer. Possible cause:

Service is overdue because of the driving performance or the date.

- Have your motorcycle serviced regularly by a specialist workshop, preferably by an authorised BMW Motorrad retailer.

- » The operational and road safety of the motorcycle remain intact.
- » The motorcycle's value is maintained as best as possible.

Operation

Ignition switch/steering lock	56	PRO riding mode	80
Ignition with Keyless Ride	58	Cruise-control system	82
Emergency off switch (kill switch)	62	Hill Start Control	85
Intelligent emergency call	62	Anti-theft alarm (DWA)	86
Lights	65	Tyre pressure monitoring (RDC)	89
Day run lights	67	Heated handlebar grips	89
Hazard warning lights system	69	On-board computer	90
Turn indicators	69	Front and rear seats	91
Anti-lock brake system (ABS)	70		
Automatic Stability Control (ASC)	71		
Dynamic Traction Control (DTC)	73		
Electronic Suspension Adjustment (D-ESA)	75		
Riding mode	78		

Ignition switch/steering lock

Keys

You receive 2 ignition keys. Please observe the information about the electronic immobiliser (EWS) if a key is lost (►► 57). Ignition switch/steering lock, fuel filler cap lock and seat lock are all operated with the same key.

If you wish you can arrange to have the cases and the top-case fitted with locks that can be opened with the ignition key as well. Consult a specialist workshop, preferably an authorised BMW Motorrad dealer.

Lock the handlebars

- Turn the handlebars all the way to left.

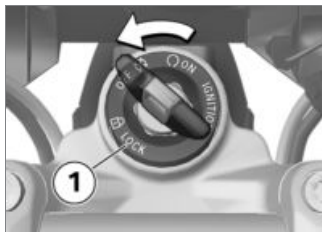

- Turn the key to position **1**, while moving the handlebars slightly.
 - » Ignition, lights and all function circuits switched off.
 - » Handlebars are locked.
 - » Key can be removed.

Switching on ignition

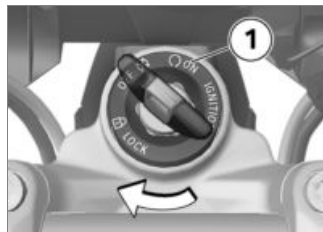

- Insert the key in the ignition switch and turn to position **1**.
 - » Side lights and all function circuits are switched on.
 - » Pre-Ride-Check is performed. (►► 130)
 - » ABS self-diagnosis is in progress. (►► 130)
 - without riding modes Pro^{OE}
 - » ASC self-diagnosis is performed. (►► 131)<
 - with riding modes Pro^{OE}
 - » DTC self-diagnosis is in progress. (►► 132)<

Welcome lights

- Switch on the ignition.
 - » The side lights briefly light up.
 - with daytime riding light^{OE}
 - » The daytime riding lights briefly light up.<
 - with LED auxiliary headlights^{OA}
 - » The LED auxiliary headlights briefly light up.<

Switching off ignition

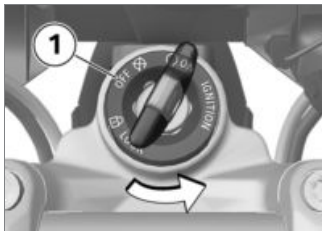

- Turn the ignition key to position **1**.
 - » When the ignition is switched off, the instrument cluster remains switched on for a short

- time and displays any existing fault messages.
 - » Handlebars not locked.
 - » Electrically powered accessories remain operational for a limited period of time.
 - » The battery can be recharged via the socket.
 - » Key can be removed.

- with daytime riding light^{OE}
 - The daytime riding light goes out soon after the ignition is switched off.<
- with LED auxiliary headlights^{OA}
 - The LED auxiliary headlights go out soon after the ignition is switched off.<

Electronic immobiliser EWS

The electronic design of the motorcycle allows it to access data stored in the ignition key by means of a ring antenna loc-

ated in the ignition switch/steering lock. The engine control unit will not permit the engine to be started unless the key is identified as “authorised”.



NOTICE

A spare key attached to the same ring as the ignition key used to start the engine could “irritate” the electronics, in which case the enabling signal for starting is not issued. Always keep the spare key separately from the ignition key.<

If you lose your key, you can have it barred by your authorised BMW Motorrad dealer. If you wish to do this, you will need to bring all other keys for the motorcycle with you. The engine cannot be started by a barred key, but a key that has been barred can subsequently be reactivated.

You can obtain emergency/extra keys only through an authorised BMW Motorrad dealer. The keys are part of an integrated security system, so the dealer is under an obligation to check the legitimacy of all applications for replacement/extra keys.

Ignition with Keyless Ride

– with Keyless Ride^{OE}

Keys

NOTICE

The telltale light for the radio-operated key flashes while the search for the radio-operated key is in progress.

The telltale light goes out as soon as the radio-operated key or the emergency key is found. The telltale light goes out briefly if the search times out without

the radio-operated key or the emergency key being found. ◀

You receive one radio-operated key and one emergency key. Please observe the information about the electronic immobiliser (EWS) if a key is lost (➡ 57). Ignition, fuel filler cap and anti-theft alarm system all work with the radio-operated key. Seat lock, topcase and cases can be locked and unlocked manually.

NOTICE

The vehicle cannot be started if the radio control key is not within range (e.g. key inside one of the cases or the topcase).

If the radio-operated key remains out of range the ignition is switched off after about 1.5 minutes to protect the battery. It is advisable to keep the radio-operated key on your person (e.g. in a jacket pocket) and to

have the emergency key with you as an alternative. ◀

	Range of the Keyless Ride radio-operated key
– with Keyless Ride ^{OE}	
approx. 1 m ◀	

Lock the handlebars

Requirement

The handlebars are turned towards the left. Radio-operated key is within range.

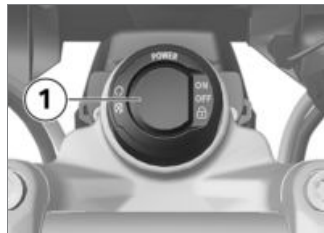

- Press and hold down button **1**.

- » The steering lock engages with an audible click.
- » Ignition, lights and all function circuits switched off.
- Short-press button **1** to disengage the steering lock.

Switching on ignition

Requirement

Radio-operated key is within range.

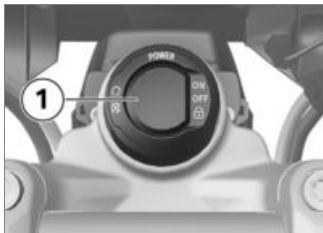

- There are **two** ways of activating the ignition.

Version 1:

- Briefly press button **1**.
 - » Side lights and all function circuits are switched on.
 - with daytime riding light^{OE}
 - » Daytime riding light is switched on.<
 - with LED auxiliary headlights^{OA}
 - » LED auxiliary headlights are switched on.<
 - » Pre-Ride-Check is performed. (▶▶▶ 130)
 - » ABS self-diagnosis is in progress. (▶▶▶ 130)
 - without riding modes Pro^{OE}
 - » ASC self-diagnosis is performed. (▶▶▶ 131)<

Version 2:

- Steering lock is engaged; press and hold down button **1**.
 - » The steering lock disengages.
 - » Parking lights and all function circuits switched on.

- » Pre-Ride-Check is performed. (▶▶▶ 130)
- » ABS self-diagnosis is in progress. (▶▶▶ 130)
 - without riding modes Pro^{OE}
- » ASC self-diagnosis is performed. (▶▶▶ 131)<

Switching off ignition

Requirement

Radio-operated key is within range.



- There are **two** ways of deactivating the ignition.

Version 1:

- Short-press button **1**.
- » Light is switched off.
- » Handlebars (steering lock) are not locked.

Version 2:

- Turn the handlebars all the way to left.
- Press and hold down button **1**.
- » Light is switched off.
- » The steering lock engages.

**Electronic immobiliser
EWS**

The on-board electronics access the data saved in the radio-operated key via a ring aerial in the wireless lock. The ignition is not enabled for starting until the engine control unit has recognised the radio-operated key as "authorised" for your motorcycle.

**NOTICE**

A spare key attached to the same ring as the radio-operated key used to start the engine could "irritate" the electronics, in which case the enabling signal for starting is not issued.

Always keep the spare key separate from the radio-operated key. ◀

If you mislay a radio-operated key you can have the key in question barred by your authorised BMW Motorrad dealer. In order to have a key barred you must bring along all the other keys belonging to the motorcycle.

The engine cannot be started by a barred radio-operated key, but a radio-operated key that has been barred can subsequently be reactivated.

You can obtain emergency/extra keys only through an author-

ised BMW Motorrad dealer. The radio-operated keys are part of an integrated security system, so the dealer is under an obligation to check the legitimacy of all applications for replacement/extra keys.

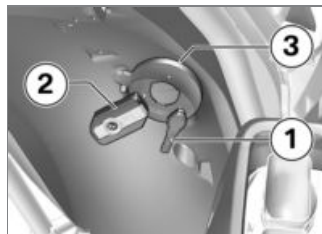
Battery of the radio-operated key is flat or the key has been lost

- Please consult the information on the electronic immobiliser (**EWS**) if a key is lost or mislaid.
- If you happen to lose or mislay the radio-operated key while

on a journey, you can start the vehicle with the emergency key.

- If the battery of the radio-operated key is flat, the motorcycle can be started by touching the rear-wheel cover with the radio-operated key.
- Hold the emergency key **1** or the flat radio-operated key **2** against the rear-wheel cover at the same height as the antenna **3**.

NOTICE

The emergency key or the radio-operated key with the empty battery must be **in contact with** the rear-wheel cover. ◀

	Time during which the engine has to be started. The unlocking procedure has to be repeated if this time is allowed to expire.
30 s	

- » Pre-Ride-Check is performed.
- Key has been recognised.
- Engine can be started.
- Starting the engine (➡ 129).

Replace the battery of the radio-operated key

If the radio-operated key does not react when you short-press or long-press a button:

- The battery in the radio-operated key is not at full capacity.



Remote key battery weak. Limited central locking function. Change battery.

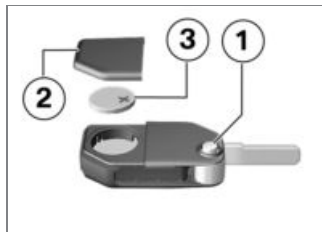

- Press button **1**.
- » Key bit flips out.
- Push up battery cover **2**.
- Remove the battery **3**.
- Dispose of the old battery in accordance with all applicable laws and regulations; do not attempt to dispose of batteries as domestic waste.



ATTENTION

Unsuitable or incorrectly inserted batteries
Component damage

- Use a battery compliant with the manufacturer's specifications.
- When inserting the battery, always make sure polarity is correct.◀
- Insert the new battery with the positive terminal up.



Battery type

for Keyless Ride-radio-operated key

CR 2032

- Remove the battery **2**.
- » Red LED on the instrument panel flashes.
- » The radio-operated key is ready for use again.

Emergency off switch (kill switch)



- 1** Emergency off switch (kill switch)



WARNING

Operation of the kill switch while riding

Risk of fall due to rear wheel locking

- Do not operate the kill switch when riding.◀

The emergency off switch is a kill switch for switching off the engine quickly and easily.

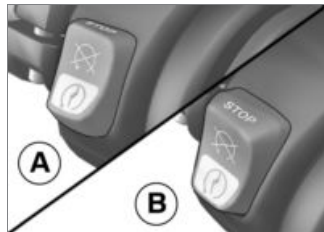

- A** Engine switched off
B Normal operating position (run)

Intelligent emergency call

- with intelligent emergency call^{OE}

Emergency call via BMW

Press the SOS button in an emergency only.

Even if an emergency call using BMW is not possible, the system may make an emergency call to a public emergency call number. This depends on the respective mobile phone network and the national regulations.

The emergency call is not able to be ensured because of technical reasons due to unfavourable conditions, e.g. in areas where there is no mobile phone reception.

Language for emergency call

Each vehicle has a language assigned to it depending on the market for which it is intended. The BMW Call Center answers in this language.

NOTICE

A changeover of the language for the emergency call can only be performed by the BMW Motorrad partner. The language assigned to the vehicle varies from the selectable language the driver can choose as the display language in the TFT display. ◀

Manual emergency call Requirement

An emergency call has occurred. The vehicle is at a standstill. The ignition is switched on.



- Open cover **1**.
- Briefly press SOS button **2**.

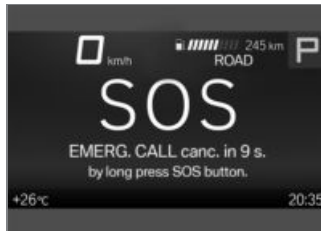

The time until transmission of an emergency call is displayed. During that time, it is possible to cancel the emergency call.

- Operate the emergency-off switch to stop the engine.
- Remove helmet.
- » After expiry of the timer, a voice contact to the BMW Call Center is established.

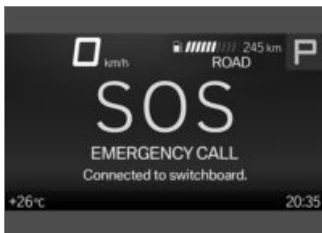

The connection was established.



- Provide information to the emergency services using the microphone **3** and speaker **4**.

Automatic emergency call

The intelligent emergency call is active after the ignition is switched on and reacts if a fall or crash occurs.

Emergency call in the event of a light fall

- A minor fall or a crash is detected.
- » An acoustic signal is sounded.

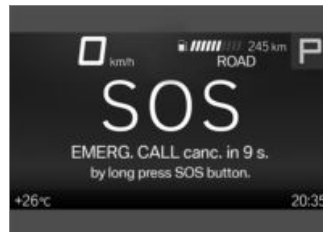

The time until transmission of an emergency call is displayed. During that time, it is possible to cancel the emergency call.

- If possible, remove helmet and stop engine.
- » A voice contact connection to the BMW Call Center is established.

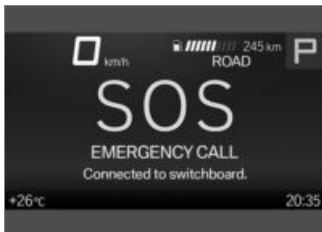

The connection was established.

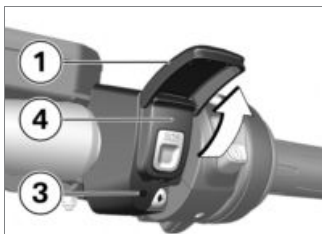

- Open cover **1**.
- Provide information to the emergency services using the microphone **3** and speaker **4**.

Emergency call in the event of a severe fall

- A severe fall or a crash is detected.
- » The emergency call is placed automatically without delay.

Lights

Low-beam headlight and sidelights

The side lights switch on automatically when the ignition is switched on.



The side lights place a strain on the battery. Do not switch the ignition on for longer than absolutely necessary. ◀

The low-beam headlight switches on automatically when the engine is started.

– with daytime riding light^{OE}
In daytime the daytime riding light can be switched on as an alternative to the low-beam headlight.

High-beam headlight and headlight flasher

- Switching on ignition (➡ 56).

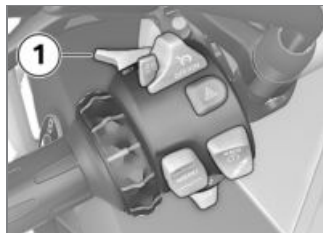

- Push switch **1** forward to switch on the high-beam headlight.
- Pull switch **1** back to operate the headlight flasher.

Headlight courtesy delay feature

- Switch off the ignition.



- Immediately after switching off the ignition, pull switch **1** back and hold it in that position until the headlight courtesy delay feature comes on.
 - » The vehicle lighting lights for one minute and is automatically switched back off.
 - This can be used after parking the vehicle, for example, to light the way to the house door.

Parking lights

- Switching off ignition (☞ 57).



- Immediately after switching off the ignition, push button **1** to the left and hold it in that position until the parking lights come on.
- Switch the ignition on and off again to switch off the parking lights.

Auxiliary headlights

- with LED auxiliary headlights^{OA}

Requirement

The additional headlights are active only when the low-beam headlight is active.

NOTICE

The auxiliary headlights have approval as fog lights and their use is permissible in bad weather conditions only. Always comply with the road traffic regulations in force in the country in which the vehicle is used.◀

- Starting the engine (☞ 129).



- Press button **1** to switch on the additional headlights.

 The indicator light for the auxiliary headlight illuminates.

- Press button **1** again to switch off the additional headlights.

Day run lights

– with daytime riding light^{OE}

Manual daytime riding light

Requirement

Automatic daytime riding light is switched off.

WARNING

Activation of daytime riding light in the dark.

Poorer vision and oncoming traffic dazzled.

- Do not use the daytime running light when it is dark. ◀

NOTICE

By comparison with the low-beam headlight, the daytime running light makes the vehicle more visible to oncoming traffic. This improves daytime visibility. ◀

- Starting the engine (➡ 129).
- In the Settings, Vehicle settings, Lights menu,

switch off the Auto. daytime light function.



- Press button **1** to switch on the daytime riding light.

 The indicator light for the daytime riding light lights up.

- » The low-beam headlight and the front side lights are switched off.
- In the dark or in tunnels: press button **1** again to switch off the daytime riding light and switch on the low-beam headlight and front side light.

**NOTICE**

If the high-beam headlight is switched on while the daytime riding light is on, the daytime riding light is switched off after approx. 2 seconds and the high-beam headlight, low-beam headlight and front side light are switched on.

If the high beam headlight is switched off again, the daytime running light is not automatically reactivated, but must be switched on again if required.◀

Automatic daytime riding light**NOTICE**

The changeover between daytime riding light and low beam headlight incl. front side lights can be effected automatically.◀

**WARNING**

The automatic riding light control system cannot replace your personal assessment of lighting conditions, particularly in foggy or misty weather.

Safety risk

- Manually switch on the low-beam headlight in poor lighting conditions.◀
- In the Settings, Vehicle settings, Lights menu, switch on the Auto. daytime light function.



The indicator light for the automatic daytime riding light lights up.

- » If the ambient brightness decreases below a certain value, the low beam headlight is automatically switched on (e. B. in a tunnel). When sufficient ambient brightness is detected, the

daytime riding light is switched back on.



The indicator light for the daytime riding light shows if the daytime riding light is active.

Manual operation of the light when the automatic system is switched on

- If you press the button for the daytime riding light the daytime riding light is switched off and the low-beam headlight and front side lights are switched on (e. g. when you ride into a tunnel, and the response of the automatic daytime riding light to the change in ambient brightness is delayed).
- If you press the button again the daytime riding light is re-activated, in other words the daytime riding light is switched on again when ambient light is bright enough.

Hazard warning lights system

Operating hazard warning flashers

- Switching on ignition (▣▣▣▣ 56).



NOTICE

The hazard warning flashers place a strain on the battery. Do not use the hazard warning flashers for longer than absolutely necessary. ◀



- Press button **1** to switch on the hazard warning lights system.
» Ignition can be switched off.
- To switch off the hazard warning lights system, switch on the ignition if necessary and press button **1** again.

Turn indicators

Operating the turn indicators

- Switching on ignition (▣▣▣▣ 56).



- Push button **1** to the left to switch on the left turn indicators.
- Push button **1** to the right to switch on the right turn indicators.
- Operate button **1** in centre position to cancel the turn indicators.

 Turn indicator cancellation

The turn indicators are cancelled automatically after the defined riding time and distance.

Anti-lock brake system (ABS)

Deactivating the ABS function

- Switching on ignition (➡ 56).

NOTICE

You have the option of deactivating the ABS function while the motorcycle is on the move. ◀



- Press and hold button **1** until the ABS indicator and warning light changes its status.

Immediately after the button **1** is pressed, the system statuses for ASC/DTC and ABS are displayed as ON.

- » Initially the ASC indicator and warning light changes status. Press and hold button **1** until the ABS indicator and warning light changes its status. In this case, the ASC/DTC setting does not change.



ABS telltale and warning light shows.

Possible ABS system status OFF! is displayed.

- Release button **1** once the ABS system status has changed.

The ASC/DTC system status remains unchanged and a new ABS system status OFF! is briefly displayed.



ABS telltale and warning light remains on.

- » The ABS function is switched off.
- » The integral function remains active.
 - with riding modes Pro^{OE}
- » Hill Start Control is still activated. ◀
- See the section entitled "Engineering details" for more information on brake systems with BMW Motorrad Integral ABS .
 - » Partially integral brakes (➡ 146)
 - with riding modes Pro^{OE}
 - » Hill Start Control function (➡ 157) ◀

Activating the ABS function



- Press and hold button **1** until the ABS indicator and warning light changes its status.

Immediately after the button **1** is pressed, the system statuses for ASCDTC and ABS are displayed as OFF!.

-  ABS telltale and warning light goes out; if self-diagnosis has not completed it starts flashing.

Possible ABS system status ON is displayed.

- Release button **1** once the ABS system status has changed.

-  ABS telltale and warning light remains off or continues to flash.

The ASCDTC system status remains unchanged and a new ABS system status ON is briefly displayed.

- » The ABS function is switched on.
- You also have the option of switching the ignition off and then on again.

 An ABS fault has occurred if the ABS telltale and warning light shows when the motorcycle accelerates to a speed in excess of the minimum stated below after the ignition was switched off and then on again.

min 10 km/h

- with riding modes Pro^{OE}
- If the encoding plug is not inserted, you have the alternative of switching the ignition off and back on again.<

Automatic Stability Control (ASC)

Deactivating the ASC function

- without riding modes Pro^{OE}
- Switching on ignition (➡ 56).

NOTICE

You have the option of deactivating the ASC function while the motorcycle is on the move. ◀◀



- Press and hold button **1** until the ASC indicator light changes its status.

Immediately after button **1** is pressed, ASC system status **ON** and current ABS system status are displayed.

 ASC telltale and warning light shows.

Possible ABS system status **OFF!** is displayed.

- Release button **1** once the ASC system status has changed.

The new ASC system status **OFF!** is briefly displayed. The ABS system status remains unchanged.

 ASC telltale and warning light remains on.

» The ASC function is switched off.

Activating the ASC function

– without riding modes Pro^{OE}



- Press and hold button **1** until the ASC indicator light changes its status.

Immediately after button **1** is pressed, ASC system status **OFF!** and current ABS system status are displayed.

 ASC indicator and warning light no longer lights up and starts flashing if the self-diagnosis is incomplete.

Possible ABS system status **ON** is displayed.

- Release button **1** once the status has changed.

 ASC indicator and warning light remains off or continues flashing.

The new ASC system status **ON** is briefly displayed. The ABS system status remains unchanged.

- » The ASC function is switched on.
- If the encoding plug is not inserted, you have the alternative of switching the ignition off and then on again.

NOTICE

See the section entitled "Engineering details" for more information on BMW Motorrad Automatic Stability Control (ASC).◀

 An ASC fault has occurred if the ASC indicator and warning light shows when the motorcycle accelerates to a speed in excess of the minimum stated below after the ignition was switched off and then on again.

min 5 km/h

- See the section entitled "Engineering details" for more information on Automatic Stability Control.
- » How does ASC work? (▶▶▶ 149)

Dynamic Traction Control (DTC)

– with riding modes Pro^{OE}

DTC Switching off

- Switch on the ignition.

NOTICE

You have the option of deactivating the DTC function while the motorcycle is on the move.◀



- Press and hold button **1** until the DTC indicator light changes its status. Immediately after button **1** is pressed, DTC system status **ON** and current ABS system status are displayed.

 DTC indicator and warning light shows.

Possible DTC system status OFF! is displayed.

- Release button **1** once the status has changed.

The new DTC system status OFF! is briefly displayed. The ABS system status remains unchanged.

 DTC indicator and warning light remains on.

- » The DTC function is switched off.

DTC Switching on



- Press and hold button **1** until the DTC indicator light changes its status.

Immediately after button **1** is pressed, DTC system status OFF! and current ABS system status are displayed.

 DTC indicator and warning light goes out; if self-diagnosis has not completed, it starts flashing.

Possible DTC system status ON is displayed.

- Release button **1** once the status has changed.

 DTC indicator and warning light remains off or continues to flash.

The new DTC system status ON is briefly displayed. The ABS system status remains unchanged.

- » The DTC function is switched on.
- If the encoding plug is not inserted, you have the alternative of switching the ignition off and then on again.



A DTC fault has occurred if the DTC telltale light shows when the motorcycle accelerates to a speed in excess of the minimum stated below after the ignition was switched off and then on again.

min 5 km/h

- See the section entitled "Engineering details" for more information on Dynamic Traction Control:
 - » How does traction control work? (►►► 150)

Electronic Suspension Adjustment (D-ESA)

- with Dynamic ESA^{OE}

Dynamic ESA possible settings

The electronic chassis and suspension adjustment Dynamic ESA is able to adjust your motorcycle automatically to the load. If the spring preload is set to **Auto**, the rider does not have to change the load settings. See the section "Engineering details" for more information on Dynamic ESA (►►► 152).

Available damping modes

- For on-road mode: Road and Dyna.
- For off-road mode: Enduro

Available load settings

- Fixed set minimum spring preload: Min
- Activated riding position equaliser with automatic adjustment of the spring preload: Auto
- Fixed set maximum spring preload: Max

Viewing suspension settings

- Switching on ignition (►►► 56).



- Press button **1** briefly to view the current setting.

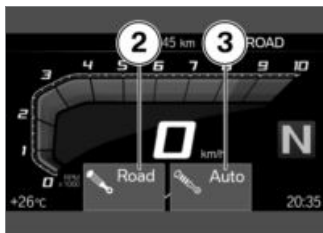

Immediately after button **1** is pressed, the chassis and suspension settings for damping action **2** and spring preload **3** are displayed.

» The setting shows briefly, then disappears automatically.

Adjusting the chassis and suspension

- Switching on ignition (➡ 56).



- Press button **1** briefly to view the current setting.
- To adjust damping:
- Repeatedly press button **1** briefly until the setting you want to use appears on the display.



NOTICE

You can adjust the damping characteristic while the motorcycle is on the move.◀

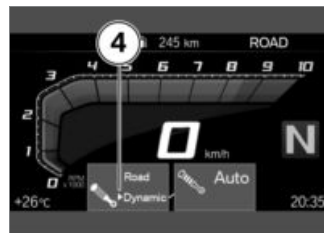

The selection arrow **4** appears on the display.

» The selection arrow **4** disappears after the status is changed.

The following settings are available:

- Road: Damping for comfortable on-road mode
- Dyna.: Damping for dynamic on-road mode
- Enduro: Damping for off-road mode. Only available in ENDURO or ENDURO PRO riding modes and can also not be

adjusted further in these riding modes.

A message is displayed if a setting is not possible in the selecting riding mode. Example: ENDURO riding mode: damping not adjusted.



To adjust spring preload:

- Starting the engine (➔ 129).
- Repeatedly press and hold button **1** until the setting you want to use appears on the display.

NOTICE

BMW Motorrad recommends using the **Max** setting for off-road operation and the **Min** setting for better ground accessibility. ◀

NOTICE

The **Min**, **Auto** and **Max** settings can be chosen only when the vehicle is stationary. ◀

The following message is issued if it is not possible to adjust a setting: Load adjustment only avail. stopped.

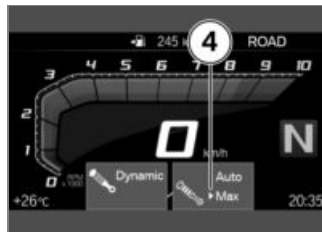

The selection arrow **4** appears on the display.

» The selection arrow **4** disappears after the status is changed.

The following settings are available:

- **Min**: Minimum spring preload
- **Auto**: Automatic setting of spring preload
- **Max**: Maximum spring preload

» The settings for damping and spring preload shown on the display are automatically accepted if you allow a certain

length of time to pass without pressing button **1**.

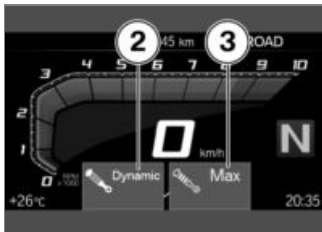

The new chassis and suspension settings for damping action **2** and spring preload **3** are displayed briefly.

- If the temperature is very low, take the weight off the motorcycle before increasing spring preload; if applicable, have your passenger dismount.
- » The chassis and suspension settings disappear once adjustment is complete.
- » In *Auto* loading mode, the spring preload is adjusted only

once the motorcycle is driven off.

Riding mode

Using the riding modes

BMW Motorrad has developed operational scenarios for your motorcycle from which you can select the scenario suitable for your situation:

Series

- **RAIN**: Riding on a rain-wet road surface.
- **ROAD**: Riding on a dry road surface.

– with riding modes Pro^{OE}

with Pro riding modes

- **DYNAMIC**: Dynamic riding on a dry road surface.
- **ENDURO**: Riding off-road with road tyres.

with Pro riding modes and installed encoding plug

- **DYNAMIC PRO**: Dynamic riding on dry roadways while taking into account the settings made by the rider.
- **ENDURO PRO**: Riding off-road with off-road tyres with large tread blocks while taking into account the settings made by the rider.

When an encoding plug is installed, the **DYNAMIC PRO** and **ENDURO PRO** riding modes replace the **DYNAMIC** and **ENDURO** riding modes.

The interplay of throttle response, ABS control and ASC/DTC control is optimised for each of the scenarios.

– with Dynamic ESA^{OE}

The chassis and suspension adjustment can also be adjusted in the scenario selected.

See the section "Engineering details" for more information on the riding modes (→ 152).

Select riding mode

- Switching on ignition (→ 56).



- Press button 1.



The activated riding mode 2 fades into the background and the first selectable riding mode 3 is displayed. The guide 4 displays how many riding modes are available.



ATTENTION

Activation of the off-road mode (Enduro and Enduro Pro) when riding on-road.

Risk of crash due to lack of stability when the vehicle brakes or accelerates in the control range of ABS or ASC/DTC

- Activate off-road mode (Enduro and Enduro Pro) only for off-road riding. ◀
- Repeatedly press button 1 until the desired riding mode is displayed.

**NOTICE**

When selecting the **ENDURO PRO** riding mode: bear in mind that ABS control is deactivated for the rear wheel.◀

The following ride modes can be selected:

- **RAIN**: For riding on a rain-wet roadway.
- **ROAD**: For riding on a dry roadway.

– with riding modes Pro^{OE}

The following riding modes are additionally available for selection:

- **DYNAMIC**: For dynamic riding on a dry roadway.
- **ENDURO**: When riding off-road with road tyres.<

– with riding modes Pro^{OE}

When an encoding plug is installed, the **ENDURO PRO** and **DYNAMIC PRO** riding modes re-

place the **ENDURO** and **DYNAMIC** riding modes.

– **DYNAMIC PRO**: For dynamic riding on dry roadways while taking into account the settings made by the rider.

– **ENDURO PRO**: For riding off road with off-road tyres with large tread blocks while taking into account the settings made by the rider.<

» With the motorcycle at a standstill, the selected mode is activated after approximately two seconds.

» The newly selected riding mode is activated as you ride only when the following preconditions are satisfied:

- Throttle grip is in idle position.
- Brake is not applied.

» The set riding mode with the relevant adjustments in engine characteristics, ABS, ASC / DTC and Dynamic ESA

also remains once the ignition has been switched off.

PRO riding mode

– with riding modes Pro^{OE}

Adjustment option

The **PRO** riding modes can be set individually.

Setting up PRO riding mode

- Installing encoding plug (▣▶ 81).
- Switching on ignition (▣▶ 56).
- Call up the **Settings, Vehicle settings** menu.
- » The following **PRO** riding modes can be adjusted:
 - **ENDURO PRO** riding mode
 - **DYNAMIC PRO** riding mode
- Select and confirm riding mode.

Setting up Enduro Pro

- with riding modes Pro^{OE}
- Setting up PRO riding mode (▣▣▣▣ 80).

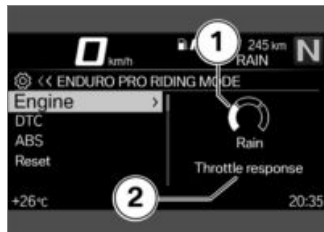

The Engine system has been selected. The current setting is displayed as a diagram **1** with an explanatory text relating to System **2**.

- Select system and confirm.



You can browse through the available settings **3** and the corresponding explanations **4**.

- Setting up system.
 - » The Engine, DTC and ABS systems can be set up in the same way.
- The settings can be reset to the factory settings:
- Resetting riding mode settings (▣▣▣▣ 81).

Setting up Dynamic Pro

- Setting up PRO riding mode (▣▣▣▣ 80).
- Setting up ENDURO PRO riding mode.

NOTICE

ABS can only be set in the Enduro PRO riding mode.◀

Resetting riding mode settings

- Setting up PRO riding mode (▣▣▣▣ 80).
- Select *Reset* and confirm.
 - » The following factory settings apply for ENDURO PRO RIDING MODE:
 - DTC: Enduro Pro
 - ABS: Enduro Pro
 - Engine: ROAD
 - » The following factory settings apply for DYNAMIC PRO RIDING MODE:
 - DTC: Dynamic
 - ENGINE: Dynamic

Installing encoding plug

- Switching off ignition (▣▣▣▣ 57).

- Removing front seat (➡ 92).



ATTENTION

Dirt and damp penetrating inside open connectors

Malfunctions

- Reinstall the protective cap after removing the coding plug. ◀
- Remove the cover cap from the plug connection **1**.



- To do so, press in latch **1** and remove the cap.
- Install the encoding plug.
- Switch on the ignition.



The symbol for the encoding plug **1** is displayed. The **ENDURO PRO** and **DYNAMIC PRO** riding

modes can be selected and replace the **ENDURO** and **DYNAMIC** riding modes.

- Installing front seat (➡ 93).

Cruise-control system

– with cruise control^{OE}

Display when adjusting settings (Speed Limit Info not active)



The symbol **1** for cruise control is displayed in the Pure Ride view and the top status line.

Display when adjusting settings (Speed Limit Info active)



The symbol **1** for cruise control is displayed in the Pure Ride view and the top status line.

Switching on cruise control

Requirement

Cruise control is available only after changing out of the Enduro or Enduro Pro riding modes.

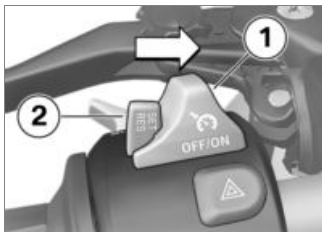

- Slide switch **1** to the right.
» Button **2** is operational.

Saving road speed

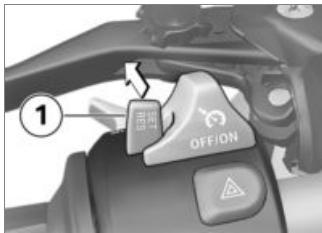

- Briefly push button **1** forward.

 Adjustment range for cruise control (depending on gear)

20...210 km/h

 Telltale light for cruise control shows.

» The motorcycle maintains your current cruising speed and the setting is saved.

Accelerating

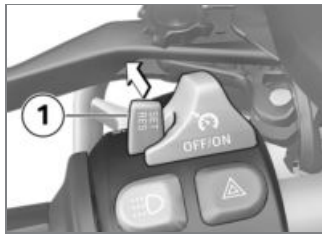

- Briefly push button **1** forward.

- » Speed is increased by approx. 2 km/h each time you push the button.
- Push button **1** forward and hold it in this position.
- » The motorcycle accelerates steplessly.
- » The current speed is maintained and saved if button **1** is not pushed again.

Decelerating

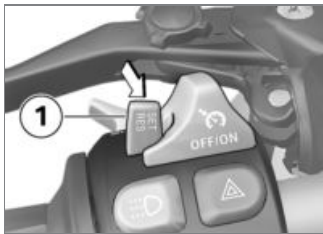

- Briefly push button **1** back.
- » The speed is reduced by 2 km/h each time you push the button.

- Push button **1** back and hold it in this position.
- » The motorcycle decelerates steplessly.
- » The current speed is maintained and saved if button **1** is not pushed again.

Deactivate cruise control

- Brake, pull the clutch lever or turn the throttle twistgrip (close the throttle by turning the twistgrip back past the idle position) to deactivate the cruise-control system.
- » Telltale light for cruise control goes out.

Resuming former cruising speed

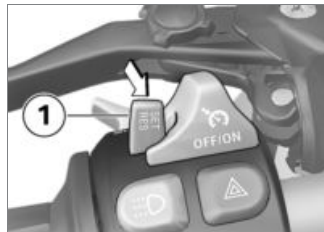

- Briefly push button **1** back to return to the speed saved beforehand.

NOTICE

Opening the throttle does not deactivate the cruise-control system. If you release the twistgrip the motorcycle will decelerate only to the cruising speed saved in memory, even though you might have intended slowing to a lower speed.◀



Telltale light for cruise control shows.

Switching off cruise control

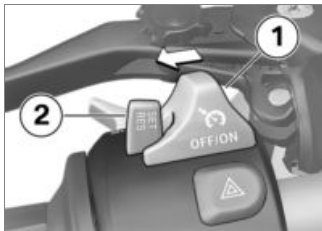

- Slide switch **1** to the left.
- » The system is deactivated.
- » Button **2** is disabled.

Hill Start Control

– with riding modes Pro^{OE}

Reading

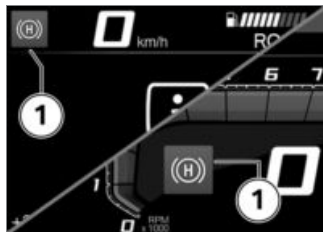

The symbol **1** for drive-off assistant is displayed in the Pure Ride view and the top status line.

Operate Hill Start Control Requirement

The vehicle is at a standstill.



ATTENTION

Switching off the engine or ignition, extending the side stand, timeout (approx. 20 minutes) or in the event of a fault

Hill Start Control brake failure

- It is essential to apply the brakes manually to hold the vehicle.◀



NOTICE

Hill Start Control is purely a comfort system to facilitate holding the machine and pulling way on uphill gradients and should not be confused with a parking brake.◀

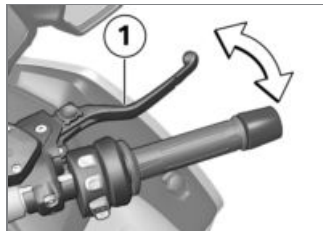

- Operate the parking brake lever **1** with force and release it again quickly.

 The holding symbol is displayed.

- » Hill Start Control has been activated.
- To switch off Hill Start Control, operate the parking brake lever **1** again.

 The holding symbol disappears.

- Or drive off in first or second gear.

NOTICE

Hill Start Control is deactivated automatically when driving off. ◀

 General warning light flashes yellow.

 The holding symbol flashes briefly.

 Once the brake has been fully released, the holding symbol disappears.

- » Hill Start Control has been switched off.
- See the section entitled "Engineering details" for more information on Hill Start Control.
- » Hill Start Control function (▶▶▶ 157)

Anti-theft alarm (DWA) Activation

– with alarm system (DWA)^{OE}

- Switching on ignition (▶▶▶ 56).
- Customising anti-theft alarm settings (▶▶▶ 88).
- Switch off the ignition.
 - » If the alarm system is activated, then the alarm system will be automatically activated when the ignition is switched off.
 - » Activation takes approximately 30 seconds to complete.
 - » Turn indicators flash twice.
 - » Confirmation tone sounds twice (if programmed).

- » Anti-theft alarm is active.
 - with Keyless Ride^{OE}

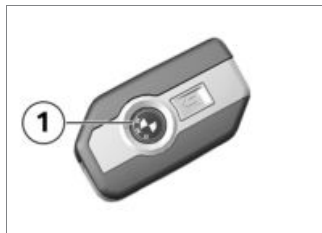

- Switch off the ignition.
- Press button **1** on the radio-operated key twice.
 - » Activation takes approximately 30 seconds to complete.
 - » Turn indicators flash twice.
 - » Confirmation tone sounds twice (if programmed).
 - » Anti-theft alarm is active.

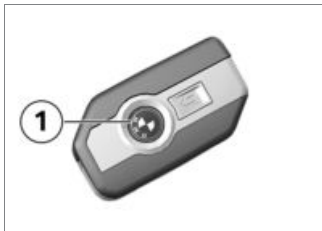

Alarm signal

– with alarm system (DWA)^{OE}

A DWA alarm can be triggered by:

- Motion sensor
- Switch-on attempt with an unauthorised vehicle key.
- Disconnection of the DWA anti-theft alarm from the motorcycle's battery (DWA internal battery provides power - alarm tone only, the turn indicators do not flash)

All functions are sustained even if the internal battery of the DWA anti-theft alarm system is flat; the only difference is that an alarm cannot be triggered if the system is disconnected from the motorcycle's battery.

- Press button **1** again on the radio-operated key during the activation phase to deactivate the motion sensor (e.g. to transport the motorcycle by train when the severe movements may activate the alarm).
 - » Turn indicators flash three times.
 - » Confirmation tone sounds three times (if programmed).
 - » Motion sensor has been deactivated.

An alarm lasts for approximately 26 seconds. While an alarm is in progress an alarm tone sounds and the turn indicators flash. The type of alarm tone can be set by an authorised BMW Motorrad dealer.

– with Keyless Ride^{OE}

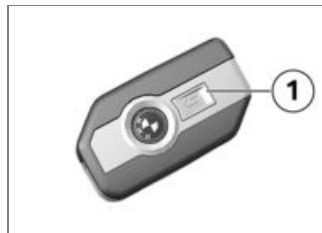

The activated alarm can be aborted at any time by pressing the **1** button on the radio-operated key, without deactivating the anti-theft alarm.

If an alarm was triggered while the motorcycle was unattended, the rider is notified accordingly by an alarm tone sounding once when the ignition is switched on. The DWA LED then indicates the reason for the alarm for one minute.

Light signals issued by the DWA LED:

- Flashes 1x: Motion sensor 1
- Flashes 2x: Motion sensor 2
- Flashes 3x: Ignition switched on with unauthorised vehicle key
- Flashes 4x: Disconnection of the anti-theft alarm from the motorcycle's battery
- Flashes 5x: Motion sensor 3

Deactivation

- with alarm system (DWA)^{OE}
 - Kill switch in operating position (run).
 - Switch on the ignition.

- » Turn indicators flash once.
- » Confirmation tone sounds once (if programmed).
- » DWA has been switched off.
- with Keyless Ride^{OE}

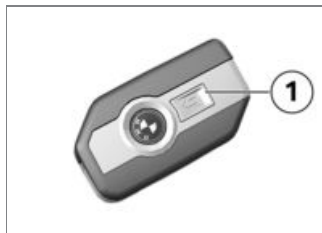

- Press button **1** on the radio-operated key once.



NOTICE

If the alarm function is deactivated by the remote control and the ignition is not subsequently switched on, the alarm function automatically goes active again after 30 seconds if "Ac-

tivation after ignition OFF" is programmed. ◀

- » Turn indicators flash once.
- » Confirmation tone sounds once (if programmed).
- » DWA has been switched off.

Customising anti-theft alarm settings

- Switching on ignition (➡ 56).
- Call up the **Settings**, **Vehicle settings**, **Alarm system menu**.
 - » The following settings are available:
 - Adapting **Warning signal**
 - Switching **Tilt sensor** on and off
 - Switching **Arming tone** on and off
 - Switching **Arm automatically** on and off
 - » Possible settings (➡ 89)

Possible settings

Warning signal: Set rising and falling or intermittent alarm tone.

Tilt sensor: Activate inclination sensor to monitor the inclination of the vehicle. The anti-theft alarm goes off in the event of wheel theft or towing, for example.

NOTICE

Deactivate the tilt sensor when transporting the vehicle to prevent the anti-theft alarm from being triggered.◀

Arming tone: Confirmation alarm tone after having activated/deactivated the DWA in addition to flashing turn indicators.

Arm automatically: Automatic activation of the alarm function when the ignition is switched off.

Tyre pressure monitoring (RDC)

– with riding modes Pro^{OE}

Switch minimum pressure warning on or off

- The minimum pressure of the tyres can be chosen freely. Once the minimum pressure has been reached, a minimum pressure warning can be displayed.
- Call up the **Settings**, **Vehicle settings**, **RDC** menu.
- Switch **Min. pressure alarm** on or off.

Heated handlebar grips

– with heated grips^{OE}

Operating the heated handlebar grips

NOTICE

The heating in the heated handlebar grips can be activated only when the engine is running.◀

NOTICE

The increase in power consumption caused by having the heated handlebar grips switched on can drain the battery if you are riding at low engine speeds. If the charge level is low, the heated handlebar grips are switched off to ensure the battery's starting capability.◀

- Starting the engine (➡ 129).

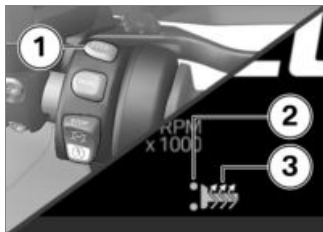

- Repeatedly press button **1** until the desired heating level **2** appears in front of the heated grip symbol **3**.

The handlebar grips have two-stage heating.

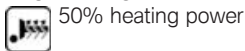

50% heating power



100% heating power

- » Stage 2 is for heating the grips quickly: it is advisable to switch back to stage 1 as soon as the grips are warm.

- » The selected heating stage will be saved if you allow a certain length of time to pass without making further changes.
- To switch off the heated grips, repeatedly press button **1** until the heated grip **3** is hidden.

On-board computer

Call up the on-board computer

- Call up the My Vehicle menu.
- Scroll to the right until the ON-BOARD COMPUTER menu screen is displayed.

Reset on-board computer

- Call up the on-board computer (▣▣▣ 90).
- Press down the MENU rocker button.
- Select `Reset all values` or `Reset individual values` and confirm.

The following values can be re-set:

- Break
- Journey
- Current
- ∅ Speed
- ∅ Consump.

Call up the journey computer

- Call up the on-board computer (▣▣▣ 90).
- Scroll to the right until the TRIP COMPUTER menu screen is displayed.

Reset journey computer

- Call up the journey computer (▣▣▣ 90).
- Press down the MENU rocker button.
- Select `Autom. reset` or `Reset all` and confirm.

Front and rear seats

Removing rear seat

- Place the motorcycle on its stand on firm, even ground.



- Turn the key clockwise in seat lock **1** and hold it in this position while pressing down the rear part of rear seat **2**.
- Lift the rear seat at the front and release the key.
- Remove the rear seat and place it, upholstered side down, on a clean surface.

Install the rear seat



ATTENTION

Damaged components

Damage to sensors, for example, which causes malfunctions

- Do not transport any objects underneath the driver or passenger seat.
- Secure the toolkit. ◀

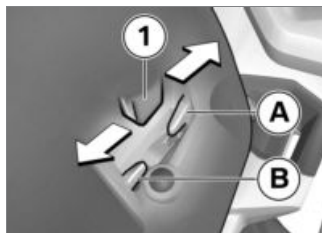

- Bear in mind the position of the rider's seat with regard to the direction for adjustment of the passenger seat.

- The rear seat can be set to either of 2 different positions.
- Centre both lugs **1** on the rear seat in the mounts.
- Rear seat position: Push passenger seat toward the rear **A**.
- Front seat position: Push passenger seat forward **B**.
- » Lugs **1** of the rear seat are correctly located.



- Press down firmly on passenger seat **1** at the front.
- » The passenger seat engages with an audible click.

Removing front seat

- Removing rear seat (➡ 91).

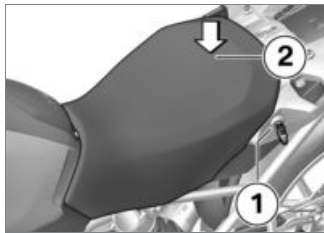

- Turn and hold the seat lock **1** to the left with the ignition key while pushing down the driver's seat at the rear **2**.
- Lift the driver's seat at the rear and release the key.
- Remove the driver's seat and place it on a clean surface with the upholstery facing down.

Setting the driver's seat height and inclination

- Removing front seat (➡ 92).

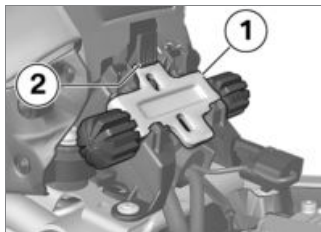

- To remove the front height adjustment **1**, push the locking mechanism forwards **2** and remove the height adjustment in an upwards direction.

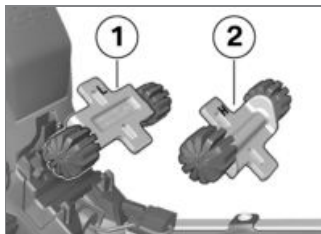

- To set the low seat position, install the height adjustment

and align it with **1** (identification L).

- To set the high seat position, install the height adjustment and align it with **2** (identification H).



- First push the front height adjustment under the mounts **1** then push it into the locking mechanism **2** until it engages.

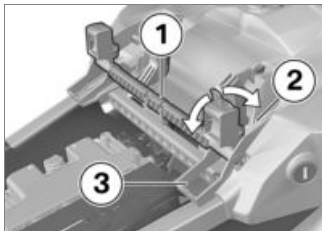

- Set the driver's seat height and inclination (➡ 92).

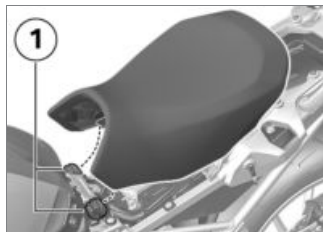

- To set the low seat position, swing the rear height adjustment **1** into position **3** (identification L).
- To set the high seat position, swing the rear height adjustment into position **1 2** (identification H).

If the seat angle needs to be adjusted:

- Position the front and rear height adjustment differently.

- Insert the rider's seat into the fixtures **1** on the left and right and lean carefully on the motorcycle.
- Push the rider's seat forwards slightly by applying pressure at the rear and then push it down with force until the locking mechanism engages.

Installing front seat

- Removing rear seat (➡ 91).

TFT display

General instructions.....	96
Principle	97
Pure Ride view.....	103
General settings	105
Bluetooth	106
My Vehicle.....	110
Navigation	113
Media.....	115
Phone	115
Switch GPS synchronisation on or off	116
Display software version	116
Display licence information.....	116

General instructions

Warnings



WARNING

Using a smartphone during the journey or while the engine is running

Risk of accident

- Always observe the relevant road traffic regulations.
- Do not use the smartphone during the journey (apart from applications that do not require operation, e.g. making telephone calls with the hands-free system).◀



WARNING

Distraction from the road and loss of control

Operating the integrated information system and communication devices while driving results in a risk of accident

- Operate those systems or devices only when the traffic situation allows for it.
- If necessary, stop and operate the systems or devices when stationary.◀

Connectivity functions

Connectivity functions include media, telephony and navigation.

Connectivity functions can be used if the TFT display is connected to a mobile end device and a helmet (📞▶ 107).

For more information on the Connectivity functions go to **bmw-motorrad.com/connectivity**



NOTICE

If the fuel tank is between the mobile end device and the TFT display, the Bluetooth connection may be restricted. BMW Motorrad recommends

storing the end device above the fuel tank (e.g. in your jacket pocket).◀



NOTICE

Depending on the mobile end device, the scope of the Connectivity functions may be restricted.◀

BMW Motorrad Connected App

The BMW Motorrad Connected App contains usage and vehicle information. For some functions, such as navigation, the app must be installed on the mobile end device and connected to the TFT display. The app is used to start route guidance and adjust the navigation.

NOTICE

On some mobile end devices, e.g. those with iOS operating systems, the BMW Motorrad Connected App must be opened before use. ◀

Actuality

The TFT display may be updated after the publication date. Because of this, your motorcycle may differ from the information supplied in the Rider's Manual. For up-to-date information go to bmw-motorrad.com

Principle Controls

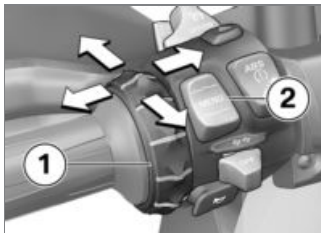

All contents of the display are operated using the multi-controller **1** and the MENU **2** rocker button.

Depending on the context, the following functions are possible.

Multi-controller functions

Turn the multi-controller upwards:

- Move the cursor upwards in lists.
- Adjust settings.
- Increase volume.

Turn the multi-controller downwards:

- Move the cursor downwards in lists.
- Adjust settings.
- Decrease volume.

Tilt the multi-controller to the left:

- Activate the function in accordance with the operation feedback.
- Activate the function to the left or back.
- Go back to the View menu after settings.
- In the View menu, change up a level.
- In the My Vehicle menu: advance one menu screen.

Tilt the multi-controller to the right:

- Activate the function in accordance with the operation feedback.

- Confirm selection.
- Confirm settings.
- Advance a menu step.
- Scroll to the right in lists.
- In the My Vehicle menu: advance one menu screen.

MENU rocker button functions

NOTICE

Instructions given by the navigation system are displayed in a dialogue box if the **Navigation** menu has not been called up. Operation of the MENU rocker button is temporarily restricted. ◀

Briefly push MENU up:

- In the View menu, change up a level.
- In the Pure Ride view: change the display for rider info status line.

Press and hold MENU up:

- In the View menu: call up Pure Ride view.
- In Pure Ride view: change operating focus to the Navigator.

Briefly push MENU down:

- Change down a level.
- No function if the lowest hierarchical level has been reached.

Hold MENU down:

- Change back to the last menu after a previous menu change by holding up the MENU rocker button.

Operating instructions in the main menu

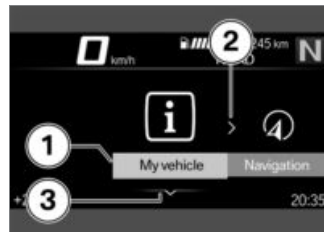

Operating instructions show whether interactions are possible, and which ones.

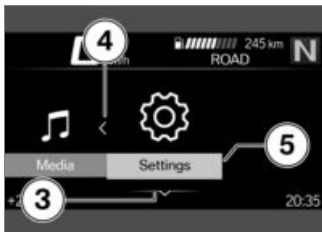

What the operating instructions mean:

- Operating instruction **1**: the left end has been reached.
- Operating instruction **2**: it is possible to scroll to the right.
- Operating instruction **3**: it is possible to scroll down.
- Operating instruction **4**: it is possible to scroll to the left.
- Operating instruction **5**: the right end has been reached.

Operating instructions in submenus

In addition to the operating instructions in the main menu, there are further operating instructions in submenus.

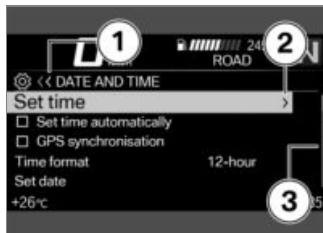

What the operating instructions mean:

- Operating instruction **1**: the current display is in a hierarchical menu. One symbol represents a submenu level. Two symbols represent two or more submenu level. The colour of the symbol changes depending

- on whether it is possible to go back to the top.
- Operating instruction **2**: another submenu can be called up.
- Operating instruction **3**: there are more items than can be displayed.

Display Pure Ride view

- Press and hold MENU rocker button up.

Switching functions on and off



Some menu items have a check box in front of them. The check box shows whether the function is on or off. Action symbols after the menu items show what will be switched by tilting the multi-controller briefly to the right.

Examples for switching on and off:

- Symbol **1** shows that the function is switched on.
- Symbol **2** shows that the function is switched off.

- Symbol **3** shows that the function can be switched off.
- Symbol **4** shows that the function can be switched on.

Call up the menu

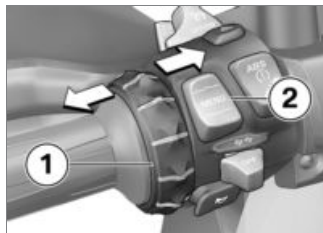

- Display Pure Ride view (100 ▶ 99).
- Briefly push button **2** down.

The following menus can be called up:

- My Vehicle
- Navigation
- Media
- Telephone
- Settings

- Repeatedly press the multi-controller **1** briefly to the right until the desired menu item is highlighted.
- Briefly push button **2** down.



NOTICE

The Settings menu can only be called up when the vehicle is stationary. ◀

Move the cursor in lists

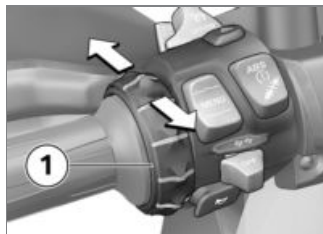

- Call up the menu (100 ▶ 100).
- To move the cursor down in lists, turn the multi-controller **1**

down until the desired entry is highlighted.

- To move the cursor up in lists, turn the multi-controller **1** up until the desired entry is highlighted.

Confirm selection.



- Select the desired entry.
- Briefly press the multi-controller **1** to the right.

Call up the last menu used

- In Pure Ride view: press and hold the MENU rocker button.

- » The last menu used is called up. The last entry highlighted is selected.

Change of operating focus

- with preparation for navigation system^{OE}

If the Navigator is connected, it is possible to switch between operation of the Navigator and the TFT display.

Change the operating focus

- with preparation for navigation system^{OE}

- Securing navigation device (► 204).
- Display Pure Ride view (► 99).
- Press and hold MENU rocker button up.
 - » Operating focus switches to the Navigator or TFT display. The active device is marked on the left-hand side of the top

status line. Operating actions relate to the active device until the operating focus is changed again.

- » Operating navigation system (► 206)

System status displays

The system status is displayed in the lower area of the menu if a function is switched on or off.

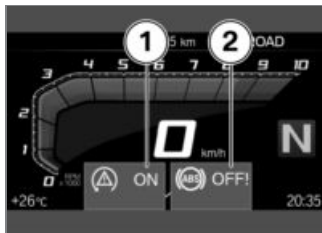

Examples of what the system statuses mean:

- System status **1**: ASC/DTC function is switched on.

- System status **2**: ABS function is switched off.

Switch display for rider info status line

Requirement

The vehicle is at a standstill. The Pure Ride view is displayed.

- Switching on ignition (➡ 56).
 - » All the information necessary for riding on public roads is presented in the TFT display by the on-board computer. The information can be displayed on the top status line.
 - with tyre pressure control (RDC)^{OE}
 - » Information from the tyre pressure control can also be displayed.◀
- Select content of the rider info status line (➡ 103).



- Press and hold button **1** to display the Pure Ride view.
- Briefly press button **1** to select the value in the top status line **2**.

The following values can be displayed:

- Odometer *Total*
- Trip distance 1 *Current*
- Trip distance 2 *Current*
- Current consumption *Consumption*



Average consumption 1



Average consumption 2



Driving time 1



Driving time 2



Inactive period 1



Inactive period 2



Average speed 1



Average speed 2



Tyre pressure



Fuel gauge.



Range

Select content of the rider info status line

- Call up menu *Settings, Display, Status line* content.
- Switch on the desired displays.
 - » It is possible to switch between the selected displays in the status line. If no displays are selected, only the range will be displayed.

Adjust settings



- Select and confirm the desired settings menu.

- Turn the multi-controller **1** downwards until the desired setting is highlighted.
- If there are operating instructions, tilt the multi-controller **1** to the right.
- If there are no operating instructions, tilt the multi-controller **1** to the left.
 - » The setting is saved.

Switch Speed Limit Info on or off

Requirement

Vehicle is connected to the Navigator or a compatible mobile end device. The BMW Motorrad Connected App is installed on the mobile end device.

- *Speed Limit Info* displays the maximum speed currently permitted.
- Call up menu *Settings, Display*.

- Switch *Speed Limit Info* on or off.

Pure Ride view

Engine speed display

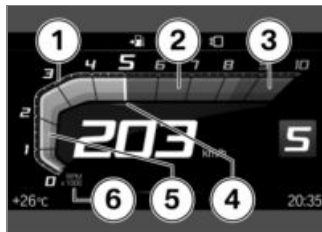

- 1 Scale
- 2 Lower engine speed range
- 3 Upper/red engine speed range
- 4 Needle
- 5 Trailing indicator
- 6 Engine speed display unit: 1000 revolutions per minute



NOTICE

Depending on the oil temperature, the red engine speed range changes:

The colder the engine, the lower the engine speed at which the red engine speed range starts.

The warmer the engine, the higher the engine speed at which the red engine speed range starts.

Once the operating temperature has been reached, the red engine speed range display does not change any more.

If the engine speed is too high, the entire scale flashes.

The recommended upshifts are also adjusted dynamically. ◀

Range



The range readout **1** indicates how far you can ride with the fuel remaining in the tank. This distance is calculated on the basis of average consumption and the quantity of fuel on board.

- When the motorcycle is propped on its side stand the slight angle of inclination means that the sensor cannot register the fuel level correctly. This is the reason why the range is recalculated only when the side stand is in the retracted position.

- The range is shown together with a warning once the fuel reserve has been reached.
- After a refuelling stop, range is recalculated if the amount of fuel in the tank is greater than the reserve quantity.
- The calculated range is only an approximate figure.

Recommendation to upshift



The upshift recommendation **1** signals the economically best point in time for upshift.

General settings

Adjust the volume

- Connect rider's and passenger's helmet (▶▶▶ 108).
- Increase volume: turn the multi-controller upwards.
- Decrease volume: turn the multi-controller downwards.
- Mute: turn the multi-controller all the way down.

Setting the date

- Switching on ignition (▶▶▶ 56).
- Call up menu Settings, System settings, Date and time, Set date.
- Adjust Day, Month and Year.
- Confirm setting.

Set date format

- Call up menu Settings, System settings, Date and time, Date format.
- Select the desired setting.
- Confirm setting.

Setting the clock

- Switching on ignition (▶▶▶ 56).



Adjusting the clock while riding

Risk of accident

- Set the clock only when the motorcycle is stationary.◀
- Call up menu Settings, System settings, Date and time, Set time.
- Adjust Hour and Minute.

Switch automatic time setting on or off



Depending on the features, the time is updated automatically.◀



Adjusting the clock while riding

Risk of accident

- Set the clock only when the motorcycle is stationary.◀
- Call up menu Settings, System settings, Date and time.
- Switch Set time automatically on or off.

Set time format



Adjusting the clock while riding

Risk of accident

- Set the clock only when the motorcycle is stationary.◀
- Call up menu Settings, System settings, Date and time, Time format.
- Select the desired setting.
- Confirm setting.

Set units of measurement

- Call up menu `Settings, System settings, Units`.

The following units of measurement can be set:

- Distance covered
- Pressure
- Temperature
- Speed
- Consumption

Set language

- Call up menu `Settings, System settings, Language`.

The following languages can be set:

- Chinese
- German
- English
- Spanish
- French
- Italian
- Dutch
- Portuguese
- Russian

– Ukrainian

Adjusting brightness

- Call up the `Settings, Display, Brightness` menu.
- Adjust display brightness .

Reset all settings

- All the settings in the `Settings` menu can be reset to the factory settings.
- Call up the `Settings` menu.
- Select `Reset all` and confirm.

The settings in the following menus are reset:

- `Vehicle settings`
- `System settings`
- `Connections`
- `Display`
- `Information`

» Existing Bluetooth connections are not deleted.

Bluetooth

Short-range wireless technology

The Bluetooth function might not be available in certain countries.

Bluetooth is a short-range wireless technology. Bluetooth devices are short-range devices transmitting on the license-free ISM band (Industrial, Scientific, Medical) between 2.402 GHz and 2.480 GHz. They can be operated anywhere in the world without a licence being required. Although Bluetooth is designed to establish and sustain robust connections over short distances, as with every other wireless technology disruptions are possible. Interference can affect connections or connections can sometimes fail. Particularly when multiple devices operate in a Bluetooth network, with wireless technology of this nature it is

not possible to ensure fault-free communications in every situation.

Possible sources of interference:

- interference zones due to transmission masts and similar.
- devices with non-compliant Bluetooth implementations
- proximity of other Bluetooth-compatible devices

Pairing

Two Bluetooth devices must detect each other before they can create a connection with each other. This process of mutual recognition is known as pairing. When two devices have paired they remember each other, so the pairing process is conducted only once, on initial contact.

NOTICE

On some mobile end devices, e.g. those with iOS operating systems, the BMW Motorrad Connected App must be opened before use. ◀

During the pairing process, the TFT display searches for other Bluetooth-compatible devices within its reception range. The conditions that have to be satisfied before the audio system can recognise another device are as follows:

- The Bluetooth function of the device must be activated
- The device must be "visible" to others
- The device must support the A2DP profile
- Other Bluetooth-compatible devices must be OFF (e.g.

mobile phones and navigation systems).

Please consult the operating instructions for your communication system.

Pairing

- Call up the **Settings, Connections** menu.
 - » In the **CONNECTIONS** menu, Bluetooth connections can be established, managed and deleted. The following Bluetooth connections are displayed:
 - Mobile device
 - Rider's helmet
 - Passenger helm.
- The connection status for mobile end devices is displayed.

Connect mobile end device

- Pairing (▬▶ 107).
- Activate the mobile end device's Bluetooth function

(see mobile end device's operating instructions).

- Select `Mobile device` and confirm.
- Select `PAIR NEW MOBILE DEVICE` and confirm.

Mobile end devices are being searched for.

 The Bluetooth symbol flashes in the bottom status line during pairing.

Mobile end devices found are displayed.

- Select and confirm mobile end device.
- Follow the instructions on the mobile end device.
- Confirm that the code matches.
- » The connection is established and the connection status updated.
- » If the connection is not established, consult the

troubleshooting chart in the section entitled "Technical data". (▶▶▶ 216)

- » Depending on the mobile end device, telephone data is transferred to the vehicle automatically.
- » Telephone data (▶▶▶ 116)
- » If the telephone book is not displayed, consult the troubleshooting chart in the section entitled "Technical data". (▶▶▶ 217)
- » If the Bluetooth connection is not working as expected, consult the troubleshooting chart in the section entitled "Technical data". (▶▶▶ 217)

Connect rider's and passenger's helmet

- Pairing (▶▶▶ 107).
- Select `Rider's helmet` or `Passenger helm.` and confirm.

- Make the helmet's communication system visible
- Select `PAIR NEW RIDER'S HELMET` or `PAIR NEW PASSENGER HELMET` and confirm.

Helmets are searched for.

 The Bluetooth symbol flashes in the bottom status line during pairing.

Helmets found are displayed.

- Select and confirm helmet.
- » The connection is established and the connection status updated.
- » If the connection is not established, consult the troubleshooting chart in the section entitled "Technical data". (▶▶▶ 216)
- » If the Bluetooth connection is not working as expected, consult the troubleshooting chart in the section entitled "Technical data". (▶▶▶ 217)

Delete connections

- Call up the Settings, Connections menu.
- Select Delete connections.
- To delete an individual connection, select the connection and confirm.
- To delete all connections, select Delete all connections and confirm.

My Vehicle

Start screen

- 1 Check control display
Mode of presentation (►► 25)
- 2 Coolant temperature (►► 40)
- 3 Range (►► 104)
- 4 Total distance travelled
- 5 Service-due indicator (►► 53)
- 6 Rear tyre pressure (►► 43)
- 7 On-board voltage (►► 186)
- 8 Engine oil level (►► 40)
- 9 Front tyre pressure (►► 43)



Operating instructions

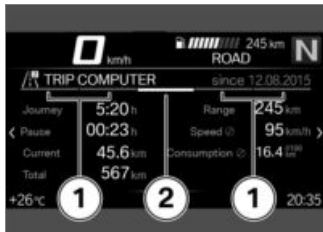

- Operating instruction **1**: tabs which show how far to the left or right can be scrolled.
- Operating instruction **2**: tab which shows the position of the current menu screen.

Scroll through menu screens

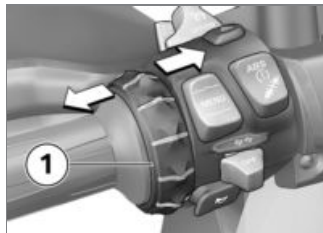

- Call up the *My Vehicle* menu.
- To scroll to the right, briefly press multi-controller **1** to the right.
- To scroll to the left, briefly press multi-controller **1** to the left.

The *My Vehicle* menu contains the following screens:

- *MY VEHICLE*
- Check control messages (if any)
- *ON-BOARD COMPUTER*
- *TRIP COMPUTER*

- with tyre pressure control (RDC)^{OE}
- *TYRE PRESSURE*◀
- *SERVICE REQUIREMENTS*
- For more information on tyre pressure and check control messages, see the "Displays" section.



NOTICE

Check control messages are attached dynamically to the *My Vehicle* menu screen as additional tabs.◀

On-board computer and journey computer

The *ON-BOARD COMPUTER* and *TRIP COMPUTER* menu screens display vehicle and journey data, such as average values.

Service requirements

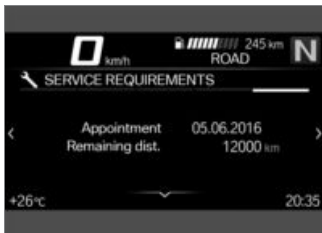

If the time remaining to the next service is less than a month or if the next service is due within 700 miles (1000 km), a white CC message is displayed.

Navigation

Warnings

WARNING

Using a smartphone during the journey or while the engine is running

Risk of accident

- Always observe the relevant road traffic regulations.
- Do not use the smartphone during the journey (apart from applications that do not require operation, e.g. making telephone calls with the hands-free system).◀

WARNING

Distraction from the road and loss of control

Operating the integrated information system and communication devices while driving results in a risk of accident

- Operate those systems or devices only when the traffic situation allows for it.
- If necessary, stop and operate the systems or devices when stationary.◀

Precondition

The vehicle is connected to a compatible mobile end device.

Precondition

The BMW Motorrad Connected App is installed on the connected mobile end device.

NOTICE

On some mobile end devices, e.g. those with iOS operating systems, the BMW Motorrad Connected App must be opened before use.◀

Enter destination address

- Connect mobile end device (➡ 107).
- Call up the BMW Motorrad Connected App and start the route guidance.
- Call up the `Navigation` menu in the TFT display.
 - » Active route guidance is displayed.
 - » If the active route guidance is not displayed, consult the troubleshooting chart in the section entitled "Technical data". (➡ 217)

Select destination from recent destinations

- Call up the `Navigation, Recent destinations` menu.
- Select and confirm destination.
- Select `Start route guidance`.

Select destination from favourites

- The FAVOURITES menu displays all destinations which have been saved as favourites in the BMW Motorrad Connected app. No new favourites can be added to the TFT display.
- Call up the Navigation, Favourites menu.
- Select and confirm destination.
- Select Start guidance.

Enter special destinations

- Special destinations, such as points of interest, can be displayed on the map.
- Call up the Navigation, POIs menu.

The following locations can be selected:

- At current location
- At destination
- Along the route

- Select where the special destinations should be looked for. e.g. the following special destination can be selected:
 - Filling station
- Select and confirm the special destination.
- Select Start route guidance and confirm.

Set route criteria

- Call up the Navigation, Route criteria menu.
- The following criteria can be selected:
- Route type
 - Avoid
 - Select desired Route type.
 - Switch desired Avoid on or off.

The number of avoidances activated is displayed in brackets.

End route guidance

- Call up the Navigation, Active route guidance menu.
- Select End route guidance and confirm.

Switch spoken instructions on or off

- Connect rider's and passenger's helmet (☞ 108).
- The navigation can be read out by a computer voice. For this purpose, Spoken instruction must be switched on.
- Call up the Navigation, Active route guidance menu.
- Switch Spoken instruction on or off.

Repeat last spoken instruction

- Call up the Navigation, Active route guidance menu.

- Select **Current instruction** and confirm.

Media

Precondition

The vehicle is connected to a compatible mobile end device and helmet.

Control music playback

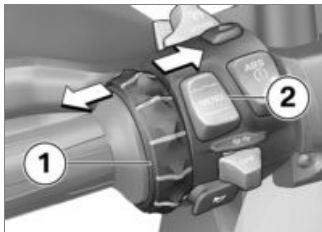

- Call up the **Media** menu.

NOTICE

BMW Motorrad recommends setting the volume on the mobile

end device to maximum before setting off. ◀

- Adjust the volume (▬▶ 105).
- Next track: briefly tilt multi-controller **1** to the right.
- Last track or start of the current track: briefly tilt multi-controller **1** to the left.
- Fast forward: hold multi-controller **1** to the right.
- Rewind: hold multi-controller **1** to the left.
- Call up the context menu: press bottom part of button **2**.

NOTICE

Depending on the mobile end device, the scope of the Connectivity functions may be restricted. ◀

- » The following functions can be used in the context menu:
 - Start playback or Pause playback.

- Select the **Now playing**, **All artists**, **All albums** or **All tracks** categories for search and playback.
- Select **Playlists**.

You can make the following adjustments in the **Audio options** submenu:

- Switch **Shuffle** on or off.
- Select **Repeat**: **Off**, **One** (current song) or **All**.

Phone

Precondition

The vehicle is connected to a compatible mobile end device and helmet.

Telephone calls



- Call up the Telephone menu.
- Accept call: tilt multi-controller **1** to the right.
- Reject call: tilt multi-controller **1** to the left.
- End the call: tilt multi-controller **1** to the left.

Muting

During active phone calls, the microphone in the helmet can be muted.

Phone calls with multiple participants

During one phone call, a second call can be accepted. The first phone call is put on hold. The number of active telephone calls is shown in the Telephone menu. It is possible to switch between two phone calls.

Telephone data

Depending on the mobile end device, telephone data is transmitted to the vehicle automatically once pairing is complete (►► 107).

Phone book: list of contacts saved on the mobile end device

Call list: list of calls with the mobile end device

Favourites: list of favourites saved on the mobile end device

Switch GPS synchronisation on or off

- Call up menu Settings, System settings, Date and time.
- Switch GPS synchronisation on or off.

Display software version

- Call up menu Settings, Information, Software version.

Display licence information

- Call up the Settings, Information, Licences menu.

Adjustment

Mirrors	118
Headlight	118
Windscreen	119
Clutch	120
Brakes	120
Handlebars	121
Spring preload	121
Damping	122

Mirrors

Adjusting mirrors



- Turn the mirror to the correct position.

Adjusting mirror arm

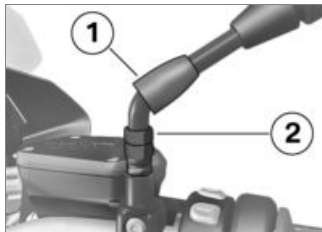

- Push protective cap **1** up over the threaded fastener on the mirror arm.
- Slacken nut **2**.
- Turn the mirror arm to the appropriate position.
- Tighten the nut to the specified tightening torque, while holding the mirror arm in place.



Mirror (locknut) to adapter

22 Nm (Left-hand thread)

- Push protective cap **1** over the threaded fastener.

Headlight

Headlight beam throw and spring preload

Headlight beam throw is generally kept constant when spring preload is adjusted to suit load. Spring preload adjustment might not suffice only if the motorcycle is very heavily loaded. Under these circumstances, headlight beam throw has to be adjusted to suit the weight carried by the motorcycle.



NOTICE

If there are doubts about the correct headlight beam throw, have the setting checked by a specialist workshop, preferably an authorised BMW Motorrad dealer. ◀

Adjusting headlight beam throw



If, for a high load, the adjustment of the spring pre-load is no longer sufficient not to dazzle oncoming traffic:

- Turn adjuster knob **1** counter-clockwise in order to lower the headlight beam again.

When the motorcycle is again ridden with a lower load:

- Have the basic settings of the headlight restored by a specialist workshop, best of all by a BMW Motorrad dealer.

– with LED headlight^{OE}

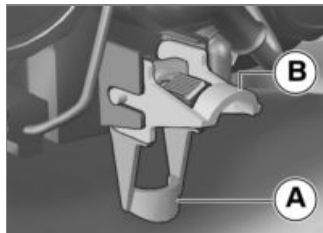

- The headlight beam-throw is adjusted via an engage pivot lever.
- **A** Neutral position
- **B** Position for heavy load◀

Windscreen

Adjusting windscreen

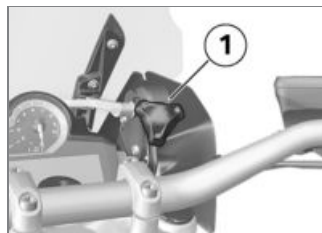

! WARNING

Adjusting the windscreen while riding

Risk of falling

- Do not attempt to adjust the windscreen unless the motorcycle is at a standstill.◀
- Turn knob **1** clockwise to lower the windscreen.
- Turn knob **1** counter-clockwise to raise the windscreen.

Clutch

Adjusting the clutch lever



WARNING

Adjusting the clutch lever while riding

Risk of accident

- Do not attempt to adjust the clutch lever unless the motorcycle is at a standstill. ◀

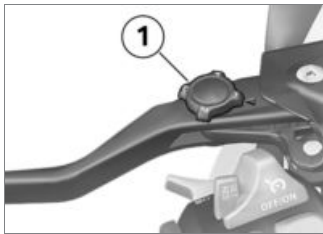

- Turn knob **1** to the desired position.



NOTICE

The adjuster is easier to turn if you push the clutch lever forward. ◀

- » Four settings are possible:
- Position 1: smallest span between handlebar grip and clutch lever
 - Position 4: largest span between handlebar grip and clutch lever

Brakes

Adjusting the front brake lever



WARNING

Adjusting the brake lever while riding

Risk of accident

- Do not attempt to adjust the brake lever unless the motorcycle is at a standstill. ◀

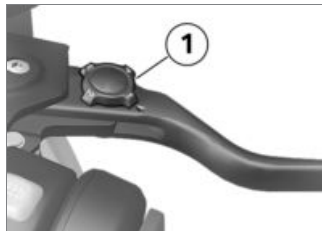

- Turn knob **1** to the desired position.



NOTICE

The adjuster is easier to turn if you push the brake lever forward. ◀

- » Four settings are possible:
- Position 1: smallest span between handlebar grip and brake lever
 - Position 4: largest span between handlebar grip and brake lever

Handlebars

Adjustable handlebars

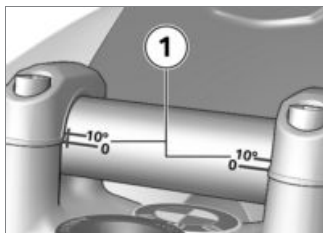

The angle of the handlebars can be adjusted within the marked areas **1**.

Allow a specialist workshop, preferably an authorised BMW Motorrad dealer to adjust the handlebars.

Spring preload

– without Dynamic ESA^{OE}

Adjustment

It is essential to set the spring preload of the rear suspension to suit the load carried by the motorcycle. Increase the spring preload when the vehicle is heavily loaded and reduce the spring preload accordingly when the vehicle is lightly loaded.

Adjusting spring preload for rear wheel

WARNING

Adjusting spring preload while riding.

Risk of accident

- Do not attempt to adjust spring preload unless the motorcycle is at a standstill. ◀
- Place the motorcycle on its stand on firm, even ground.



WARNING

Spring preload setting and spring-strut damping setting not matched.

Impaired handling.

- Adjust spring-strut damping to suit spring preload. ◀
- To increase the spring preload, turn the adjuster knob **1** in the direction indicated by the HIGH arrow.
- To reduce the spring preload, turn the adjuster knob **1** in the direction indicated by the LOW arrow.



Basic setting of spring preload, rear

Turn the knob as far as it will go in the LOW direction. (One-up without luggage)

Turn the adjuster knob as far as it will go in the LOW direction, then 15 turns in the HIGH direction. (One-up with luggage)

Turn the adjuster knob as far as it will go in the LOW direction, then 30 turns in the HIGH direction. (Two-up with luggage)

Damping

– without Dynamic ESA^{OE}

Setting

Damping must be adapted to suit the surface on which the motorcycle is ridden and to suit spring preload.

- An uneven surface requires softer damping than a smooth surface.
- An increase in spring preload requires firmer damping, a reduction in spring preload requires softer damping.

Adjusting the damping characteristic for rear wheel

- Place the motorcycle on its stand on firm, even ground.
- Set the damping from the left-hand vehicle side.

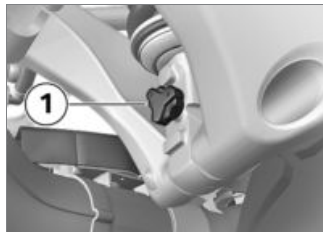

- Turn the adjusting screw **1** clockwise to harden the damping action.
- Turn the adjusting screw **1** anticlockwise to soften the damping action.



Basic setting of rear-suspension damping characteristic

Turn the adjuster knob as far as it will go in the clockwise direction, then back it off 8 clicks in the counter-clockwise direction. (One-up without luggage)



Basic setting of rear-suspension damping characteristic

Turn the adjuster knob as far as it will go in the clockwise direction, then back it off 2 clicks in the counter-clockwise direction. (One-up with luggage)

Turn the adjuster knob as far as it will go in the clockwise direction, then back it off 2 clicks in the counter-clockwise direction. (Two-up with luggage)

Riding

Safety instructions	126
Comply with checklist.....	129
Always before riding off	129
Every 3rd refuelling stop	129
Starting	129
Running in	133
Off-roading	133
Shifting gear	135
Brakes	136
Parking your motorcycle	138
Refuelling	138
Securing motorcycle for transportation	142

Safety instructions

Rider's equipment

Do not ride without the correct clothing! Always wear:

- Helmet
- Motorcycling jacket and trousers
- Gloves
- Boots

This applies even to short journeys, and to every season of the year. Your authorised BMW Motorrad dealer will be glad to advise you on the correct clothing for every purpose.

Restricted angle of heel

- with lowered suspension ^{OE}

A motorcycle with lowered suspension has less ground clearance and cannot corner at angles of heel as extreme as those achievable by a

counterpart motorcycle with standard-height suspension.



WARNING

When a motorcycle with lowered suspension is cornering, certain components can come into contact with the surface at a bank angle less than that to which the rider is accustomed.

Risk of falling

- Carefully try out the limits of the motorcycle's bank angle and adapt your style of riding accordingly. ◀

Test your motorcycle's angle of heel in situations that do not involve risk. When riding over kerbs and similar obstacles, bear in mind that your motorcycle's ground clearance is limited.

Lowering the motorcycle's suspension shortens suspension travel (see the section entitled "Technical Data"). Ride comfort might be restricted as a result. Be sure to adjust spring preload accordingly, particularly for riding two-up.

Loading



WARNING

Handling adversely affected by overloading and imbalanced loads

Risk of falling

- Do not exceed the permissible gross weight and be sure to comply with the instructions on loading. ◀
- Adjusting spring preload setting and damping to the total weight.

- with cases^{OA}
 - Ensure that the case volumes on the left and right are equal.
 - Make sure that the weight is uniformly distributed between right and left.
 - Pack heavy items at the bottom and toward the inboard side.
 - Note the maximum permissible payload and the speed limit for riding with cases fitted, as stated on the label inside the case (see also the section entitled "Accessories").<
- with topcase^{OA}
 - Note the maximum permissible payload and the speed limit for riding with topcase fitted, as stated on the label inside the case (see also the section entitled "Accessories").<

- with tank bag^{OA}
 - Note the maximum permissible payload of the tank rucksack.

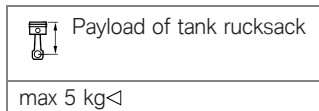

Speed

If you ride at high speed, always bear in mind that various boundary conditions can adversely affect the handling of your motorcycle:

- Settings of the spring-strut and shock-absorber system
- Imbalanced load
- Loose clothing
- Insufficient tyre pressure
- Poor tyre tread
- Etc.

Maximum speed with knobbly tyres or winter tyres



Maximum speed of the motorcycle is higher than the permissible maximum rated speed of the tyres

Risk of accident due to tyre damage at high speed

- Comply with the tyre-specific speed restrictions.<

Always bear the maximum permissible speed of the tyres in mind when riding a motorcycle fitted with knobbly tyres or winter tyres.

Affix a label stating the maximum permissible speed to the instrument panel in the rider's field of vision.

Risk of poisoning

Exhaust fumes contain carbon monoxide, which is colourless and odourless but highly toxic.

WARNING

Exhaust gases adversely affecting health

Risk of asphyxiation

- Do not inhale exhaust fumes.
- Do not run the engine in an enclosed space.◀

Risk of burn injury

CAUTION

Engine and exhaust system become very hot when the vehicle is in use

Risk of burn injury

- When you park the vehicle make sure that no-one and no objects can come into contact with the hot engine and exhaust system.◀

Catalytic converter

If misfiring causes unburned fuel to enter the catalytic converter, there is a danger of overheating and damage.

The following guidelines must be observed:

- Do not run the fuel tank dry.
- Do not attempt to start or run the engine with a spark-plug cap disconnected.
- Stop the engine immediately if it misfires.
- Use only unleaded fuel.
- Comply with all specified maintenance intervals.

ATTENTION

Unburned fuel in catalytic converter

Damage to catalytic converter

- Note the points listed for protection of the catalytic converter.◀

Risk of overheating

ATTENTION

Engine running for prolonged period with vehicle at standstill

Overheating due to insufficient cooling; in extreme cases vehicle fire

- Do not allow the engine to idle unnecessarily.
- Ride away immediately after starting the engine.◀

Tampering

ATTENTION

Tampering with the motorcycle (e.g. engine management ECU, throttle valves, clutch)

Damage to the affected parts, failure of safety-relevant functions, voiding of warranty

- Do not tamper with the vehicle in any way that could result in tuned performance. ◀

Comply with checklist

- At regular intervals, use the checklist below to check your motorcycle.

Always before riding off

- Check operation of the brake system.
- Check operation of the lights and signalling equipment.
- Checking clutch function (▣▣▣ 168).
- Checking tyre tread depth (▣▣▣ 170).
- Checking tyre pressure (▣▣▣ 170).
- Check that cases and luggage are securely held in place.

Every 3rd refuelling stop

- without Dynamic ESA^{OE}
 - Adjuster for spring preload, rear (▣▣▣ 121).
 - Adjusting the damping characteristic for rear wheel (▣▣▣ 122). ◀
- with Dynamic ESA^{OE}
 - Adjusting the chassis and suspension (▣▣▣ 76). ◀
 - Checking engine oil level (▣▣▣ 162).
 - Checking front brake pad thickness (▣▣▣ 164).
 - Check rear brake pad thickness (▣▣▣ 165).
 - Checking brake-fluid level, front brakes (▣▣▣ 166).
 - Checking the brake-fluid level, rear brakes (▣▣▣ 167).
 - Check coolant level (▣▣▣ 168).

Starting

Starting the engine

- Switch on the ignition.
 - » Pre-Ride-Check is performed. (▣▣▣ 130)
 - » ABS self-diagnosis is in progress. (▣▣▣ 130)
- without riding modes Pro^{OE}
 - » ASC self-diagnosis is performed. (▣▣▣ 131) ◀
- with riding modes Pro^{OE}
 - » DTC self-diagnosis is in progress. (▣▣▣ 132) ◀
- Select neutral or, if a gear is engaged, pull the clutch lever.



NOTICE

You cannot start the motorcycle with the side stand extended and a gear engaged. The engine will switch itself off if you start it with the gearbox in neutral and then engage a gear before retracting the side stand. ◀

- For a cold engine start and low temperatures: pull clutch.



- Press the starter button **1**.
 - » The engine starts.
 - » If the engine refuses to start, consult the troubleshooting chart in the section entitled "Technical data". (➡ 216)
- Recharge the battery before you start the engine, or use jump leads and a donor battery to start.
- Charge battery when connected (➡ 186).
 - Jump-starting (➡ 184).



NOTICE

The start attempt is automatically interrupted if battery voltage is too low. ◀

Pre-Ride-Check

When the ignition is switched on, the instrument cluster runs a test of the telltale lights and the warning lights. This test is known as the "Pre-Ride-Check". The test is aborted if you start the engine before it completes.

Phase 1

All telltale and warning lights are switched on. After a longer vehicle standstill period, an animation is displayed when the system starts up.

Phase 2

The 'General' warning light changes from red to yellow.

Phase 3

All the telltale and warning lights are switched on in the initial phase and switched off in reverse sequence.

The malfunction indicator lamp only goes out after 15 seconds.

If one of the indicator and warning lights did not switch on:

- Have the fault rectified as quickly as possible by a specialist workshop, preferably an authorised BMW Motorrad dealer.

ABS self-diagnosis

BMW Motorrad Integral ABS performs self-diagnosis to ensure its operability. Self-diagnosis starts automatically when you switch on the ignition.

Phase 1

- » Test of the diagnosis-compatible system components with the vehicle at a standstill.



ABS telltale and warning light flashes.

Phase 2

- » Test of the wheel-speed sensors as the vehicle pulls away from rest.



ABS telltale and warning light flashes.

ABS self-diagnosis completed

- » The ABS indicator and warning light goes out.



ABS self-diagnosis not completed

The ABS function is not available, because self-diagnosis did not complete. (The motorcycle has to reach a defined minimum speed for the wheel speed sensors to be checked: 5 km/h)

If an indicator showing an ABS fault appears when ABS self-diagnosis completes:

- You can continue to ride. Bear in mind that neither the ABS function nor the integral braking function is available.
- Have the fault rectified as quickly as possible by a specialist workshop, preferably an authorised BMW Motorrad dealer.

ASC self-diagnosis

– without riding modes Pro^{OE}

BMW Motorrad ASC performs self-diagnosis to ensure its operability. Self-diagnosis is performed automatically when you switch on the ignition.

Phase 1

- » Test of the diagnosable system components with the vehicle at a standstill.



ASC telltale and warning light slow-flashes.

Phase 2

- » Test of the diagnosis-compatible system components while the motorcycle is on the move.



ASC telltale and warning light slow-flashes.

ASC self-diagnosis completed

- » The ASC telltale and warning light goes out.
- Check all the indicator and warning lights.



ASC self-diagnosis not completed

The ASC function is not available, because self-diagnosis did not complete. (The motorcycle has to reach a defined minimum speed for the wheel sensors to be checked: min 5 km/h)

If an indicator showing an ASC fault appears when ASC self-diagnosis completes:

- You can continue to ride. Bear in mind that the ASC function is not available.
- Have the fault rectified as quickly as possible by a specialist workshop, preferably

an authorised BMW Motorrad dealer.

DTC self-diagnosis

– with riding modes Pro^{OE}

BMW Motorrad DTC performs self-diagnosis to ensure its operability. Self-diagnosis is performed automatically when you switch on the ignition.

Phase 1

- » Test of the diagnosis-compatible system components with the vehicle at a standstill.



DTC indicator and warning light flashes slowly.

Phase 2

- » Pullaway test of the system components with diagnostic capability.



DTC indicator and warning light flashes slowly.

DTC self-diagnosis completed

- » The DTC symbol no longer shows.
- Check all the indicator and warning lights.



DTC self-diagnosis not completed

The DTC function is not available, because self-diagnosis did not complete. (The motorcycle has to reach a defined minimum speed with the engine running for the wheel-speed sensors to be checked: min 5 km/h)

If an indicator showing an DTC fault appears when DTC self-diagnosis completes:

- You can continue to ride. Bear in mind that the DTC function is not available or the functionality might be subject to certain restrictions.

- Have the fault rectified as quickly as possible by a specialist workshop, preferably an authorised BMW Motorrad dealer.

Running in Engine

- Until the first running-in check, vary the throttle opening and engine-speed range frequently; avoid riding at constant engine rpm for prolonged periods.
- Try to do most of your riding during this initial period on twisting, fairly hilly roads.
- Comply with the rpm limits for running in.

 Running-in speeds
<5000 min ⁻¹ (Odometer reading 0...1000 km)
no full throttle (Odometer reading 0...1000 km)

- Note the mileage after which the running-in check should be carried out.

 Mileage until the running-in check
500...1200 km

Brake pads

New brake pads have to bed down before they can achieve their optimum friction levels. You can compensate for this initial reduction in braking efficiency by exerting greater pressure on the levers.

WARNING

New brake pads

Longer stopping distance, risk of accident

- Apply the brakes in good time.◀

Tyres

New tyres have a smooth surface. This must be roughened by riding in a restrained manner at various heel angles until the tyres are run in. This running in procedure is essential if the tyres are to achieve maximum grip.

WARNING

New tyres losing grip on wet roads and at extreme bank angles

Risk of accident

- Ride carefully and avoid extremely sharp inclines.◀

Off-roading

For off-roading

Rims

ATTENTION

Off-roading more severe than riding on unsurfaced tracks

Damage to standard cast-aluminium rims

- Use the cross-spoked wheels available as optional extras for severe off-roading.◀

After off-roading

BMW Motorrad recommends checking the following after riding the motorcycle off-road:

Tyre pressure



WARNING

Lower tyre pressure for off-roading in operation on smooth roads

Risk of accident due to impaired driving characteristics.

- Always check that the tyre pressures are correct.◀

Brakes



WARNING

Driving on unpaved or dirt roads

Delayed braking efficiency due to soiled brake disks and brake pads.

- Brake early until the brakes are clean.◀



ATTENTION

Riding on unsurfaced or dirty roads

Increased brake pad wear

- Check the thickness of the brake pads more frequently and replace the brake pads in good time.◀

Spring preload and shock-absorber settings



WARNING

Changed values for spring preload and spring strut damping for off-roading

Impaired driving characteristics on paved roads

- Before leaving the off-road terrain, set the correct spring preload and shock absorption.◀

Rims

BMW Motorrad recommends checking the rims for damage after off-roading.

Air filter element



ATTENTION

Dirty air filter element

Engine damage

- If you ride in dusty terrain check the air filter element for

clogging at shorter intervals;
clean or replace as necessary. ◀

Operation in very dusty conditions (desert, steppes, or the like) necessitates the use of air filter elements specially designed for conditions of this nature.

Shifting gear

– with shift assistant Pro^{OE}

Shift assistant Pro

NOTICE

Whenever the Pro shift assistant shifts gears, cruise control is automatically disengaged for safety reasons. ◀

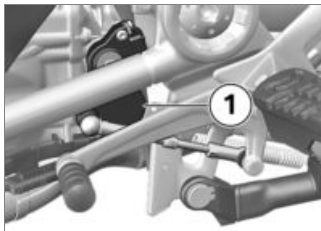

- Select the gears in the usual way by using the foot-operated gearshift lever.
 - » The shift assistant assists upshifts and downshifts without the rider having to pull the clutch or close the throttle.
- This is not an automatic-shift system.
- The rider is the most important part of the system and decides when to shift gears.
- Sensor **1** on the selector shaft registers the shift request and triggers shift assistance.
 - » When riding at a steady speed in a low gear at high engine

rpm, an attempt to shift gear without pulling the clutch can cause a severe load-change reaction.

- BMW Motorrad recommends disengaging the clutch for shifts in these circumstances.
- It is advisable to avoid using the Pro shift assistant at engine speeds close to the limits at which the governor cuts in to limit engine rpm.
 - » Shift assistance is not available in the following situations:
 - With clutch lever pulled.
 - Shift lever not in its initial position.
 - Upshifts with the throttle valve closed (coasting) and when slowing.
- After a gearshift, you must fully release the gearshift lever before another gearshift with the Pro shift assistant can take place.

- » See the section "Engineering details" for more information on the Pro shift assistant.
- with riding modes Pro^{OE}
- » Shift assistant Pro (▶▶ 156)◀

Brakes

How can stopping distance be minimised?

Each time the brakes are applied, a load distribution shift takes place with the load shifting forward from the rear to the front wheel. The sharper the motorcycle decelerates, the more load is shifted to the front wheel. The higher the wheel load, the more braking force can be transmitted without the wheel locking.

To optimise stopping distance, apply the front brakes rapidly and keep on increasing the force you apply to the brake lever. This makes the best possible use of the dynamic increase in load at

the front wheel. Remember to pull the clutch at the same time. In the "panic braking situations" that are trained so frequently braking force is applied as rapidly as possible and with the rider's full force applied to the brake levers; under these circumstances the dynamic shift in load distribution cannot keep pace with the increase in deceleration and the tyres cannot transmit the full braking force to the surface of the road.

BMW Motorrad Integral ABS prevents the front wheel from locking up.

Hazard braking

- with riding modes Pro^{OE}

If you brake sharply from a speed in excess of 50 km/h, the brake light flashes rapidly as an additional warning for road users behind you.

The hazard warning lights system switches on if you brake to below 15 km/h in this process. The hazard warning lights system automatically switches off again from a speed of 20 km/h.

Descending mountain passes



WARNING

Braking only with the rear brake on mountain descents

Brake fade, destruction of the brakes due to overheating

- Use both front and rear brakes, and make use of the engine's braking effect as well.◀

Wet and dirty brakes

Wetness and dirt on the brake discs and the brake pads diminish braking efficiency.

Delayed braking action or poor braking efficiency must be

reckoned with in the following situations:

- Riding in the rain or through puddles of water.
- After the vehicle has been washed.
- Riding on salted or gritted roads.
- After work has been carried on the brakes, due to traces of oil or grease.
- Riding on dirt-covered surfaces or off-road.

WARNING

Wetness and dirt result in diminished braking efficiency

Risk of accident

- Apply the brakes lightly while riding to remove wetness and dirt, or dismount and clean the brakes.
- Think ahead and brake in good time until full braking efficiency is restored.◀

ABS Pro

– with riding modes Pro^{OE}

Physical limits applicable to motorcycling

WARNING

Braking when cornering

Risk of crash despite ABS Pro

- Invariably, it remains the rider's responsibility to adapt riding style to riding conditions.
- Do not take risks that would negate the additional safety offered by this system.◀

ABS Pro is available in all riding modes except Enduro PRO.

Possibility of a fall not precluded

Although ABS Pro provides the rider with valuable assistance and constitutes a huge advance in safety for braking with the motorcycle banked for cornering, it

cannot under any circumstances be considered as redefining the physical limits that apply to motorcycling. It is still possible for these limits to be overshoot due to misjudgement or rider error. In extreme cases this can result in a crash.

Use on public roads

ABS Pro helps make the motorcycle even safer for riding on public roads. When the brakes are applied because of an unforeseen hazard when the motorcycle is banked for cornering, within the physical limits that apply to motorcycling the system prevents the wheels from locking and skidding away.

NOTICE

ABS Pro was not developed to enhance individual braking performance with the motorcycle banked into corners in situ-

ations approaching the limits of performance. ◀

Parking your motorcycle

Side stand

- Switch off the engine.



ATTENTION

Poor ground underneath the stand

Risk of damage to parts if vehicle topples

- Always check that the ground under the stand is level and firm. ◀



ATTENTION

Additional weight placing strain on the side stand

Risk of damage to parts if vehicle topples

- Do not sit or lean on the vehicle while it is propped on the side stand. ◀
- Extend the side stand and prop the motorcycle on the stand.
- Turn the handlebars all the way to left.
- On a gradient, the motorcycle should always face uphill; select 1st gear.

Centre stand

- Switch off the engine.



ATTENTION

Poor ground underneath the stand

Risk of damage to parts if vehicle topples

- Always check that the ground under the stand is level and firm. ◀



ATTENTION

Centre stand folds in due to sharp movements

Risk of damage to parts if vehicle topples

- Do not lean or sit on the vehicle with the centre stand extended. ◀
- Extend the centre stand and lift the motorcycle onto the stand.
- On a gradient, the motorcycle should always face uphill; select 1st gear.

Refuelling

Fuel grade

Requirement

For optimum fuel consumption, fuel should be sulphur-free or as low-sulphur as possible.



ATTENTION

Engine operation with leaded fuel

Damage to catalytic converter

- Do not attempt to run the vehicle on leaded fuel or fuel with metallic additives (e.g. manganese or iron).◀
- You can run the engine on fuel with a maximum ethanol content of 10 %, i.e. E10.



Recommended fuel grade

Super unleaded (max 10% ethanol, E10)
95 ROZ/RON
89 AKI



Alternative fuel grade

Regular unleaded (power and consumption-related restrictions.) (max. 10 % ethanol, E10)
91 ROZ/RON
87 AKI

- » A conversion is required if the quality is not sufficient. Have the motorcycle programmed beforehand at an authorised BMW Motorrad retailer.

Refuelling



WARNING

Fuel is highly flammable

Risk of fire and explosion

- Do not smoke. Never bring a naked flame near the fuel tank.◀



ATTENTION

Component damage

Component damage caused by overfilled fuel tank

- Overfilling the fuel tank will cause excess fuel to penetrate the carbon canister and cause component damage.
- Fill the fuel tank up to the lower edge of the filler neck only.◀



ATTENTION

Wetting of plastic surfaces by fuel

Damage to the surfaces (surfaces become unsightly or dull)

- Clean plastic surfaces immediately after contact with fuel.◀
- Make sure the ground is level and firm and place the motorcycle on its centre stand.

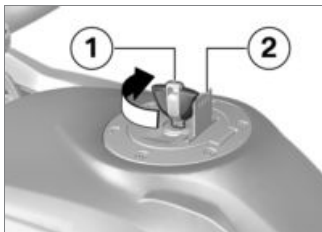

- Open the protective cap **2**.
- Use ignition key **1** to unlock fuel filler cap by turning it clockwise, and flip the cap open.



- Refill with fuel up to the lower edge of the fuel filler neck.

NOTICE

When refuelling after running on reserve, make sure that you top up the tank to a level above reserve, as otherwise the new level will not be registered and the fuel warning light indicating that the level is down to reserve will not be switched off. ◀

NOTICE

The "usable fuel capacity" specified in the technical data is the

quantity that the fuel tank could hold if refilled after it had been run dry and the engine had cut out due to a lack of fuel. ◀



Usable fuel capacity

approx. 20 l



Reserve fuel

approx. 4 l

- Press the fuel tank cap down firmly to close.
- Remove the ignition key and close the protective cap.

Refuelling

– with Keyless Ride^{OE}

Requirement

The steering lock is disengaged.

! WARNING

Fuel is highly flammable

Risk of fire and explosion

- Do not smoke. Never bring a naked flame near the fuel tank.◀

! WARNING

Escape of fuel due to heat-induced expansion if fuel tank is overfilled

Risk of falling

- Do not overfill the fuel tank.◀

! ATTENTION

Wetting of plastic surfaces by fuel

Damage to the surfaces (surfaces become unsightly or dull)

- Clean plastic surfaces immediately after contact with fuel.◀

- Make sure the ground is level and firm and place the motorcycle on its centre stand.
- with Keyless Ride^{OE}
- Switching off ignition (▶▶▶ 59).

! NOTICE

The fuel filler cap can be opened within the defined waiting time after the ignition has been switched off, without the radio-operated key being within range.◀

 Waiting time for opening fuel filler cap

2 min

- » There are **two variant ways** of opening the fuel filler cap:
 - Within the waiting time.
 - After the waiting time has expired.

Version 1

– with Keyless Ride^{OE}

Requirement

Within the waiting time



- Pull up tab **1** of the fuel filler cap slowly.
- » Fuel filler cap unlocks.
- Fully open the fuel filler cap.

Version 2

– with Keyless Ride^{OE}

Requirement

After the waiting time has expired

- Bring the radio-operated key into range.
- Slowly pull tab **1** up.
 - » The telltale light for the radio-operated key flashes while the search for the radio-operated key is in progress.
- Again slowly pull up tab **1** of the fuel filler cap.
 - » Fuel filler cap unlocks.
- Fully open the fuel filler cap.



- Refuel with fuel of the grade stated above; do not fill the tank past the bottom edge of the filler neck.

**NOTICE**

When refuelling after running on reserve, make sure that you top up the tank to a level above reserve, as otherwise the new level will not be registered and the fuel warning light indicating that the level is down to reserve will not be switched off.◀

**NOTICE**

The "usable fuel capacity" specified in the technical data is the quantity that the fuel tank could hold if refilled after it had been run dry and the engine had cut out due to a lack of fuel.◀



Usable fuel capacity

approx. 20 l



Reserve fuel

approx. 4 l

- Press down firmly on the filler cap of the fuel tank.
 - » The fuel filler cap engages with an audible click.
 - » The fuel filler cap locks automatically when the waiting time expires.
 - » The engaged fuel filler cap locks immediately when you secure the steering lock or switch on the ignition.

Securing motorcycle for transportation

- Make sure that all components that might come into contact with straps used to secure the motorcycle are adequately protected against scratching. Use

adhesive tape or soft cloths, for example, for this purpose.



ATTENTION

Vehicle topples to side when being lifted on to stand

Risk of damage to parts if vehicle topples

- Secure the vehicle to prevent it toppling, preferably with the assistance of a second person.◀
- Push the motorcycle onto the transportation flat and hold it in position: do not place it on the side stand or centre stand.



ATTENTION

Trapping of components

Component damage

- Do not trap components such as brake lines or cable legs.◀
- At the front, secure the straps to the handlebars on both sides.
- Pass the straps through the leading link and tighten the straps.



- Secure the tensioning straps at the rear on both sides to the frame for the rear footrest and tighten the straps.
- Tighten all the straps uniformly; the vehicle's suspension should be compressed as tightly as possible front and rear.

Engineering details

General instructions.....	146
Anti-lock brake system (ABS)	146
Automatic Stability Control (ASC)	149
Dynamic Traction Control (DTC)	150
Dynamic ESA.....	152
Riding mode	152
Tyre pressure monitoring (RDC)	155
Shift assistant.....	156
Hill Start Control	157

General instructions

To find out more about engineering, go to:

bmw-motorrad.com/technology

Anti-lock brake system (ABS)

Partially integral brakes

Your motorcycle is equipped with partially integral brakes. Both front and rear brakes are applied when you pull the handbrake lever. The footbrake lever acts only on the rear brake.

While the brakes are slowing the motorcycle with ABS actively intervening, the BMW Motorrad Integral ABS adapts braking-force distribution between front and rear brakes to suit the load on the motorcycle.



ATTENTION

Attempted burn-out despite Integral braking function

Damage to rear brake and clutch

- Do not burn out tyres.◀

How does ABS work?

The amount of braking force that can be transferred to the road depends on factors that include the coefficient of friction of the road surface. Loose stones, ice and snow or a wet road all have much lower coefficients of friction than a clean and dry asphalt surface. The lower the coefficient of friction, the longer the braking distance.

If the rider increases braking pressure to the extent that braking force exceeds the maximum transferable limit, the wheels start to lock and the vehicle loses its directional stability; a fall is imminent. Before this situation oc-

curs the ABS will be activated and the brake pressure adapted to the maximally transferable braking force. The wheels continue to turn and the driving stability is retained irrespective of the road condition.

What are the effects of surface irregularities?

Humps and surface irregularities can cause the wheels to lose contact temporarily with the road surface; if this happens the braking force that can be transmitted to the road can drop to zero. If the rider brakes in this situation, the ABS has to reduce the brake pressure in order to ensure driving stability when resuming contact with the road. Up to this point, BMW Motorrad Integral ABS assumes an extremely low coefficient of friction (gravel, ice, snow) so that the road wheels turn in every conceivable situ-

ation and so ensure driving stability. As soon as it registers the actual circumstances, the system reacts instantly and adjusts braking force accordingly to achieve optimum braking.

What feedback does the rider receive from the BMW Motorrad Integral ABS?

If the ABS system has to reduce braking force on account of the circumstances described above, vibration is perceptible through the handbrake lever.

When the handbrake lever is pulled, brake pressure is also built up at the rear wheel by the integral function. If the brake pedal is depressed after the handbrake lever is pulled, the brake pressure built up beforehand is perceptible as counter-pressure sooner than is the case when the brake pedal is

depressed either before or at the same time as the brake lever is pulled.

Rear wheel lift

Under very severe and sudden deceleration, however, under certain circumstances it is possible that the BMW Motorrad Integral ABS will be unable to prevent the rear wheel from lifting clear of the ground. If this happens the outcome can be a highside situation in which the motorcycle can flip over.



Rear wheel lift due to severe braking

Risk of falling

- When you brake sharply, bear in mind that ABS control cannot always be relied on to prevent the rear wheel from lifting clear of the ground. ◀

What is the design baseline for BMW Motorrad Integral ABS?

Within the limits imposed by physics, the BMW Motorrad Integral ABS ensures directional stability on any surface. The system is not optimised for special requirements that apply under extreme competitive situations off-road or on the track. The driving behaviour should be adapted to actual driving skills and the road conditions.

Special situations

The speeds of the front and rear wheels are compared as one means of detecting a wheel's incipient tendency to lock. If the system registers implausible values for a lengthy period the ABS function is deactivated for safety reasons and an ABS fault message is issued. Self-dia-

gnosis has to complete before fault messages can be issued.

In addition to problems with the BMW Motorrad ABS, exceptional riding conditions can also cause a fault message to be issued:

- Heating up with the motorcycle on the centre stand or an auxiliary stand, engine idling or with a gear engaged.
- Rear wheel locked by the engine brake for a lengthy period, for example while descending on a loose or slippery surface.

If a fault message is issued on account of exceptional riding conditions, you can reactivate the ABS function by switching the ignition off and on again.

What significance devolves on regular maintenance?



WARNING

Brake system not regularly serviced.

Risk of accident

- In order to ensure that the ABS is always maintained in optimum condition, it is essential for you to comply strictly with the specified inspection intervals. ◀

Reserves for safety

The potentially shorter braking distances which BMW Motorrad Integral ABS permits must not be used as an excuse for careless riding. ABS is primarily a means of ensuring a safety margin in genuine emergencies.



WARNING

Braking when cornering

Risk of accident despite ABS

- Invariably, the rider bears responsibility for assessing road and traffic conditions and adopting his or her style of riding accordingly.
- Do not take risks that would negate the additional margin of safety offered by this system. ◀

Evolution of ABS to ABS Pro

– with riding modes Pro^{OE}

Until now, the BMW Motorrad ABS helped ensure a very high degree of safety for braking with the motorcycle upright and travelling in a straight line. Now ABS Pro offers enhanced safety for braking in corners as well. ABS Pro prevents the wheels from locking even under

sharp braking. ABS Pro reduces abrupt changes in steering force, particularly in panic-braking situations, counteracting the vehicle's otherwise natural but undesirable tendency to straighten up.

ABS intervention

Technically speaking, depending on the riding situation ABS Pro adapts ABS intervention to the motorcycle's bank angle. Signals for rate of roll and rate of yaw and lateral acceleration are used to calculate bank angle. As the motorcycle is heeled over more and more as it banks into a corner, an increasingly strict limit is imposed on the brake-pressure gradient for the start of brake application. This slows the build-up of brake pressure to a corresponding degree. Additionally, pressure modulation is more

uniform across the range of ABS intervention.

Advantages for the rider

The advantages of ABS Pro for the rider are sensitive response and high braking and directional stability combined with best-case deceleration of the motorcycle, even when cornering.

Automatic Stability Control (ASC)

How does ASC work?

BMW Motorrad ASC compares the speed of rotation of the front wheel and the rear wheel. The differential is used to compute slip as a measure of the reserves of stability available at the rear wheel. If slip exceeds a certain limit, the engine control intervenes and adapts the engine torque accordingly.

What is the design baseline for BMW Motorrad ASC?

BMW Motorrad ASC is designed as an assistant system for the rider and for use on public roads. The extent to which the rider affects ASC control can be considerable (weight shifts when cornering, items of luggage loose on the motorcycle), especially when the style of riding takes rider and machine close to the limits imposed by physics.

Activate the Enduro mode for off-roading. This mode delays ASC intervention slightly in order to permit controlled drifting. The system is not optimised for special requirements that apply under extreme competitive situations off-road or on the track. The BMW Motorrad ASC can be deactivated in these cases.

WARNING

Risky riding

Risk of accident despite ASC

- Invariably, the rider bears responsibility for assessing road and traffic conditions and adopting his or her style of riding accordingly.
- Do not take risks that would negate the additional safety offered by this system.◀

Dynamic Traction Control (DTC)

How does traction control work?

Traction control is available in two versions

- **without** provision for the bank angle: Automatic Stability Control ASC
- ASC is a rudimentary function intended to prevent falls.

- **with** provision for bank angle: Dynamic Traction Control DTC
- DTC regulation is more delicate and more comfortable thanks to the additional bank angle and acceleration information.

The traction control system compares the speed of rotation at the circumferences of the front wheel and the rear wheel. The differential is used to compute slip as a measure of the reserves of stability available at the rear wheel. If slip exceeds a certain limit, the engine management system intervenes and adapts engine torque accordingly.

WARNING

Risky riding

Risk of accident despite DTC

- Invariably, the rider bears responsibility for assessing road and traffic conditions and ad-

opting his or her style of riding accordingly.

- Do not take risks that would negate the additional safety offered by this system.◀

Special situations

In accordance with the laws of physics, the ability to accelerate is restricted more and more as the angle of heel increases. Consequently, there can be a perceptible reduction in acceleration out of very tight bends.

The speeds of the front and rear wheels are compared and DTC, unlike ASC, also takes the bank angle into account in processing data to detect the rear wheel's incipient tendency to spin or slip sideways.

– with riding modes Pro^{OE}

If the electronic processor receives values for the bank angle that it considers implausible over a lengthy period, a dummy value is used for the bank angle or the DTC function is switched off. Under these circumstances the indicator for a DTC fault shows. Self-diagnosis has to complete before fault messages can be issued.

The BMW Motorrad Traction Control can shut down automatically under the exceptional riding conditions outlined below.

Exceptional riding conditions:

- Riding for a lengthy period with the front wheel lifted off the ground (wheelie).
- Rear wheel rotating with the vehicle held stationary by applying the front brake (burn-out).

– Heating up with the motorcycle on an auxiliary stand, in neutral or with a gear engaged.

If the encoding plug is not inserted, the DTC is reactivated after a fault has occurred by switching the ignition off and on and then by continuing to drive at a low speed.

	Minimum speed for activation of DTC
min 5 km/h	

If the front wheel lifts clear of the ground under severe acceleration, the ASC or DTC reduces engine torque in the RAIN and ROAD riding modes until the front wheel regains contact with the ground.

The ENDURO and ENDURO PRO riding modes are designed for off-road operation and not for on-road operation.

In DYNAMIC, DYNAMIC PRO and ENDURO riding modes, the front wheel lift-off detection allows for short wheelies.

In ENDURO PRO riding mode, the front wheel lift-off detection is switched off.

BMW Motorrad recommends turning the throttle grip back slightly when lifting the front wheel in order to reach a stable driving condition again as soon as possible.

When riding on a slippery surface, never snap the throttle grip fully closed without pulling the clutch at the same time. Engine braking torque can cause the rear wheel to skid, with a corresponding loss of stability. The BMW Motorrad DTC is unable to control a situation of this nature.

Dynamic ESA

– with Dynamic ESA^{OE}

Riding position equaliser

The electronic chassis and suspension adjustment

Dynamic ESA is able to adjust your motorcycle automatically to the load. If the spring preload is set to `AUTO`, the rider does not have to change the load settings. When driving off and when riding, the system monitors the suspension on the rear wheel and corrects the spring preload in order to set the riding position correctly. The damping is also adjusted automatically to the load.

Via ride height sensors, Dynamic ESA detects the movements in the chassis and suspension and responds by adjusting the EDC valves. The chassis and suspension will thus

be adapted to the characteristics of the terrain.

Dynamic ESA calibrates itself at regular intervals to ensure the system functions correctly.

Possible settings

Damping modes

- Road: Damping for comfortable on-road mode
- Dyna.: Damping for dynamic on-road mode
- Enduro: Damping for off-road mode

Load settings

- Auto: Active riding position equaliser with automatic adjustment of the spring preload and damping
- Min: Minimum spring preload
- Max: Maximum spring preload (for off-road use)
- The Min and Max spring preloads can be selected by the rider but not changed. The rid-

ing position equaliser is inactive when set to Min and Max.

Riding mode

Selection

To adjust the motorcycle to the road condition and the desired driving experience, the following riding modes can be selected:

- RAIN
- ROAD (Standard mode)

- with riding modes Pro^{OE}
- DYNAMIC
- ENDURO

When an encoding plug is installed, the `DYNAMIC PRO` and `ENDURO PRO` riding modes replace the `DYNAMIC` and `ENDURO` riding modes.

For each of these riding modes there is a calibrated setting for the ABS, ASC and DTC sys-

tems as well as for the throttle response.

– with Dynamic ESA^{OE}

The adjustment of the Dynamic ESA also depends on the riding mode selected.

ABS and/or ASC/DTC can be switched off in every riding mode. The following explanations always refer to the driving safety systems that are switched on.

Throttle response

- In RAIN and ENDURO riding modes: restrained
- In ROAD and ENDURO PRO riding modes: direct
- In DYNAMIC and DYNAMIC PRO riding modes: dynamic
- Throttle response can be set differently in the DYNAMIC PRO and ENDURO PRO riding modes using SETUP (▣▣▣ 78).

ABS

- The rear wheel lift-off detection is activated in all riding modes.
- In RAIN, ROAD, DYNAMIC and DYNAMIC PRO riding modes, the ABS is set to on-road mode.
- In ENDURO riding mode the ABS is set to off-road mode with road tyres.
- with riding modes Pro^{OE}
- In ENDURO PRO riding mode, there is no ABS control at the rear wheel when the footbrake lever is operated. The ABS has been adjusted to off-road operation using studded tyres.
- ABS can be set differently in the ENDURO PRO riding mode using SETUP (▣▣▣ 78).
- In RAIN, ROAD, DYNAMIC and DYNAMIC PRO riding mode, ABS Pro is fully available. The tendency of the motorcycle to straighten up when the brakes

are applied with the machine banked for cornering is reduced to a minimum.

- In ENDURO riding mode ABS Pro is available only in conditions with a good coefficient of friction. Support is reduced compared with ROAD riding mode and instead, it is configured to generate a maximum braking effect.
- ABS Pro is not available in ENDURO PRO riding mode.
- without riding modes Pro^{OE}

ASC

- The front wheel lift-off detection is activated in all riding modes.
- ASC has been calibrated for on-road operation.
- ASC provides high driving stability in ROAD riding mode and

maximum driving stability in RAIN riding mode.

- with riding modes Pro^{OE}

DTC

Tyres

- In RAIN, ROAD, DYNAMIC and DYNAMIC PRO riding modes, DTC is calibrated to on-road operation with road tyres.
- In ENDURO riding mode, DTC is calibrated to off-road operation with road tyres.
- In ENDURO PRO riding mode, DTC is calibrated to off-road operation with studded tyres.

Driving stability

- In RAIN riding mode, DTC intervenes early enough to achieve maximum driving stability.
- In ROAD riding mode, DTC intervenes later than in RAIN riding mode. This prevents

the rear wheel from spinning whenever possible.

- In RAIN and ROAD riding modes, the front wheel is prevented from lifting.
- In DYNAMIC and DYNAMIC PRO riding modes, DTC intervenes later than in ROAD riding mode meaning that the motorcycle may drift slightly when coming out of the corner or do short wheelies.
- DTC can be set differently in the DYNAMIC PRO riding mode using SETUP (► 78).
- In the ENDURO riding mode, DTC intervenes again later and calibrated to off-road operation so that longer drifts and short wheelies are possible when coming out of the curve.
- In ENDURO PRO riding mode, DTC control assumes that studded tyres are used when off road. Longer wheelies and wheelies in slight lean angles

are permitted. The front wheel lift-off detection is switched off which may cause rollover to the rear in extreme cases!

- DTC can be set differently in the ENDURO PRO riding mode using SETUP (► 78).

Mode changes

The riding mode can be changed while the vehicle is stationary with the ignition on. It is possible to change it while driving under the following conditions:

- No drive torque on the rear wheel.
- No brake pressure in the brake system.

The following steps must be taken to change the riding mode:

- Close the throttle twistgrip.
- Release the brake levers.

The desired riding mode is initially preselected. The mode change does not take place until the systems in question are all in the appropriate state.

The selection menu does not disappear from the display until the mode change has taken place.

Tyre pressure monitoring (RDC)

– with tyre pressure control (RDC)^{OE}

Function

A sensor integrated into each tyre measures the air temperature and the air pressure inside the tyre and transmits this information to the control unit.

The sensors are fitted with a centrifugal-force tripswitch which allows the measured values to be

transmitted after the minimum speed is exceeded the first time.

 Minimum speed for transmission of the RDC measured values:
min 30 km/h

The display shows -- for each tyre until the tyre-pressure signal is received for the first time. The sensors continue to transmit the measured-value signals for some time after the vehicle comes to a stop.

 Transmission duration of the measured values after vehicle standstill:
min 15 min

An error message is issued if wheels without sensors are fitted to a vehicle equipped with an RDC control unit.

Tyre-pressure ranges

The RDC control unit differentiates between three tyre-pressure ranges, all of which are parameterised for the motorcycle:

- Tyre pressure within permitted tolerance.
- Tyre pressure close to limit of permitted tolerance.
- Tyre pressure outside permitted tolerance.

Temperature compensation

Tyre pressure is a temperature-sensitive variable: pressure increases as tyre-air temperature rises and decreases as tyre-air temperature drops. Tyre-air temperature depends on ambient temperature as well as on the style of riding and the duration of the ride.



The tyre pressures are shown in the TFT display as temperature compensated and always refer to the following tyre air temperature:

20 °C

The air lines available to the public in petrol stations and motorway service areas have gauges that do not compensate for temperature; the reading shown by a gauge of this nature is the temperature-dependent tyre-air pressure. As a result, the values displayed there usually do not correspond to the values displayed in the TFT display.

Pressure adaptation

Compare the RDC value on the TFT display with the value in the table on the back cover of the Rider's Manual. Then use the air-line gauge at a service station

to compensate for the difference between the RDC reading and the value in the table.



Example

According to the rider's manual, the tyre pressure should be the following value:

2.5 bar

The following display is shown in the TFT display:

2.3 bar

Missing:

0.2 bar

The tester on the filling station shows:

2.4 bar

The tyre pressure must be increased to the following value to reach the correct tyre pressure:



Example

2.6 bar

Shift assistant

– with riding modes Pro^{OE}

Shift assistant Pro

Your vehicle is equipped with the shift assistant Pro, which was initially developed for racing and has been adapted for touring. It permits upshifts and downshifts without declutching or closing the throttle in virtually all load and rpm ranges.

Advantages

- 70-80 % of all gearshifts on a trip can be done without using the clutch.
- Less relative movement between rider and passenger

because the shift pauses are shorter.

- It is not necessary to close the throttle valve when shifting under acceleration.
- When braking and downshifting (throttle valve closed), engine speed is adjusted by blipping the throttle.
- Shift time is shorter than a gearshift with clutch actuation.

In order for the system to identify a request for a gearshift, the rider has to move the shift lever from its idle position in the desired direction against the force of the spring through a certain "over-travel" at ordinary speed or rapidly and keep the shift lever in this position until the gearshift is completed. It is not necessary to increase the force applied to the shift lever while shifting is in progress. Once the gearshift has completed the shift lever has

to be fully released before another gearshift with the Pro shift assistant can take place. Keep the corresponding load condition (throttle grip position) constant before and during the gear shift for gear shifts using the shift assistant Pro. A change in the position of the throttle twistgrip during a gearshift can cause the function to abort and/or lead to a missed shift. The shift assistant Pro provides no assistance for the gear change if the rider declutches.

Downshifting

- Downshifting is assisted until maximum rpm for the target gear to be selected is reached. This prevents overrewinding.

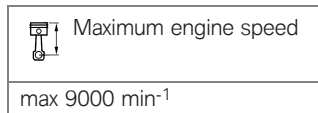

Upshifting

- Upshifting is assisted until idle rpm for the target gear to be selected is reached.
- This prevents the engine from dropping below idle speed.

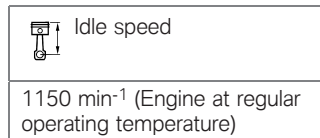

Hill Start Control

- with riding modes Pro^{OE}

Hill Start Control function

Hill Start Control assistant prevents the motorcycle from rolling backwards uncontrolled on gradients by intervening specifically with the ABS brake system without the driver having to constantly operate the brake lever. Pressure in the rear brake sys-

tem is built up when Hill Start Control is activated in order to keep the motorcycle stationary on a steep surface.

Influence of the holding pressure on the driving off behaviour

- If the motorcycle is stopped by applying little brake pressure, only low pressure is built up. In this case, the brakes are quickly released when driving off. The motorcycle can be moved off more gently. It is not necessary to turn the throttle grip again.
- If the motorcycle is stopped by applying high brake pressure, high pressure is built up. In this case, the brakes take longer to release when driving off. More torque is required for driving off which also requires the rider to turn the throttle grip again.

Behaviour when the motorcycle rolls or slips

- If the motorcycle rolls when Hill Start Control is activated, the holding pressure is increased.
- If the rear wheel slips, the brake is released again after approx. 1 m. This prevents, for example, slipping due to a blocked rear wheel.

Releasing the brake when stopping the engine

Hill Start Control is deactivated when the engine is stopped using the emergency stop switch or when the side stand is folded out.

In addition to the indicator and warning lights, the rider should be made aware that Hill Start Control has been deactivated by the following behaviour:

Brake warning jolt

- The brake is released briefly and reactivated immediately.
- This creates a jolt which the rider feels.
- The brake is released slowly.
- The motorcycle is not braked.
- The rider must brake the motorcycle manually.



NOTICE

The holding pressure is released immediately without a brake warning jolt as soon as the ignition is switched off. ◀

Maintenance

General instructions.....	160
Toolkit	160
Service toolkit.....	160
Front-wheel stand	161
Engine oil	162
Brake system	163
Clutch	168
Coolant	168
Tyres	170
Wheel rims and tyres	170
Wheels	171
Air filter	177
Light source	179
Jump-starting.....	184
Battery.....	185

Fuses	189
Diagnostic connector	191

General instructions

The "Maintenance" chapter describes straightforward procedures for checking and replacing certain wear parts.

Special tightening torques are listed as applicable. The tightening torques for the threaded fasteners on your vehicle are listed in the section entitled "Technical data".

Further information on maintenance and repair work is available from your BMW Motorrad authorised dealer in the form of a DVD.

Some of the work requires special tools and a thorough knowledge of the technology involved. If you are in doubt, consult a specialist workshop, preferably your authorised BMW Motorrad dealer.

Toolkit

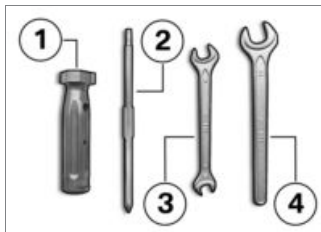

- 1** Screwdriver handle
 - Use with screwdriver insert.
 - Topping up the engine oil (➡ 163).
- 2** Reversible screwdriver blade
 - Phillips PH1 and Torx T25
 - Removing bulbs for front and rear turn indicators (➡ 182).
 - Removing battery cover (➡ 187).
- 3** Open-ended spanner
 - Width across flats 8/10

- 3** – Removing battery (➡ 187).
- 4** Open-ended spanner
 - Width across flats 14
 - Adjusting mirror arm (➡ 118).

Service toolkit

– with service tool kit ^{OA}

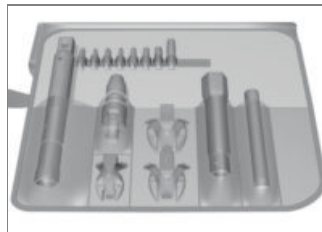

BMW Motorrad has assembled a service toolkit that is ideal for carrying out extended service work (e.g. removing and installing wheels) on this motorcycle. You can obtain the tools set from

your authorised BMW Motorrad dealer.

Front-wheel stand

Installing the front-wheel stand

ATTENTION

Use of the BMW Motorrad front wheel stand without accompanying use of centre stand or auxiliary stand

Risk of damage to parts if vehicle topples

- Place the motorcycle on its centre stand or another auxiliary stand before lifting the front wheel with the BMW Motorrad front-wheel stand. ◀
- Make sure the ground is level and firm and place the motorcycle on its centre stand.
- Use basic stand with front-wheel adapter. The basic stand and its accessory

parts are available from your BMW Motorrad dealer.

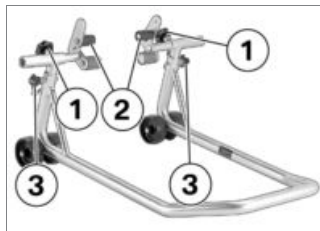

- Remove screws **1**.
- Push the two adapters **2** apart until the front forks fit between them.
- Use locating pins **3** to set the front-wheel stand to the desired height.
- Centre the front-wheel stand relative to the front wheel and push it against the front axle.

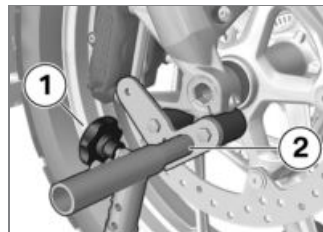

- Align the two adapters **2** so that the front forks are securely seated.
- Tighten screws **1**.

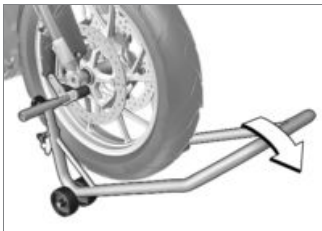

ATTENTION

Centre stand retracts if motorcycle is lifted too high

Risk of damage to parts if vehicle topples

- When raising the vehicle, make sure that the centre stand remains on the ground.◀
- Apply uniform pressure to push the front-wheel stand down and raise the motorcycle.

Engine oil

Checking engine oil level

ATTENTION

Misinterpretation of oil level reading, because oil level is temperature-dependent (the higher the temperature, the higher the oil level)

Engine damage

- Check the oil level only after a lengthy ride or when the engine is at operating temperature.◀
- Switch off the engine when it is at operating temperature.
- Make sure the ground is level and firm and place the motorcycle on its centre stand.
- Wait five minutes for the oil to drain into the oil pan.

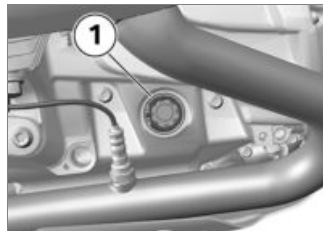

- Check the oil level in oil-level indicator **1**.

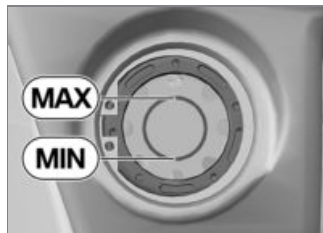

Engine oil, specified level

between MIN and MAX marks

If the oil level is below the MIN mark:

- Topping up the engine oil (►► 163).

If the oil level is above the MAX mark:

- Have the oil level corrected by a specialist workshop, preferably an authorised BMW Motorrad dealer.

Topping up the engine oil

- Place the motorcycle on its stand on firm, even ground.

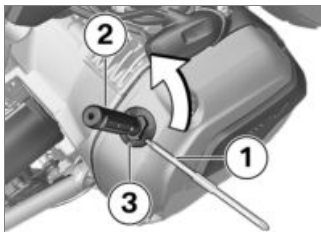

- Wipe the area around the oil filler neck clean.
- Insert Torx end of reversible screwdriver insert **1** into screwdriver handle **2** (on-board tool-kit) for additional leverage.
- Engage this tool in cap **3** of the oil filler neck and turn counter-clockwise to remove.
- Checking engine oil level (►► 162).



ATTENTION

Use of insufficient engine oil or too much engine oil

Engine damage

- Always make sure that the oil level is correct.◀
- Top up the engine oil to the specified level.



Engine oil, quantity for topping up

max 0.95 l (Difference between MIN and MAX)

- Checking engine oil level (►► 162).
- Install cap **3** of the oil filler neck.

Brake system

Checking function of brakes

- Pull the front brake lever.
 - » The pressure point must be clearly perceptible.
- Press the footbrake lever.
 - » The pressure point must be clearly perceptible.

If pressure points are not clearly perceptible:



ATTENTION

Work on brake system not in compliance with correct procedure

Risk to operational reliability of the brake system

- Have all work on the brake system undertaken by trained and qualified specialists. ◀
- Have the brakes checked by a specialist workshop, preferably an authorised BMW Motorrad dealer.

Checking front brake pad thickness

- Place the motorcycle on its stand on firm, even ground.



- Visually inspect the left and right brake pads to ascertain their thickness. View: between the wheel and front suspension through to the brake pads **1**.



Brake-pad wear limit, front

1.0 mm (Friction pad only, without backing plate. The wear indicators (grooves) must be clearly visible.)

If the wear indicating marks are no longer clearly visible:

WARNING

Brake-pad thickness less than permissible minimum

Diminished braking effect, damage to the brakes

- In order to ensure the dependability of the brake system, do not permit the brake pads to wear past the minimum permissible thickness. ◀
- Have the brake pads replaced by a specialist workshop, preferably an authorised BMW Motorrad dealer.

Check rear brake pad thickness

- Place the motorcycle on its stand on firm, even ground.



- Visually inspect the brake pads to ascertain their thickness. View: between the spray guard and rear suspension through to the brake pads **1**.

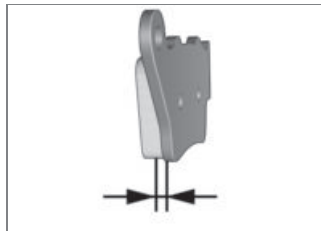

 Brake-pad wear limit, rear

1.0 mm (Friction pad only, without backing plate.)

If the wear limit has been reached:

WARNING

Brake-pad thickness less than permissible minimum

Diminished braking effect, damage to the brakes

- In order to ensure the dependability of the brake system, do not permit the brake pads to wear past the minimum permissible thickness. ◀
- Have the brake pads replaced by a specialist workshop, preferably an authorised BMW Motorrad dealer.

Checking brake-fluid level, front brakes

WARNING

Not enough brake fluid in brake fluid tank

Considerably reduced braking power due to air in the brake system

- Adjust the riding mode immediately until the fault is rectified.
- Check the brake-fluid level at regular intervals. ◀
- Make sure the ground is level and firm and place the motorcycle on its centre stand.
- Move the handlebars to the straight-ahead position.



- Check the brake fluid level in front reservoir **1**.

NOTICE

Wear of the brake pads causes the brake fluid level in the reservoir to sink. ◀



 Brake fluid level, front

Brake fluid, DOT4

It is impermissible for the brake fluid level to drop below the MIN mark. (Brake-fluid reservoir horizontal, motorcycle upright)

If the brake fluid level drops below the permitted level:

- Have the defect rectified as quickly as possible by a specialist workshop, preferably an authorised BMW Motorrad dealer.

Checking the brake-fluid level, rear brakes

WARNING

Not enough brake fluid in brake fluid tank

Considerably reduced braking power due to air in the brake system

- Adjust the riding mode immediately until the fault is rectified.
- Check the brake-fluid level at regular intervals.◀
- Make sure the ground is level and firm and place the motorcycle on its centre stand.



- Check the brake fluid level in rear reservoir **1**.

NOTICE

Wear of the brake pads causes the brake fluid level in the reservoir to sink.◀

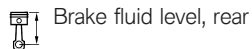

Brake fluid, DOT4

It is impermissible for the brake fluid level to drop below the MIN mark. (Brake-fluid reservoir horizontal, motorcycle upright)

If the brake fluid level drops below the permitted level:

- Have the defect rectified as quickly as possible by a specialist workshop, preferably an authorised BMW Motorrad dealer.

Clutch

Checking clutch function

- Pull the clutch lever.
 - » The pressure point must be clearly perceptible.
- If the pressure point is not clearly perceptible:

- Have the clutch checked by a specialist workshop, preferably an authorised BMW Motorrad dealer.

Coolant

Check coolant level

- Place the motorcycle on its stand on firm, even ground.



CAUTION

Hot engine

Risk of burn injury

- Keep ell clear of all hot engine components.
- Do not touch hot engine components. ◀
- Check the coolant level in expansion tank **1**.



Coolant target level

between the **MIN** and **MAX** marking on the expansion tank (Engine cold)

If the coolant drops below the permitted level:

- Top up coolant (➡ 169).

Topping up coolant

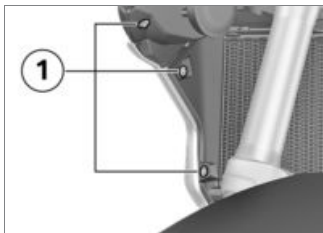

- Remove screws **1**.

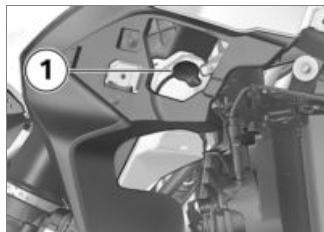

- Open the cap **1**.
- Top up coolant to specified level.
- Check coolant level (→ 168).
- Close the cap of the expansion tank.



- Remove screws **1**.
- Pull the side trim panel **2** off the clamp **3** and remove it.



- Insert the side trim panel **2** into the slot **4**.
- Engage the clamp **3**.



- Install screws **1**.

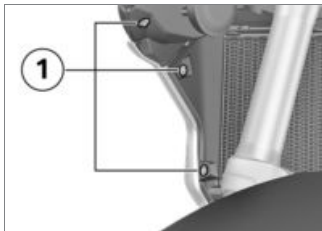

- Install screws **1**.

Tyres

Checking tyre pressure

WARNING

Incorrect tyre pressure

Impaired handling characteristics of the motorcycle, shorter useful tyre life

- Always check that the tyre pressures are correct.◀

WARNING

Tendency of valve inserts installed vertically to open by themselves at high riding speeds

Sudden loss of tyre pressure

- Install valve caps fitted with rubber sealing rings and tighten firmly.◀
- Place the motorcycle on its stand on firm, even ground.
- Check tyre pressures against the data below.



Tyre pressure, front

2.5 bar (tyre cold)



Tyre pressure, rear

2.9 bar (tyre cold)

If tyre pressure is too low:

- Correct tyre pressure.

Wheel rims and tyres

Checking rims

- Place the motorcycle on its stand on firm, even ground.
- Visually inspect the rims for defects.
- Have damaged rims inspected by a specialist workshop and replaced if necessary, preferably by an authorised BMW Motorrad dealer.

Checking tyre tread depth

WARNING

Riding with badly worn tyres

Risk of accident due to impaired handling

- If applicable, have the tyres changed in good time before they wear to the minimum tread depth permitted by law.◀

- Place the motorcycle on its stand on firm, even ground.
- Measure the tyre tread depth in the main tread grooves with wear marks.



NOTICE

Wear indicators are built into the main profile grooves on each tyre. The tyre is worn out when the tyre tread has worn down to the level of the marks. The locations of the marks are indicated on the edge of the tyre, e.g. by the letters TI, TWI or by an arrow. ◀

If the tyre tread is worn to minimum:

- Replace tyre or tyres, as applicable.

Checking spokes

– with cross-spoked wheels^{OE}

- Place the motorcycle on its stand on firm, even ground.
- Use a screwdriver handle or similar object to brush over the spokes and pay attention to the sequence of sounds.

If the sequence of sounds is irregular:

- Have the spokes checked by a specialist workshop, preferably by an authorised BMW Motorrad Retailer.

Wheels

Effect of wheel size on chassis and suspension control systems

Wheel size is very important as a parameter for the chassis and suspension control systems ABS and ASC. In particular, the diameter and the width

of a vehicle's wheels are programmed into the control unit and are fundamental to all calculations. Any change in these influencing variables, caused for example by a switch to wheels other than those installed ex-works, can have serious effects on the performance of the control systems.

The sensor rings are essential for correct road-speed calculation, and they too must match the motorcycle's control systems and consequently cannot be changed.

If you decide that you would like to fit non-standard wheels to your motorcycle, it is very important to consult a specialist workshop beforehand, preferably an authorised BMW Motorrad dealer. In some cases, the data programmed into the control units can be changed to suit the new wheel sizes.

RDC label

- with tyre pressure control (RDC)^{OE}

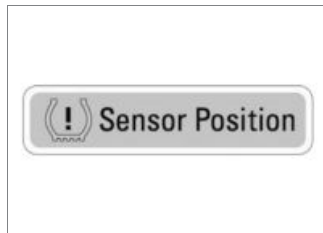

ATTENTION

Tyre removal not in compliance with correct procedure

Damage to RDC sensors

- Be sure to explain to the specialist workshop or authorised BMW Motorrad dealer that the wheel is fitted with an RDC sensor. ◀

If the motorcycle is equipped with RDC, each wheel rim bears

an adhesive label indicating the position of the RDC sensor. When changing the tyre, take care not to damage the RDC sensor. Be sure to draw the attention of the authorised BMW Motorrad dealer or specialist workshop to the fact that the wheel is fitted with an RDC sensor.

Removing front wheel

- Make sure the ground is level and firm and place the motorcycle on its centre stand.

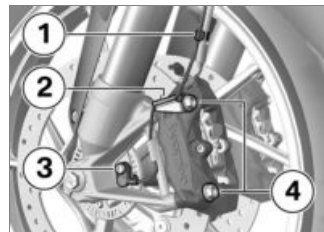

- Disengage the cable for the wheel-speed sensor from retaining clips **1** and **2**.
- Remove screw **3** and remove the wheel-speed sensor from its bore.
- Mask off the parts of the wheel rim that could be scratched in the process of removing the brake calipers.



ATTENTION

Unwanted inward movement of the brake pads

Component damage on attempt to install the brake caliper or be-

cause brake pads have to be forced apart

- Do not operate the brakes with a brake caliper not correctly secured.◀
- Remove securing screws **4** of the left and right brake calipers.

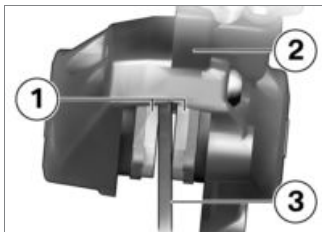

- Force the brake pads **1** slightly apart by rotational movement of the brake caliper **2** against brake disc **3**.
- Carefully pull the brake calipers back and out until clear of the brake discs.

- Lift the front of the motorcycle until the front wheel is clear of the ground, preferably using a BMW Motorrad front-wheel stand.
- Installing the front-wheel stand (► 161).

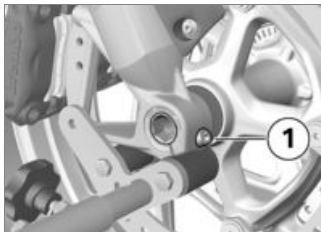

- Remove right-hand axle clamping screw **1**.

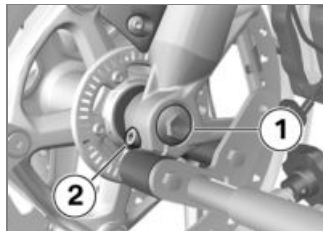

- Remove screw **1**.
- Remove left-hand axle clamping screw **2**.
- Press quick-release axle slightly toward the inside, so as to be better able to grip it on the right-hand side.

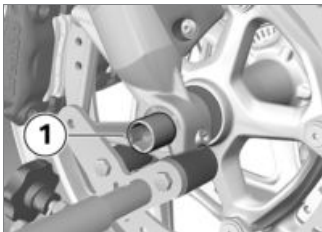

- Withdraw quick-release axle **1**, support the front wheel when doing this.
- Set down front wheel and roll forwards out of the front suspension.

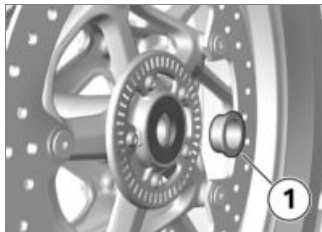

- Remove spacer bush **1** from the wheel hub.

Installing front wheel



WARNING

Use of a non-standard wheel

Malfunction as part of ABS and ASC control interventions

- See the information on the effect of wheel size on the ABS and ASC systems at the start of this chapter. ◀



ATTENTION

Tightening threaded fasteners to incorrect tightening torque

Damage, or threaded fasteners work loose

- Always have the security of the fasteners checked by a specialist workshop, preferably an authorised BMW Motorrad dealer. ◀

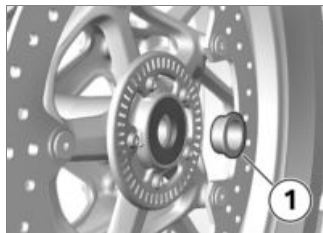

- Slip spacing bushing **1** into the wheel hub on the left-hand side.

ATTENTION

Front wheel installed wrong way round

Risk of accident

- Note direction-of-rotation arrows on tyre or rim. ◀
- Roll the front wheel into position between the front forks.

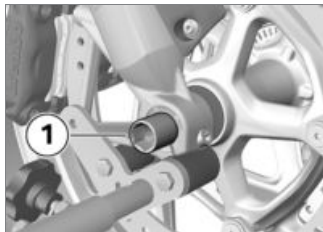

- Lift front wheel and fit quick-release axle **1**.
- Remove front-wheel stand and firmly compress front forks several times. Do not operate front brake lever.

- Installing the front-wheel stand (▶▶ 161).

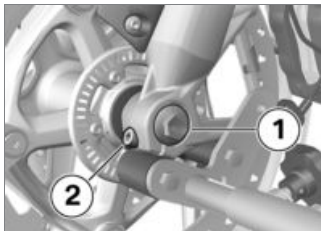

- Install screw **1** and tighten to specified torque. Counter-hold quick-release axle on the right-hand side.

 Quick-release axle in telescopic forks

30 Nm

- Tighten left-hand axle clamping screw **2** to the specified torque.

 Clamping screw for quick-release axle in telescopic fork

19 Nm



- Tighten right axle clamping screw **1** to the specified torque.

 Clamping screw for quick-release axle in telescopic fork

19 Nm

- Removing the front-wheel stand.

- Position left and right brake calipers on the brake discs.

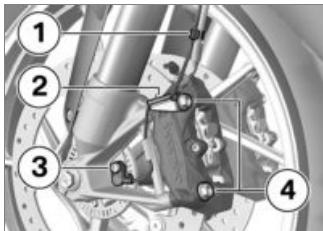

- Install securing screws **4** on left and right and tighten to specified tightening torque.



Brake caliper on telescopic fork

38 Nm

- Remove the adhesive tape from the wheel rim.



WARNING

Brake pads not lying against the brake disc

Risk of accident due to delayed braking effect.

- Before driving, check that the brakes respond without delay.◀
- Operate the brake several times until the brake pads are bedded.
- Seat the cable for the wheel-speed sensor in retaining clips **1** and **2**.
- Insert the wheel-speed sensor into the bore and install screw **3**.



Wheel-speed sensor to fork leg

Joining compound: Micro-encapsulated

8 Nm

Removing rear wheel

- Make sure the ground is level and firm and place the motorcycle on its centre stand.
- Engage first gear.



CAUTION

Hot exhaust system

Risk of burn injury

- Do not touch a hot exhaust system.◀
- Allow rear silencer to cool down.



- Remove studs **1** from the rear wheel, while supporting the wheel.
- Roll the rear wheel out toward the rear.

Install the rear wheel

WARNING

Use of a non-standard wheel

Malfunction as part of ABS and ASC control interventions

- See the information on the effect of wheel size on the ABS and ASC systems at the start of this chapter. ◀

ATTENTION

Tightening threaded fasteners to incorrect tightening torque

Damage, or threaded fasteners work loose

- Always have the security of the fasteners checked by a specialist workshop, preferably an authorised BMW Motorrad dealer. ◀

- Seat the rear wheel on the rear-wheel adapter.



- Install wheel studs **1** and tighten to specified torque.



Rear wheel to wheel flange

Tightening sequence: tighten in diagonally opposite sequence

60 Nm

Air filter

Replace air filter element



- Removing front seat (►► 92).
- Remove screws **1** and **2**.
- Remove the centre trim panel.

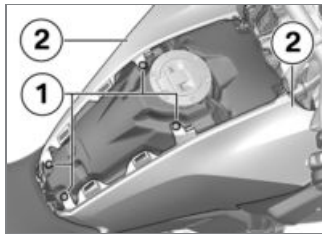

- Remove screws **1**.

- Loosen the cover **2** on both sides.

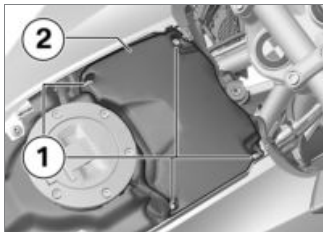

- Remove screws **1**.
- Remove the air filter cover **2**.

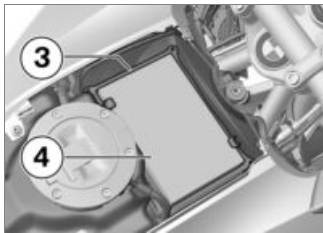

- Remove the frame **3**.

- Removing the air filter element **4**.

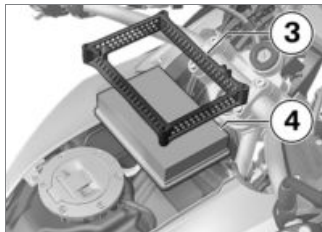

- Clean and (if necessary) renew the air filter element **4**.
- Insert the air filter element **4** and frame **3**.

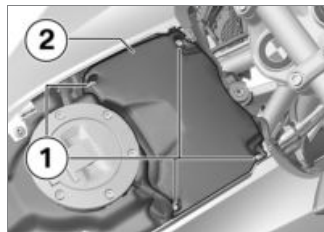

- Fit the air filter cover **2**.
- Install screws **1**.

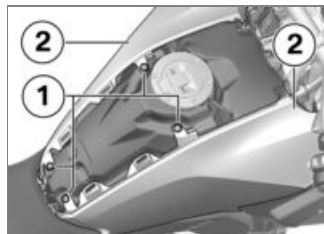

- Position the cover **2** on both sides.
- Install screws **1**.

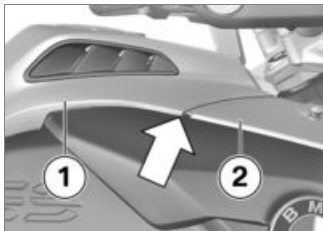

- Position the tank cover **1**; when fitting it make sure that the guide (**arrow**) is below the front-wheel cover above **2**.

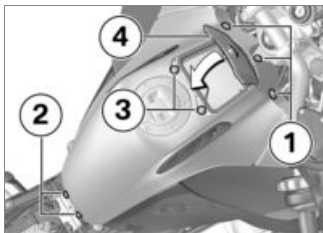

- Install screws **1**, **2** and **3**.

- Open the storage compartment cover **4**.
- Installing front seat (→ 93).

Light source

Replacing bulbs for low-beam and high-beam headlight

– without LED headlight^{OE}

NOTICE

The positions of the plug, the spring wire retainer and the bulb might not be as illustrated below. ◀

- Place the motorcycle on its stand on firm, even ground.
- Switch off the ignition.

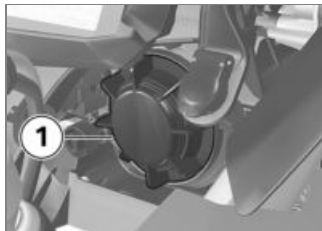

- Remove the cover **1** by turning it anti-clockwise in order to replace the low-beam headlight.



- Remove the cover **1** by turning it anti-clockwise in order to

replace the bulb for the high beam.



- Disconnect plug **1**.

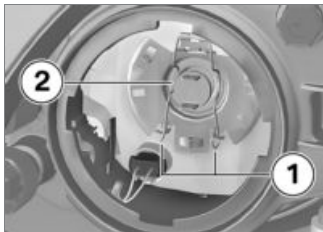

- Disengage spring clips **1** from the fastenings and swing them aside.

- Remove bulb **2**.
- Replace the defective bulb.



Bulbs for the low-beam headlight

H7 / 12 V / 55 W

– with LED headlight^{OE}

LED<



Bulb for high-beam headlight

H7 / 12 V / 55 W

– with LED headlight^{OE}

LED<

- Hold the bulb by the base only, in order to keep the glass free of foreign matter.

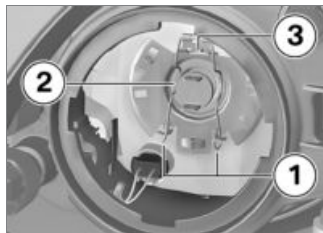

- Insert the bulb **2**, making sure that the tab **3** is correctly positioned.

NOTICE

The bulb might face in a direction other than that shown here. ◀

- Set the wire spring clip **1** into the stop.



- Connect plug **1**.
- Place cover in position and fit by turning clockwise.

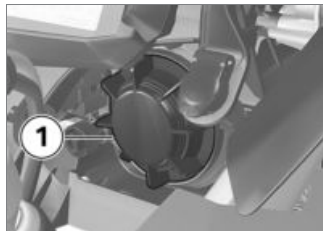

- Remove cover **1** by turning it anti-clockwise.



- Remove bulb **1** from the socket.
- Replace the defective bulb.

Replacing bulb for parking light

– without LED headlight^{OE}

- Place the motorcycle on its stand on firm, even ground.
- Switch off the ignition.

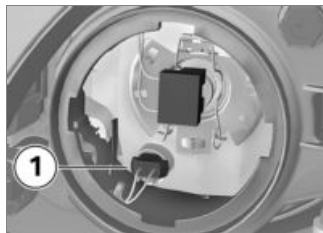

- Pull socket **1** out of the headlight housing.

 Bulb for parking light

W5W / 12 V / 5 W

– with LED headlight^{OE}

LED<

- Use a clean, dry cloth to hold the bulb in order to keep the glass free of foreign matter.



- Insert bulb **1** into the socket.



- Install the socket **1** into the headlight housing.
- Place cover in position and fit by turning clockwise.

Replacing bulbs for front and rear turn indicators

– without LED flashing turn indicators^{OE}

- Place the motorcycle on its stand on firm, even ground.
- Switch off the ignition.



- Remove the bolt **1**.



- Pull the glass out of the reflector housing at the threaded-fastener side.

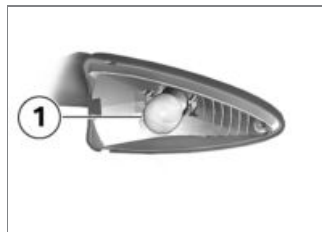

- Remove bulb **1** by turning anti-clockwise from the mirror housing.<

- Replace the defective bulb.

 Bulbs for flashing turn indicators, front

RY10W / 12 V / 10 W

– with LED flashing turn indicators^{OE}

LED<

 Bulbs for flashing turn indicators, rear

RY10W / 12 V / 10 W

– with LED flashing turn indicators^{OE}

LED<

- Use a clean, dry cloth to hold the bulb in order to keep the glass free of foreign matter.

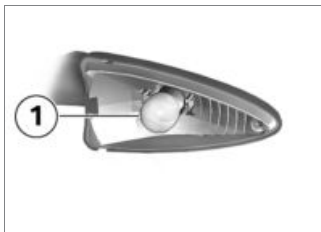

- Turn bulb **1** clockwise to install it in the light housing.



- Working from the inboard side, insert the glass into the light housing and close the housing.



- Install screw **1**.

Replacing LED rear light

The LED rear light can be replaced only as a complete unit.

- Consult a specialist workshop, preferably an authorised BMW Motorrad dealer.

Replace LED flashing turn indicators

– with LED flashing turn indicators^{OE}

- LED flashing turn indicators can only be replaced as a complete unit. Consult a specialist

workshop, preferably an authorised BMW Motorrad dealer.

Replace LED headlights

– with LED headlight^{OE}

- LED headlights can only be replaced as a complete unit. Consult a specialist workshop, preferably an authorised BMW Motorrad dealer.

Replacing LED auxiliary headlights

– with LED auxiliary headlights^{OA}

The LED auxiliary headlights can only be replaced as a unit; it is not possible to replace individual LEDs.

Consult a specialist workshop, preferably an authorised BMW Motorrad dealer.

Jump-starting



CAUTION

Touching live parts of the ignition system when the engine is running

Electric shock

- Do not touch parts of the ignition system when the engine is running. ◀



ATTENTION

Excessive current flowing when the motorcycle is jump-started

Wiring smoulders/ignites or damage to the on-board electronics

- If the motorcycle has to be jump-started connect the leads to the battery terminals; never attempt to jump-start the engine by connecting leads to the on-board socket. ◀



ATTENTION

Contact between crocodile clips of jump leads and vehicle

Risk of short-circuit

- Use jump leads fitted with fully insulated crocodile clips at both ends. ◀



ATTENTION

Jump-starting with a voltage greater than 12 V

Damage to the on-board electronics

- Make sure that the battery of the donor vehicle has a voltage rating of 12 V. ◀
- Place the motorcycle on its stand on firm, even ground.
- Removing battery cover (▣► 187).
- When jump-starting the engine, do not disconnect the battery

from the on-board electrical system.

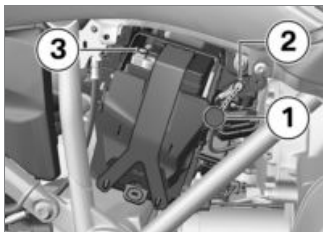

- Remove the protective cap **1**.
- Use the red jump lead to connect the positive battery connection point **2** of the drained battery to the positive terminal of the donor battery.
- Then connect one end of the black jump lead to the negative terminal of the donor battery, and the other end to the negative terminal **3** of the drained battery.
- Run the engine of the donor vehicle during jump-starting.

- Start the engine of the vehicle with the discharged battery in the usual way; if the engine does not start, wait a few minutes before repeating the attempt in order to protect the starter motor and the donor battery.
- Allow both engines to idle for a few minutes before disconnecting the jump leads.
- Disconnect the jump lead from the negative terminals first, then disconnect the second lead from the positive terminals.

NOTICE

Do not use proprietary start-assist sprays or other products to start the engine. ◀

- Install the protective cap.
- Fitting battery cover (▶▶ 189).

Battery

Maintenance instructions

Correct upkeep, recharging and storage will prolong the life of the battery and are essential if warranty claims are to be considered.

Compliance with the points below is important in order to maximise battery life:

- Keep the surface of the battery clean and dry.
- Do not open the battery.
- Do not top up with water.
- Be sure to read and comply with the instructions for charging the battery on the following pages.
- Do not turn the battery upside down.

**ATTENTION****On-board electronics (e.g. clock) draining connected battery**

Battery is deep-discharged; this voids the guarantee

- Connect a float charger to the battery if the motorcycle is to remain out of use for more than four weeks. ◀

**NOTICE**

BMW Motorrad has developed a float charger specially designed for compatibility with the electronics of your motorcycle. Using this charger, you can keep the battery charged during long periods of disuse, without having to disconnect the battery from the motorcycle's on-board systems. You can obtain additional information from your authorised BMW Motorrad dealer. ◀

Charge battery when connected**ATTENTION****Charging the battery that is connected to the vehicle via the battery terminals**

Damage to the on-board electronics

- Disconnect the battery at the battery terminals before charging. ◀

**ATTENTION****Charging a fully discharged battery via the socket or the extra socket**

Damage to the on-board electronics

- If a battery has discharged to the extent that it is completely flat (battery voltage less than 9 V, status-indicator lights and multifunction display remain off when the ignition is switched

on) **it has to be disconnected from the on-board circuits** and re-charged with the charger connected directly to the battery posts. ◀

**ATTENTION****Unsuitable chargers connected to a socket**

Damage to charger and vehicle electronics

- Use suitable BMW chargers. The suitable charger is available from your authorised BMW Motorrad dealer. ◀
- Charge via the charging socket, with the battery connected to the motorcycle's on-board electrical system.

**NOTICE**

The motorcycle's on-board electronics know when the battery is fully charged. The on-board

socket is switched off when this happens.◀

- Comply with the operating instructions of the charger.

NOTICE

If you are unable to charge the battery through the on-board socket, you may be using a charger that is not compatible with your motorcycle's electronics. If this happens, charge the battery directly at the terminals of the battery that is disconnected from the vehicle.◀

Charging battery when disconnected

- Charge the battery using a suitable charger.
- Comply with the operating instructions of the charger.
- Once the battery is fully charged, disconnect the

charger's terminal clips from the battery terminals.

NOTICE

The battery has to be recharged at regular intervals in the course of a lengthy period of disuse. See the instructions for caring for your battery. Always fully recharge the battery before restoring it to use.◀

Removing battery

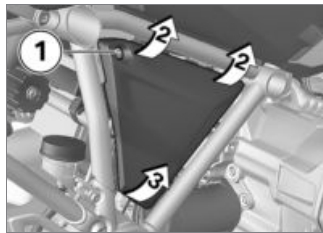

- Switch off the ignition.
- Remove screw **1**.

- Each battery cover slightly forward at the top at positions **2**.
- In order not to damage the battery cover or the mount, work the battery cover up at position **3** to remove.

– with alarm system (DWA)^{OE}

- If applicable, switch off the anti-theft alarm.◀

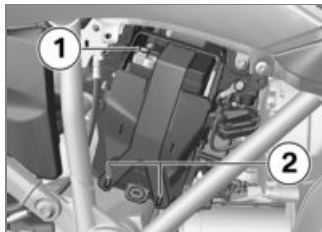

- Disconnect battery negative lead **1** and disengage rubber strap **2**.



- Pull retaining plate in position **1** outwards and remove in an upward direction.
- Slightly lift battery and remove from the mounting to such an extent that the battery positive terminal becomes accessible.

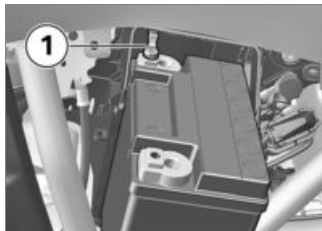

- Disconnect battery negative lead **1** and remove the battery.

Installing battery



NOTICE

If the 12 V battery is not correctly installed or if the polarity of the terminals is reversed (e.g. in an attempt to jump-start the vehicle), this can cause the fuse for the alternator regulator to blow. ◀

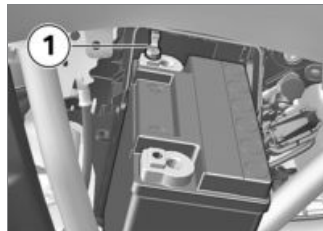

- Secure battery positive lead **1**.
- Push battery into the mounting.

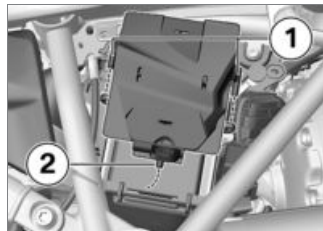

- First insert retaining plate into the mountings **1** and then push under the battery in position **2**.



- Secure battery negative lead **1**.
- Secure the battery with rubber strap **2**.

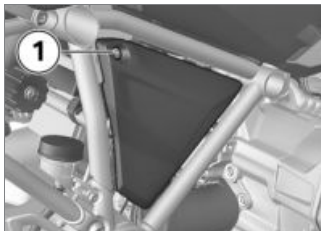

- Install screw **1**.
- Setting the clock (▣▣▣▣ 105).
- Setting the date (▣▣▣▣ 105).

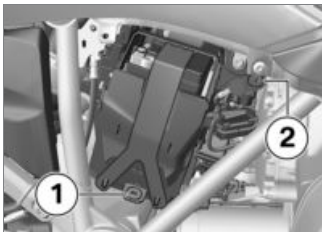

- Place battery cover into the mounting **1** and press into the mountings **2**.

Fuses

Replace fuses

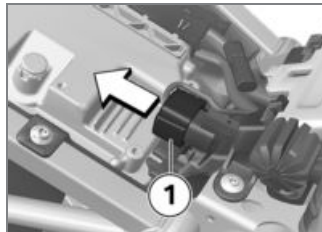

- Switch off the ignition.
- Removing front seat (▣▣▣▣ 92).
- Disconnect plug **1**.

ATTENTION

Jumpering of blown fuses

Risk of short-circuit and fire

- Never attempt to jumper a blown fuse.
- Always replace a defective fuse with a new fuse of the same amperage. ◀

- Replace faulty fuse in accordance with the fuse allocation diagram.

NOTICE

If fuse defects recur frequently have the electric circuits checked by a specialist workshop, preferably an authorised BMW Motorrad dealer. ◀

- Install plug **1**.
- Installing front seat (▶▶▶ 93).

Fuse assignment

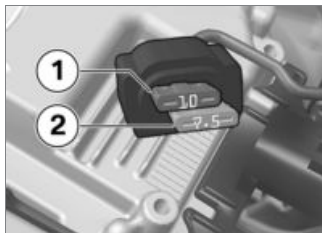

- | | |
|----------|--|
| 1 | 10 A
Instrument panel
Anti-theft alarm (DWA)
Ignition switch
Diagnostic socket |
| 2 | 7.5 A
Multifunction switch, left
Tyre pressure monitoring (RDC) |

Fuse for the alternator regulator

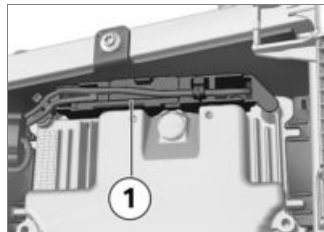

- | | |
|----------|------------------------------|
| 1 | 50 A
Alternator regulator |
|----------|------------------------------|

Diagnostic connector

Disengaging diagnostic connector

CAUTION

Incorrect procedure followed when loosening the diagnostic connector for the on-board diagnosis

Motorcycle experiences malfunctions

- Only have the diagnostic connector loosened by a specialist workshop or other authorised persons during your next BMW Service appointment.
- Have the work performed by appropriately trained staff.
- Refer to the vehicle manufacturer specifications.◀
- Removing battery cover (►► 187).

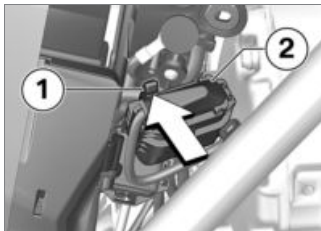

- Press the hook **1** and pull the diagnostic connector **2** out upwards.

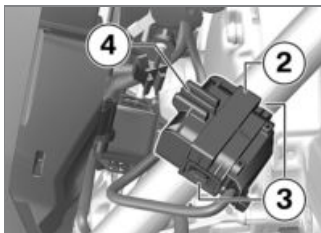

- Press the latches **3** on both sides.

- Disengage diagnostic connector **2** from holder **4**.
» The interface to the diagnosis and information system can be connected to diagnostic connector **2**.

Securing the diagnostic connector

- Disconnect the interface for the diagnosis and information system.

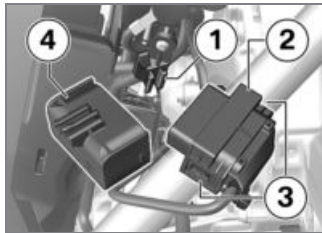

- Seat diagnostic connector **2** in bracket **4**.
» The locks **3** engage on both sides.

- Seat the bracket **4** on the mounting **1**.



- Make sure the hook **5** has engaged.
- Fitting battery cover (☞ 189).

Accessories

General instructions.....	194
Power sockets	194
Cases.....	195
Topcase	198
Navigation system	204

General instructions

CAUTION

Use of other-make products

Safety risk

- BMW Motorrad cannot examine or test each product of outside origin to ensure that it can be used on or in connection with BMW vehicles without constituting a safety hazard. Country-specific official authorisation does not suffice as assurance. Tests conducted by these instances cannot make provision for all operating conditions experienced by BMW vehicles and, consequently, they are not sufficient in some circumstances.
- Use only parts and accessories approved by BMW for your vehicle. ◀

BMW has conducted extensive testing of the parts and ac-

cessory products to establish that they are safe, functional and suitable. Consequently, BMW accepts product liability. BMW accepts no liability whatsoever for parts and accessories that it has not approved.

Whenever you are planning modifications, comply with all the legal requirements. Make sure that the vehicle does not infringe the national road-vehicle construction and use regulations applicable in your country. Your BMW Motorrad dealer can offer expert advice on the choice of genuine BMW parts, accessories and other products. To find out more about accessories go to:

**[bmw-motorrad.com/
accessories](http://bmw-motorrad.com/accessories)**

Power sockets

Connection of electrical devices

- You can start using electrical devices connected to the motorcycle's sockets only when the ignition is switched on.

Cable routing

- The cables from the power sockets to the auxiliary devices must be routed in such a way that they do not impede the rider.
- The cable routing should not restrict the steering angle or obstruct handling.
- The cables must not be trapped.

Automatic shutdown

- The sockets will be automatically switched off during the start procedure.

- The power supply to the sockets is switched off no more than 15 minutes after the ignition is switched off, in order to prevent overloading of the on-board electrics. Low-wattage electrical accessories might not be recognised by the vehicle's electronics. In such cases, power sockets are switched off very shortly after the ignition is turned off.
- If the battery charge state is too low to maintain the motorcycle's start capability, the power sockets are switched off.
- The power sockets are also switched off when the maximum load capability as stated in the technical data is exceeded.

Cases

Opening cases

- with cases^{OA}

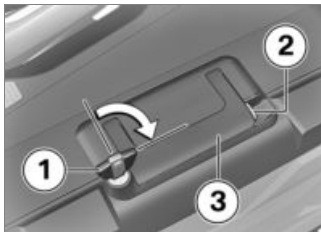

- Turn key **1** clockwise.
- Keep the yellow latch **2** held and fold out the carry handle **3**.



- Push yellow button **1** down and at the same time open the lid of the case.

Adjusting case volume

- with cases^{OA}

- Open the case and remove all its contents.



- Engage pivot lever **1** at the top limit position to set the case to minimum volume.
- Engage pivot lever **1** at the bottom limit position to set the case to maximum volume.
- Close the case.

Closing cases

– with cases^{OA}

- Turn the lock with the key until it is at right angles to the forward direction of travel.
- Close the case lid.

» The lid engages with an audible click.

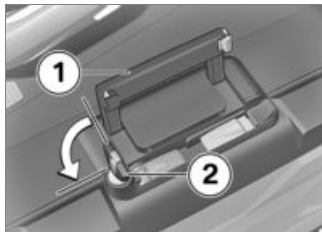

ATTENTION

Closure of carrying handle with case lock latched

Damage to locking tab

- Make sure that the case lock is at right angles to the forward direction of travel when you close the carry handle. ◀
- Close carry handle **1**.
- Turn key **2** counter-clockwise and remove.

Removing cases

– with cases^{OA}

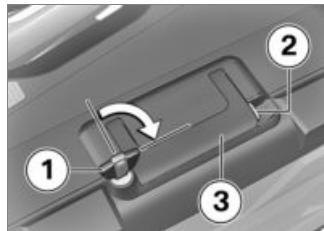

- Turn key **1** clockwise.
- Keep the yellow latch **2** held and fold out the carry handle **3**.



- Pull red release lever **1** up.
- » Latching flap **2** pops up.
- Fully open the latching flap.
- Take a firm grip of the handle and lift the case out of the holder.



- Pull red release lever **1** up.
- » Latching flap **2** pops up.
- Fully open the latching flap.

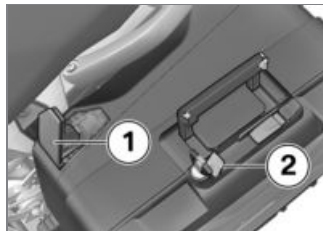

- Press latching flap **1** down until resistance is felt.
- Then simultaneously press down latching flap and red release lever **2**.
- » The latching flap engages.

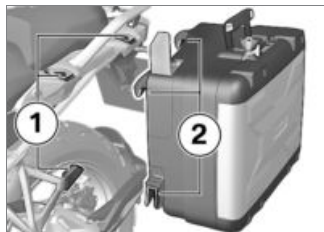

- Place box from the top into the mountings **1** and **2**.

Mounting cases

– with cases^{OA}

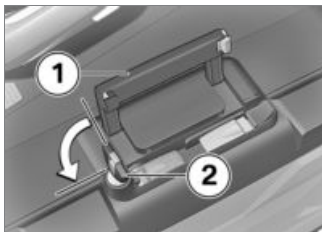

ATTENTION

Closure of carrying handle with case lock latched

Damage to locking tab

- Make sure that the case lock is at right angles to the forward direction of travel when you close the carry handle. ◀
- Close carry handle **1**.
- Turn key **2** counter-clockwise and remove.

Maximum payload and maximum permissible speed

Note the maximum permissible payload and the speed limit for riding with cases fitted, as stated on the label inside the case. Contact your authorised BMW Motorrad dealer if you cannot find your combination of vehicle and cases on the label. The values for the combination described here are as follows:

 Maximum permissible speed for riding with Vario cases fitted to the motorcycle

max 180 km/h

 Payload per Vario case

max 10 kg

Topcase

Opening topcase

– with topcase^{OA}

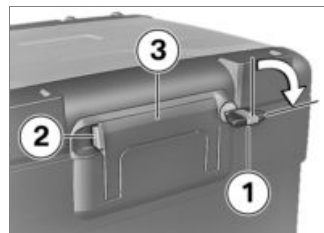

- Turn key **1** clockwise.
- Keep the yellow latch **2** held and fold out the carry handle **3**.

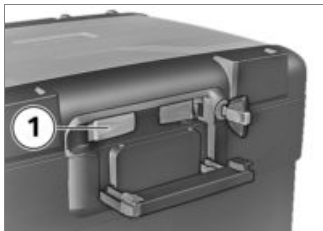

- Push yellow button **1** forward and at the same time open the lid of the topcase.

Adjusting topcase volume

– with topcase^{OA}

- Open the topcase and remove all its contents.



- Engage pivot lever **1** at the front limit position to set the case to maximum volume.
- Engage pivot lever **1** at the rear limit position to set the case to minimum volume.
- Close the topcase.

Closing topcase

– with topcase^{OA}

- Press down firmly on the topcase lid to close.

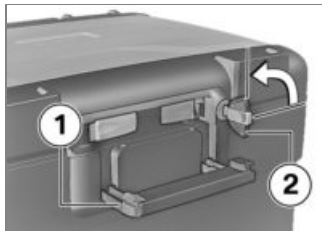

ATTENTION

Closure of carrying handle with case lock latched

Damage to locking tab

- Make sure that the topcase lock is vertical when you close the carry handle. ◀
- Close carry handle **1**.
» The handle engages with an audible click.
- Turn key **2** counter-clockwise and remove.

Removing the topcase

– with topcase^{OA}

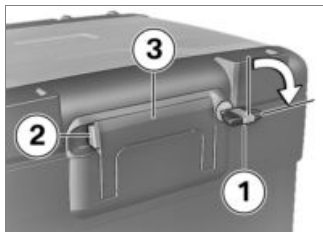

- Turn key **1** clockwise.
- Keep the yellow latch **2** held and fold out the carry handle **3**.

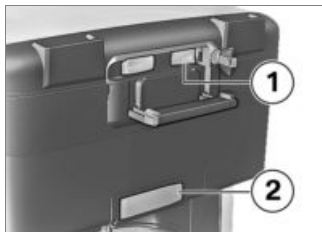

- Pull red lever **1** back as far as it will go.
 - » Latching flap **2** pops up.
- Fully open the latching flap.
- Take a firm grip of the handle and lift the topcase out of the holder.

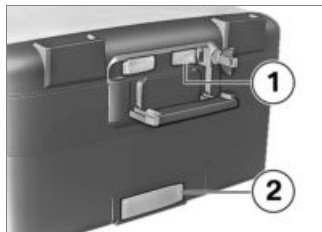

- Pull red lever **1** back as far as it will go.
 - » Latching flap **2** pops up.
- Fully open the latching flap.

Mounting topcase

– with topcase^{OA}

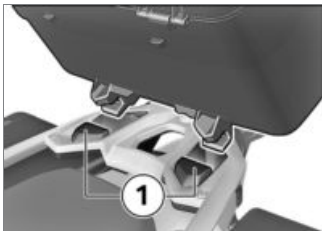

- Engage the topcase in front holders **1** of the topcase carrier plate.
- Press the topcase onto the topcase carrier plate at the rear.



- Press latching flap **1** forward until resistance is felt.
- Next simultaneously press down latching flap and red release lever **2**.
 - » The latching flap engages.

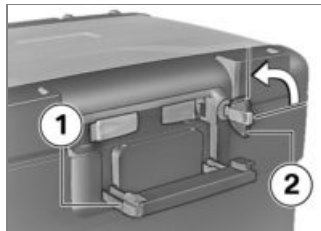

ATTENTION

Closure of carrying handle with case lock latched

Damage to locking tab

- Make sure that the topcase lock is vertical when you close the carry handle.◀
- Close carry handle **1**.
 - » The handle engages with an audible click.
- Turn key **2** counter-clockwise and remove.

Maximum payload and maximum permissible speed

Note the maximum permissible payload and the speed limit for riding with topcase fitted, as stated on the label inside the topcase.

Contact your authorised BMW Motorrad dealer if you cannot find your combination of vehicle and topcase on the label. The values for the combination described here are as follows:



Maximum speed for riding with a laden Vario topcase

max 180 km/h



Payload of Vario topcase

max 5 kg

Installing topcase

– with topcase 2 large, 49 l^{OA}



WARNING

Topcase not properly secured

Driving safety is impaired

- The topcase must not wobble and must be secured free from play. ◀



- Pull handle **1** up as far as it will go.

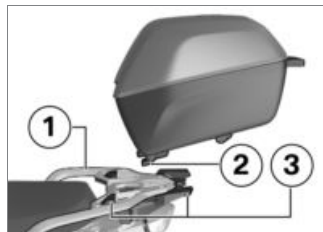

- Hook the topcase into the luggage carrier **1**. Make sure that the hooks **2** fit securely into the fixtures **3**.
- Push the handle down until it engages.



- Turn the key in the topcase lock to position **1** and remove the key from the lock.



Maximum speed for journeys with big topcase 2, 49 l

max 180 km/h



Payload of big topcase 2, 49 l

max 5 kg

- Do not exceed the values for maximum speed and payload.

Opening topcase

– with topcase 2 large, 49 l^{OA}



- Turn the key in the topcase lock to position **1**.

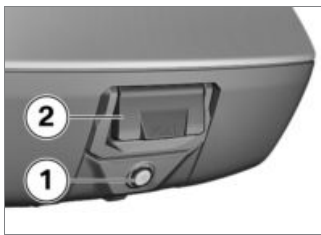

- Push lock barrel **1** forward.

- » Lever **2** pops up.
- Pull the release lever all the way up.
- » The lid of the topcase opens.

Closing topcase

– with topcase 2 large, 49 l^{OA}

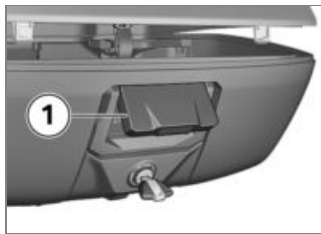

- Pull release lever **1** all the way up.
- Close the lid of the topcase and hold it down. Check that nothing is trapped between the lid and the case.

 **NOTICE**

The topcase can also be locked by turning the lock to the LOCK position. In this case, ensure that the vehicle key is not left in the topcase. ◀

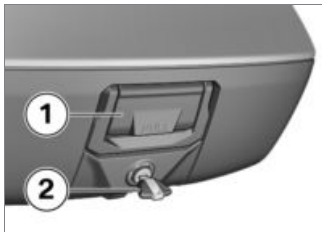

- Push release lever **1** down until it engages.
- Turn key **2** in the topcase lock to the **LOCK** position and remove the key from the lock.

Removing the topcase

– with topcase 2 large, 49 l^{OA}



- Turn the key in the topcase lock to position **1**.
» The handle pops out.



- Pull handle **1** up as far as it will go.
- Lift the topcase at the rear and remove it from the luggage carrier.

Navigation system

– with preparation for navigation system^{OE}

Securing navigation device

 **NOTICE**

The navigation preparation option is compatible with the

BMW Motorrad Navigator IV and the BMW Motorrad Navigator V. ◀

NOTICE

The latching system of the Mount Cradle is not designed to protect against theft.

Always remove the navigation system and stow it away safely as soon as you finish your ride. ◀

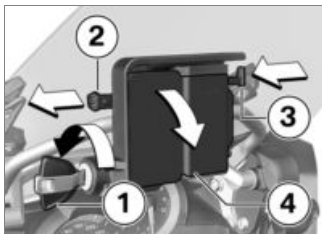

- Turn ignition key **1** counter-clockwise.
- Pull retainer **2** to the **left**.
- Press in lock **3**.

» The Mount Cradle is released and cover **4** can be pivoted forward and removed.

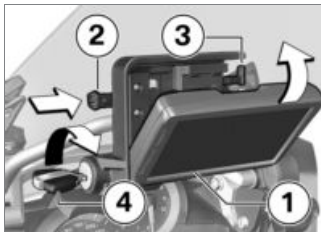

- Insert the navigation system **1** in the lower area and swing it towards the rear in one rotational movement.
- » The navigation device is heard to engage.
- Push retainer **2** fully to the **right**.
- » Lock **3** is engaged.
- Turn ignition key **4** clockwise.
- » The navigation device is secured and the ignition key can be removed.

Removing navigation device and installing cover

ATTENTION

Dust and dirt on the Mount Cradle contacts

Damaged contacts

- Always reinstall the cover as soon as you finish your ride. ◀

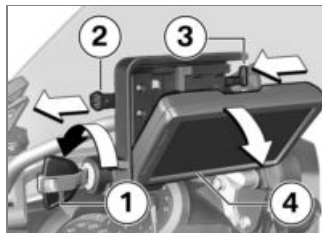

- Turn vehicle key **1** counter-clockwise.
- Pull retainer **2** fully to the **left**.
- » Lock **3** is disengaged.
- Push lock **3** fully to the **left**.

- » Navigation system **4** is unlocked.
- Tilt the navigation device **4** and work it downward to remove.

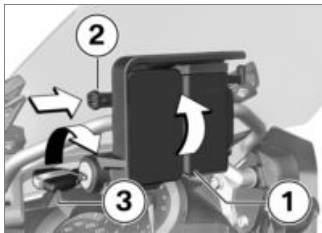

- Insert cover **1** at bottom and pivot it up.
- » The cover engages with an audible click.
- Push retainer **2** to the **right**.
- Turn vehicle key **3** clockwise.
- » Cover **1** is secured.

Operating navigation system

NOTICE

The description below is based on the Navigator V. The Navigator IV does not support all the possibilities described here.◀

NOTICE

Only the latest version of the BMW Motorrad communication system is supported. A software update of the BMW Motorrad communication system may be necessary. If this is the case, consult your authorised BMW Motorrad dealer.◀

If the BMW Motorrad Navigator is installed and the operating focus is switched to the Navigator (101), some of its functions can be operated directly from the handlebars.

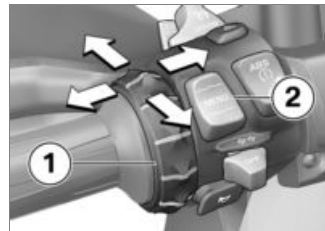

The navigation system is operated via the multi-controller **1** and the MENU rocker button **2**.

Turn the multi-controller **1** up and down

On the compass and Mediaplayer page: increase or decrease the volume of a BMW Motorrad communication system connected via Bluetooth. In the BMW special menu: select menu items.

Briefly tilt the multi-controller 1 to the left and right

Switch between the Navigator's main pages:

- Map view
- Compass
- Mediaplayer
- BMW special menu
- My Motorcycle page

Hold the multi-controller 1 to the left and right

Activate certain functions on the Navigator display. An arrow to the right or to the left above the corresponding button area on the display indicates a function that can be activated in this way.



Long-push to the right to activate this function.



Long-push to the left to activate this function.

Press down MENU rocker button 2

Switch the operating focus to Pure Ride view.

In detail, the following functions can be controlled:

Map view

- Turn up: Enlarge map section (Zoom in).
- Turn down: Reduce map section (Zoom out).

Compass page

- Turning increases or decreases the volume of a BMW Motorrad communication system connected via Bluetooth.

BMW special menu

- Speak: Repeat most recent navigation announcement.

- Waypoint: Save current location as a favourite.
- Home: Starts navigation to home address (greyed if no home address has been defined).
- Mute: Switch automatic navigation announcements off or on (off: a crossed-out lips symbol appears in the top line of the display). "Speak" will still activate navigation announcements. All other acoustic outputs remain switched on.
- Switch off display: Deactivate the display.
- Dial home number: Dials the home phone number saved in the Navigator (not shown unless a communication system and a telephone are connected).
- Diversion: Activates the diversion function (not shown unless a route is active).

- Skip: Skips the next waypoint (not shown unless the route has waypoints).

My Motorcycle

- Turn: Changes the number of data shown.
- Touch a data field on the display to open the menu for selecting data.
- The values available for selection depend on the optional extras installed on the vehicle.

Mediaplayer

- Long-push to the left: Play preceding track.
- Long-push to the right: Play next track.
- Turning increases or decreases the volume of a BMW Motorrad communication system connected via Bluetooth.



NOTICE

The Mediaplayer function is only available when using an A2DP-standard Bluetooth device, for example a BMW Motorrad communication system. ◀

Indicator and warning messages



Indicator and warning messages from the motorcycle are indicated by a symbol **1** which appears at the top left in the map view.



NOTICE

If a BMW Motorrad communication system is connected, warnings are accompanied by an acoustic signal. ◀

If there are two or more active warnings the number appears below the warning triangle.

Touching the warning triangle when more than one warning is active opens a list of all the warnings.

Additional information appears as soon as a message is selected.



NOTICE

Detailed information cannot be displayed for all warnings. ◀

Special functions

Integration of the BMW Motorrad Navigator has produced a number of deviations from the de-

scriptions in the operating instructions for the Navigator.

Reserve fuel level warning

The settings for the fuel gauge are not available, because the reserve fuel level warning is sent by the vehicle to the Navigator. Touch the message when it is active to view the locations of the nearest filling stations.

Time and date

The Navigator sends the time and date to the motorcycle. The transfer of these data into the instrument cluster must be activated in the **SETUP** menu of the instrument cluster.

Security settings

The BMW Motorrad Navigator V can be secured against unauthorised use with a four-digit PIN (Garmin Lock). If this function is activated, while the Navigator is

cradled on the motorcycle and the ignition is switched on you are prompted to add the motorcycle to the list of secured vehicles. If you answer "Yes" at this prompt the Navigator saves the VIN of this vehicle in its internal memory.

A maximum of five VINs can be saved in this way.

Subsequently, the PIN does not have to be entered when the Navigator is switched on by ignition ON while cradled in any of these vehicles.

If the Navigator is removed from the vehicle while switched on, a security prompt asking for the PIN to be entered is issued.

Screen brightness

Screen brightness is adjusted by the motorcycle while the unit is cradled. No manual input is necessary.

If you prefer, you can switch off automatic adjustment in the Navigator display settings.

Care

Care products	212
Washing the vehicle	212
Cleaning easily damaged components.....	213
Paint care	214
Protective wax coating	214
Laying up the motorcycle	214
Restoring motorcycle to use	214

Care products

BMW Motorrad recommends that you use the cleaning and care products you can obtain from your authorised BMW Motorrad dealer.

The substances in BMW Care Products have been tested in laboratories and in practice; they provide optimised care and protection for the materials used in your vehicle.



ATTENTION

Use of unsuitable cleaning and care products

Damage to vehicle parts

- Do not use solvents such as cellulose thinners, cold cleaners, fuel or the like, and do not use cleaning products that contain alcohol. ◀

Washing the vehicle

BMW Motorrad recommends that you use BMW insect remover to soften and wash off insects and stubborn dirt on painted parts prior to washing the vehicle.

To prevent stains, do not wash the vehicle immediately after it has been exposed to strong sunlight and do not wash it in the sun.

Make sure that the vehicle is washed frequently, especially during the winter months.

To remove road salt, clean the motorcycle with cold water immediately after every trip.



WARNING

Wet brake discs and brake pads after vehicle wash, after riding through water and in rainy conditions

Diminished braking effect, risk of accident

- Apply the brakes in good time to allow the friction and heat to dry the brake discs and brake pads. ◀



ATTENTION

Effect of road salt intensified by warm water

Corrosion

- Use only cold water to wash off road salt. ◀



ATTENTION

Damage due to high water pressure from high pressure cleaners or steam cleaners

Corrosion or short circuit, damage to labels, seals, hydraulic brake system, electrical system and the motorcycle seat

- Exercise restraint when using a steam jet or high pressure cleaning equipment.◀

Cleaning easily damaged components

Plastics



ATTENTION

Use of unsuitable cleaning agents

Damage to plastic surfaces

- Do not use cleaning agents that contain alcohol, solvents or abrasives.
- Do not use insect-remover pads or cleaning pads with hard, scouring surfaces.◀

Body panels

Clean the trim panels with water and BMW plastic care emulsion.

Windscreens and lenses made of plastic

Clean off dirt and insects with a soft sponge and plenty of water.



NOTICE

Soften stubborn dirt and insects by covering the affected areas with a wet cloth.◀



Clean with water and sponge only.



Do not use any chemical cleaning agents.

Chrome

Use plenty of water and BMW shampoo to clean chrome, particularly if it has been exposed to road salt. Use chrome polish for additional treatment.

Radiator

Clean the radiator regularly to prevent overheating of the engine due to inadequate cooling. For example, use a garden hose with low water pressure.



ATTENTION

Bending of radiator fins

Damage to radiator fins

- Take care not to bend the radiator fins when cleaning.◀

Rubber components

Treat rubber components with water or BMW rubber-care products.



ATTENTION

Application of silicone sprays to rubber seals

Damage to the rubber seals

- Do not use silicone sprays or care products that contain silicon.◀

Paint care

Washing the vehicle regularly will help counteract the long-term effects of substances that damage the paint, especially if your vehicle is ridden in areas with high air pollution or natural sources of dirt, for example tree resin or pollen.

Remove particularly aggressive substances immediately, however, as otherwise the paint can be affected or become discoloured. Substances of this nature include spilt fuel, oil, grease, brake fluid and bird droppings. We recommend BMW vehicle polish or BMW paint cleaner for this purpose.

Marks on the paintwork are particularly easy to see after the vehicle has been washed. Remove stains of this kind immediately, using cleaning-grade benzene or petroleum spirit on a clean cloth or ball of cotton.

BMW Motorrad recommends using BMW tar remover for removing specks of tar. Remember to wax the parts treated in this way.

Protective wax coating

If water is no longer forming beads on the paint surface, it must be waxed.

BMW Motorrad recommends applying only BMW car wax or products containing carnauba wax or synthetic wax.

Laying up the motorcycle

- Clean the motorcycle.
- Fill the motorcycle's fuel tank.
- Removing battery (👉 187).
- Spray the brake and clutch lever pivots and the main and side stand pivots with a suitable lubricant.

- Preserve bright metal and chrome-plated parts with an acid-free grease (e.g. Vaseline).
- Park the motorcycle in a dry room so that no load applies to either wheel (preferably using the front-wheel and rear-wheel stand available from BMW Motorrad).

Restoring motorcycle to use

- Remove the protective wax coating.
- Clean the motorcycle.
- Installing battery (👉 188).
- Comply with checklist (👉 129).

Technical data

Troubleshooting chart	216
Screw connections	218
Fuel.....	220
Engine oil	221
Engine	221
Clutch	222
Transmission	222
Rear-wheel drive.....	223
Frame	224
Chassis and suspension	224
Brakes	226
Wheels and tyres	227
Electrical system.....	228
Anti-theft alarm	230
Dimensions	230

Weights.....	233
Riding specifications	233

Troubleshooting chart

The engine does not start.

Possible cause	Rectification
Side stand extended and gear engaged	Retract the side stand.
Gear engaged and clutch not disengaged	Select neutral or pull the clutch lever.
No fuel in tank	Refuelling (▣▶ 139).
Battery flat	Charge battery when connected (▣▶ 186).
Overheating protection for starter motor has been activated. Starter motor can only be operated for a limited period of time.	Allow the starter motor to cool down for approx. 1 minute before using it again.

The Bluetooth connection is not established.

Possible cause	Rectification
The steps required for pairing were not carried out.	Check the necessary steps for pairing in the operating instructions for the communication system.
The communication system was not connected automatically despite successful pairing.	Switch off the helmet's communication system and reconnect it after a minute or two.
Too many Bluetooth devices are saved on the helmet.	All pairing entries on the helmet are deleted (see the communication system operating instructions).
There are other vehicles with Bluetooth-capable devices in the vicinity.	Avoid simultaneously pairing with more vehicles.

Bluetooth connection is interrupted.

Possible cause**Rectification**

The Bluetooth connection to the mobile end device is interrupted.

Switch off energy saving mode.

The Bluetooth connection to the helmet is interrupted.

Switch off the helmet's communication system and reconnect it after a minute or two.

The volume in the helmet cannot be adjusted.

Switch off the helmet's communication system and reconnect it after a minute or two.

The telephone book is not displayed in the TFT display.

Possible cause**Rectification**

The phone book was not transmitted to the vehicle.

When pairing the mobile end device, confirm transmission of the phone data (📶➡ 116).

Active route guidance is not displayed in the TFT display.

Possible cause**Rectification**

Navigation from the BMW Motorrad Connected App was not transmitted.

The BMW Motorrad Connected App is opened on the connected mobile end device prior to departure.

The route guidance cannot be started.

Secure the mobile device's data connection and check the map data on the mobile end device.

Screw connections

Front wheel	Value	Valid
Quick-release axle in telescopic forks		
M12 x 20	30 Nm	
Clamping screw for quick-release axle in telescopic fork		
M8 x 35	19 Nm	
Brake caliper on telescopic fork		
M10 x 65	38 Nm	
Wheel-speed sensor to fork leg		
M6 x 16 Micro-encapsulated	8 Nm	
Rear wheel	Value	Valid
Rear wheel to wheel flange		
M10 x 1.25 x 40	Tightening sequence: tighten in diagonally opposite sequence	
	60 Nm	

Mirrors	Value	Valid
Mirror (locknut) to adapter		
M10 x 1.25	Left-hand thread, 22 Nm	
Adapter to clamping block		
M10 x 14 - 4.8	25 Nm	
Handlebars	Value	Valid
Clamping block (handlebar clamp) on fork bridge		
M8 x 35	Tightening sequence: Tighten in riding direction at the front of the block	
	19 Nm	

Fuel

Recommended fuel grade	Super unleaded (max 10% ethanol, E10) 95 ROZ/RON 89 AKI
Alternative fuel grade	Regular unleaded (power and consumption-related restrictions.) (max. 10 % ethanol, E10) 91 ROZ/RON 87 AKI
Usable fuel capacity	approx. 20 l
Reserve fuel	approx. 4 l
Exhaust emissions standard	Euro 4

Engine oil

Engine oil, capacity	max 4 l, with filter change
Specification	SAE 5W-40, API SL / JASO MA2, Additives (e.g. molybdenum-based) are not permissible because they can attack coated components of the engine, BMW Motorrad recommends BMW Motorrad ADVANTEC Ultimate oil.
Engine oil, quantity for topping up	max 0.95 l, Difference between MIN and MAX

BMW recommends **ADVANTEC**
ORIGINAL BMW ENGINE OIL

Engine

Location of engine number	Crankcase, bottom right, below starter motor
Engine type	122EN
Engine design	Air/liquid-cooled two-cylinder, four-stroke, opposed-twin engine with two overhead spur gear-driven camshafts and a counterbalance shaft.
Displacement	1170 cm ³
Cylinder bore	101 mm
Piston stroke	73 mm
Compression ratio	12.5:1

Nominal output	92 kW, at engine speed: 7750 min ⁻¹
– with reduction of power ^{OE}	79 kW, at engine speed: 7750 min ⁻¹
Torque	125 Nm, at engine speed: 6500 min ⁻¹
– with reduction of power ^{OE}	122 Nm, at engine speed: 5250 min ⁻¹
Maximum engine speed	max 9000 min ⁻¹
Idle speed	1150 min ⁻¹ , Engine at regular operating temperature

Clutch

Clutch type	Multiplate oil-bath clutch, anti-hopping
-------------	--

Transmission

Gearbox type	Claw-shift 6-speed gearbox with helical gearing
--------------	---

Gearbox transmission ratios	1.000 (60:60 teeth), Primary transmission ratio 1.650 (33:20 teeth), Transmission input ratio 2.438 (39:16 teeth), 1st gear 1.714 (36:21 teeth), 2nd gear 1.296 (35:27 teeth), 3rd gear 1.059 (36:34 teeth), 4th gear 0.943 (33:35 teeth), 5th gear 0.848 (28:33 teeth), 6th gear 1.061 (35:33 teeth), Transmission output ratio
-----------------------------	--

Rear-wheel drive

Type of final drive	Shaft drive with bevel gears
Type of rear suspension	Cast aluminium single swinging arm featuring BMW Motorrad Paralever
Gear ratio of final drive	2.91 (32/11 teeth)

Frame

Frame type	Tubular steel frame with supporting drive unit, steel pipe rear frames
Type plate location	Frame, front left at steering head
Position of the Vehicle Identification Number	Frame, front right, on steering head

Chassis and suspension

Front wheel

Type of front suspension	BMW Telelever, with anti-dive top fork bridge, leading link pivot-mounted on engine and telescopic forks, central spring strut supported by leading link and frame
Design of front wheel suspension	Central shock absorber with helical spring
– with Dynamic ESA ^{OE}	Central shock absorber complete with torsion spring and header tank, electrically adjustable decompression and compression-stage damping
Spring travel, front	190 mm, at wheel
– with style 1 ^{OE}	210 mm, at wheel
– with sport suspension ^{OE}	
– with lowered suspension ^{OE}	158 mm, at wheel

Rear wheel	
Type of rear suspension	Cast aluminium single swinging arm featuring BMW Motorrad Paralever
Type of rear suspension	Central spring strut with coil spring, adjustable rebound stage damping and spring preload
– with Dynamic ESA ^{OE}	Central spring strut with coil spring and reservoir, electrically adjustable rebound-stage and compression-stage damping, electrically adjustable spring preload
Spring travel at rear wheel	200 mm
– with style 1 ^{OE}	220 mm
– with sport suspension ^{OE}	
– with lowered suspension ^{OE}	170 mm

Brakes

Front wheel

Type of front brake	Hydraulically actuated twin-disc brake with 4-piston radial monobloc calipers and floating brake discs
Brake-pad material, front	Sintered metal
Play of brake controls (Front brake)	approx. 1.85 mm, at piston

Rear wheel

Type of rear brake	Hydraulically actuated disc brake with 2-piston floating caliper and fixed disc
Brake-pad material, rear	Sintered metal
Blow-by clearance of the footbrake lever	1...1.5 mm, between the frame and the footbrake lever

Wheels and tyres

Recommended tyre sets	An overview of currently approved tyres is available from your authorised BMW Motorrad Retailer or on the Internet at bmw-motorrad.com .
Speed category, front/rear tyres	V, required at least: 240 km/h
Front wheel	
Front wheel type	Aluminium cast wheel
– with cross-spoked wheels ^{OE}	cross-spoked wheel
Front wheel rim size	3.00" x 19"
Tyre designation, front	120/70 R 19
Load index, front tyre	min. 60
Permissible front-wheel imbalance	max 5 g
Rear wheel	
Rear-wheel type	Aluminium cast wheel
– with cross-spoked wheels ^{OE}	cross-spoked wheel
Rear wheel rim size	4.50" x 17"
Tyre designation, rear	170/60 R 17
Load index, rear tyre	min. 72
Permissible rear-wheel imbalance	max 45 g

Tyre pressures

Tyre pressure, front	2.5 bar, tyre cold
Tyre pressure, rear	2.9 bar, tyre cold

Electrical system

Electrical rating of on-board sockets	max 5 A, total for all sockets
Fuse carrier 1	10 A, Slot 1: Instrument cluster, anti-theft alarm (DWA), ignition lock, diagnostic socket 7.5 A, Slot 2: Left multifunction switch, tyre pressure monitoring (RDC)
Fuse holder	50 A, Fuse 1: Voltage regulator

Battery

Battery type	AGM (Absorbent Glass Mat) battery
Battery rated voltage	12 V
Battery rated capacity	12 Ah

Spark plugs

Spark plugs, manufacturer and designation	NGK LMAR8D-J
Electrode gap of spark plug	0.8 ^{±0.1} mm, when new 1.0 mm, Wear limit

Lighting

Bulb for high-beam headlight	H7 / 12 V / 55 W
– with LED headlight ^{OE}	LED
Bulbs for the low-beam headlight	H7 / 12 V / 55 W
– with LED headlight ^{OE}	LED
Bulb for parking light	W5W / 12 V / 5 W
– with LED headlight ^{OE}	LED
Bulb for tail light/brake light	LED
Bulbs for flashing turn indicators, front	RY10W / 12 V / 10 W
– with LED flashing turn indicators ^{OE}	LED
Bulbs for flashing turn indicators, rear	RY10W / 12 V / 10 W
– with LED flashing turn indicators ^{OE}	LED

Anti-theft alarm

Activation time on arming	approx. 30 s
Alarm duration	approx. 26 s
Battery type	CR 123 A

Dimensions

Length of motorcycle	2207 mm, via spray guard
Height of motorcycle	1430...1490 mm, via windscreen at DIN unladen weight
– with style 1 ^{OE}	1312...1372 mm, via windscreen at DIN unladen weight
– with style 1 ^{OE} – with sport suspension ^{OE}	1332...1392 mm, via windscreen at DIN unladen weight
– with style 1 ^{OE} – with sport suspension ^{OE} – with passenger package ^{OE}	1450...1510 mm, via windscreen at DIN unladen weight
– with lowered suspension ^{OE}	1405...1465 mm, via windscreen, lower position at DIN unladen weight
Width of motorcycle	952 mm, with mirrors

Front-seat height	850...870 mm, without rider at unladen weight
– with comfort seat ^{OE}	825...845 mm, without rider at unladen weight
– with comfort seat, high ^{OE}	850...870 mm, without rider at unladen weight
– with low rider's seat ^{OE}	820...840 mm, without rider at unladen weight
– with style 1 ^{OE}	860 mm, without rider at unladen weight
– with style 1 ^{OE}	880 mm, without rider at unladen weight
– with motorcycle seat, extra high ^{OE}	
– with style 1 ^{OE}	850...870 mm, without rider at unladen weight
– with passenger package ^{OE}	
– with style 1 ^{OE}	880 mm, without rider at unladen weight
– with sport suspension ^{OE}	
– with style 1 ^{OE}	900 mm, without rider at unladen weight
– with sport suspension ^{OE}	
– with motorcycle seat, extra high ^{OE}	
– with style 1 ^{OE}	870...890 mm, without rider at unladen weight
– with sport suspension ^{OE}	
– with passenger package ^{OE}	
– with lowered suspension ^{OE}	800...820 mm, without rider at unladen weight
Rider's inside-leg arc, heel to heel	1870...1910 mm, without rider at unladen weight
– with comfort seat ^{OE}	1880...1900 mm, without rider at unladen weight
– with comfort seat, high ^{OE}	1920...1940 mm, without rider at unladen weight

– with low rider's seat ^{OE}	1820...1860 mm, without rider at unladen weight
– with style 1 ^{OE}	1880 mm, without rider at unladen weight
– with style 1 ^{OE} – with motorcycle seat, extra high ^{OE}	1920 mm, without rider at unladen weight
– with style 1 ^{OE} – with passenger package ^{OE}	1870...1910 mm, without rider at unladen weight
– with style 1 ^{OE} – with sport suspension ^{OE}	1920 mm, without rider at unladen weight
– with style 1 ^{OE} – with sport suspension ^{OE} – with motorcycle seat, extra high ^{OE}	1960 mm, without rider at unladen weight
– with style 1 ^{OE} – with sport suspension ^{OE} – with passenger package ^{OE}	1910...1950 mm, without rider at unladen weight
– with lowered suspension ^{OE}	1790...1830 mm, without rider at unladen weight

Weights

Vehicle kerb weight	244 kg, DIN unladen weight, ready for road 90 % load of fuel, without OE
Permissible gross weight	460 kg
Maximum payload	216 kg

Riding specifications

Top speed	>200 km/h
-----------	-----------

Service

BMW Motorrad Service	236
BMW Motorrad Mobility services	236
Maintenance work	236
BMW Service	237
Maintenance schedule	239
Maintenance confirmations	240
Service confirmations	254

BMW Motorrad Service

BMW Motorrad has an extensive network of dealerships in place to look after you and your motorcycle in more than 100 countries. Authorised BMW Motorrad dealerships have the technical information and the technical know-how to carry out reliably all maintenance and repair work on your BMW.

You can locate your nearest authorised BMW Motorrad dealership by visiting our website:

bmw-motorrad.com



WARNING

Maintenance and repair work not in compliance with correct procedure

Risk of accident due to consequential damage

- BMW Motorrad recommends having work of this nature carried out on the vehicle by a

specialist workshop, preferably an authorised BMW Motorrad dealer. ◀

In order to help ensure that your BMW is always in optimum condition, BMW Motorrad recommends compliance with the maintenance intervals specified for your motorcycle. Have all maintenance and repair work that is carried out confirmed in the "Service" chapter in this manual. For generous treatment of claims submitted after the warranty period has expired, evidence of regular maintenance is essential.

Your authorised BMW Motorrad dealer can provide information on BMW services and the work undertaken as part of each service.

BMW Motorrad Mobility services

As owner of a new BMW motorcycle, in circumstances in which assistance is required you can benefit from the protection afforded by the various BMW Motorrad mobility services (e.g. Mobile Service, breakdown service, vehicle recovery service). Your authorised BMW Motorrad dealer will be happy provide information about the mobility services available to you.

Maintenance work

BMW Pre-delivery Check

Your authorised BMW Motorrad dealer conducts the BMW pre-delivery check before handing over the vehicle to you.

BMW Running-in Check

The BMW running-in check has to be performed when the motorcycle has covered between 500 km and 1200 km.

BMW Service

The BMW Service is carried out once a year; the extent of servicing can vary, depending on the age of the vehicle and the distance it has covered. Your authorised BMW Motorrad dealer confirms that the service work has been carried out and enters the date when the next service will be due.

Riders who cover long distances in a year might have to bring in their vehicles for service before the next scheduled date. It is to allow for these cases that a maximum odometer reading is entered as well in the confirmation of service. Servicing has to be brought forward if this odo-

meter reading is reached before the next scheduled date for the service.

The service-due indicator in the TFT display reminds you about one month or 1000 km in advance when the time for a service is approaching, on the basis of the programmed values.

To find out more about service go to:

bmw-motorrad.com/service

The maintenance tasks necessary for your vehicle are set out in the maintenance schedule below:

Maintenance schedule

- 1** BMW running-in check (including oil change)
- 2** BMW Service standard scope
- 3** Engine-oil change, with filter
- 4** Oil change in bevel gears rear
- 5** Check valve clearance
- 6** Replace all spark plugs
- 7** Replace air filter element
- 8** Check or replace air-filter element
- 9** Change brake fluid, entire system
 - a annually or every 10000 km (whichever comes first)
 - b every 2 years or every 20000 km (whichever comes first)
 - c if vehicle is used off-road, annually or every 10000 km (whichever comes first)
 - d for the first time after one year, then every two years

Maintenance confirmations

BMW Service standard scope

The repair tasks in the BMW Service standard scope are listed below. The actual scope of maintenance work applicable for your vehicle may vary.

- Performing vehicle test with BMW Motorrad diagnostic system
- Visual inspection of hydraulic clutch system
- Visually inspecting brake pipes, brake hoses and connections
- Checking front brake pads and brake discs for wear
- Checking brake-fluid level, front brakes
- Checking rear brake pads and brake disc for wear
- Checking brake-fluid level, rear brakes
- Checking coolant level
- Checking ease of movement of side stand
- Checking ease of movement of centre stand
- Checking tyre tread depth and tyre pressure
- Checking spoke tension, adjusting if necessary
- Check the lights and signalling equipment
- Function test, engine start suppression
- Final inspection and check for road safety
- Set the service-due date and service countdown distance
- Checking battery charge state
- Confirming the BMW service in the on-board literature

BMW pre-delivery check

carried out

at _____

Stamp, signature

BMW Running-in Check

carried out

at _____

at km _____

Next service

at the latest

at _____

or, when reached earlier

at km _____

Stamp, signature

BMW Service

carried out

at _____

at km _____

Next service

at the latest

at _____

or, when reached earlier

at km _____

Work performed

BMW Service

Yes

No

Oil change, engine, with filter

Oil change in rear bevel gears

Checking valve clearance

Renewing all spark plugs

Renewing air cleaner insert

Checking or replacing air filter element
(for maintenance)

Change brake fluid in entire system

Notes

Stamp, signature

BMW Service

carried out

at _____

at km _____

Next service

at the latest

at _____

or, when reached earlier

at km _____

Stamp, signature

Work performed

BMW Service

Oil change, engine, with filter

Oil change in rear bevel gears

Checking valve clearance

Renewing all spark plugs

Renewing air cleaner insert

Checking or replacing air filter element

(for maintenance)

Change brake fluid in entire system

Yes No

Notes

BMW Service

carried out

at _____

at km _____

Next service

at the latest

at _____

or, when reached earlier

at km _____

Work performed

BMW Service

Yes

No

Oil change, engine, with filter

Oil change in rear bevel gears

Checking valve clearance

Renewing all spark plugs

Renewing air cleaner insert

Checking or replacing air filter element
(for maintenance)

Change brake fluid in entire system

Notes

Stamp, signature

BMW Service

carried out

at _____

at km _____

Next service

at the latest

at _____

or, when reached earlier

at km _____

Stamp, signature

Work performed

BMW Service

Oil change, engine, with filter

Oil change in rear bevel gears

Checking valve clearance

Renewing all spark plugs

Renewing air cleaner insert

Checking or replacing air filter element

(for maintenance)

Change brake fluid in entire system

Yes No

Notes

BMW Service

carried out

at _____

at km _____

Next service

at the latest

at _____

or, when reached earlier

at km _____

Work performed

BMW Service

Yes

No

Oil change, engine, with filter

Oil change in rear bevel gears

Checking valve clearance

Renewing all spark plugs

Renewing air cleaner insert

Checking or replacing air filter element
(for maintenance)

Change brake fluid in entire system

Notes

Stamp, signature

BMW Service

carried out

at _____

at km _____

Next service

at the latest

at _____

or, when reached earlier

at km _____

Stamp, signature

Work performed

BMW Service

Yes

No

Oil change, engine, with filter

Oil change in rear bevel gears

Checking valve clearance

Renewing all spark plugs

Renewing air cleaner insert

Checking or replacing air filter element
(for maintenance)

Change brake fluid in entire system

Notes

BMW Service

carried out

at _____

at km _____

Next service

at the latest

at _____

or, when reached earlier

at km _____

Work performed

BMW Service

Yes

No

Oil change, engine, with filter

Oil change in rear bevel gears

Checking valve clearance

Renewing all spark plugs

Renewing air cleaner insert

Checking or replacing air filter element
(for maintenance)

Change brake fluid in entire system

Notes

Stamp, signature

BMW Service

carried out

at _____

at km _____

Next service

at the latest

at _____

or, when reached earlier

at km _____

Stamp, signature

Work performed

BMW Service

Oil change, engine, with filter

Oil change in rear bevel gears

Checking valve clearance

Renewing all spark plugs

Renewing air cleaner insert

Checking or replacing air filter element

(for maintenance)

Change brake fluid in entire system

Yes No

Notes

BMW Service

carried out

at _____

at km _____

Next service

at the latest

at _____

or, when reached earlier

at km _____

Work performed

BMW Service

Yes

No

Oil change, engine, with filter

Oil change in rear bevel gears

Checking valve clearance

Renewing all spark plugs

Renewing air cleaner insert

Checking or replacing air filter element
(for maintenance)

Change brake fluid in entire system

Notes

Stamp, signature

BMW Service

carried out

at _____

at km _____

Next service

at the latest

at _____

or, when reached earlier

at km _____

Stamp, signature

Work performed

BMW Service

Oil change, engine, with filter

Oil change in rear bevel gears

Checking valve clearance

Renewing all spark plugs

Renewing air cleaner insert

Checking or replacing air filter element

(for maintenance)

Change brake fluid in entire system

Yes No

Notes

BMW Service

carried out

at _____

at km _____

Next service

at the latest

at _____

or, when reached earlier

at km _____

Work performed

BMW Service

Yes

No

Oil change, engine, with filter

Oil change in rear bevel gears

Checking valve clearance

Renewing all spark plugs

Renewing air cleaner insert

Checking or replacing air filter element
(for maintenance)

Change brake fluid in entire system

Notes

Stamp, signature

BMW Service

carried out

at _____

at km _____

Next service

at the latest

at _____

or, when reached earlier

at km _____

Stamp, signature

Work performed

BMW Service

Oil change, engine, with filter

Oil change in rear bevel gears

Checking valve clearance

Renewing all spark plugs

Renewing air cleaner insert

Checking or replacing air filter element

(for maintenance)

Change brake fluid in entire system

Yes

No

Notes

Appendix

Certificate for Electronic Immobiliser	258
Certificate for Keyless Ride	260
Certificate for Tyre Pressure Control (RDC)	262
Certificate for TFT instrument cluster	263

FCC Approval

Ring aerial in the ignition switch



To verify the authorization of the ignition key, the electronic immobilizer exchanges information with the ignition key via the ring aerial.

This device complies with Part 15 of the FCC rules. Operation is subject to the following two conditions:

- (1) This device may not cause harmful interference, and
- (2) this device must accept any interference received, including interference that may cause undesired operation.



Any changes or modifications not expressly approved by the party responsible for compliance could void the user's authority to operate the equipment. ◀

Approbation de la FCC

Antenne annulaire présente dans le commutateur d'allumage



Pour vérifier l'autorisation de la clé de contact, le système d'immobilisation électronique échange des

informations avec la clé de contact via l'antenne annulaire.

Le présent dispositif est conforme à la partie 15 des règles de la FCC. Son utilisation est soumise aux deux conditions suivantes :

- (1) Le dispositif ne doit pas produire d'interférences nuisibles, et
- (2) le dispositif doit pouvoir accepter toutes les interférences extérieures, y compris celles qui pourraient provoquer une activation inopportune.



Toute modification qui n'aurait pas été approuvée expressément par l'organisme responsable de l'homologation peut annuler l'autorisation accordée à l'utilisateur pour utiliser le dispositif. ◀

Certifications

BMW Keyless Ride ID Device



USA, Canada

Product name: BMW Keyless Ride ID Device
FCC ID: YGOHUF5750
IC: 4008C-HUF5750

Canada:

Operation is subject to the following two conditions:

- (1) This device may not cause harmful interference, and
- (2) this device must accept any interference received, including interference that may cause undesired operation.

USA:

This device complies with Part 15 of the FCC rules. Operation is subject to the following two conditions:

- (1) This device may not cause harmful interference, and
- (2) this device must accept any interference received, including interference that may cause undesired operation.



Any changes or modifications not expressly approved by the party responsible for compliance could void the user's authority to operate the equipment.

Declaration Of Conformity

We declare under our responsibility that the product

BMW Keyless Ride ID Device (Model: HUF5750)

complies with the appropriate essential requirements of the article 3 of the R&TIE and the other relevant provisions, when used for its intended purpose. Applied Standards:

1. Health and safety requirements contained in article 3 (1) a)
 - EN 60950-1:2006+A11:2009+A1:2010+A12:2011; Information technology equipment- Safety
2. Protection requirements with respect to electromagnetic compatibility article 3 (1) b)
 - EN 301 489-1 (V1.9.2, 09/2011), Electromagnetic compatibility and radio spectrum matters (ERM); Electromagnetic compatibility (EMC) standard for radio equipment and services; Part 1: Common technical requirements
 - EN 301 489-3 (V1.4.1, 08/2002) Electromagnetic compatibility and radio spectrum matters (ERM); Electromagnetic compatibility (EMC) standard for radio equipment and services; Part 3: Specific conditions for short range devices (SRD) operating on frequencies between 9 kHz and 40 GHz
3. Means of the efficient use of the radio frequency spectrum article 3 (2)
 - EN 300 220-1 & -2 (V2.4.1, 05/2012), electromagnetic compatibility and radio spectrum matters (ERM); Short range devices (SRD); Radio equipment to be used in the 25 MHz to 1000 MHz frequency range with power levels ranging up to 500 mW;
Part 1: Technical characteristics and test methods.
Part 2: Harmonized EN covering essential requirements under article 3.2 of the R&TIE directive

The product is labeled with the CE marking: **CE**

Velbert, October 15th, 2013



Benjamin A. Müller
Product Development Systems
Car Access and Immobilization – Electronics
Huf Hülbeck & Fürst GmbH & Co. KG
Steeger Straße 17, D-42551 Velbert

Certification Tire Pressure Control (TPC)

FCC ID: MRXBC54MA4
IC: 2546A-BC54MA4

FCC ID: MRXBC5A4
IC: 2546A-BC5A4

This device complies with Part 15 of the FCC Rules and with Industry Canada license-exempt RSS standard(s).

Operation is subject to the following two conditions:

- (1) This device may not cause harmful interference, and
- (2) This device must accept any interference received, including interference that may cause undesired operation.

Le présent appareil est conforme aux CNR d'Industrie Canada applicables aux appareils radio exempts de licence. L'exploitation est autorisée aux deux conditions suivantes:

- (1) l'appareil ne doit pas produire de brouillage, et
- (2) l'utilisateur de l'appareil doit accepter tout brouillage radioélectrique subi, même si le brouillage est susceptible d'en compromettre le fonctionnement.

WARNING: Changes or modifications not expressly approved by the party responsible for compliance could void the user's authority to operate the equipment. The term "IC:" before the radio certification number only signifies that Industry Canada technical specifications were met.

Declaration of Conformity

Radio equipment TFT instrument cluster

For all Countries without EU

Technical information

BT operating frq. Range: 2402 – 2480 MHz

BT version: 4.2 (no BTLE)

BT output power: < 4 dBm

WLAN operating frq. Range: 2412 – 2462 MHz

WLAN standards: IEEE 802.11 b/g/n

WLAN output power: < 20 dBm

Manufacturer and Address

Manufacturer:

Robert Bosch Car Multimedia GmbH

Adress: Robert Bosch Str. 200,

31139 Hildesheim, GERMANY

Turkey

Robert Bosch Car Multimedia GmbH, ICC6.5in tipi telsiz sisteminin 2014/53/EU nolu yönetmeliğe uygun olduğunu beyan eder. AB Uygunluk Beyanı'nın tam metni, aşağıdaki internet adresinden görülebilir: <http://cert.bosch-carmultimedia.net>

Brazil

Este equipamento opera em caráter secundário, isto é, não tem direito a proteção contra interferência prejudicial, mesmo de estações do mesmo tipo, e não pode causar interferência a sistemas operando em caráter primário.

Canada

This device complies with Industry Canada's licence-exempt RSSs and part 15 of the FCC Rules. Operation is subject to the following two conditions:

(1) this device may not cause interference, and
(2) this device must accept any interference, including interference that may cause undesired operation of the device.

Changes or modifications not expressly approved by the party responsible for compliance could void the user's authority to operate the equipment.

Le présent appareil est conforme aux CNR d'Industrie Canada applicables aux appareils radio exempts de licence. L'exploitation est autorisée aux deux conditions suivantes : (1) l'appareil ne doit pas produire de brouillage, et (2) l'appareil doit accepter tout brouillage radioélectrique subi, même si le brouillage est susceptible d'en compromettre le fonctionnement.

Mexico

La operación de este equipo está sujeta a las siguientes dos condiciones:

(1) es posible que este equipo o dispositivo no cause interferencia perjudicial y
(2) este equipo o dispositivo debe aceptar cualquier interferencia, incluyendo la que pueda causar su operación no deseada.

Taiwan, Republic of

根據 NCC 低功率電波輻射性電機管理辦法 規定：
第十二條

經型式認證合格之低功率射頻電機，非經許可，公司、商號或使用者均不得擅自變更頻率、加大功率或變更原設計之特性及功能。

第十四條

低功率射頻電機之使用不得影響飛航安全及干擾合法通信；經發現有干擾現象時，應立即停用，並改善至無干擾時方得繼續使用。

前項合法通信，

指依電信法規定作業之無線電通信。

低功率射頻電機須忍受合法通信或工業、科學及醫療用電波輻射性電機設備之干擾。

Thailand

เครื่องโทรคมนาคมและอุปกรณ์นี้

มีความสอดคล้องตามข้อกำหนดของ กททช.

(This telecommunication equipments is in compliance with NTC requirements)

United States (USA)

This device complies with Industry Canada's licence-exempt RSSs and part 15 of the FCC Rules. Operation is subject to the following two conditions:

(1) this device may not cause interference, and
(2) this device must accept any interference, including interference that may cause undesired operation of the device.

Changes or modifications not expressly approved by the party responsible for compliance could void the user's authority to operate the equipment.

Le présent appareil est conforme aux CNR d'Industrie Canada applicables aux appareils radio exempts de licence. L'exploitation est autorisée aux deux conditions suivantes : (1) l'appareil ne doit pas produire de brouillage, et (2) l'appareil doit accepter tout brouillage radioélectrique subi, même si le brouillage est susceptible d'en compromettre le fonctionnement.

- A**
Abbreviations and symbols, 6
ABS
 Control, 15
 Engineering details, 146
 operate, 70
 Self-diagnosis, 130
 Status indicators, 47
Accessories
 General instructions, 194
Actuality, 7
Air filter
 Position on the motorcycle, 13
 Replacing the air filter element, 177
Ambient temperature
 Outside temperature warning, 36
 Reading, 36
Anti-theft alarm
 Indicator light, 18
 operate, 86
 Technical data, 230
 Warning, 40
- ASC
 Control, 15
 Engineering details, 150
 operate, 71
 Reading, 48
 Self-diagnosis, 131
- B**
Battery
 Charge battery when connected, 186
 Charging battery when disconnected, 187
 Indicator light for vehicle voltage, 37, 38
 install, 188
 Maintenance instructions, 185
 Removal, 187
 Technical data, 228
Bluetooth, 106
 Pairing, 107
- Brake fluid
 Checking fluid level, front, 166
 Checking fluid level, rear, 167
 Reservoir, front, 13
 Reservoir, rear, 13
Brake pads
 Checking front, 164
 checking rear, 165
 Running in, 133
Brakes
 ABS Pro in detail, 148
 ABS Pro depending on riding mode, 137
 Adjusting handlebar lever, 120
 Checking function, 163
 Safety instructions, 136
 Technical data, 226
- C**
Cases, 195
Check control
 Dialogue box, 25
 Reading, 25
Checklist, 129

Clock
 Adjusting, 105

Clutch
 Adjusting handlebar lever, 120
 Checking function, 168
 Technical data, 222

Coding plug
 install, 81

Coolant
 Checking fill level, 168
 Indicator light for excess temperature, 40
 Topping up, 169

Cruise-control system
 operate, 82

D

Damping
 Adjuster, rear, 11

Daytime riding lights
 automatic daytime riding light, 68
 Manual daytime riding light, 67

Diagnostic connector
 Loosen, 191
 secure, 191

Dimensions
 Technical data, 230

DTC
 Engineering details, 150
 Indicator and warning light , 49
 operate, 73
 Self-diagnosis, 132
 switching off, 73
 switching on, 74

E

Electrics
 Technical data, 228

Emergency call
 Automatically in the event of a light fall, 64
 Automatically in the event of a severe fall, 65
 Language, 63
 manual, 63
 operate, 63

Emergency off switch (kill switch), 17
 Operation, 62

Emissions warning light, 41

Engine
 Indicator light for engine control, 42
 Indicator light for engine electronics, 41
 Malfunction indicator lamp, 41
 starting, 129
 Technical data, 221

Engine oil
 Checking fill level, 162
 Electronic oil-level check, 40
 Filling level indicator, 13
 Indicator light for engine oil level, 40
 Oil filler opening, 13
 Technical data, 221
 Topping up, 163

Equipment, 7

ESA
 Control, 15
 operate, 75

F

Frame
 Technical data, 224

Front-wheel stand
Installing, 161

Fuel
Oil filler opening, 11
refuelling, 139
refuelling with Keyless
Ride, 140, 141
Technical data, 220

Fuel reserve
Range, 104
Warning, 51

Fuses
replacing, 189

G

General views
Indicator and warning lights, 20
Instrument panel, 18
Left multifunction switch, 15
Left side of vehicle, 11
My Vehicle, 110
Right multifunction switch, 17
Right side of vehicle, 13
TFT display, 22, 24
Underneath the seat, 14

H

Handlebars
Adjusting, 121
Hazard warning flashers
Control, 15, 17
operate, 69
Headlight
Beam throw, 118
Headlight beam-throw
adjustment, 11
Headlight courtesy delay
feature, 56, 66
Heated handlebar grips
Control, 17
operate, 89
Hill Start Control, 85, 157
cannot be activated, 52
Engineering details, 157
Indicator and warning lights, 51,
52
operate, 85
Horn, 15

I

Ignition
switching off, 57
switching on, 56
Immobiliser
Emergency key, 60
Reserve key, 57
Instrument panel
Ambient-light brightness
sensor, 18
Overview, 18

J

Jump-start, 184

K

Keyless Ride
Battery of the radio-operated
key is flat or the key has been
lost, 60
Electronic immobiliser EWS, 60
Fuel filler cap, unlocking, 140,
141
Lock the handlebars, 58
Switching off ignition, 59
Switching on ignition, 59

Warning, 36, 37
Keys, 56, 58

L

Lighting

High-beam headlight, 179
Low-beam headlight, 179
Replace LED headlights, 184
Replacing LED auxiliary headlights, 184
Replacing LED rear light, 183
Side light, 181
Technical data, 229
Turn indicators, 182
Warning for faulty bulb, 38

Lights

automatic daytime riding light, 68
Control, 15
Headlight courtesy delay feature, 66
Headlight flasher, operating, 65
High-beam headlight, operating, 65
Low-beam headlight, 65

Manual daytime riding light, 67
Operating additional headlights, 66
Parking lights, 66
Side light, 65
Lowered suspension
Restrictions, 126
Luggage
Instructions for loading, 126

M

Maintenance

General instructions, 160
Maintenance schedule, 239
Maintenance confirmations, 240
Maintenance intervals, 236

Media

operate, 115

Menu

Call up, 100

Mirrors

Adjusting, 118

Mobility services, 236

Motorcycle

care, 211
cleaning, 211
Lashing, 142
Laying up, 214
parking, 138
Multifunction switch
General view, left side, 15
General view, right side, 17

N

Navigation

operate, 113

O

Off-roading, 133
On-board computer, 90
On-board voltage
Warning, 37, 38
Operating focus
change, 101

P

Pairing, 107
Parking, 138
Parking light, 66

Phone
operate, 115

Power socket
Notes on use, 194
Position on the vehicle, 13

Pre-Ride-Check, 130

Pure Ride
Overview, 22

R

RDC
Adhesive label for rim, 172
Engineering details, 155
Warnings, 44

Rear-wheel drive
Technical data, 223

Refuelling, 139
with Keyless Ride, 140, 141

Remote control
Replacing battery, 61

Rev. counter, 18
Engine speed display, 103

Rider info status line
Adjusting, 102, 103

Rider's Manual
Position on the vehicle, 14

Riding mode
Adjusting, 78
Control, 17
Engineering details, 152
Setting the PRO riding mode, 80

Riding specifications
Technical data, 233

Running gear
Technical data, 224

Running in, 133

S

Safety instructions
for brakes, 136
for riding, 126

Seat
Position of the height adjustment, 14

Seats
Adjust the seat height, 92
Lock, 11
Removing and installing, 91

Service, 236

Service-due indicator, 53

Shift assistant
Engineering details, 156
Gear not trained, 52
Riding, 135

Shifting gear
Recommendation to upshift, 104

Spark plugs
Technical data, 228

Speed Limit Info
Switching on or off, 103

Speedometer, 18

Spring preload
Adjuster, rear, 13
Adjusting, 121

Starting, 129
Control, 17

Steering lock
Locking, 56

T

Technical data
Anti-theft alarm, 230
Battery, 228
Brakes, 226

- Bulbs, 229
- Chassis and suspension, 224
- Clutch, 222
- Dimensions, 230
- Electrical system, 228
- Engine, 221
- Engine oil, 221
- Frame, 224
- Fuel, 220
- Rear-wheel drive, 223
- Riding specifications, 233
- Spark plugs, 228
- Standards, 7
- Transmission, 222
- Weights, 233
- Wheels and tyres, 227
- Telltale lights, 18
 - Overview, 20
- TFT display, 18
 - Control, 15
 - operate, 100, 101, 102
 - Overview, 22, 24
 - Select display, 97
- Threaded fasteners, 218
- Toolkit
 - Position on the vehicle, 14
- Topcase
 - operate, 198
- Torques, 218
- Traction control
 - ASC, 149, 150
 - DTC, 150
- Transmission
 - Technical data, 222
- Troubleshooting chart, 216
- Turn indicators
 - Control, 15
 - Control, right, 17
 - operate, 69
- Type plate
 - Position on the vehicle, 13
- Tyre pressure monitoring RDC
 - Reading, 43
- Tyres
 - Checking inflation pressure, 170
 - Checking tread depth, 170
 - Pressures, 228
 - Running in, 133

- Table of tyre pressures, 14
- Technical data, 227
- Top speed, 127

V

- Value
 - Reading, 25
- Vehicle
 - Restoring to use, 214
- Vehicle Identification Number
 - Position on the vehicle, 13

W

- Warning lights, 18
 - Overview, 20
- Warnings
 - ABS, 47
 - Anti-theft alarm, 40
 - ASC, 48
 - Bulb faulty, 38
 - Coolant temperature, 40
 - DTC, 49
 - Engine control unit, 42
 - Engine electronics, 41
 - Engine oil level, 40
 - Fuel reserve, 51

- Gear not trained, 52
- Hill Start Control, 51, 52
- Malfunction indicator lamp, 41
- Mode of presentation, 25
- My Vehicle, 110
- On-board voltage, 37, 38
- Outside temperature warning, 36
- RDC, 44
- Warnings, overview, 28
- Weights
 - Payload table, 14
 - Technical data, 233
- Wheels
 - Change of size, 171
 - Checking rims, 170
 - Checking spokes, 171
 - Install the rear wheel, 177
 - Installing front wheel, 174
 - Removing front wheel, 172
 - Technical data, 227
- Windscreen
 - Adjuster, 13
 - Adjusting, 119

Details described or illustrated in this booklet may differ from the vehicle's actual specification as purchased, the accessories fitted or the national-market specification. No claims will be entertained as a result of such discrepancies.

Dimensions, weights, fuel consumption and performance data are quoted to the customary tolerances.

The right to modify designs, equipment and accessories is reserved.

Errors and omissions excepted.

© 2017 Bayerische Motoren Werke Aktiengesellschaft
80788 Munich, Germany
Not to be reproduced by any means whatsoever, wholly or in part, without the written permission of BMW Motorrad, After Sales.

Original rider's manual, printed in Germany.

