



BMW Motorrad



The Ultimate
Riding Machine

Rider's Manual (US Model)

R 1200 GS

Motorcycle/Dealer Data

Motorcycle data

Model

Vehicle identification number

Color number

Initial registration

License plate

Dealer Data

Contact in Service

Ms./Mr.

Phone number

Dealer's address/phone number (company stamp)

Welcome to BMW

Congratulations on choosing a motorcycle from BMW Motorrad and welcome to the community of BMW motorcycle owners and riders. Familiarize yourself with your new motorcycle so that you can ride it safely and confidently in all highway traffic situations.

About this Rider's Manual

Please read this Rider's Manual carefully before starting to use your new BMW. It contains important information on how to operate the controls and how to get the most benefit from your BMW's advanced technical features.

In addition, it contains information on maintenance and care to help you maintain your vehicle's reliability and safety, as well as its value.

Suggestions and complaints

If you have any questions concerning your motorcycle, your authorized BMW Motorrad retailer is always happy to provide advice and assistance.

We wish you many miles of safe and enjoyable riding on your BMW

BMW Motorrad.

01 41 8 554 637



Table of Contents

1 General instructions	5	Warning lamps	24	ASC Automatic Stability Control	57
Overview	6	Outside temperature	37	Riding mode	58
Abbreviations and symbols	6	Fuel reserve	37	Cruise control	61
Equipment	7	Oil level indicator	38	Spring preload	64
Technical data	7	Service display	38	Damping	64
Notice concerning current status	7	Tire inflation pressures	39	Dynamic ESA, Electronic Suspension Adjustment	65
2 Overviews	9	Upshift recommendation	39	Clutch	67
General view, left side	11	4 Operation.....	41	Brakes	68
General view, right side	13	Steering and ignition lock	42	Tires	68
Underneath seat	14	Ignition	43	Handlebars	69
Multifunction switch, left	15	EWS Electronic immobilizer	43	Heated handlebar grips	69
Multifunction switch, right	17	Multifunction display	44	Mirrors	70
Instrument cluster	18	Anti-theft alarm system (DWA)	50	Windshield	71
3 Displays	19	Emergency on/off switch (kill switch)	52	Rider and passenger seats	71
Warning and indicator lamps	20	Headlight	53	5 Riding.....	75
Multifunction display	22	Lights	54	Safety instructions	76
Warning symbols in the display panel	23	Turn indicator	55	Checklist	78
		Hazard warning flashers	55	Starting.....	78
		BMW Motorrad Integral ABS	56	Breaking in	81
				Brakes	82
				Parking your motorcycle	83

Off-road riding	83
Refueling	84
Securing motorcycle for transport	86

6 Technology in detail

89	
Riding mode	90
Brake system with BMW Motorrad Integral ABS	91
Engine management with BMW Motorrad ASC	94
Tire Pressure Control TCP/RDC	95

7 Maintenance

97	
General instructions	98
Onboard tool kit	98
Engine oil	99
Brake system	100
Coolant	104
Clutch	105
Wheel rims and tires	106
Wheels	106
Front wheel stand	112
Bulbs	113

Air filter	118
Jump-starting	119
Battery	120
Fuses	124

8 Accessories

125	
General instructions	126
Onboard power sockets	126
Navigation system	127
Case	131
Topcase	134

9 Care

139	
Care products	140
Washing your motorcycle	140
Cleaning sensitive motorcycle parts	141
Paint care	141
Storing the motorcycle	142
Protective wax coating	142
Returning motorcycle to use	142

10 Technical data

143	
Troubleshooting chart	144
Threaded fasteners	145
Engine	147
Fuel	148
Engine oil	149
Clutch	149
Transmission	150
Rear-wheel drive	151
Suspension	151
Brakes	152
Wheels and tires	153
Electrical system	154
Anti-theft alarm system	155
Frame	155
Dimensions	156
Weights	157
Performance data	157

11 Service

159	
Reporting safety defects	160
BMW Motorrad Service	161
BMW Motorrad Mobility Services	161

Maintenance proce- dures.....	161
Confirmation of mainte- nance work.....	163
Confirmation of service....	168
12 Appendix.....	171
Certificate	172
13 Index	173

General instructions

Overview	6
Abbreviations and symbols	6
Equipment	7
Technical data	7
Notice concerning current status	7

Overview

We have placed great importance on good orientation when using this Rider's Manual. You'll find special topics most quickly by using the extensive index at the end of the manual. You can find a first overview of your motorcycle in Chapter 2. All maintenance and repair work carried out on your vehicle will be documented in Chapter 11. Proof of the maintenance work performed is a prerequisite for generous treatment of claims.

When the time comes to sell your BMW, remember to hand over this Rider's Manual; it is an important part of the motorcycle.

Abbreviations and symbols



Indicates warnings that are imperative to observe for your own safety and the safety of others, and to protect your product against damage.



Special information on operating and inspecting your motorcycle as well as maintenance and adjustment procedures.



Indicates the end of an item of information.



Instruction.



Result of an activity.



Reference to a page with more detailed information.



Indicates the end of accessory or equipment-dependent information.



Tightening torque.



Technical data.

OE

Optional extra. BMW Motorrad optional extras are already completely installed during motorcycle production.

OA

Optional accessory. BMW Motorrad optional accessories can be purchased and installed at your authorized BMW Motorrad retailer.

EWS

Electronic immobilizer.

DWA

Anti-theft alarm.

ABS Anti-Lock Brake System.

ASC Automatic Stability Control.

ESA Electronic Suspension Adjustment.

TPC Tire Pressure Control (TPC).

Equipment

When you ordered your BMW motorcycle, you chose various items of custom equipment. This Rider's Manual describes optional equipment (OE) offered by BMW and selected optional accessories (OA). This explains why the manual may also contain descriptions of equipment which you have not ordered. Please note, too, that your motorcycle might not be exactly as illustrated in this manual on account of country-specific differences.

If your motorcycle comes with equipment not described here, you can find the descriptions in a separate manual.

Technical data

All dimensions, weights and outputs in the Rider's Manual relate to the German DIN standards and comply with their tolerance specifications. Versions for individual countries may differ.

Notice concerning current status

The high safety and quality standards of BMW motorcycles are maintained by constant development work on design, equipment and accessories. Because of this, your motorcycle may differ from the information supplied in the Rider's Manual. In addition, BMW Motorrad cannot guarantee the total absence of errors. We

hope you will appreciate that no claims can be entertained on the basis of the data, illustrations or descriptions in this manual.

Overviews

General view, left side.....	11
General view, right side	13
Underneath seat	14
Multifunction switch, left	15
Multifunction switch, right.....	17
Instrument cluster	18



General view, left side

- 1 Fuel filler opening (▣▣▣▶ 85)
- 2 Seat lock (▣▣▣▶ 71)
- 3 Adjuster for rear damping (at the bottom on the spring strut) (▣▣▣▶ 64)

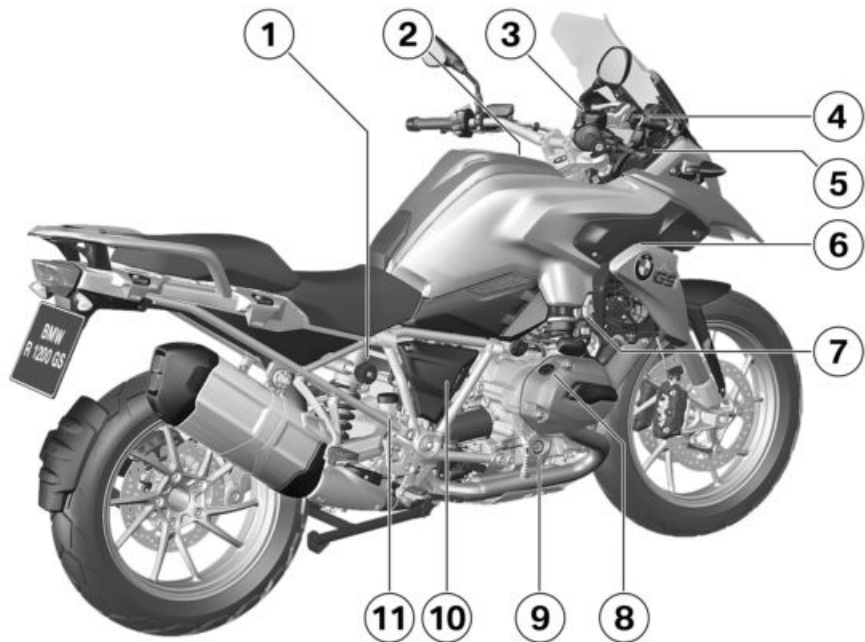

General view, right side

- 1 Adjuster for spring preload, rear (➡ 64)
- 2 Air cleaner (under center fairing panel) (➡ 118)
- 3 Brake-fluid reservoir, front (➡ 102)
- 4 Height adjuster for windshield (➡ 71)
- 5 Onboard power socket (➡ 126)
- 6 Vehicle Identification Number (on steering-head bearing)
Type plate (on frame at front right)
- 7 Coolant level indicator (➡ 104)
Coolant tank (➡ 104)
- 8 Engine oil fill location (➡ 100)
- 9 Engine oil level indicator (➡ 99)
- 10 Battery (behind side panel) (➡ 120)
Auxiliary terminal for jump starting (behind side panel) (➡ 119)
- 11 Brake-fluid reservoir, rear (➡ 103)

Underneath seat

- 1 Standard tool kit (►► 98)
- 2 Rider's Manual (US Model)
- 3 Tire inflation pressure table
- 4 Payload table
- 5 Adjuster for the rider's seat height (►► 72)
- 6 Fuses (►► 124)

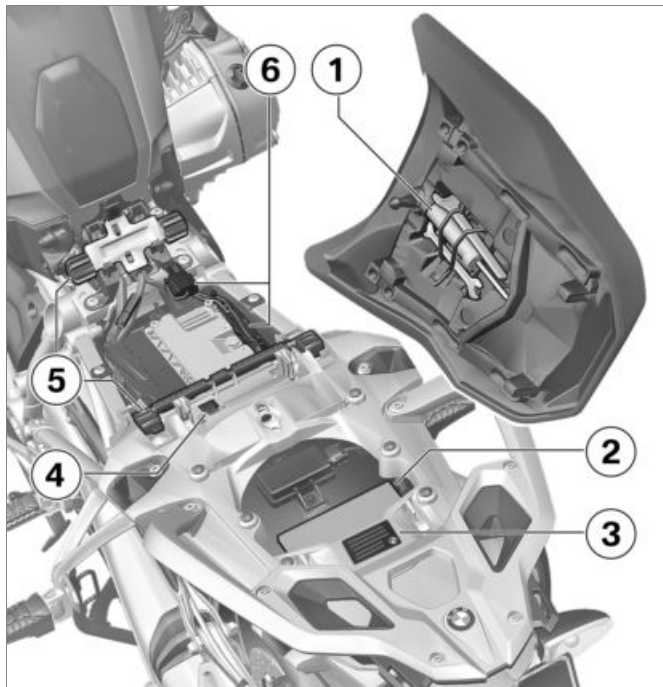

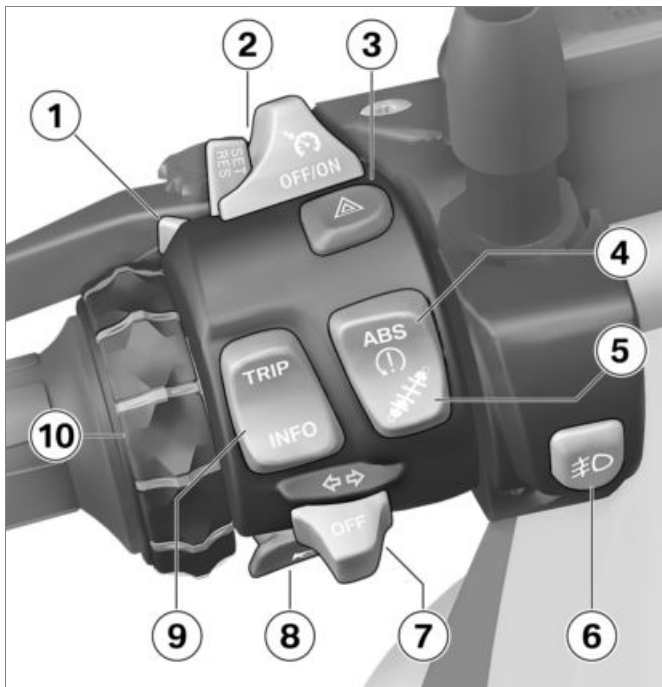

Multifunction switch, left

- 1 Headlight flasher and high-beam headlight (➡ 54)
- 2 – with cruise control^{OE}
Switch on cruise control (➡ 61).
- 3 Hazard warning flashers (➡ 55)
- 4 ABS (➡ 56)
ASC (➡ 57)
- 5 – with dynamic ESA^{OE}
Adjustment options (➡ 65)
- 6 – with additional LED headlight^{OA}
Auxiliary headlight (➡ 54).
- 7 Turn indicators (➡ 55)
- 8 Horn
- 9 Multifunction display (➡ 44)

- 10** – with preparation for navigation system^{OE}
Operating the navigation system (▣▶ 128)



Multifunction switch, right

- 1 – with heated handlebar grips^{OE}
Heated handlebar grips (➡ 69)
- 2 Riding mode (➡ 58)
- 3 Emergency on/off switch (kill switch) (➡ 52)
- 4 Starting the engine (➡ 78)

Instrument cluster

- 1 Speedometer
- 2 Tachometer
- 3 Ambient light sensor (for brightness adjustment of instrument lighting)
– with anti-theft alarm^{OE}
- 4 Warning and indicator lamps (☰➔ 20)
- 5 Multifunction display (☰➔ 22)

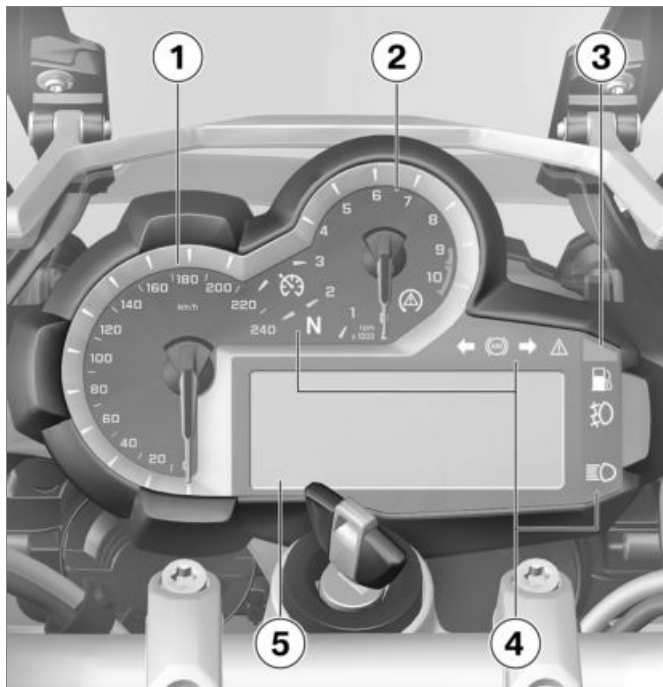

Displays

Warning and indicator lamps	20
Multifunction display	22
Warning symbols in the display panel	23
Warning lamps	24
Outside temperature	37
Fuel reserve	37
Oil level indicator	38
Service display	38
Tire inflation pressures	39
Upshift recommendation	39

Warning and indicator lamps

- 1 – with cruise control^{OE}
Switch on cruise control (►► 61).
- 2 Idle
- 3 Deactivate ASC function (►► 57).
- 4 Turn indicator, left
- 5 ABS (►► 56)
- 6 Turn indicator, right
- 7 General warning lamp, appears together with warning symbols in display panel (►► 24)
- 8 DWA
- 9 High-beam headlight (►► 54)
- 10 – with additional LED headlight^{OA}
Auxiliary headlight (►► 54).
- 11 Fuel reserve (►► 37)

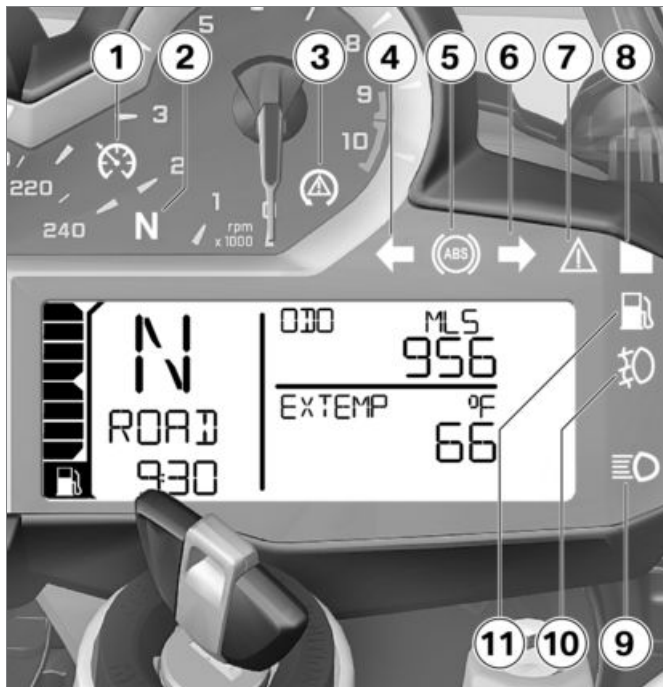

▶ The ABS symbol can be shown differently depending on the country. ◀

Multifunction display

- 1 Fuel fill level indicator
- 2 Upshift recommendation (►►► 39)
- 3 Gear indicator display, "N" indicates "neutral."
- 4 – with heated handlebar grips
Operate heated grips (►►► 69).
- 5 Odometer (►►► 44)
- 6 Service display (maintenance interval) (►►► 161)
- 7 Warning symbols (►►► 24)
- 8 Onboard computer
- 9 – with dynamic ESA^{OE}
Adjustment options (►►► 65)
- 10 Use of the riding modes (►►► 58)
- 11 Clock (►►► 47)
- 12 Outside temperature warning (►►► 37)

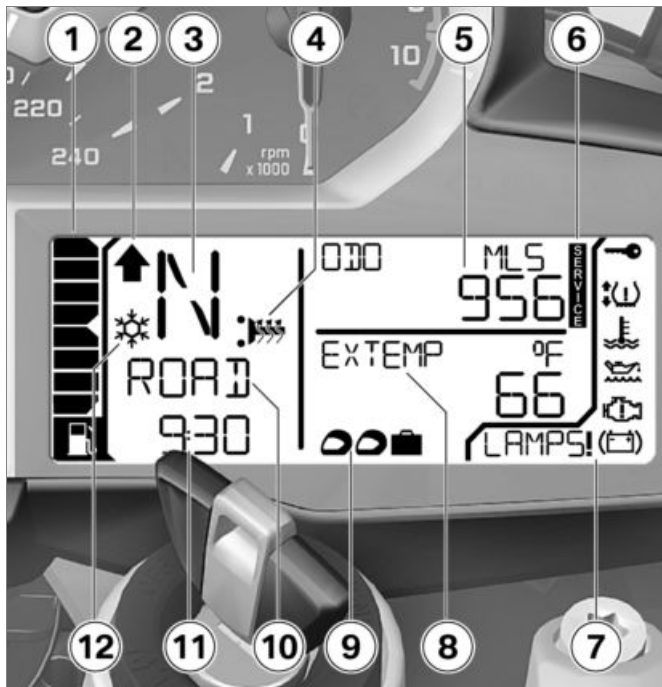

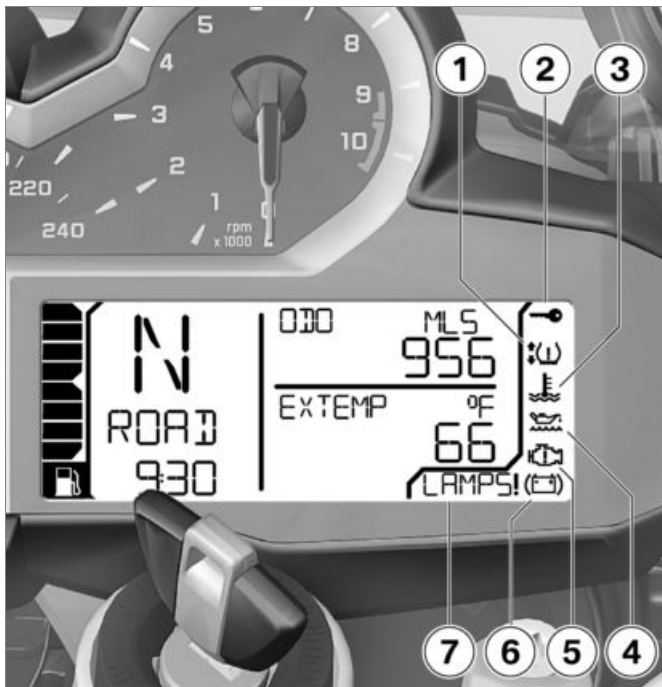

Warning symbols in the display panel

- 1 – with Tire Pressure Control (TPC/RDC)^{OE}
Tire inflation pressures (➡ 39)
- 2 Electronic immobilizer (➡ 29)
- 3 Coolant temperature (➡ 29)
- 4 Engine oil level (➡ 36)
- 5 Electronic engine management (➡ 30)
- 6 Battery charging (➡ 121)
- 7 Warnings (➡ 24)

Warning lamps

Display of the warning lamps

Warnings are displayed with the corresponding warning lamps.











Warnings for which no separate warning lamp is provided are signaled by the general warning lamp **1** and are accompanied by a warning symbol in area **2** or by a warning notice in area **3**. The universal warning lamp shows red or yellow, depending on the urgency of the warning.

The universal warning lamp lights up for the most urgent warning.









The following page contains a list of potential warnings.

Overview of warning indicators

Warning and indicator lamps	Warning symbols in the display panel	Meaning
	 appears on the display	Outside temperature warning (►►► 29)
 lights up yellow	 appears on the display	Electronic immobilizer is active (►►► 29)
 lights up red	 appears on the display	Coolant temperature too high (►►► 29)
 lights up yellow	 appears on the display	Engine in emergency-operation mode (►►► 30)
 lights up yellow	LAMP_ ! is indicated	Bulb defect (►►► 30)
	LAMPF ! is indicated	
	DWALO ! is indicated	Anti-theft alarm battery low charge (►►► 30)
 lights up yellow	DWA ! is indicated	Anti-theft alarm system battery discharged (►►► 31)

Warning and indicator lamps









Warning symbols in the display panel

		Meaning
 lights up yellow	 indicated with one or two arrows and critical tire-inflation pressure also flashes.	Tire inflation pressure is at limit of approved range (→ 31)
 flashes red	 indicated with one or two arrows and critical tire-inflation pressure also flashes.	Tire inflation pressure is outside approved range (→ 31)
 lights up yellow	 appears with one or two arrows. "—" or "— —" is indicated.	Sensor defective or system error (→ 32)
	"—" or "— —" is indicated.	Transmission error (→ 32)
 lights up yellow	RDC ! is indicated.	Battery of tire-inflation pressure sensor weak (→ 33)
 flashes		ABS self-diagnosis not completed (→ 33)

Warning and indicator lamps

Warning symbols in the display panel

Meaning

	lights up		ABS error (▬▬▬▶ 34)
	lights up		ABS deactivated (▬▬▬▶ 34)
	flashes rapidly		ASC intervention (▬▬▬▶ 34)
	flashes slowly		ASC self-diagnosis not completed (▬▬▬▶ 34)
	lights up		ASC deactivated (▬▬▬▶ 35)
	lights up		ASC error (▬▬▬▶ 35)
	lights up yellow	ESA ! is indicated	ESA error (▬▬▬▶ 35)
	lights up		Fuel down to reserve (▬▬▬▶ 35)

Warning and indicator lamps

Warning symbols in the display panel

Meaning



flashes yellow



flashes

Severe fault in the engine management system (→ 35)



appears on the display

Engine oil level too low (→ 36)

OILLVL CHECK
is indicated



lights up red



appears on the display

Battery charging voltage insufficient (→ 36)

Engine in emergency-operation mode



The general warning lamp lights up yellow.



The engine symbol is displayed.



The engine is in the emergency operating mode. Unusual engine response is a possibility.

Adapt your style of riding accordingly. Avoid accelerating sharply and overtaking. ◀

Possible cause:

The engine control unit has diagnosed a fault. In exceptional cases, the engine stops and can no longer be started. Otherwise, the engine runs in the emergency operating mode.

- Continued driving is possible, however the accustomed engine performance may not be available.

- Have the malfunction corrected as soon as possible at an authorized workshop, preferably an authorized BMW Motorrad retailer.

Bulb defect



The general warning lamp lights up yellow.

LAMP_ ! is indicated.

- LAMPR !: Brake light, rear light, turn indicator or license plate illumination defective.
- LAMPF !: Lowbeam headlamp, high-beam headlamp, parking lamps or front turn indicator defective.
- LAMPS !: Several bulbs defective.



Failure of a bulb on the motorcycle is a safety risk because it potentially makes the motorcycle less noticeable to other road users.

Replace defective bulbs as soon

as possible; it is best always to carry a complete set of spare bulbs on the motorcycle. ◀

Possible cause:

One or more bulbs are defective.

- Determine defective bulbs via visual inspection.
- Replacing bulbs for dipped and main-beam headlights (▣▣▣ 113).
- Replacing bulb for parking light (▣▣▣ 115).
- Replace the LED headlight (▣▣▣ 117).
- Replacing bulb for front and rear turn indicator (▣▣▣ 116).
- Replace LED tail light (▣▣▣ 117).

Anti-theft alarm battery low charge

– with anti-theft alarm^{OE}

DWALO ! is indicated.



This fault message is only shown for a short time im-

mediately following the Pre-Ride-Check.◀

Possible cause:

The anti-theft alarm battery no longer has its full capacity. The operation of the anti-theft alarm system is only ensured for a limited time with the vehicle battery disconnected.

- Contact an authorized workshop, preferably an authorized BMW Motorrad retailer.

Anti-theft alarm system battery discharged

– with anti-theft alarm^{OE}

 The general warning lamp lights up yellow.

DWA ! is indicated.

 This fault message is only shown for a short time immediately following the Pre-Ride-Check.◀

Possible cause:

The anti-theft alarm system battery has no capacity. The operation of the anti-theft alarm system is no longer ensured with the vehicle battery disconnected.

- Contact an authorized workshop, preferably an authorized BMW Motorrad retailer.

Tire inflation pressure is at limit of approved range

– with Tire Pressure Control (TPC/RDC)^{OE}

 The general warning lamp lights up yellow.

 The tire symbol with one or two arrows appears. The critical tire-inflation pressure also flashes.

The up arrow indicates an inflation pressure problem on the front wheel. The down arrow

indicates an inflation pressure problem on the rear wheel.

Possible cause:

The measured tire inflation pressure is in the limit area of the permissible tolerance.

- Correct tire inflation pressure in accordance with instructions on back of cover of Rider's Manual.

 Before adjusting the tire inflation pressure, observe the information on temperature compensation and on inflation pressure adjustment in the chapter "Technology in detail".◀

Tire inflation pressure is outside approved range

– with Tire Pressure Control (TPC/RDC)^{OE}

 The general warning lamp flashes red.



The tire symbol with one or two arrows appears. The critical tire-inflation pressure also flashes.



A tire inflation pressure outside the permissible tolerance result in poorer handling of the motorcycle.

Adapt your style of riding accordingly. ◀

The up arrow indicates an inflation pressure problem on the front wheel. The down arrow indicates an inflation pressure problem on the rear wheel.

Possible cause:

The measured tire inflation pressure is outside the approved tolerance range.

- Check tire for damage and suitability for continued use.

If it is still possible to drive with tire:

- Correct tire inflation pressure at the next opportunity.



Before adjusting the tire inflation pressure, observe the information on temperature compensation and on inflation pressure adjustment in the chapter "Technology in detail". ◀



The RDC warning message can be deactivated in the off-road mode. ◀

- Have the tire checked for damage at an authorized service facility, preferably an authorized BMW Motorrad retailer.

If you are unsure about the tire's suitability for continued riding:

- Do not continue riding.
- Contact roadside service.

Sensor defective or system error

– with Tire Pressure Control (TPC/RDC)^{OE}



The general warning lamp lights up yellow.



The tire symbol with one or two arrows appears.

"--" or "-- --" is indicated.

Possible cause:

Wheels without installed TPC/RDC sensors are mounted.

- Retrofit wheel set with TPC/RDC sensors.

Possible cause:

1 or 2 TCP/RDC sensors have failed or a system error has occurred.

- Have fault eliminated at a specialist service facility, preferably an authorized BMW Motorrad retailer.

Transmission error

– with Tire Pressure Control (TPC/RDC)^{OE}

"--" or "-- --" is indicated.

Possible cause:

The motorcycle has not reached the minimum speed ( 95).



TCP/RDC sensor is not active

min 19 mph (min 30 km/h)
(The RDC sensor does not send its signal to the motorcycle until after the minimum speed has been exceeded.)

- Watch the TCP/RDC display at a higher rate of speed. A continuous error is only present if the general warning lamp also lights up. In this case:
- Have fault eliminated at a specialist service facility, preferably an authorized BMW Motorrad retailer.

Possible cause:

There is a fault in the radio connection to the TPC/RDC sensors. Possible causes are radio systems in the surrounding area,

which interfere with the connection between the TPC/RDC control unit and the sensors.

- Watch the TPC/RDC display in another environment. A continuous error is only present if the general warning lamp also lights up. In this case:
- Have fault eliminated at a specialist service facility, preferably an authorized BMW Motorrad dealer.

Battery of tire-inflation pressure sensor weak

– with Tire Pressure Control (TPC/RDC)^{OE}



The general warning lamp lights up yellow.

RDC ! is indicated.



This fault message is only shown for a short time immediately following the Pre-Ride-Check. ◀

Possible cause:

The battery of the tire inflation pressure sensor no longer has its full capacity. The operation of the tire inflation pressure control is only ensured for a limited time.

- Contact an authorized workshop, preferably an authorized BMW Motorrad retailer.

ABS self-diagnosis not completed



ABS warning lamp flashes.

Possible cause:



ABS self-diagnosis not completed

The ABS function is not available, as the self-diagnosis function has not been completed. (To check the wheel sensors, the motorcycle must reach a minimum speed: min 3 mph (min 5 km/h))

- Ride off slowly. It must be noted that the ABS function is not available until the self-diagnosis has been completed.

ABS error



ABS warning lamp lights up.

Possible cause:

The ABS control unit has detected an error. The ABS function is not available.

- It remains possible to continue riding. Observe additional information on special conditions that can lead to an ABS error message (► 93).
- Have the malfunction corrected as soon as possible at an authorized workshop, preferably an authorized BMW Motorrad retailer.

ABS deactivated



ABS warning lamp lights up.

Possible cause:

The ABS system has been deactivated by the rider.

- Switch on ABS function.

ASC intervention



The ASC warning lamp flashes rapidly.

The ASC has detected instability at the rear wheel and has reduced the torque. The warning lamp flashes longer than the ASC intervention lasts. This feature continues to furnish the rider with visual feedback confirming that the system has initiated active closed-loop intervention even after the critical situation has passed.

ASC self-diagnosis not completed



The ASC warning lamp flashes slowly.

Possible cause:



ASC self-diagnosis not completed

The ASC function is not available, as the self-diagnosis function has not been completed. (To check the wheel sensors, the motorcycle must reach a minimum speed: min 3 mph (min 5 km/h))

- Ride off slowly. The ASC warning lamp must go out after a few meters.

If the ASC warning lamp continues to flash:

- Contact an authorized workshop, preferably an authorized BMW Motorrad retailer.

ASC deactivated



The ASC warning lamp lights up.

Possible cause:

The ASC system has been deactivated by the rider.

- Activating the ASC function.

ASC error



The ASC warning lamp lights up.

Possible cause:

The ASC control unit has detected an error. The ASC function is not available.

- It remains possible to continue riding. Please be aware that ASC functionality is no longer available. Observe additional information on situations which can lead to an ASC error (►► 94).
- Have the malfunction corrected as soon as possible at an authorized workshop, preferably

an authorized BMW Motorrad retailer.

ESA error



The general warning lamp lights up yellow.

ESA! is indicated.

Possible cause:

The ESA control unit has detected an error. Motorcycle damping is in this condition very firm and riding is rather uncomfortable - in particular on rough roads.

- Have the malfunction corrected as soon as possible at an authorized workshop, preferably an authorized BMW Motorrad retailer.

Fuel down to reserve



Fuel-reserve warning lamp lights up.



A fuel shortage can cause irregular engine operation or engine shut-off (accident hazard) and the catalytic converter can be damaged.

Do not drive to the extent that the fuel tank is completely empty. ◀

Possible cause:

At the most, the fuel tank still contains the reserve fuel quantity.



Reserve fuel quantity

Approx. 1.1 gal (Approx. 4 l)

- Refueling procedure (►► 85).

Severe fault in the engine management system



The general warning lamp flashes yellow.



The engine symbol flashes.

 The engine is in the emergency operating mode. A risk of damaging the engine cannot be excluded.

Adapting style of riding: Ride slowly, avoid accelerating and overtaking.

If possible, have motorcycle picked up and have fault eliminated by a specialized workshop, preferably an authorized BMW Motorrad retailer.◀

Possible cause:

The engine control unit has diagnosed a fault, which can lead to a severe secondary fault. The engine is in the emergency-operation mode.

- Continued driving is possible, however it is not recommended.
- Avoid high load and engine speed ranges if possible.
- Have the malfunction corrected as soon as possible at an au-

thorized workshop, preferably an authorized BMW Motorrad retailer.

Engine oil level too low



The oil can symbol is displayed.

OILLVL CHECK is indicated. Possible cause:

The electronic oil level sensor has detected a low engine oil level. At next refueling stop:

- Checking engine oil level (▣► 99).

If oil level is too low:

- Top up engine oil (▣► 100).

If the oil level is correct:

- Contact an authorized workshop, preferably an authorized BMW Motorrad retailer.

Battery charging voltage insufficient



The general warning lamp lights up red.



The battery symbol is displayed.



A discharged battery will lead to the failure of various motorcycle systems such as lighting, engine or ABS. This can result in dangerous driving situations.

Do not continue riding.◀

The battery is not being charged. If you continue driving, the motorcycle electronics will discharge the battery.



If the 12 V battery is installed incorrectly, or if the terminals are exchanged (e.g. when jump-starting), this can result in the fuse for the alternator regulator blowing.◀

Possible cause:

Alternator or alternator drive defective or fuse for alternator regulator has blown.

- Have the malfunction corrected as soon as possible at an authorized workshop, preferably an authorized BMW Motorrad retailer.

Outside temperature

Engine heat can lead to spurious readings of outside temperature when the motorcycle is stationary. When the effects of engine heat on the monitored temperature become excessive the display responds by temporarily reverting to -- as the display reading.



In the case of outside temperatures below 37 °F (3 °C), risk of ice formation exists. The display automatically switches from any other mode to outside temperature reading **1**, when the temperature drops below this threshold for the first time. The displayed value flashes.



In addition, the ice crystal symbol **2** is displayed.



The outside temperature warning does not mean that there is no risk of black ice form-

ing at measured temperatures above 37 °F (3 °C).

At low outside temperatures, icy conditions must especially be expected on bridges and in shady road areas. ◀

Fuel reserve

The fuel level in the fuel tank, when the fuel warning lamp switches on, depends on the driving dynamics. The more the fuel is moved within the tank (due to frequently changing inclined positions, frequent braking and accelerating), the more difficult it is to determine the reserve quantity. For this reason, the reserve quantity cannot be accurately indicated.



After the fuel warning lamp is switched on, the range is automatically displayed. The distance, which can still be driven with the reserve quantity,

depends on the driving style (on the consumption) and on the fuel level when the warning lamp was initially activated (see the explanation above).

The odometer for the fuel reserve is reset if the fuel level after refueling is greater than the reserve quantity.

Oil level indicator



The oil level indicator **1** provides information on the oil level in the engine. It can only be displayed when the vehicle is stopped.

The conditions for the oil level indicator are as follows:

- Engine at operating temperature
- Engine idling for at least ten seconds
- Side stand retracted
- Motorcycle standing vertically on a level surface.

The readings mean:

OK: Oil level correct.

CHECK: Check oil level during next refueling stop.

---: No measurement possible (above-mentioned conditions not met).



If the oil level must be checked, symbol **2** is displayed, until the oil level is detected again as correct.

Service display



If the time remaining until the next service is within one month, or if the next service is due within 621 mls (1,000 km), service date **1** and the remaining kilometers (mileage) **2** appear for a short period of time after the Pre-Ride-Check.



When a service date elapses without service, the general warning lamp lights up in yellow, appearing together with the date and mileage (kilometrage) display. The

"Service" message is displayed continuously.

▶ If the service display appears more than a month before the service date, the stored date must be adjusted in the instrument cluster. This situation can occur if the battery has been disconnected for a longer time.

Consult a certified workshop, preferably an authorized BMW Motorrad retailer, for setting of the date. ◀

Tire inflation pressures

– with Tire Pressure Control (TPC/RDC)^{OE}



The figure on the left side **1** indicates the front tire's inflation pressure, while the figure on the right **2** shows the inflation pressure in the rear tire. Immediately after switching on the ignition, "-- --" is indicated. The transfer of the inflation pressure values does not begin until a speed of 18 mph (30 km/h) is exceeded for the first time. The displayed tire inflation pressures refer to a tire air temperature of 68 °F (20 °C).

 If the **3** symbol appears at the same time, the display is a warning. The critical tire-inflation pressure flashes.

 If the critical value is at the limit of the permissible tolerance, the general warning lamp also lights up in yellow. If the monitored tire inflation pressure is outside the specified range the general warning lamp will flash in red.

Additional information on the BMW Motorrad Tire Pressure Monitor is provided starting on page (➡ 95).

Upshift recommendation

The upshift recommendation must be switched on in the display settings (➡ 46).



Upshift recommendation **1** signals the economically best point in time for upshifting.

Operation

Steering and ignition lock	42	Spring preload	64
Ignition.....	43	Damping.....	64
EWS Electronic immobilizer.....	43	Dynamic ESA, Electronic Suspension Adjustment	65
Multifunction display	44	Clutch	67
Anti-theft alarm system (DWA).....	50	Brakes	68
Emergency on/off switch (kill switch).....	52	Tires.....	68
Headlight	53	Handlebars	69
Lights.....	54	Heated handlebar grips	69
Turn indicator.....	55	Mirrors	70
Hazard warning flashers.....	55	Windshield.....	71
BMW Motorrad Integral ABS	56	Rider and passenger seats.....	71
ASC Automatic Stability Control	57		
Riding mode	58		
Cruise control.....	61		

Steering and ignition lock

Keys

You are provided with 2 ignition keys.

Should you lose your keys, refer to the information regarding the electronic immobilizer (EWS) (▶▶ 43).

A single key fits the steering and ignition lock, the fuel filler cap and the seat lock.

- with case^{OA}
- with topcase^{OA}

The cases and the topcase can also be ordered with locks for the same key on request. Please contact an authorized workshop for this purpose, preferably an authorized BMW Motorrad retailer.

Locking handlebars

 If the motorcycle is on the side stand, the surface of the ground will determine whether it is better to turn the handlebars to the left or right. However, the motorcycle is more stable on a level surface with the handlebars turned to the left than with the handlebars turned to the right.

On level ground, always turn the handlebars to the left to set the steering lock. ◀

- Turn handlebars to full left or right lock position.

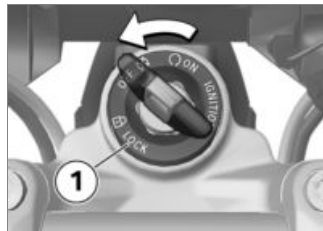

- Turn key to position **1** while moving handlebars slightly.
 - » Ignition, lights and all electrical circuits switched off.
 - » Handlebars are locked.
 - » Key can now be removed.

Ignition

Switching on ignition

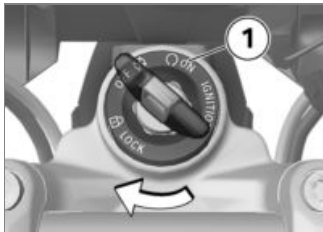

- Insert key into the steering and ignition lock. Turn key to position **1**.
 - » Parking lights and all function circuits are switched on.
 - » Pre-Ride-Check is carried out. (►► 79)
 - » ABS self-diagnosis in progress. (►► 80)
 - » ASC self-diagnosis in progress. (►► 80)

Welcome light

- Switch on ignition.
 - » The parking lamp briefly lights up.
 - with additional LED headlight^{OA}
 - » The auxiliary headlights and the rear parking lamp briefly light up.◀

Switching off ignition

- with LED headlights^{OE}

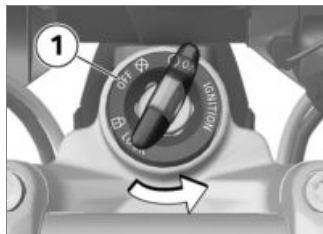

- Turn key to position **1**.
 - » The LED headlights continue to light up for a while.

- » Handlebars not locked.
- » Electrically powered accessories remain operational for a limited period of time.
- » Battery can be recharged via onboard socket.
- » After the ignition is switched off, the instrument cluster remains switched on for a short period of time and indicates possibly present fault codes.
- » Key can now be removed.

EWS Electronic immobilizer

The motorcycle's electronic circuitry monitors the data stored in the ignition key through a ring antenna incorporated in the steering and ignition lock. The engine management system does not enable engine starting until this key has been recognized as "authorized" for your motorcycle.

▶ A further key attached to the same ring as the ignition key used to start the engine could "irritate" the electronics, in which case the enabling signal for starting is not issued. The EWS warning is shown in the multifunction display.

Always store further vehicle keys separately from the ignition key. ◀

If you lose your vehicle key, you can have it disabled by your authorized BMW retailer.

When having a key disabled you should also bring all of the motorcycle's remaining keys with you. The engine can no longer be started using a disabled key; however, a disabled key can be enabled again.

Emergency and spare keys are only available through an authorized BMW Motorrad retailer.

The keys are part of an integrated security system, obligating

the retailer to check the legitimacy of all applications for replacement/extra keys.

Multifunction display

Selecting display readings

- Switch on ignition (▶▶▶ 43).



- Press button **1** briefly to select the display in the top line of display **2**.

In the case of standard equipment, the following values can be displayed and selected per push of a button:

- Total mileage (ODO)

- Trip odometer 1 (TRIP I)
- Trip odometer 2 (TRIP II)
- Range (RANGE)
- SETUP menu (SETUP), while stationary only

– with onboard computer Pro^{OE}
The following information is additionally displayed using the onboard computer Pro:

- Automatic odometer (TRIP A)
- Current fuel consumption (CONS C)
- Current speed (SPEED)◀



- Average speed (Ø SPEED)
- with Tire Pressure Control (TPC/RDC)^{OE}
- Tire inflation pressures (option) (TPM/RDC)◀
- Date (DATE)
- Oil level indicator (OILLVL)

- Press button **1** briefly to select the display in the bottom line of display **2**.

In the case of standard equipment, the following values can be displayed and selected per push of a button:

- Outside temperature (EXTEMP)
- Engine temperature (ENTEMP)
- Average consumption 1 (CONS 1)
- Average consumption 2 (CONS 2)

- with onboard computer Pro^{OE}
- Onboard electrical system voltage (VOLTGE)◀
- with onboard computer Pro^{OE}
- Stopwatch overall time (ALTIME)◀
- with onboard computer Pro^{OE}
- Stopwatch driving time (RDTIME)◀

Resetting tripmeter

- Switch on ignition (☛ 43).



- Repeat pressing button **1** briefly, until the odometer to be reset is shown in the top line of the display **2**.
- Press and hold button **1** until displayed value has been reset.

Resetting average data

- Switch on ignition (☛ 43).



- Repeat pressing button **1** briefly, until the average value to be reset is shown in the bottom line of the display **2**.
- Press and hold button **1** until displayed value has been reset.

Configuring functions

- Switch on ignition (III 43).



- Repeat pressing button **1** briefly, until in the top line of the display **2** SETUP ENTER is shown.
- Press and hold button **1** to start the SETUP menu.
- » The following is indicated in the display depending on the equipment selected.



- Press button **1** briefly to respectively switch to the next menu item.
 - » The menu item appears in the top line of the display **2**.
 - » The adjusted value appears in the bottom line of the display **3**.
 - Press button **4** briefly to change the adjusted value.
- The following menu items can be selected:
- with anti-theft alarm^{OE}
 - DWA: Switch anti-theft alarm system on (ON) respectively off (OFF)◀

- with preparation for navigation system^{OE}
 - GPS TM: If a navigation system is installed: apply GPS time and GPS date (ON) respectively do not apply them (OFF)◀
 - CLOCK: Setting the clock
 - DATE: Setting the date
 - ECOSFT: Show upshift recommendation in the display (ON) respectively do not show it (OFF)
 - BRIGHT: Adjust display brightness from normal (0) to bright (5)
 - EXIT: Exit SETUP menu
-
- with onboard computer Pro^{OE}
 - BC CUSTOM: Start display customization◀



- In order to exit the SETUP menu, press and hold menu item SETUP EXIT, button **1**.
- In order to exit the SETUP menu at any time, press and hold button **2**.

Setting clock

- Switch on ignition (▶▶▶ 43).

⚠ Attempting to set the clock while riding the motorcycle can lead to accidents.

Adjust the clock only when the motorcycle is stationary.◀

- In the SETUP menu, select the SETUP CLOCK menu item.



- Press and hold button **2**, until the hours flash in the bottom line of display **3**.

▶ If "-- : --" is indicated instead of the time, the power supply to the instrument cluster was interrupted (e.g., the battery was disconnected).◀

- Increase the flashing value using button **1** respectively decrease it using button **2**.

- Press and hold button **2**, until the minutes flash in the bottom line of display **3**.
- Increase the flashing value using button **1** respectively decrease it using button **2**.
- Press and hold button **2**, until the minutes stop flashing.
- » The adjustment is completed.
- In order to cancel the adjustment at any time, press and hold button **1**, until the original value is displayed again.

▶ The adjustment is canceled, if you ride off before the adjustment is completed.◀

Setting date

- Switch on ignition (►► 43).
- In the **SETUP** menu, select the **SETUP DATE** menu item.



- Press and hold button **2**, until the month flashes in the bottom line of display **3**.

▶ If "-- . -- . --" is indicated instead of the date, the power supply to the instrument cluster was interrupted (e.g., the battery was disconnected).◀

- Increase the flashing value using button **1** respectively decrease it using button **2**.
- Press and hold button **2**, until the day flashes in the bottom line of display **3**.

- Increase the flashing value using button **1** respectively decrease it using button **2**.
- Press and hold button **2**, until the year flashes in the bottom line of display **3**.
- Increase the flashing value using button **1** respectively decrease it using button **2**.
- Press and hold button **2**, until the year stops flashing.
- » The adjustment is completed.
- In order to cancel the adjustment at any time, press and hold button **1**, until the original value is displayed again.

▶ The adjustment is canceled, if you ride off before the adjustment is completed.◀

Customizing display

- with onboard computer Pro^{OE}
- Switch on ignition (►► 43).

In the individualization menu it is possible to adjust, which information should be shown in which display line.

- In the SETUP menu, select the SETUP BC BASIC menu item.



- Press button **1** briefly to start the individualization menu.
 - » SETUP BC CUSTOM is indicated.
- Press button **1** briefly again to exit the individualization menu.

▶ If SETUP BC BASIC is selected, the factory setting becomes active again. The CUSTOM individualization remains stored.◀



- Press and hold button **1** to display the first menu item.
 - » SETUP BC ODO is indicated.



- Press button **2** briefly to respectively switch to the next menu item.
 - » The menu item appears in the top line of the display **3**.
 - » The adjusted value appears in the bottom line of the display **4**. The following values can be adjusted.
 - TOP: The value is indicated in the top line of the display.
 - BELOW: The value is indicated in the bottom line of the display.
 - BOTH: The value is indicated in both lines of the display.

- OFF: The value is not indicated.
 - Press button **1** briefly to change the adjusted value.
- The following menu items can be selected. The factory setting is indicated in parentheses. Some menu items are displayed only, if the respective optional equipment is installed.
- ODO: Odometer (TOP, setting OFF is not possible)
 - TRIP 1: Tripmeter 1 (TOP)
 - TRIP 2: Tripmeter 2 (TOP)
 - TRIP A: Automatic tripmeter (TOP)
 - EXTEMP: Ambient temperature (BELOW)
 - ENGTMP: Engine temperature (BELOW)
 - RANGE: Range (TOP)
 - CONS R: Average consumption for range calculation (OFF)
 - CONS 1: Average consumption 1 (BELOW)

- CONS 2: Average consumption 2 (BELOW)
- CONS C: Current fuel consumption (TOP)
- ØSPEED: Average speed (BELOW)
- SPEED: Current speed (TOP)
- RDC: Tire inflation pressures (BELOW)
- VOLTGE: Onboard electrical system voltage (BELOW)
- ALTIME: Stopwatch overall time (BELOW)
- RDTIME: Stopwatch driving time (BELOW)
- DATE: Date (BELOW)
- SERV T: Date of next service (OFF)
- SERV D: Remaining mileage until next service (OFF)
- OILLVL: Oil level indicator (BELOW)
- EXIT: Exit individualization menu



- In order to exit the individualization menu, press and hold menu item SETUP EXIT, button **1**.
 - In order to exit the individualization menu at any point in time, press and hold button **2**.
- » All adjustments applied until then will be stored.

Anti-theft alarm system (DWA)

- with anti-theft alarm^{OE}

Activation

- Switch on ignition (➡ 43).
- Customize anti-theft alarm system settings (➡ 52).
- Switch off ignition.
 - » If DWA is activated, DWA is automatically activated after the ignition is switched off.
 - » Activation takes approximately 30 seconds to complete.
 - » Turn indicators are illuminated twice.
 - » Confirmation tone sounds twice (if programmed).
 - » Anti-theft alarm system is activated.

Alarm

The alarm can be set off by:

- motion sensor
- an attempt to use an unauthorized key to switch on the ignition
- disconnecting the alarm system from the motorcycle battery (alarm system battery takes

over the power supply - alarm sound only, no illumination of the turn indicators).

All functions are sustained even if the internal battery of the anti-theft alarm system is flat; the only difference is that an alarm cannot be triggered if the system is disconnected from the motorcycle's battery.

An alarm lasts for approximately 26 seconds. During the alarm, an alarm tone sounds and the turn indicators flash. The alarm tone type can be adjusted by an authorized BMW Motorrad retailer.

If an alarm was triggered while the motorcycle was unattended, the rider is notified accordingly by an alarm tone sounding once when the ignition is switched on. The anti-theft alarm system indi-

cator lamp then signals the reason for the alarm for one minute. The meanings of the flash codes are as follows:

- Flashes 1x: Motion sensor 1
- Flashes 2x: Motion sensor 2
- Flashes 3x: Ignition switched on with unauthorized key
- Flashes 4x: Alarm system is disconnected from the motorcycle battery
- Flashes 5x: Motion sensor 3

Deactivation

- Emergency on/off switch (kill switch) in normal operating position.
- Switch on ignition.
 - » Turn indicators light up once.
 - » Confirmation tone sounds once (if programmed).
 - » Anti-theft alarm system is deactivated.

Customize anti-theft alarm system settings

- Switch on ignition (▶▶▶ 43).



- Repeat pressing button **1** briefly, until in the top line of the display **2** SETUP ENTER is shown.
- Press and hold button **1** to start the SETUP menu.



- Press button **1** briefly to respectively select the DWA menu item.
 - » The top line of the display **2** shows DWA.
 - » The adjusted value appears in the bottom line of the display **3**.
- Press button **4** briefly to change the adjusted value.
 - On: Anti-theft alarm system is activated respectively is activated automatically when the ignition is switched off.

– Off: DWA is deactivated.

Emergency on/off switch (kill switch)



- 1** Emergency on/off switch (kill switch)

⚠ Operating the emergency ON/OFF switch when riding can cause the rear wheel to lock and thus cause a fall. Do not operate the emergency ON/OFF switch when riding. ◀

The engine can be switched off easily and quickly using the emergency on/off switch.

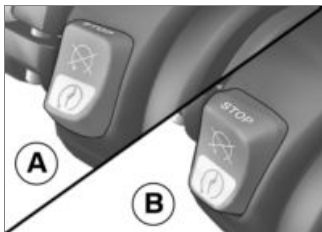

- A** Engine switched off
B Operating position

Headlight

Adjusting headlight for RHD/LHD traffic

If the motorcycle is ridden in a country where vehicles are driven in the opposite lane relative to your own country, its asymmetric low-beam headlight will tend to blind oncoming traffic.

Have the headlight adjusted for these conditions by an authorized service facility, preferably an authorized BMW retailer.

Headlamp range and spring preload

The headlamp range generally remains constant due to the adjustment of the spring preload to the loading state.

Spring preload adjustment may only be insufficient when the motorcycle is very heavily loaded. In this case, the headlamp range must be adjusted to the weight.

▶ If there are questions whether the headlight range is correct, consult a specialized workshop, preferably an authorized BMW Motorrad retailer. ◀

Headlight range adjustment



In the case of high payload, if the spring preload adjustment is not sufficient anymore to avoid blinding the oncoming traffic:

- Turn adjustment wheel **1** counterclockwise to lower the headlight beam.

If the motorcycle is ridden again with lower payload:

- Have the headlight default setting readjusted by an authorized workshop, preferably an authorized BMW Motorrad retailer.

– with LED headlights^{OE}



- A swiveling lever is used for the headlight range adjustment.
- **A** Neutral position
- **B** Position with heavy payload<

Lights

Lowbeam headlamp and parking lamps

The parking lamps come on automatically when the ignition is switched on.

▷ The parking lights are a strain on the battery. Do not leave the ignition switched

on longer than absolutely necessary.◀

The lowbeam headlamp switches on automatically when the engine is switched on.

High-beam headlight and headlight flasher

- Switch on ignition (▶▶▶ 43).

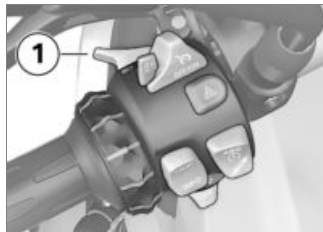

- Press switch **1** toward front to switch on high beams.
- Pull switch **1** rearward to actuate headlight flasher.

Parking light

– with LED headlights^{OE}

- Switch off ignition (▶▶▶ 43).



- Immediately after switching off the ignition press the **1** button and maintain pressure until the parking light come on.
- Switch ignition on and then off again to switch off parking light.

Auxiliary headlight

– with additional LED headlight^{OA}

Precondition: The auxiliary headlight is only active, if the low-beam headlight is active.

- Start engine (▶▶▶ 78).



- Press button **1** to switch on the auxiliary headlights.

 The indicator lamp for the auxiliary headlight lights up.

- Press button **1** again to switch off the auxiliary headlights.

Turn indicator

Operating turn indicator

- Switch on ignition (▶▶▶ 43).

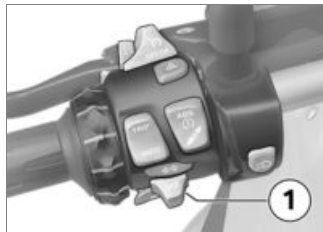

- Press button **1** toward left to switch on left-hand turn indicator.
- Press button **1** toward right to switch on right-hand turn indicator.
- Press button **1** into center position to switch off turn indicators.



Turn indicator cancellation

The turn indicators automatically switch off after the defined time and distance.

min 10 s

min 984.3 ft (min 300 m)

Hazard warning flashers

Operating hazard warning flashers

- Switch on ignition.

 The hazard warning flashers place a strain on the battery. Do not use the hazard warning flashers for longer than absolutely necessary.◀

 If a turn indicator button is pressed with the ignition switched on, the flashing function replaces the emergency flashing function as long as the button is

pressed. If the turn indicator button is released, the emergency flasher function becomes active again.◀



- Press button **1** to switch on hazard warning flashers.
- » Ignition can be switched off.
- Press button **1** again to switch off hazard warning flashers.

BMW Motorrad Integral ABS

Switch off ABS function

- Switch on ignition (▶▶▶ 43).

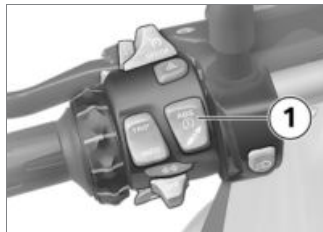

- Press and hold button **1** until ABS warning lamp's display changes.
- » First the ASC symbol changes its display behavior. Press and hold button **1** until ABS warning lamp reacts. In this case, the ASC setting does not change.



ABS warning lamp lights up.

- Release button **1** within two seconds.



ABS warning lamp remains on.

» ABS function is deactivated, integral function continues to be active.

Behavior with ABS deactivated

With the ABS function switched off, first only the control on the front wheel is deactivated. If the motorcycle is then only braked with the handbrake lever, ABS control continues to be active for the rear wheel also braked via the integral function. The ABS control for the rear wheel is not switched off until the footbrake lever is actuated.

Switch on ABS function

- Switch on ignition (☛ 43).

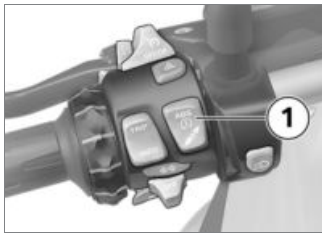

- Press and hold button **1** until ABS warning lamp's display changes.

 ABS warning lamp goes out; if self-diagnosis has not been completed, it begins to flash.

- Release button **1** within two seconds.

 ABS warning lamp remains off or continues to flash.

» ABS function is switched on.

- As an alternative, the ignition can also be switched off and then on again.

 If the ABS warning lamp lights up after switching the ignition off and on and then continued driving over 3 mph (5 km/h), an ABS error has occurred.◀

ASC Automatic Stability Control

Deactivate ASC function

 The ASC function can also be deactivated while driving.◀

- Switch on ignition (☛ 43).

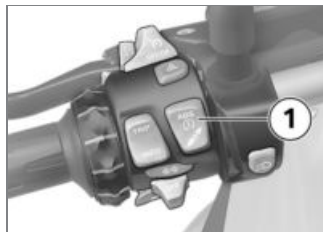

- Press the **1** button and continue to hold it down until the status indicated by the ASC warning lamp changes.

 The ASC warning lamp lights up.

- Release button **1** within two seconds.

 The ASC warning lamp continues to light up.

» ASC function is deactivated.

Activate ASC function

- Switch on ignition (☛ 43).

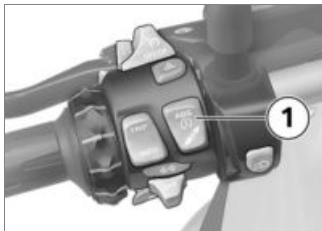

- Press the **1** button and continue to hold it down until the status indicated by the ASC warning lamp changes.

 The ASC warning lamp does not light up anymore; if self-diagnosis has not been completed, it begins to flash.

- Release button **1** within two seconds.

 The ASC warning lamp still does not light up respectively continues flashing.

» ASC function is activated.

- As an alternative, the ignition can also be switched off and then on again.

 If the ASC warning lamp lights up after switching the ignition off and on and then continued driving over 3 mph (5 km/h), an ASC error has occurred.◀

Riding mode

Use of the riding modes

BMW Motorrad has developed 5 riding scenarios for your motorcycle from which you can select the one matching your situation:

- Riding on wet roads
- Riding on dry roads
- with Pro driving modes^{OE}
- Brisk riding on dry roads
- Moderate off-road riding
- Challenging off-road riding

For each of those 5 scenarios, the optimum balance between engine torque, throttle response, ABS control and ASC control for the situation concerned is provided.

– with dynamic ESA^{OE}

The suspension settings is adjusted to the selected scenario as well.

Setting riding mode

- Switch on ignition (➡ 43).



- Press button **1**.

Details on the selectable driving modes are provided in the chapter "Technology in Detail". ◀



The selection arrow **1** and the first selectable riding mode **2** are displayed.



! Off-road mode (Enduro and Enduro Pro) is not intended for normal road operation. Switching the off-road mode (Enduro and Enduro Pro) on during road operation can result in unstable riding conditions when braking in ABS or accelerating in ASC. This results in a danger of falling.

Switch off-road mode (Enduro and Enduro Pro) during off-road riding on only. ◀

- Press button **1** repeatedly, until the selection arrow is

shown next to the desired riding mode.

◀ When selecting the Enduro PRO mode, remember the restrictions on ABS control intervention at the rear wheel (see the chapter "Technology in detail"). ◀

The following riding modes can be selected:

- RAIN: When riding on wet roads.
- ROAD: When riding on dry roads.
- DYNA: When riding dynamically on dry roads.
- Enduro: When driving off-road.
- Enduro PRO: When riding sporty offroad (with coding plug installed only).
- with Pro driving modes^{OE}
 - » The following driving modes can also be selected:

- DYNA: When riding dynamically on dry roads.
- Enduro: When driving off-road.
- Enduro PRO: When riding sporty off-road (with coding plug installed only).
 - » When the vehicle is stationary, the selected riding mode is activated after approx. 2 seconds.
 - » The new riding mode is activated during operation under the following conditions:
 - Throttle grip in neutral position
 - Clutch disengaged
 - » After the new riding mode is activated, the clock is displayed again.
 - » The configured riding mode with the corresponding adaptations of the engine characteristics, ABS, ASC and dynamic ESA is maintained, even after the ignition is switched off.

Switching off TCP/RDC in off-road mode

- with Pro driving modes^{OE}

If you want to ride off-road with a reduced tire inflation pressure, it is possible to deactivate the TCP/RDC warning for the Enduro and Enduro Pro driving modes.

Condition: TCP/RDC is switched on.

- Switch on ignition (→ 43).



- Repeat pressing button **1** briefly, until in the top line of the display **2** SETUP ENTER is shown.

- Press and hold button **1** to start the SETUP menu.



- Press button **1** briefly to respectively select the RDC menu item.
 - » The top line of the display **2** shows RDC.
 - » The adjusted value appears in the bottom line of the display **3**.
- Press button **4** briefly to change the adjusted value.
 - » The following settings are available:
 - ON: The TCP/RDC display warning symbol is shown in the

Enduro and Enduro Pro driving modes.

- OFF: The TCP/RDC display warning symbol is not shown in the Enduro and Enduro Pro driving modes.

Install coding plug

- with Pro driving modes^{OE}
- with LED headlights^{OE}
- Switch off ignition (▶▶▶ 43).
- Remove rider's seat (▶▶▶ 72).



 Dirt and moisture can get into the open plug and cause malfunctions.

After removing the encoding plug, refit the cover cap. ◀

- Remove cover cap of the plug connection **1**.

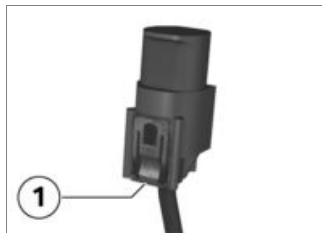

- To do so, press in locking device **1** and pull off cap.
- Insert the coding plug.
- Switch on ignition.



Symbol **1** for the coding plug appears on the display. Riding mode **2** Enduro PRO can be selected.

- » The selected riding mode remains active even after the ignition is switched off.
- Install rider's seat (▶▶▶ 72).

Cruise control

– with cruise control^{OE}

Switching on cruise control

The cruise-control system is not available again until after the

Enduro or Enduro Pro driving mode has been deactivated.

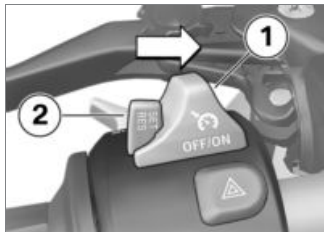

- Push switch **1** to right.
- » Button **2** is operational.

Setting road speed

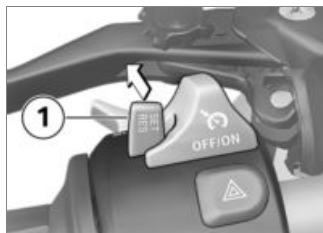

- Briefly press button **1** forward.

 Adjustment range for cruise control

19...130 mph (30...210 km/h)



Indicator lamp for cruise-control system lights up.

- » The motorcycle maintains your current cruising speed and the setting is saved.

Acceleration

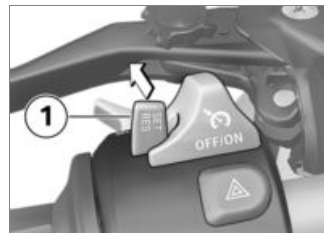

- Briefly press button **1** forward.
- » Speed is increased by 1.2 mph (2 km/h) each time button is pressed.
- Press button **1** forward and hold.
- » The motorcycle accelerates steplessly.
- » If the button **1** is no longer pressed, the speed achieved is maintained and saved.

Decreasing speed

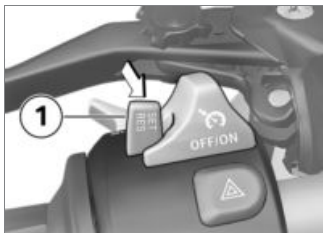

- Briefly press button **1** backward.
 - » Speed is decreased by 1.2 mph (2 km/h) each time button is pressed.
- Press button **1** back and hold.
 - » The motorcycle decelerates steplessly.
 - » If the button **1** is no longer pressed, the speed achieved is maintained and saved.

Deactivate cruise control

- Actuate brakes, clutch or throttle grip (take back throttle be-

yond back position) to deactivate cruise-control system.

- » Cruise control indicator lamp goes out.

Resuming former cruising speed

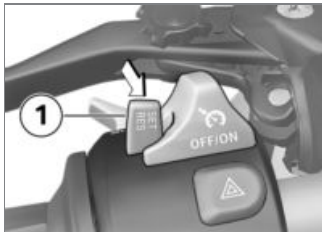

- Briefly push button **1** back to return to the speed saved beforehand.

 Opening the throttle does not deactivate the cruise-control system. If you release the throttle grip, the motorcycle will decelerate only to the cruising speed saved in memory, even

though you might have intended slowing to a lower speed. ◀



Indicator lamp for cruise-control system lights up.

Switching off cruise control

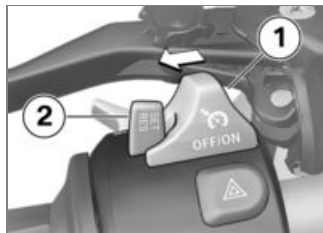

- Push switch **1** to left.
 - » The system is deactivated.
 - » Button **2** is locked.

Spring preload Setting

It is essential to set the spring preload to suit the load carried by the motorcycle. Increase spring preload when the vehicle is heavily loaded and reduce spring preload accordingly when the vehicle is lightly loaded.

Adjusting spring preload at rear wheel

 Adjusting the spring preload while the motorcycle is being ridden can lead to accidents. Adjust the spring preload only when the motorcycle is stationary. ◀

- Always check that the ground under the stand is level and firm.



 Your motorcycle's handling will suffer if you do not match the spring-preload and damping-characteristic settings. Adjust damping characteristic to changed spring preload. ◀

- To decrease spring preload, adjustment wheel **1** in direction of arrow LOW.
- To increase spring preload, turn adjustment wheel **1** in direction of arrow HIGH.



Basic setting of spring preload, rear

– without dynamic ESA^{OE}



Basic setting of spring preload, rear

Turn adjustment wheel as far as possible into LOW direction (One-up without load)

Turn adjuster wheel as far as possible in LOW direction, then rotate 15 turns in HIGH direction (One-up with load)

Turn adjuster wheel as far as possible in LOW direction, then rotate 30 turns in HIGH direction (Two-up and load) ◀

Damping Setting

The damping must be adjusted to the road conditions and the spring preload.

- A rough road surface requires softer damping than a smooth road surface.
- An increase in spring preload requires firmer damping, a re-

duction in spring preload requires softer damping.

Adjusting damping on rear wheel

- Make sure ground is level and firm and park motorcycle.
- Adjust damping from the left side of the vehicle.



- Turn adjusting screw **1** clockwise to increase damping.
- Turn adjusting screw **1** counterclockwise to decrease damping.

	Basic setting of rear wheel rear-wheel damping
– without dynamic ESA ^{OE}	
Turn adjuster wheel as far as possible clockwise, then 8 clicks counterclockwise (One-up without load)	
Turn adjuster wheel as far as possible clockwise, then 2 clicks counterclockwise (One-up with load)	
Turn adjuster wheel as far as possible clockwise, then 2 clicks counterclockwise (Two-up with load)<	

Dynamic ESA, Electronic Suspension Adjustment

– with dynamic ESA^{OE}

Adjustment options

Using the electronic suspension adjustment Dynamic ESA you can conveniently adjust your motorcycle to the load.

Using leveling sensors, Dynamic ESA detects movements of the running gear and responds to them by adjusting the damper valves. As a result, the running gear is adjusted to the conditions of the ground.

Based on the NORMAL default setting, damping can be additionally adjusted harder (HARD) or softer (SOFT).

– with Pro driving modes^{OE}

The running gear adjustment as well as the number of selectable damping variants depend on the selected riding mode. Damping set by the riding mode can be changed by the rider.

If the coding plug is not installed, the default set by the riding mode is set after every mode change. If the coding plug is installed, the rider's adjustments for every mode are maintained.

Displaying suspension setting

- Switch on ignition (☛ 43).



- Press button **1** briefly to display current adjustment.



Damping is displayed in the multifunction display in area **1**, and spring preload is indicated in area **2**.

» The display is automatically hidden again after a short time.

Adjusting chassis

- Switch on ignition (☛ 43).

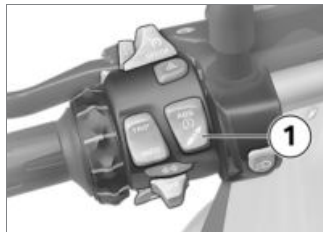

- Press button **1** briefly to display current adjustment.

To set the damping rate:

- Repeat pressing button **1** briefly until desired setting is displayed.

▶ The damping cannot be adjusted while the motorcycle is being ridden.◀

The following settings are available:

- SOFT: Comfortable damping
- NORMAL: Normal damping
- HARD: Sporty, performance-oriented damping

– with Pro driving modes^{OE}

In the ENDURO and ENDURO PRO modes two adjustments are possible only:

- SOFT: Comfortable damping
- HARD: Sporty, performance-oriented damping

To set the spring preload:

- Start the engine:

 The spring preload cannot be adjusted while the motorcycle is being ridden. ◀

- Press and hold button **1** repeatedly until desired setting is displayed.

The following settings are available:

 One-up

 One-up with luggage

 Two-up (with luggage)

- Wait for the adjustment routine to finish before starting off again.
 - » If the button **1** is not pressed for an extended period, the damping rate and the spring preload will be adjusted to the displayed settings. The ESA display flashes during the adjustment routine.
- At very low temperatures, unload the motorcycles before increasing the spring preload, and have the passenger dismount if necessary.
 - » The ESA display disappears once the adjustment procedure has been completed.

Clutch

Adjusting clutch lever

 Adjusting the clutch lever while driving can lead to accidents.

Only adjust the clutch lever when the motorcycle is stationary. ◀

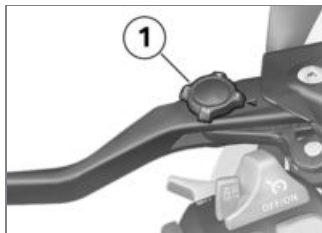

- Turn adjusting wheel **1** into desired position.

 The adjustment wheel can be turned more easily if you press the clutch lever forward when doing so. ◀

- » Four settings are available:

- Position 1: smallest distance between handlebar grip and clutch lever
- Position 4: largest distance between handlebar grip and clutch lever

Brakes

Adjusting handbrake lever

! Adjusting the handbrake lever while driving can lead to accidents. Only adjust the handbrake lever when the motorcycle is stationary.◀

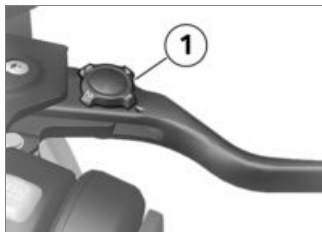

- Turn adjusting wheel **1** into desired position.

▶ The adjustment wheel can be turned more easily if you press the handbrake lever forward when doing so.◀

- » Four settings are available:
- Position 1: smallest distance between handlebar grip and brake lever
 - Position 4: largest distance between handlebar grip and brake lever

Tires

Checking tire pressure

! Incorrect tire inflation pressure results in poorer handling characteristics of the motorcycle and reduces the life of the tires.

Ensure proper tire inflation pressure.◀

! At high road speeds, tire valves installed perpendicular to the wheel rim have a tendency to open as a result of centrifugal force.

Use valve caps with rubber seals and screw them on firmly to prevent sudden tire deflation.◀

- Make sure ground is level and firm and park motorcycle.
- Check tire pressures against data below.



Tire pressure, front

36.3 psi (2.5 bar) (With tire cold)



Tire pressure, rear

42.1 psi (2.9 bar) (With tire cold)

If tire pressure is too low:

- Correct tire pressure.

Handlebars

Adjustable handlebars

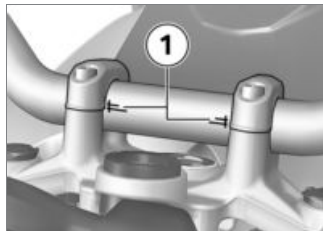

The inclination of the motorcycle handlebars can be adjusted within the **1** markings. Consult an authorized workshop, preferably an authorized BMW Motorrad retailer, for adjustment of the handlebars.

Heated handlebar grips

– with heated handlebar grips^{OE}

Operating heated grips

▶ The heated grips option can only be activated when the engine is running.◀

▶ The increase in power consumption caused by the heated grips can drain the battery if you are riding at low engine speeds. If the battery is inadequately charged, the heated grips are switched off to ensure starting capability.◀

- Start engine (▶▶▶ 78).

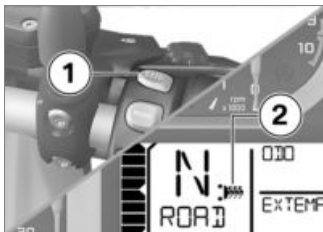

- Press button **1** repeatedly until desired heating level **2** is shown.

The handlebar grips can be heated at two different levels. The adjusted level is shown in the multifunction display, at position **1**.



50 % heating output



100 % heating output

- » The 2nd heating level is used for fast heat-up of the grips;

then the switch should be switched back to the 1st level.

- » If no further changes are made the selected heating level is adopted as the setting.
- To switch off heated grips, press button **1** until heated grip symbol **2** is no longer shown in the display.

Mirrors

Adjusting mirrors



- Move mirror into desired position by twisting.

Adjusting mirror arm

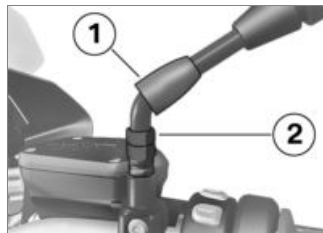

- Slide protective cap **1** up over screw connection on mirror arm.
- Loosen the nut **2**.
- Turn mirror arm into desired position.
- Tighten the nut to the specified torque while holding the mirror arm to ensure that it does not move out of position.



Mirror (locknut) on adapter

16 lb/ft (22 Nm)

- Slide protective cap **1** over screw fitting.

Windshield

Adjusting windshield

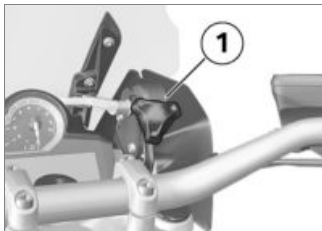

 Windshield adjustments while riding represent an accident hazard. Adjust windshield while stopped only. ◀

- Turn adjustment wheel **1** clockwise to lower the windshield.
- Turn adjustment wheel **1** counterclockwise to raise the windshield.

Rider and passenger seats

Remove passenger seat

- Make sure ground is level and firm and park motorcycle.

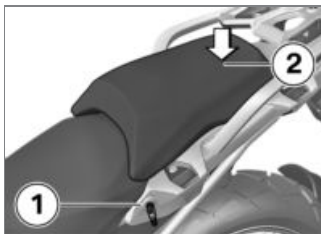

- Turn seat lock **1** to the right with ignition key and hold while pressing passenger seat downward in rear area **2** to support unlocking.
- Lift passenger seat at front and release key.
- Take off passenger seat and place on a clean surface with

upholstered side facing downward.

Installing passenger seat

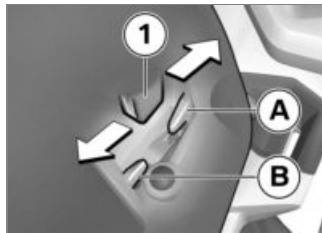

- Passenger seat can be adjusted to 2 different seat positions.
- Take adjustment direction of passenger seat into account depending on position of driver's seat:
- Insert passenger seat in mount with both lugs **1** centered.
 - High seat position: press passenger seat toward rear **A**.
 - Low seat position: press passenger set toward front **B**.

» Lugs **1** of passenger seat are correctly fixed in place.



- Firmly press down passenger seat **1** at front.
- » Passenger seat clicks audibly into place.

Removing rider's seat

- Remove passenger seat (▣▣▣▶ 71).

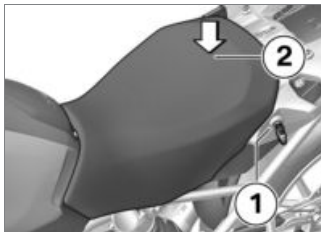

- Turn seat lock **1** to the left with ignition key and hold while pressing rider's seat downward in rear area **2** to support unlocking.
- Raise rider's seat at rear and release key.
- Take off rider's seat and place on a clean surface with upholstered side facing downward.

Installing rider's seat

- Remove passenger seat (▣▣▣▶ 71).
- Adjust seat height and seat tilt (▣▣▣▶ 72).

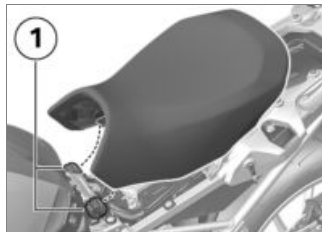

- Fit rider's seat in mounts **1** on left and right and loosely place on motorcycle.
- Press rider's seat slightly forward in rear area and then firmly downward until locking mechanism engages.

Adjust seat height and seat tilt

- Remove rider's seat (▣▣▣▶ 72).

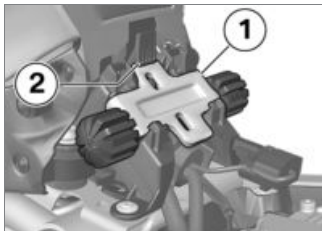

- In order to remove the front height adjustment **1**, press locking mechanism **2** down to remove the height adjustment upwards.

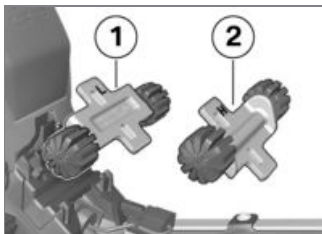

- In order to adjust the low seat position, install the front height

adjustment in orientation **1** (L marking).

- In order to adjust the high seat position, install the front height adjustment in orientation **2** (H marking).



- First, slide the front height adjustment under mounts **1**. Then press locking mechanism **2**, until it engages.

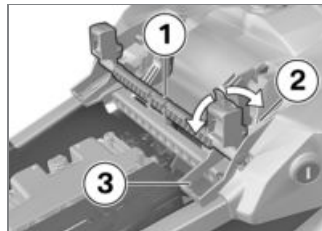

- In order to adjust the low seat position, swivel rear height adjustment **1** into position **3** (L marking).
- In order to adjust the high seat position, swivel rear height adjustment **1** into position **2** (H marking).

If seat tilt should be changed:

- Position the front and rear height adjustment differently.

Riding

Safety instructions	76
Checklist.....	78
Starting	78
Breaking in.....	81
Brakes	82
Parking your motorcycle	83
Off-road riding	83
Refueling	84
Securing motorcycle for transport	86

Safety instructions

Rider's equipment

Do not ride without the correct clothing. Always wear:

- Helmet
- Rider's suit
- Gloves
- Boots

This applies even to short journeys, and to every season of the year. Your authorized BMW Motorrad retailer will be happy to advise you and has the correct clothing for every purpose.

Reduced clearance in inclined position

- with lowering^{OE}

Motorcycles with lowered running gear have less ground clearance in all positions than motorcycles with standard running gear.



Danger of accident due to the motorcycle contacting the ground unexpectedly early. Observe the reduced ground clearance of lowered motorcycles in all positions.◀

Test the clearance of your motorcycle at an angle in safe situations. Remember to take the limited ground clearance of your motorcycle into account when driving over curbs and similar obstacles.

The lowering of the motorcycle shortens the spring travel (see the chapter "Technical Data"). A possible reduction in the accustomed driving comfort may result. Especially when riding with a passenger, the spring preload should be adjusted accordingly.

Loading



Overloading and imbalanced loads can adversely affect the motorcycle's handling. Do not exceed the gross weight limit and observe the loading information.◀

- Adjust spring preload and damping rate for the current gross vehicle weight.
 - with case^{OA}
- Ensure that case volumes on left and right are equal.
- Make sure that weight is uniformly distributed between right and left.
- Pack heavy luggage and cargo as low and as close to the center of the motorcycle as possible.
- Observe maximum payload and top speed as indicated on label in case.◀

- with topcase^{OA}
- Observe maximum payload and top speed as indicated on label in topcase.<
- with tank rucksack^{OA}
- Observe maximum payload of tank rucksack and corresponding top speed.

 Payload of tank rucksack
max 11 lbs (max 5 kg)<

Speed

If you ride at high speed, always bear in mind that various boundary conditions can adversely affect the handling of your motorcycle:

- Settings of spring-strut and shock absorber system
- Unevenly distributed load
- Loose clothing

- Insufficient tire inflation pressure
- Tire tread in poor condition
- Etc.

Maximum speed with massive-bar tires

 The maximum speed specified for the motorcycle may be higher than the maximum speed permissible for the tires. Excessively high speeds can lead to tire damage and accidents. Observe the maximum permissible speed for the tires.<

With massive-bar tires, the top speed permissible for the tire must be observed. Attach maximum permissible speed decal in field of view.

Risk of poisoning

Exhaust fumes contain carbon monoxide, which is colorless and odorless but highly toxic.

 Inhaling exhaust fumes therefore represents a health hazard and can even cause loss of consciousness with fatal consequences. Do not inhale exhaust fumes. Do not run the engine in closed rooms.<

Burn hazard

 Engine and exhaust system become very hot when the vehicle is in use. There is a risk of burn injuries by contact with hot surfaces. After parking the motorcycle, make sure that nobody comes into contact with the engine and exhaust system.<

Catalytic converter

If misfiring causes unburned fuel to enter the catalytic converter, there is a danger of overheating and damage.

For this reason, observe the following points:

- Do not run the fuel tank dry
- Do not run the engine with the spark-plug cap removed
- Stop the engine immediately if it misfires
- Use unleaded fuel only
- Comply with all specified maintenance intervals.



Unburned fuel will destroy the catalytic converter.

Note the points listed for protection of the catalytic converter.◀

Danger of overheating



Cooling would be inadequate if the engine were allowed to idle for a lengthy period with the motorcycle at a stand-

still: overheating would result. In extreme cases, the motorcycle could catch fire.

Do not allow the engine to idle unnecessarily. After starting, ride off immediately.◀

Modifications



Modifications of the motorcycle (e.g. engine management system, throttle valves, clutch) can cause damage to the affected components and failure of safety-related functions. Damage caused in this way is not covered by the warranty. Do not make any modifications.◀

Checklist

Use the following checklist to check important functions, settings and wear limits before you ride off:

Before every journey

- Brakes
- Front and rear brake fluid levels
- Coolant level
- Clutch function
- Damping setting and spring preload
- Tread depth and tire inflation pressure
- Firm seating of cases and luggage

At regular intervals

- Engine oil level (every time you refuel)
- Brake pad wear (during every third stop for refueling)

Starting

Starting engine

- Switch on ignition.
- » Pre-Ride-Check is carried out. (▶▶ 79)
- » ABS self-diagnosis in progress. (▶▶ 80)

- » ASC self-diagnosis in progress. (▮▮▮ 80)
- Engage neutral, or pull back clutch lever if a gear is engaged.

▶ You cannot start the motorcycle with the side stand extended and a gear engaged. The engine will switch itself off if it is started with the transmission in neutral and then a gear is engaged before retracting the side stand. ◀

- In the case of cold start or under cold temperatures: Pull back clutch lever.



- Press starter button **1**.

▶ The starting attempt is automatically interrupted if battery voltage is too low. Recharge the battery before you attempt to start the engine again, or use jumper cables and a donor battery to start. More detailed information can be found in the "Maintenance" chapter under "Jump-starting." ◀

- » Engine starts.
- » If the engine fails to start, the troubleshooting table in the chapter "Technical Data" may provide assistance. (▮▮▮ 144)

Pre-Ride Check

After the ignition is switched on, the instrument cluster conducts a test of the pointer instruments and the warning and indicator lamps, i.e. the so-called "Pre-Ride-Check". This test routine stops if the engine is started before it is completed.

Phase 1

The pointer of the tachometer and speedometer move to the end stop. At the same time, all warning and indicator lamps are switched on consecutively.

Phase 2

The universal warning lamp changes from yellow to red.

Phase 3

The pointer of the tachometer and speedometer move to their starting position. At the same time all of the activated warning

and indicator lamps are switched off in reverse sequence.

If a pointer has not been moved, or if one of the warning and indicator lamps has not been switched on:

- Have the malfunction corrected as soon as possible at an authorized workshop, preferably an authorized BMW Motorrad retailer.

ABS self-diagnosis

The self-diagnosis routine is determining whether the BMW Motorrad Integral ABS is ready for operation. The self-diagnosis routine launches automatically when you switch on the ignition.

Phase 1

- » Check on system components monitored by diagnostic system while vehicle is parked.



ABS warning lamp flashes.

Phase 2

- » Checking wheel sensors while starting off. The motorcycle must reach a speed of at least 3 mph (5 km/h) before the ABS self-diagnosis routine can be completed.



ABS warning lamp flashes.

ABS self-diagnosis completed

- » The ABS warning lamp goes out.

If an ABS error is indicated following completion of the ABS self-diagnosis routine:

- It remains possible to continue riding. Please be aware that neither the ABS nor the integral function is available.

- Have the malfunction corrected as soon as possible at an authorized workshop, preferably an authorized BMW Motorrad retailer.

ASC self-diagnosis

The self-diagnosis routine is determining whether the BMW Motorrad Integral ASC is ready for operation. The self-diagnosis routine launches automatically when you switch on the ignition.

Phase 1

- » Check on system components monitored by diagnostic system while vehicle is parked.



The ASC warning lamp flashes slowly.

Phase 2

- » Checking the diagnosable system components while driving. So that the ASC self-diag-

nosis can be completed, the motorcycle must be driven at a speed of at least 3 mph (5 km/h) with the engine running.



The ASC warning lamp flashes slowly.

ASC self-diagnosis completed

» The ASC symbol is no longer displayed.

If an ASC error is indicated following completion of the ASC self-diagnosis routine:

- It remains possible to continue riding. Please be aware that ASC functionality is no longer available.
- Have the malfunction corrected as soon as possible at an authorized workshop, preferably an authorized BMW Motorrad retailer.

Breaking in Engine

- While running in the motorcycle, vary the throttle opening and engine-speed range frequently; avoid driving for long periods at a constant speed.
- Choose curvy, slightly hilly sections of road if possible.
- Observe the engine run-in speeds.

 Engine break-in speeds
<5000 min ⁻¹

- Observe mileage, after which the running-in check should be performed.

 Mileage until running-in check
311...746 miles (500...1200 km)

Brake pads

New brake pads must be run in before they achieve their optimum friction force. This initial reduction in braking efficiency can be compensated for by exerting greater pressure on the brake levers.



New brake pads can extend stopping distance by a significant margin. Brake early. ◀

Tires

New tires have a smooth surface. This must be roughened by riding in a restrained manner at various heel angles until the tires are run in. This running in procedure is essential if the tires are to achieve maximum grip.



New tires do not provide full tire traction. Accident hazards exist in particular on wet roads and at extreme angles.

Always think well ahead and avoid extreme angles.◀

Brakes

How do you achieve the shortest stopping distances?

The dynamic load distribution between the front and rear wheel changes during braking. The heavier you brake, the greater the weight transfer to the front wheel. Increases in the load at an individual wheel are accompanied by a rise in the effective braking force that the wheel can provide.

To achieve the shortest possible braking distance, the front brake must be applied quickly and with increasing force. This procedure provides ideal exploitation of the extra weight transfer to the front wheel. The clutch should also be disengaged at the same time.

With the "forced braking" often practiced in which the brake pressure is generated as quickly as possible and with great force, the dynamic load distribution cannot follow the increased deceleration and the braking force cannot be completely transferred to the road surface.

Locking up of the front wheel is prevented by the BMW Motorrad Integral ABS.

Descending mountain passes



There is a danger of the brakes fading if you use only the rear brakes when descending mountain passes. Under extreme conditions, the brakes could overheat and suffer severe damage.

Use both front and rear brakes, and make use of the engine's braking effect as well.◀

Wet, soiled brakes

Moisture and dirt on the brake rotors and the brake pads result in a decrease in the braking action.

Delayed or poorer braking action must be expected in the following situations:

- When driving in the rain and through puddles.
- After washing the vehicle.
- When driving on roads spread with salt.
- After working on the brakes due to oil or grease residues.
- When driving on soiled roads or offroad.



Poor braking action due to moisture and dirt.

Brake until brakes are dry or clean; clean if necessary. Brake early until the full braking action is available again.◀

Parking your motorcycle

Side stand

- Switch off engine.

 If the ground is soft or uneven, there is no guarantee that the motorcycle will rest firmly on the stand.

Always check that the ground under the stand is level and firm.◀

 The side stand is designed to support only the weight of the motorcycle.

Do not lean or sit on the motorcycle with the side stand extended.◀

- Fold out side stand and park motorcycle.
- If the slope of the road permits, turn the handlebars to the left.
- On slopes point the motorcycle uphill and engage 1st gear.

Center stand

- Switch off engine.

 If the ground is soft or uneven, there is no guarantee that the motorcycle will rest firmly on the stand.

Always check that the ground under the stand is level and firm.◀

 Excessive movements could result in the center stand retracting, and the motorcycle could topple as a result.

Do not sit on the motorcycle while it is resting on the center stand.◀

- Fold out center stand and jack up motorcycle.
- On a grade, the motorcycle should always face uphill; select 1st gear.

Off-road riding

When driving offroad

Rims

 As a touring Enduro model, this motorcycle has also been designed for light offroad use on unpaved roads. However, heavier offroad use can result in damage to the standard cast aluminum rims.

For heavier offroad use, use the cross-spoke wheels available as optional equipment.◀

After driving offroad

BMW Motorrad recommends that the following be observed after driving offroad:

Tire inflation pressure

 A tire inflation pressure reduced for offroad driving leads to poorer handling of the motorcycle on paved roads and can result in accidents.

Ensure proper tire inflation pressure. ◀

Brakes

 When the motorcycle is ridden on loose surfaces or muddy roads, the brakes may fail to take effect immediately because of dirt or moisture on the disks or brake pads.

Brake early until the brakes are braked clean. ◀

 Driving on unpaved or dirty roads leads to increased brake pad wear.

Check the brake pad thickness more often and replace the brake pads sooner. ◀

Spring preload and damping

 Spring preload and damping values that have been changed for offroad use reduce handling characteristics on paved surfaces.

Before returning to on-road use, reset correct spring preload and correct damping. ◀

Rims

BMW Motorrad recommends checking the rims for possible damage after riding offroad.

Air cleaner insert

 Engine damage due to soiled air filter insert.

When driving in dusty terrain, check air filter insert for soiling at short intervals and clean or replace if necessary. ◀

Use under very dusty conditions (deserts, savannas, etc.) requires the use air cleaner inserts specially developed for these kinds of applications.

Refueling

Fuel specifications

For optimal fuel economy, the gasoline should be sulfur-free or very low in sulfur content.

 Leaded fuel will destroy the catalytic converter.

Do not refuel with leaded gasoline or gasoline with metallic additives, e. g. manganese or iron. ◀

 Ethanol E85 might damage the engine and fuel supply system.

Do not refuel with E85, i.e. fuel with an ethanol content of 85 %, or with Flex Fuel. ◀

- Fuels with a maximum ethanol content of 10 %, i. e., E10, may be used for refueling.



Recommended fuel quality

Super unleaded (max. 10 % ethanol, E10)
89 AKI (95 ROZ/RON)
89 AKI



Alternative fuel quality

Regular unleaded (restrictions with regard to power and fuel consumption. If the engine should for example be operated with 91 RON in countries with lower fuel quality, the motorcycle must be respectively programmed first by your authorized BMW Motorrad retailer.)
87 AKI (91 ROZ/RON)
87 AKI

Refueling procedure



Fuel is highly flammable. Fire at the fuel tank can result in fire and explosion. Do not smoke. Never bring a naked flame near the fuel tank.◀



Fuel expands when exposed to heat. When the tank is overfilled, fuel can escape and get onto the road. This results in a danger of falling. Do not overfill the fuel tank.◀



Fuel attacks plastic surfaces, making them cloudy or unattractive. Immediately wipe off plastic parts after contact with fuel.◀

- Make sure ground is level and firm and place motorcycle on side stand.



The available fuel tank volume can only be optimally used with the vehicle standing on the side stand.◀

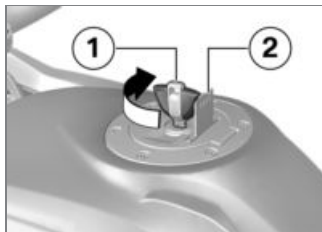

- Open protective cap **2**.
- Unlock cap of fuel tank **1** with ignition key by turning it clockwise, and fold it up.



- Do not fill the tank past the bottom edge of the filler neck.

▶ When refueling after running on reserve, make sure that you top up the tank to a level above reserve, as otherwise the sensor will not be able to register the new level and the fuel warning lamp will not be switched off.◀

▶ The "usable fuel quantity" indicated in the Technical data is the fuel quantity, which can be refueled, if the fuel tank was completely emptied, i.e., if the engine dies off due to lack of fuel.◀



Usable fuel quantity

Approx. 5.3 gal (Approx. 20 l)



Reserve fuel quantity

Approx. 1.1 gal (Approx. 4 l)

- Press fuel tank cap down firmly to close.
- Remove key and close protective cap.

Securing motorcycle for transport

- Protect all component surfaces against which straps are routed against scratching. For example, use adhesive tape or soft cloths.



The motorcycle can tip away to the side and fall over.

Secure motorcycle against tipping away to the side, preferably with the help of a second person.◀

- Push motorcycle onto transport surface, and do not place on side stand or center stand.

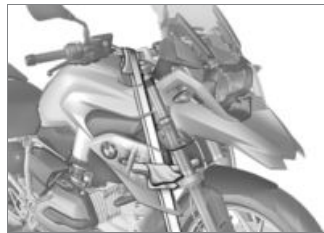

Components can be damaged.

Do not pinch components, e.g. brake lines or wiring harnesses.◀

- Fasten front straps to both sides of the handlebars.

- Guide straps through leading link and then tension.



- Fasten rear straps on both sides to the passenger foot-pegs and then tighten them.
- Tension all straps evenly; the motorcycle should be pulled down against its springs with the suspension compressed as much as possible.

Technology in detail

Riding mode	90
Brake system with BMW Motorrad Integral ABS	91
Engine management with BMW Motorrad ASC.....	94
Tire Pressure Control TCP/RDC	95

Riding mode

Selection

In order to adjust the motorcycle to the road condition, one of 5 riding modes can be selected:

- RAIN
- ROAD (standard mode)
- with Pro driving modes^{OE}
- DYNAMIC
- Enduro
- Enduro PRO (if coding plug is installed only)

For each of the 5 riding modes, adapted settings for the ABS and ASC systems and for the throttle response are available.

- with dynamic ESA^{OE}

The Dynamic ESA alignment depends on the selected riding mode as well.

ABS and/or ASC can be switched off in each mode; the following explanations always refer to the activated systems.

Throttle response

- In RAIN and ENDURO modes: restrained
- In ROAD and ENDURO PRO modes: direct
- In DYNAMIC mode: dynamic

ABS

- The rear wheel lift assistant is active in all modes.
- In the RAIN, ROAD and DYNAMIC modes, ABS is aligned to road operation.
- In the ENDURO mode, ABS is aligned to off-road operation using street tires.
- In the ENDURO PRO mode, no ABS control is applied to the rear wheel, if the foot-brake lever is actuated. ABS

is aligned to off-road operation using massive-bar tires.

ASC

- The front wheel lift assistant is active in all modes.
- In the RAIN, ROAD and DYNAMIC modes, ASC is aligned to road operation.
- In the ENDURO, and ENDURO PRO modes, ASC is aligned to off-road operation.

- with dynamic ESA^{OE}

Dynamic ESA

- In the RAIN, ROAD and DYNAMIC modes, damping variants HARD, NORMAL and SOFT can be selected.
- RAIN mode default setting: SOFT
- ROAD mode default setting: NORMAL
- DYNAMIC mode default setting: HARD

- In the ENDURO and ENDURO PRO modes, damping variants HARD and SOFT can be selected.
- ENDURO mode default setting: SOFT
- ENDURO PRO mode default setting: HARD

Switchover

- with Pro driving modes^{OE}

The driving modes can only be changed while driving under the following condition:

- No drive torque at rear wheel
- No brake pressure in the brake system.

This operating mode is active when the motorcycle is stopped with the ignition switched ON. As an alternative, the following steps must be carried out:

- Turn back throttle grip
- Do not actuate brake lever
- Actuate clutch.

First the desired riding mode is preselected. The switchover does not take place until the affected systems are in the required state.

The selection menu does not disappear in the display until the driving mode has been switched over.

Brake system with BMW Motorrad Integral ABS

Partially integral brake

Your motorcycle is equipped with a partially integral brake configuration. Both front and rear brakes are applied simultaneously when you pull the handbrake lever. The footbrake lever acts only on the rear brake.

The BMW Motorrad Integral ABS adapts the braking force distribution between the front and rear wheel brake to the loading of the motorcycle during braking with ABS control.



Spinning of the rear wheel with the front brake applied (Burn Out) is prevented by the integral function. The result may be damage to the rear wheel brake and the clutch.

Do not attempt Burn Outs. ◀

How does ABS work?

The maximum braking force that can be transferred to the road surface is partially dependent on the friction coefficient of the road surface. Gravel, ice, snow and wet roads offer a considerably lower friction coefficient than a dry, clean asphalt surface. The poorer the friction coefficient of the road surface is, the longer the braking distance will be.

If the maximum transferable braking force is exceeded when the rider increases the brake pressure, the wheels begin to lock and driving stability is lost, and a fall can result. Before this situation occurs, ABS is activated and the brake pressure is adjusted to the maximum transferable braking force. This enables the wheels to continue to turn and maintains driving stability regardless of the road surface condition.

What happens when rough roads are encountered?

Bumpy or rough roads can briefly lead to a loss of contact between the tires and the road surface, until the transferable braking force is reduced to zero. If braking is carried out in this situation, ABS must reduce the brake pressure to ensure driv-

ing stability when restoring contact to the road. At this point in time, the BMW Motorrad Integral ABS must assume extremely low friction coefficients (gravel, ice, snow) so that the running wheels turn in every imaginable case and the driving stability is ensured. After detecting the actual conditions, the system adjusts the optimum brake pressure.

How is the BMW Motorrad Integral ABS noticeable to the rider?

If the ABS system must reduce the braking forces due to the conditions described above, then vibrations can be felt at the handbrake lever.

If the handbrake lever is pulled, then braking pressure is built up at the rear wheel with the integral function. If the footbrake lever is first actuated after this, the brake pressure already built up can be

felt earlier than the counter-pressure, than when the footbrake lever is actuated before or together with the handbrake lever.

Lifting off rear wheel

However, during extremely heavy and rapid deceleration it is possible that the BMW Motorrad Integral ABS will not prevent the rear wheel from lifting off the ground. In these cases, the motorcycle can also flip end over end.



Heavy braking can lead to the rear wheel lifting off the ground.

When braking, bear in mind that the ABS control cannot always be relied on to prevent the rear wheel from lifting off the ground.◀

What are the design characteristics of the BMW Motorrad Integral ABS?

The BMW Motorrad Integral ABS ensures driving stability on any surface within the limits of driving physics. The system is not optimized for special requirements resulting under extreme weather conditions offroad or on the racetrack. Handling should be adopted to driving skills and road conditions.

Special situations

To detect the tendency of the wheels to lock up, the speeds of the front and rear wheel are compared. If implausible values are detected over a longer period of time, the ABS function is deactivated for safety reasons and an ABS fault is indicated. The condition for a fault code is the completed self-diagnosis.

In addition to problems on the BMW Motorrad Integral ABS, unusual driving conditions can also lead to a fault code:

- Heating up on the main or auxiliary stand at idle or with gear engaged
- Rear wheel locked-up for an extended period by engine braking effect, e.g. when riding downhill on slippery surfaces

Should a fault code occur due to an unusual driving condition, the ABS function can be reactivated by switching the ignition off and then on again.

How important is regular maintenance?

 Any technical system is always only as good as its maintenance condition.

To ensure that the BMW Motorrad Integral ABS is in a properly maintained condition, it

is vital that the specified service intervals are kept to. ◀

Reserves for safety

But remember: the potentially shorter braking distances which BMW Motorrad Integral ABS permits must not be used as an excuse for careless riding. ABS is primarily a means of ensuring a safety margin in genuine emergencies.

 Be careful in curves. When you apply the brakes in a curve, the motorcycle's weight and momentum take over and even BMW Motorrad ABS is unable to counteract their effects. The rider is always responsible for adapting his/her driving style. Do not reduce the additional safety provided with risky driving. ◀

Engine management with BMW Motorrad ASC

How does ASC work?

BMW Motorrad ASC compares the wheel speeds of the front and rear wheels. From the speed difference the slip, and with it the stability reserves on the rear wheel are determined. When a slip limit is exceeded, the engine torque is adapted by the engine management system.

What are the design characteristics of the BMW Motorrad ASC?

The BMW Motorrad ASC is an assistance system for the rider and is designed for driving on public roads. Especially in at the limits of driving physics, the rider has a considerable influence on the control options of the ASC

(shifting weight in curves, loose loads).

The ENDURO riding mode should be activated when driving off-road. In this mode the controlling intervention by the ASC is carried out later, enabling controlled drifting.

The system is not optimized for special requirements resulting under extreme weather conditions off-road or on the racetrack. ASC BMW Motorrad can be deactivated for these cases.



Even with ASC, the laws of physics cannot be overridden. The rider is always responsible for adapting his/her driving style.

Do not reduce the additional safety provided with risky driving. ◀

Special situations

As lean angles increase, acceleration potential is also progressively restricted by the laws of physics. This can result in delayed acceleration when coming out of very tight curves.

To detect spinning or slipping away of the rear wheel, the speeds of the front and rear wheel are compared. If implausible values are detected over a longer period of time, the ASC function is deactivated for safety reasons and an ASC fault is indicated. The condition for a fault code is the completed self-diagnosis.

In the following unusual driving conditions, the BMW Motorrad ASC can be automatically deactivated.

Unusual driving conditions:

- Driving on the rear wheel (wheelie) for a longer period with ASC deactivated.
- Rear wheel spinning in place with front brake engaged (burn out).
- Heating up on the main or auxiliary stand at idle or with gear engaged.

The ASC is reactivated by switching the ignition on and off and then driving at a speed above 6 mph (10 km/h).

With extremely massive-bar tires, an ASC intervention can occur before the optimum propulsion is achieved due to the greater slip involved. In these cases the BMW Motorrad ASC should be deactivated.

If the front wheel loses contact to the ground during extreme acceleration, the ASC reduces the engine torque until the front wheel touches the ground again. In this case, BMW Motorrad recommends turning back the throttle grip somewhat to achieve a stable driving state again as quickly as possible.

On a slippery surface, the throttle grip should never be suddenly turned back completely without pulling the clutch at the same time. The engine braking torque can cause the rear wheel to block, resulting in an unstable driving state. This case cannot be controlled by the BMW Motorrad ASC.

Tire Pressure Control TCP/RDC

- with Tire Pressure Control (TPC/RDC)^{OE}

Function

A sensor is located in each tire, which measures the air temperature and the inflation pressure inside the tire and sends these values to the control unit.

The sensors are equipped with a centrifugal controller, which does not enable the transmission of the measured values until after a speed of approx. 18 mph (30 km/h) is exceeded for the first time. Before initial reception of the tire inflation pressure, -- is shown in the display for each tire. The sensors continue to transmit the measured values for approx. 15 minutes after the vehicle comes to a stop.

The control unit can manage four sensors, and as a result two sets

of wheels with TPC/RDC sensors can be driven. If a TPC/RDC control unit is installed, however the wheels have no sensors, then a fault code is output.

Tire inflation pressure ranges

The TCP/RDC control unit distinguishes between 3 inflation pressure ranges matched to the motorcycle:

- Inflation pressure within the permissible tolerance
- Inflation pressure at the limits of the permissible tolerance
- Inflation pressure outside the permissible tolerance

Temperature compensation

The tire inflation pressure is temperature dependent, i.e. it increases or decreases together with the tire temperature. The tire temperature is dependent on

the outside temperature and on the driving style and duration. The tire inflation pressures are shown temperature-compensated in the multifunction display; they refer to a tire temperature of 68 °F (20 °C). No temperature compensation takes place in the inflation pressure testers at filling stations, meaning that the measured tire inflation pressure varies according to tyre temperature. As a result, the pressure figures indicated by the gauges at filling stations will usually vary from those appearing in the multifunction display.

Adjusting inflation pressure

Compare the TPC/RDC value in the multifunction display with the value on the back cover of the Rider's Manual. The difference between the two values must be

compensated with the air pressure tester at the filling station.

Example: according to the Rider's Manual, the tire inflation pressure is to be 36.3 psi (2.5 bar), however 33.4 psi (2.3 bar) is shown in the multifunction display. This means the tires are underinflated by 2.9 psi (0.2 bar). The tester at the filling station indicates 34.8 psi (2.4 bar). This value must be increased by 2.9 psi (0.2 bar) to 37.7 psi (2.6 bar) in order to produce the correct tire inflation pressure.

Maintenance

General instructions.....	98
Onboard tool kit	98
Engine oil	99
Brake system	100
Coolant	104
Clutch	105
Wheel rims and tires	106
Wheels	106
Front wheel stand	112
Bulbs	113
Air filter	118
Jump-starting.....	119
Battery.....	120
Fuses	124

General instructions

The "Maintenance" chapter describes work involving the checking and replacement of wear parts that can be performed with a minimum of effort.

If special tightening torques are to be taken into account for assembly, these are listed. An overview of all required tightening torques is contained in the chapter "Technical Data".

Further information about maintenance and repair work can be obtained on DVD through your authorized BMW Motorrad retailer.

Special tools and thorough specialized knowledge are required to carry out some of the work. If you are in doubt, consult an authorized workshop, preferably your authorized BMW Motorrad retailer.

Onboard tool kit

Standard tool kit

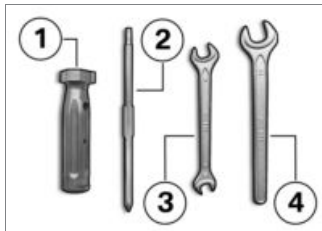

- 1** Screwdriver handle
 - Use with screwdriver bit.
 - Top up engine oil (➡ 100).
- 2** Reversible screwdriver insert
 - Phillips PH1 and Torx T25
 - Remove bulb for front and rear turn indicator (➡ 116).
 - Remove battery cover (➡ 122).

- 3** Open-ended wrench
 - Wrench size: 8/10 mm
 - Remove battery (➡ 122).
- 4** Open-ended wrench
 - Wrench size: 14
 - Adjust mirror arm (➡ 70).

Service tool kit

– with service toolkit^{OA}

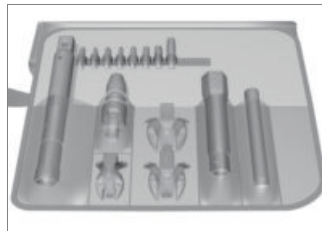

For more extensive service operations (such as wheel removal and installation), BMW Motorrad has put together a service tool kit matched to your motorcycle. You

can purchase this tool kit from your authorized BMW Motorrad retailer.

Engine oil

Checking engine oil level



The oil level varies with the temperature of the oil. The higher the temperature, the higher the level of oil in the sump. Checking the oil level with the engine cold or after a short trip leads to misinterpretations of the oil fill quantity.

To ensure that the display of the engine oil level is correct, only check the oil level with the engine at operating temperature. ◀

- Switch off engine at operating temperature.
- Make sure ground is level and firm and place motorcycle on center stand.

- Wait five minutes to allow oil to drain to the oil pan.

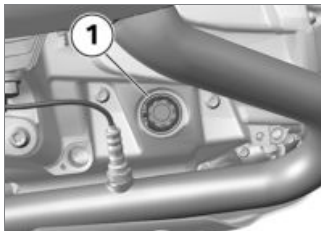

- Read the oil level in the display **1**.



 Specified level of engine oil

Between MIN and MAX marking

If the oil level is below MIN mark:

- Top up engine oil (➡ 100).

If oil level is above MAX mark:

- Have the oil level corrected at an authorized service facility, preferably an authorized BMW Motorrad dealer.

Topping up engine oil

- Park the motorcycle, ensuring that the support surface is firm and level.

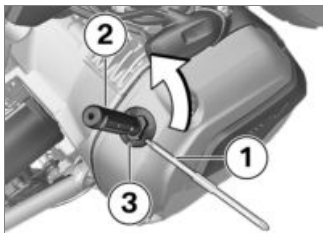

- Clean area adjacent to oil fill location.
- To be able to apply force more easily, insert the interchangeable screwdriver bit **1**, Torx end first, into the screwdriver handle **2** (from motorcycle toolkit).
- Locate the specified tool from the toolkit on the engine oil filler plug **3** and turn counter-clockwise.

- Checking engine oil level (▣▣▣▣ 99).



Both too little and too much engine oil can lead to engine damage.

Always make sure that the oil level is correct.◀

- Add engine oil up to specified level.



Engine oil, quantity for topping up

max 1 quarts (max 0.95 l) (Difference between MIN and MAX)

- Checking engine oil level (▣▣▣▣ 99).
- Install sealing plug **3** of engine oil fill location.

Brake system

Checking brake operation

- Actuate the handbrake lever.
 - » Pressure point must be clearly perceptible.
- Actuate the footbrake lever.
 - » Pressure point must be clearly perceptible.

If no clear pressure points are perceptible:



Incorrect working practices endanger the reliability of the brakes.

Have all work on the brake system carried out by specialists.◀

- Have the brakes checked at an authorized workshop, preferably an authorized BMW Motorrad retailer.

Check front brake pad thickness

- Make sure ground is level and firm and park motorcycle.



- Visually inspect left and right brake pads to determine their thickness. Viewing direction: between wheel and front suspension toward brake pads **1**.

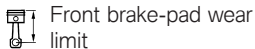

0.04 in (1.0 mm) (Only friction material without carrier plate. Wear markings (grooves) must be clearly visible.)

If the wear indicators are no longer clearly visible:



⚠ Dropping below the minimum pad thickness leads to reduced braking performance and may result in damage to the brakes.

In order to ensure the operating reliability of the brake system,

make sure that the brake pads are not worn beyond their minimum thickness. ◀

- Have the brake pads replaced at an authorized service facility, preferably an authorized BMW Motorrad dealer.

Checking rear brake pad thickness

- Make sure ground is level and firm and park motorcycle.



- Conduct a visual inspection of the brake pad thickness. Viewing direction: between splash

guard and rear wheel toward brake pads **1**.

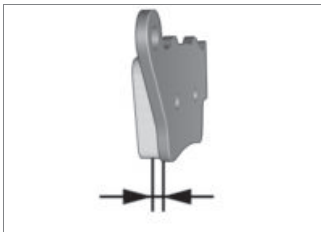

Rear brake-pad wear limit

0.04 in (1.0 mm) (Only friction material without carrier plate.)

If wear limit is reached:



Dropping below the minimum pad thickness leads to reduced braking performance and may result in damage to the brakes.

In order to ensure the operating reliability of the brake system,

make sure that the brake pads are not worn beyond their minimum thickness. ◀

- Have the brake pads replaced at an authorized service facility, preferably an authorized BMW Motorrad retailer.

Checking front brake fluid level



A low fluid level in the brake reservoir can allow air to penetrate the brake system. This significantly reduces braking efficiency.

Check brake fluid level regularly. ◀

- Make sure ground is level and firm and place motorcycle on its center stand.
- Move handlebars into straight-ahead position.



- Check brake fluid level in front brake-fluid reservoir **1**.



The brake fluid level in the brake-fluid reservoir drops due to brake pad wear. ◀



Front brake fluid level

Brake fluid, DOT4

The brake fluid level must not fall below the MIN mark. (Brake-fluid reservoir horizontal, motorcycle standing upright)

If brake fluid level falls below the approved level:

- Have the defect corrected as soon as possible by an authorized workshop, preferably an authorized BMW Motorrad retailer.

Checking rear brake fluid level

 A low fluid level in the brake reservoir can allow air to penetrate the brake system. This significantly reduces braking efficiency. Check brake fluid level regularly.◀

- Make sure ground is level and firm and place motorcycle on its center stand.



- Check level of brake fluid in rear brake-fluid reservoir **1**.

 The brake fluid level in the brake-fluid reservoir drops due to brake pad wear.◀

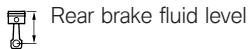

Rear brake fluid level

Brake fluid, DOT4

The brake fluid level must not fall below the MIN mark. (Brake-fluid reservoir horizontal, motorcycle standing upright)

If brake fluid level falls below the approved level:

- Have the defect corrected as soon as possible by an authorized workshop, preferably an authorized BMW Motorrad retailer.

Coolant

Checking coolant level

- Make sure ground is level and firm and park motorcycle.

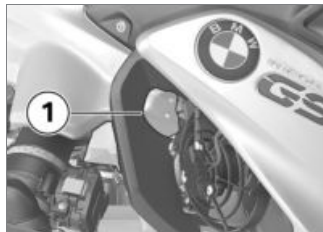

 Danger of burns on hot engine.

Maintain distance from hot engine.

Do not touch hot engine. ◀

- Read off coolant level on expansion tank **1**.

If coolant level drops below approved level:

- Add coolant.

Topping up coolant

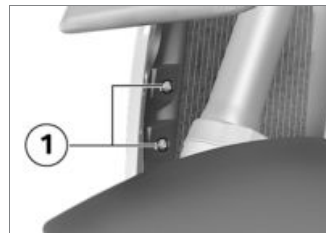

- Remove screws **1**.

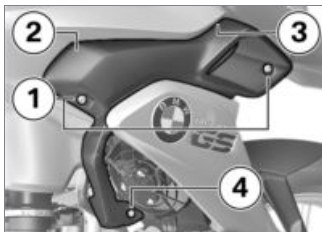

- Remove screws **1**.
- Remove the side panels at positions **2**, **3** and **4** from the holders.



- Open cap **1** of coolant expansion tank and add coolant up to specified level.

- Check coolant level (→ 104).
- Close cap of coolant expansion tank.

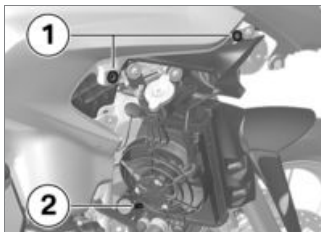

- Insert side panel into mounts **1** and **2**.



- Install screws **1**.

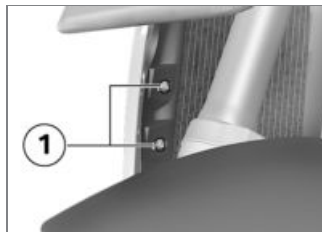

- Install screws **1**.

Clutch

Check clutch function

- Pull back the clutch lever.
 - » Pressure point must be clearly perceptible.
- If no clear pressure point can be felt:

- Have the clutch checked by an authorized workshop, preferably an authorized BMW Motorrad retailer.

Wheel rims and tires

Check wheel rims

- Make sure ground is level and firm and park motorcycle.
- Subject wheel rims to visual inspection for defects.
- Have damaged rims checked and, if necessary, replaced by a specialist service facility, preferably an authorized BMW Motorrad retailer.

Checking tire tread depth



The handling of your motorcycle can already change for the worse before the legally prescribed minimum tread depth is reached.

Have tires replaced even before the minimum tread depth is reached. ◀

- Make sure ground is level and firm and park motorcycle.

- Check tire tread depth in main tread grooves with wear indicators.

 Tread wear marks are integrated into the main grooves on every tire. If the tire tread has worn down to the level of the marks, the tire is completely worn. The locations of the marks are indicated on the edge of the tire, e.g. by the letters TI, TWI or by an arrow. ◀

When the minimum tread depth is reached:

- Replace the worn tires.

Checking spokes

– with cross-spoke wheels^{OE}

- Make sure ground is level and firm and park motorcycle.
- Sweep across spokes with a screwdriver handle or similar item, paying attention to the sound that they emit as you proceed.

If the tone does not remain consistent:

- Have spokes checked by an authorized service facility, preferably an authorized BMW Motorrad dealer.

Wheels

Tire recommendation

For every size of tire, BMW Motorrad has tested and approved certain makes as roadworthy. BMW Motorrad cannot evaluate the suitability of other tires, and can therefore take no responsibility for their driving safety.

BMW Motorrad recommends only using the tires tested and approved by BMW Motorrad. Extensive information is available at your authorized BMW Motorrad retailer or on the Internet at "www.bmw-motorrad.com".

Affect of wheel sizes on chassis control systems

The wheel sizes play a major role in the ABS and ASC chassis control systems. Especially the diameter and width of the wheels are stored in the control unit as the basis for all necessary calculations. A change in these sizes due to conversion to others than the wheels installed as standard equipment can seriously affect the control comfort of these systems.

The sensor wheels required for wheel speed detection must also match the control systems installed and may not be replaced. If you want to equip your motorcycle with different wheels, please speak to a specialist service facility, and preferably a BMW Motorrad retailer. In some cases the data stored in the control units can be adapted to the new wheel sizes.

TPC/RDC sticker

– with Tire Pressure Control (TPC/RDC)^{OE}

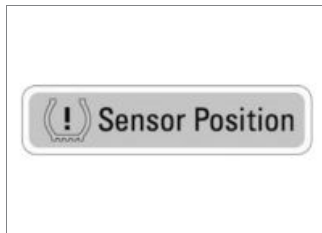

 If tires are inexpertly removed, the RDC sensors may be damaged. Inform the authorized BMW Motorrad retailer or the specialist service facility on the fact that the wheel is equipped with a RDC sensor. ◀

On motorcycles equipped with TPC/RDC, a corresponding sticker is located on the wheel rim at the position of the TPC/

RDC sensor. During a tire change it must be ensured that the TPC/RDC sensor is not damaged. Inform the BMW Motorrad retailer or the authorized workshop of the TPC/RDC sensor.

Removing front wheel

- Make sure ground is level and firm and place motorcycle on its center stand.

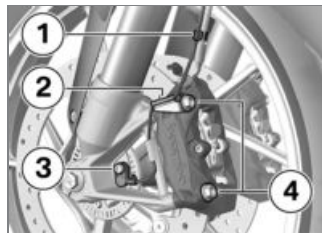

- Detach wheel speed sensor lead from retaining clips **1** and **2**.

- Remove screw **3** and take wheel speed sensor out of bore.
- Mask off areas of wheel rim that could be scratched in the process of removing the brake calipers.

 Once the calipers have been removed, there is a risk of the brake pads being pressed together to the extent that they cannot be slipped back over the brake rotor on reassembly.

Do not operate the handbrake lever when the brake calipers have been removed.◀

- Remove securing screws **4** of left and right brake calipers.

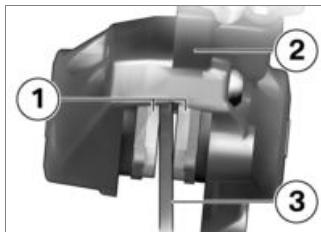

- Push brake pads **1** slightly apart by turning the brake caliper **2** back and forth against the brake rotor **3**.
- Carefully pull brake calipers back and outward to remove them from the brake rotors.
- Raise front of motorcycle, preferably using a BMW Motorrad front wheel stand, continuing until the wheel rotates freely.
- Mounting front wheel stand (▶▶ 112).



- Remove right-hand axle clamping screw **1**.

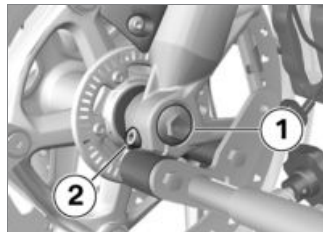

- Remove screw **1**.
- Remove left axle clamping screw **2**.

- Slightly press the quick-release axle inward for a better grip on the right side.

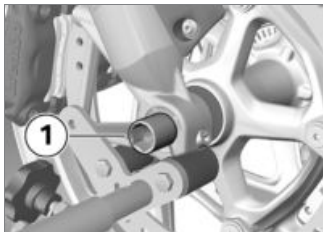

- Pull quick-release axle **1** out while supporting the front wheel.
- Place front wheel down and roll it forward out of the front suspension.

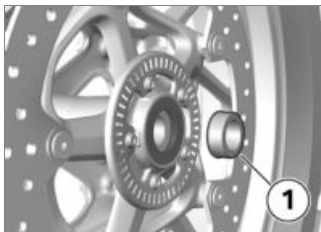

- Remove spacer bushing **1** from the wheel hub.

Installing front wheel

 Malfunctions may occur during control interventions by ABS or ASC if a wheel other than the standard wheel is installed.

Please see the information on the effect of wheel sizes on the ABS and ASC chassis control systems at the beginning of this chapter. ◀

 Threaded fasteners not tightened to the specified torque can work loose or their threads can suffer damage. Always have the tightening torques checked by a specialized workshop, preferably an authorized BMW Motorrad retailer. ◀

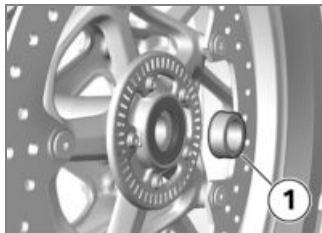

- Mount spacing bushing **1** on left side in wheel hub.

 The front wheel must be installed right way round to rotate in the correct direction. Observe the direction of rota-

tion arrows on the tires or on the rim. ◀

- Roll front wheel into front suspension.

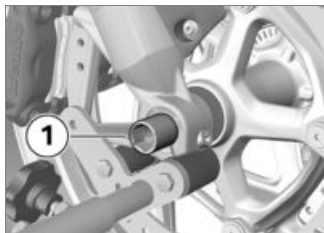

- Lift front wheel and install quick-release axle **1**.
- Remove front wheel stand and firmly compress front forks. Do not actuate handbrake lever at the same time.
- Mounting front wheel stand (▶▶ 112).

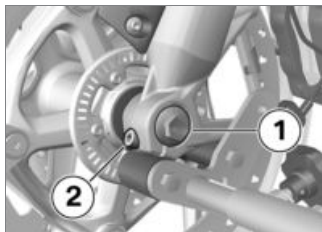

- Install screw **1** with specified torque. Brace quick-release axle on the right side at the same time.



Quick-release axle in telescopic fork

22 lb/ft (30 Nm)

- Tighten left axle clamping screw **2** with appropriate torque.



Clamping screw for quick-release axle in telescopic fork

14 lb/ft (19 Nm)



- Tighten the right-hand axle clamping screw **1** with the specified torque.



Clamping screw for quick-release axle in telescopic fork

14 lb/ft (19 Nm)

- Remove front wheel stand.
- Slide the brake calipers on the left-hand and right-hand side onto the brake rotors.

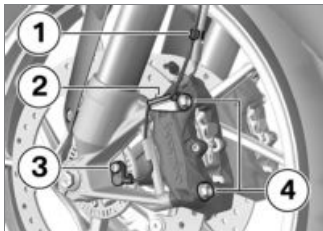

- Install securing screws **4** on left and right with specified torque.

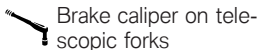

Brake caliper on telescopic forks

28 lb/ft (38 Nm)

- Remove adhesive tape from wheel rim.

⚠ Braking efficiency is impaired if the brake pads are not correctly bedded against the disks.

Before driving off, check that the braking effect kicks in without any delay. ◀

- Engage the brakes repeatedly, continuing until the brake pads seat against the rotors.
- Locate wheel speed sensor lead in the retaining clips **1** and **2**.
- Insert wheel speed sensor in bore and install screw **3**.



Wheel speed sensor on bevel gears

6 lb/ft (8 Nm)

Removing rear wheel

- Make sure ground is level and firm and place motorcycle on its center stand.
- Shift into first gear.



Risk of skin burns from hot exhaust system.

Do not touch hot parts of the exhaust system. ◀

- Let rear muffler cool down.



- Remove bolts **1** of rear wheel, holding wheel as you do so.
- Roll rear wheel out toward rear.

Install rear wheel



Malfunctions may occur during control interventions by ABS or ASC if a wheel other than the standard wheel is installed.

Please see the information on the effect of wheel sizes on the ABS and ASC chassis control systems at the beginning of this chapter. ◀

 Threaded fasteners not tightened to the specified torque can work loose or their threads can suffer damage. Always have the tightening torques checked by a specialized workshop, preferably an authorized BMW Motorrad retailer. ◀

- Place rear wheel on rear wheel support.



- Install wheel studs **1** with specified torque.



Tighten rear wheel on wheel flange

Tightening sequence: diagonally

44 lb/ft (60 Nm)

Front wheel stand

Mounting front wheel stand

 The BMW Motorrad front wheel stand is not designed for holding motorcycles without a center or other auxiliary stands. A motorcycle standing on the front wheel stand and the rear wheel alone can fall over.

Place the motorcycle on the center stand or an auxiliary stand before lifting it with the BMW Motorrad front wheel stand. ◀

- Make sure ground is level and firm and place motorcycle on center stand.
- Use basic stand with front wheel mount. The basic stand and its accessories are available through your authorized BMW Motorrad retailer.

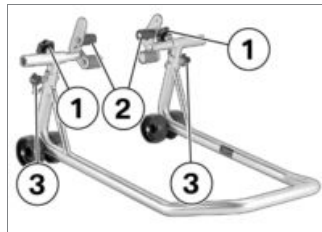

- Loosen adjustment screws **1**.
- Push the two mounts **2** outward, continuing until the front suspension fits between them.
- Use locating pins **3** to set front wheel stand to desired height.

- Center front wheel stand relative to front wheel and push it against front axle.

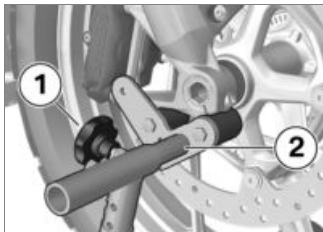

- Align two mounts **2** so that front suspension rests securely on them.
- Tighten adjustment screws **1**.

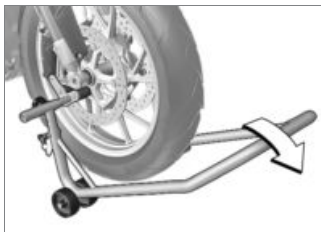

! If the motorcycle is resting on the center stand: The motorcycle is raised too far at the front, the center stand lifts off the ground and the motorcycle can tip over to the side. When raising the vehicle, make sure that the center stand remains on the ground.◀

- Apply uniform pressure to push front wheel stand down and raise motorcycle.

Bulbs

Replacing bulbs for dipped and main-beam headlights

▶ The alignment of connector, spring wire strap and bulb may differ from that shown in the following illustrations.◀

- Make sure ground is level and firm and park motorcycle.
- Switch off ignition.

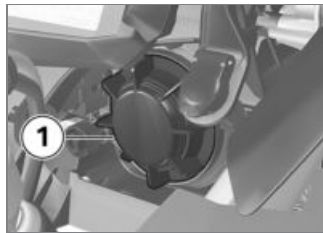

- Remove cover **1** by turning it counterclockwise to replace low-beam headlight bulb.



- Remove cover **1** by turning it counterclockwise to replace high-beam headlight bulb.



- Disconnect plug **1**.



- Remove spring strap **1** from detent and fold to side.
- Remove bulb **2**.
- Replace defective bulb.

 Bulbs for low-beam headlight

H7 / 12 V / 55 W

– with LED headlights^{OE}

LED<

 Bulb for high-beam headlight

H7 / 12 V / 55 W

 Bulb for high-beam headlight

– with LED headlights^{OE}

LED<

- To protect the glass against soiling, only grasp the bulb by the base.



- Insert bulb **2** while ensuring that the lug **3** is in the correct position.

 The alignment of the bulb may differ from the illustration.◀

- Insert spring clip **1** into catch.



- Insert plug **1**.
- Position cover panel and install it by turning clockwise.

Replacing bulb for parking light

- Make sure ground is level and firm and park motorcycle.
- Switch off ignition.



- Remove cover panel **1** by turning counterclockwise.

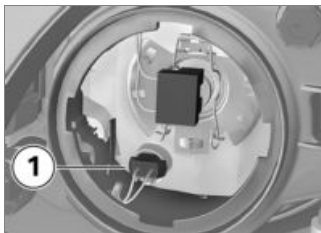

- Remove bulb holder **1** from the light housing.



- Remove bulb **1** from the socket.
- Replace defective bulb.

 Bulb for parking light

W5W / 12 V / 5 W

– with LED headlights^{OE}

LED<

- To prevent contaminants from being deposited on the glass surface, always use a clean, dry cloth to hold the bulb.



- Insert bulb **1** in bulb socket.

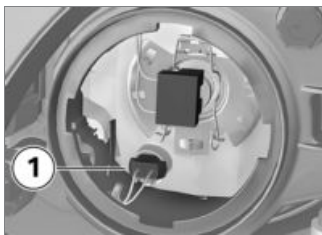

- Insert bulb holder **1** into the light housing.
- Position cover panel and install it by turning clockwise.

Replacing bulb for front and rear turn indicator

- Make sure ground is level and firm and park motorcycle.
- Switch off ignition.



- Remove screw **1**.



- Pull glass on screw connection side out of light housing.

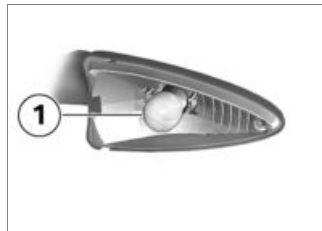

- Remove bulb **1** from light housing by turning it counterclockwise.

- Replace defective bulb.

 Bulbs for flashing turn indicators, front

RY10W / 12 V / 10 W

 Bulbs for flashing turn indicators, rear

RY10W / 12 V / 10 W

- To prevent contaminants from being deposited on the glass surface, always use a clean, dry cloth to hold the bulb.

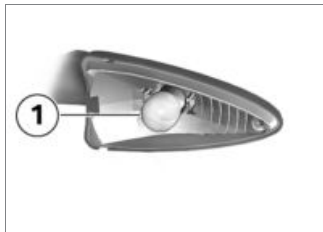

- Install bulb **1** by turning clockwise in light housing.



- Insert inside end of lens into light housing and close.



- Install screw **1**.

Replacing LED tail light

The LED tail light can only be completely replaced.

- Please contact a specialist service facility for this purpose, preferably an authorized BMW Motorrad retailer.

Replacing the LED headlight

- with LED headlights^{OE}
- LED headlights can be completely replaced only. Please contact a specialist service facility for this purpose, preferably an authorized BMW Motorrad retailer.◁

Replace additional LED headlight

- with additional LED headlight^{OA}

The LED additional headlights can only be completely replaced; it is not possible to replace individual LEDs.

Please contact a specialized workshop, preferably an authorized BMW Motorrad retailer.

Air filter

Replacing air cleaner insert



- Remove rider's seat (→ 72).
- Remove screws **1** and screws **2**.
- Remove center fairing panel.

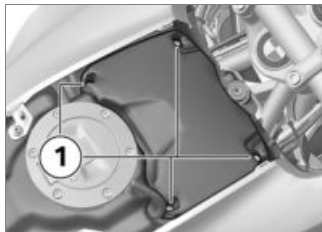

- Remove screws **1**.
- Remove air filter cover.

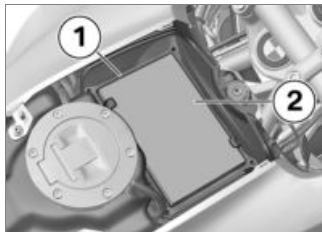

- Remove frame **1**.
- Remove air cleaner insert **2**.

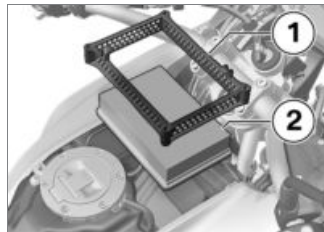

- Clean air filter insert **2** or replace if necessary.
- Insert air filter insert **2** and frame **1**.

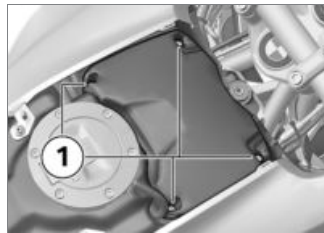

- Lay on air filter cover.
- Install screws **1**.

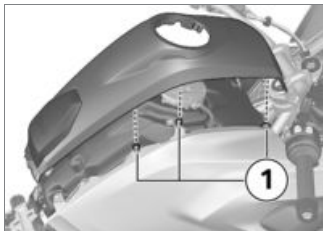

- Position center fairing panel, while paying attention to connections **1** to the side panels.



- Install screws **1** and screws **2**.
- Install rider's seat (►► 72).

Jump-starting

⚠ The wires leading to the power socket do not have a load-capacity rating adequate for jump-starting the engine. Excessively high current can lead to a cable fire or damage to the vehicle electronics.

Do not use the socket to jump-start the engine of the motorcycle.◀

⚠ A short-circuit can result if the crocodile clips of the jump leads are accidentally brought into contact with the motorcycle.

Use only jump leads fitted with fully insulated crocodile clips at both ends.◀

⚠ Jump-starting with a donor battery voltage higher than 12 V can damage the motorcycle electronics.

The battery of the donor vehicle must have a voltage of 12 V.◀

- Park the motorcycle, ensuring that the support surface is firm and level.
- Remove battery cover (►► 122).
- Do not disconnect the battery from the onboard electrical system when jump-starting the engine.

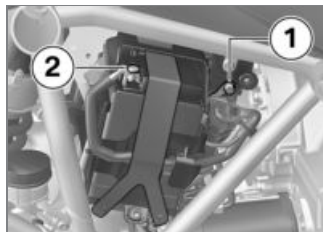

- Begin by connecting one end of the red jump lead to the positive terminal **1** of the discharged battery and the other end to the positive terminal of the donor battery.

▶ If the 12 V battery is installed incorrectly, or if the terminals are exchanged (e.g. when jump-starting), this can result in the fuse for the alternator regulator blowing.◀

- Connect black jump lead to negative terminal of donor battery and then to negative terminal **2** of discharged battery.
- Run engine of donor vehicle during jump-starting procedure.
- Start engine of the vehicle with discharged battery in usual way; if engine does not start, wait a few minutes before repeating the attempt in order to protect the starter motor and donor battery.
- Allow both engines to idle for a few minutes before disconnecting jumper cables.
- Disconnect jumper lead from negative terminal first, then from positive terminal.

▶ To start the engine, do not use start sprays or similar items.◀

- Install rider's seat (▶▶▶ 72).

Battery

Maintenance instructions

Correct battery maintenance combined with proper charging and storage procedures extends the battery's service life, and is also required for warranty claims. Compliance with the points below is important in order to maximize battery life:

- Keep the surface of the battery clean and dry.
- Do not open the battery.
- Do not top up with water.
- Be sure to read and comply with the instructions for charging the battery on the following pages.
- Do not turn the battery upside down.



If the battery is not disconnected, the onboard electronics (clock etc.) will drain the battery. This can cause the battery to run flat. If this happens, warranty claims will not be accepted.

During driving breaks of more than 4 weeks, a trickle-charger should be connected to the battery.◀



BMW Motorrad has developed a trickle-charger specially designed for compatibility with the electronics of your motorcycle. Using this charger, you can keep the battery charged during long periods when the motorcycle is not being used without having to disconnect the battery from the motorcycle's onboard systems. Additional information is available at your authorized BMW Motorrad retailer.◀

Charging connected battery



Charging the connected battery directly at the battery terminals can damage the motorcycle electronics.

To charge the battery via the battery terminals, disconnect the battery first. ◀



If the multifunction display and indicator lamps fail to light up when you switch on the ignition, the battery is completely discharged (battery voltage below 9 V). Attempts to recharge a completely discharged battery through the onboard power socket can damage the motorcycle's electronic systems.

Always charge a completely drained battery directly at the terminals of the disconnected battery. ◀



Charging the battery via the onboard socket is only possible with suitable chargers. Unsuitable chargers can result in damage to the motorcycle electronics.

Use suitable BMW chargers. The correct charger is available through your authorized BMW Motorrad retailer. ◀

- Charge disconnected battery via onboard socket.



The motorcycle's onboard electronics know when the battery is fully charged. The onboard socket is switched off when this happens. ◀

- Comply with operating instructions of charger.



If you are unable to charge the battery via the onboard socket, you may be using a charger that is not compatible with your motorcycle's electronics. In

this case, charge the battery directly at the terminals of the disconnected battery. ◀

Charging disconnected battery

- Charge battery using a suitable charger.
- Comply with operating instructions of charger.
- Once battery is fully charged, disconnect charger's terminal clips from battery terminals.



In the case of longer periods when the motorcycle is not being used, the battery must be recharged regularly. See the instructions for caring for your battery. Always fully recharge the battery before returning it to use. ◀

Removing and installing battery

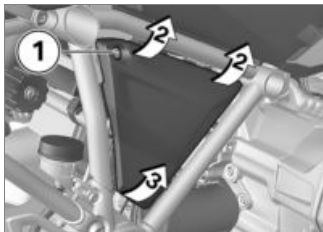

- Switch off ignition.
- Remove screw **1**.
- Pull battery cover at top slightly forward at the positions **2**.
- In order not to damage the battery cover and the mount, remove the battery cover upward at position **3**.

– with anti-theft alarm^{OE}

- Switch off anti-theft alarm system if necessary.◀

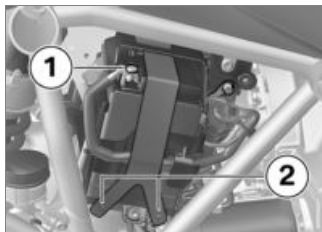

- Remove negative battery cable **1** and rubber strap **2**.



- Pull mounting plate on position **1** outward and remove it upward.

- Slightly lift and remove battery from holder until positive terminal becomes accessible.



- Remove positive battery cable **1** and pull out battery.

◀ If the 12 V battery is installed incorrectly, or if the terminals are exchanged (e.g. when jump-starting), this can result in the fuse for the alternator regulator blowing.◀



- Fasten positive battery cable **1**.
- Slide battery into holder.

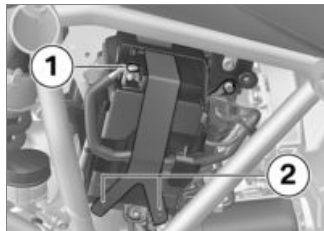

- Fasten negative battery cable **1**.
- Fasten battery with rubber strap **2**.

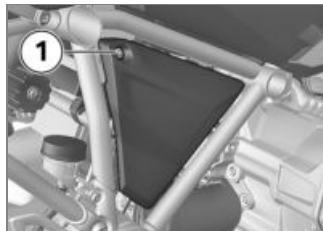

- Install screw **1**.
- Set clock (▶▶▶▶ 47).
- Set date (▶▶▶▶ 48).

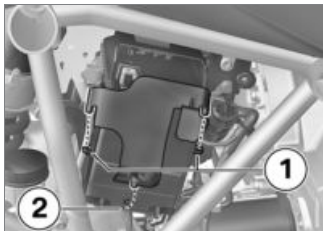

- First, insert mounting plate into supports **1**. Next, press it under the battery at position **2**.



- Insert battery cover into mount **1** and press it into mounts **2**.

Fuses

Replacing fuses

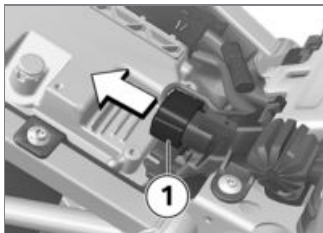

- Switch off ignition.
- Remove rider's seat (▣▣▣ 72).
- Disconnect plug **1**.

⚠ If defective fuses are bridged, this results in a danger of short-circuit and thus a danger of fire.

Replace defective fuses with new fuses.◀

- Consult the fuse assignment diagram and replace the defective fuse.

▶ If the fuses blow frequently, have the electrical system checked by an authorized specialized workshop, preferably an authorized BMW Motorrad retailer.◀

- Install connector **1**.
- Install rider's seat (▣▣▣ 72).

Fuse assignment

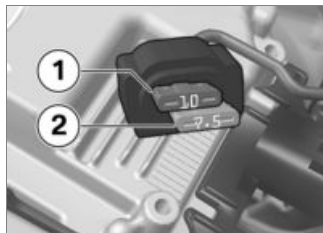

- 1** 10 A
Instrument cluster
Anti-theft alarm system (DWA)
Ignition switch
Diagnostic socket

- 2** 7.5 A
Multifunction switch, left
Tire Pressure Control (TCP/RDC)

Fuse for alternator regulator

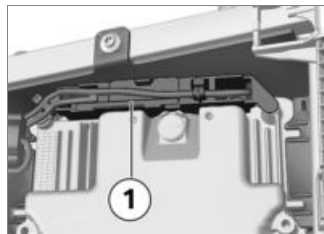

- 1** 50 A
Alternator regulator

Accessories

General instructions.....	126
Onboard power sockets	126
Navigation system	127
Case	131
Topcase	134

General instructions



BMW Motorrad cannot examine or test each product of outside origin to ensure that it can be used on or in connection with BMW motorcycles without constituting a safety hazard. Nor is this guarantee provided when the official approval of a specific country has been granted. Tests conducted by these instances cannot make provision for all operating conditions experienced by BMW motorcycles and, consequently, they are not sufficient in some circumstances.

Use only parts and accessories approved by BMW for your motorcycle. ◀

The safety, function and suitability of the parts and accessory products have been checked extensively by BMW. Therefore, BMW assumes responsibility for these products. BMW shall not

be liable for unapproved parts and accessory products of any kind.

Whenever you are planning modifications, comply with all the legal requirements. The vehicle must not infringe on national road-vehicle construction and use regulations of your country. Your authorized BMW Motorrad retailer offers you qualified advice when choosing genuine BMW parts, accessories and other products.

You will find all BMW Motorrad optional accessories on our website: "www.bmw-motorrad.com".

Onboard power sockets

Connection of electrical devices

- The ignition must be switched on before electrical devices

connected to the power sockets can be operated.

Cable routing

- The cables from the onboard sockets to the auxiliary devices must be routed in such a way that they do not impede the rider.
- Cable routing must not restrict the steering angle and the handling characteristics.
- Cables must not be trapped.

Automatic deactivation

- The onboard sockets are automatically switched off during starting.
- These sockets are switched off approx. 15 minutes after switching off the ignition to reduce the strain on the onboard electrical system. Additional devices with low power consumption are possibly not detected by the vehicle electron-

ics. In these cases, onboard sockets are already switched off shortly after the ignition is switched off.

- In case of insufficient battery voltage, the onboard sockets are switched off to maintain the ability to start the motorcycle.
- If the maximum loadability specified in the technical data is exceeded, the onboard sockets are switched off.

Navigation system

- with preparation for navigation system^{OE}

Securely fastening navigation device

▶ The navigation preparation is suitable for the BMW Motorrad Navigator IV and the BMW Motorrad Navigator V. ◀

▶ The locking system of the Mount Cradle offers no protection against theft. Remove the navigation system and store in a safe place after every drive. ◀

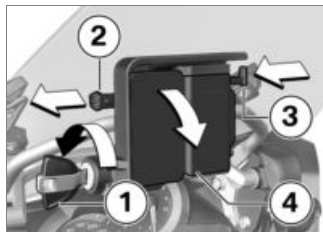

- Turn ignition key **1** counter-clockwise.
- Pull shut-off lock **2** to **left**.
- Press in locking device **3**.
- » Mount Cradle is unlocked and cover **4** can be removed with a rotating movement toward front.

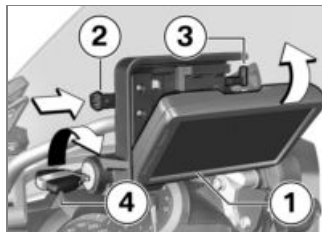

- Mount navigation device **1** in lower area and swing toward rear with a rotating movement.
- » Navigation device audibly engages.
- Slide shut-off lock **2** completely to **right**.
- » Locking device **3** is locked.
- Turn ignition key **4** clockwise.
- » Navigation device is locked and ignition key can be removed.

Removing navigation device and installing cover



Dust and dirt can damage the contacts of the Mount Cradle.

Reinstall the cover after end of each drive. ◀

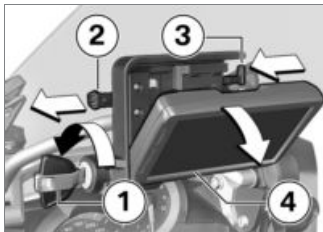

- Turn ignition key **1** counter-clockwise.
- Pull shut-off lock **2** completely to **left**.
- » Locking device **3** is unlocked.
- Slide locking device **3** completely to **left**.

- » Navigation device **4** is unlocked.
- Remove navigation device **4** downward with a tilting movement.

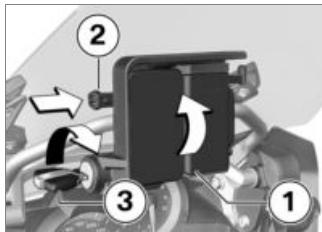

- Mount cover **1** in lower area and swing upward with a rotating movement.
- » Cover audibly engages.
- Slide shut-off lock **2** to **right**.
- Turn ignition key **3** clockwise.
- » Cover **1** is secured.

Operating the navigation system

▶ The following description refers to the Navigator V. The Navigator IV does not offer all options described. ◀

▶ Only the latest version of the BMW Motorrad communication system is supported. A software update may be required for the BMW Motorrad communication system. In this case, please contact your authorized BMW Motorrad retailer. ◀

If BMW Motorrad Navigator is installed, some of its functions can be directly operated from the handlebars using the Multi-Controller.



The Multi-Controller is operated using six motions:

- Turning up and down.
- Short actuation to the left and right.
- Long actuation to the left and right.

Turning the Multi-Controller increases or decreases the volume of a BMW Motorrad communication system connected via Bluetooth on the Compass and Mediaplayer page.

Menu items on the BMW special menu are selected by turning the Multi-Controller.

Short actuation of the Multi-Controller to the left respectively to the right switches between the main pages of the Navigator:

- Map view
- Compass
- Mediaplayer
- BMW special menu
- My motorcycle page

Long actuation of the Multi-Controller corresponds to the activation of certain functions on the Navigator display. These functions are marked with a right arrow or a left arrow above the corresponding touch field.

 The function is triggered by long actuation to the right.

 The function is triggered by long actuation to the left.

In detail, the following functions can be operated:

Map view

- Turning upward: Increase size of map section (Zoom in).
- Turning downward: Decrease size of map section (Zoom out).

Compass page

- Turning increases or reduces volume of a BMW Motorrad communication system connected via Bluetooth.

BMW special menu

- Speak: Repeat last navigation announcement.
- Way point: Save current way point as favorite.
- Navigate home: Starts navigation to the home address (is grayed-out if no home address is set).
- Mute: Switch automatic navigation announcements (off: the top line in the display shows

- a crossed-out lip icon). Navigation announcements can still be output via "Speak". All other sound outputs remain switched on.
- Switching off display: Switch off display.
 - Call home: Calls the phone number stored in the navigator (only displayed when a phone is connected).
 - Detour: Activates the detour function (only displayed if a route is active).
 - Skip: Skips the next way point (only displayed if route is provided with way points).

My Motorcycle

- Turn: Changes the number of data displayed.
- Touching a data field on the display opens a menu for selecting the data.

- The values available for selection are dependent on the optional extras installed.

 The Mediaplayer function is only available when using a Bluetooth device in accordance with the A2DP standard, e.g. a BMW Motorrad communication system. ◀

Mediaplayer

- Long actuation to left: Play previous title.
- Long actuation to right: Play next title.
- Turning increases or reduces volume of a BMW Motorrad communication system connected via Bluetooth.

Warning and status messages

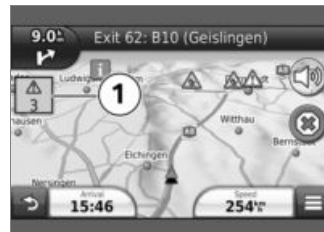

Warning and status displays of the motorcycle are indicated with a corresponding icon **1** at the upper left on the map view.

 If a BMW Motorrad communication system is connected, an acoustic signal is also sounds in case of a warning. ◀

If several warning messages are active, the number of messages is indicated below the warning triangle.

A list of all warning messages is opened by pressing on the

warning triangle with more than one message.

Additional information is displayed when a message is selected.

 Detailed information cannot be displayed for all warnings.◀

Special functions

Due to integration of the BMW Motorrad Navigator, there are a number of differences from the descriptions in the instruction manual for the Navigator.

Reserve fuel level warning

The settings for the fuel gauge are not available, as the reserve warning is being transferred from the vehicle to the Navigator. If the message is active, the nearest filling stations are displayed when the message is pressed.

Time and Date

The Navigator sends the time and date to the motorcycle. Transfer of this data into the instrument cluster must be activated in the **SETUP** menu of the instrument cluster.

Security settings

The BMW Motorrad Navigator V can be secured against unauthorized use with a four-digit PIN (Garmin Lock). If this function is activated, while the Navigator is cradled on the motorcycle and the ignition is switched on you are prompted to add the motorcycle to the list of secured vehicles. If you answer "Yes" to this question, the Navigator saves the vehicle identification number (VIN) of this motorcycle in its internal memory. A maximum of five VINs can be saved in this way.

When the Navigator is subsequently switched on by switching on the ignition on one of those motorcycles, entry of the PIN is no longer necessary.

If the Navigator is removed from the motorcycle while switched on, a security prompt asking for the PIN to be entered is issued.

Screen brightness

Screen brightness is adjusted by the motorcycle while the unit is cradled. No manual input is necessary.

The automatic setting can be switched off in the display settings in the Navigator if desired.

Case

– with case^{OA}

Opening case

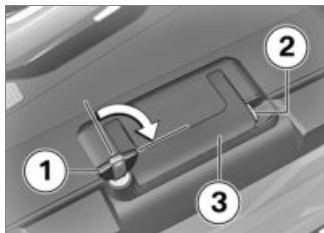

- Turn key **1** clockwise.
- Hold down yellow locking device **2** and fold out carrying handle **3**.



- Press yellow button **1** downward while opening case lid.

Closing case

- Turn key in case lock perpendicular to direction of travel.
- Close case lid.
- » The lid clicks audibly into place.

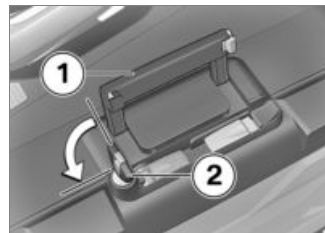

! If the carrying handle is folded down when the slot of the case lock is oriented in the direction of travel, the lock tab can be damaged. Before folding down the carrying handle, make sure that the slot of the case lock is perpendicular to the direction of travel.◀

- Fold carrying handle **1** down.
- Turn key **2** counterclockwise and remove.

Adjusting case volume

- Open and empty case.



- Engage pivot lever **1** in upper end position to obtain smaller volume.
- Engage pivot lever **1** in lower end position to set larger volume.
- Close case.

Removing case

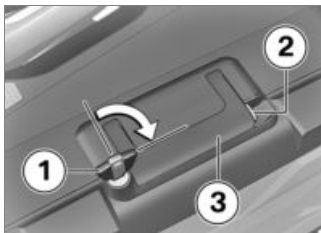

- Turn key **1** clockwise.
- Hold down yellow locking device **2** and fold out carrying handle **3**.



- Pull up red release lever **1**.

- » Locking flap **2** pops up.
- Fold locking flap all the way open.
- Remove case from mount by its handle.

Mounting case

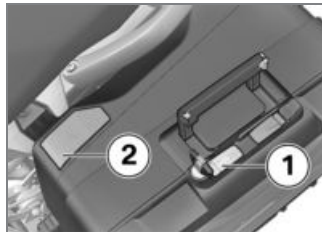

- Pull up red release lever **1**.
- » Locking flap **2** pops up.
- Fold locking flap all the way open.

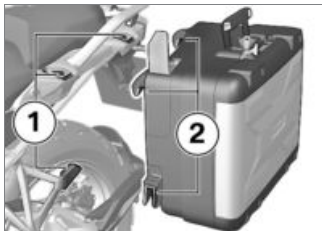

- Insert case from the top into mounts **1** and **2**.

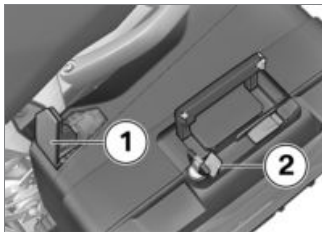

- Press locking flap **1** down until resistance can be felt.

- Next, press locking flap and red release lever **2** down at the same time.
- » Locking flap clicks into place.

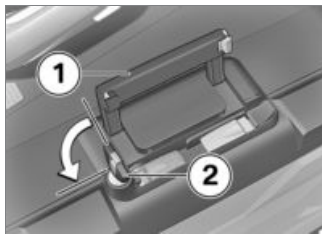

- ⚠** If the carrying handle is folded down when the slot of the case lock is oriented in the direction of travel, the lock tab can be damaged. Before folding down the carrying handle, make sure that the slot of the case lock is perpendicular to the direction of travel.◀

- Fold carrying handle **1** down.

- Turn key **2** counterclockwise and remove.

Topcase

– with topcase^{OA}

Opening topcase

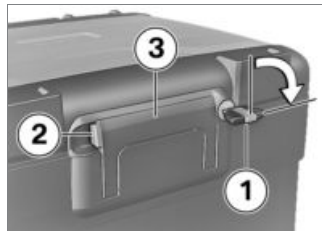

- Turn key **1** clockwise.
- Hold down yellow locking device **2** and fold out carrying handle **3**.

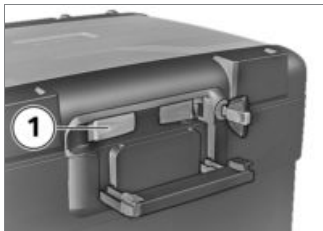

- Press yellow button **1** forward while opening the topcase lid.

Closing topcase

- Close topcase lid with firm pressure.

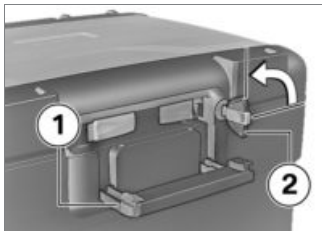

! If the carrying handle is folded down when the slot of the Topcase lock is horizontal, the lock tab can be damaged. Before folding down the carrying handle, make sure that the slot of the Topcase lock is vertical.◀

- Fold carrying handle **1** down.
» Carrying handle audibly engages.
- Turn key **2** counterclockwise and remove.

Adjusting topcase volume

- Open and empty topcase.



- Engage pivot lever **1** in front end position to set larger volume.
- Engage pivot lever **1** in rear end position to set smaller volume.
- Close topcase.

Removing topcase

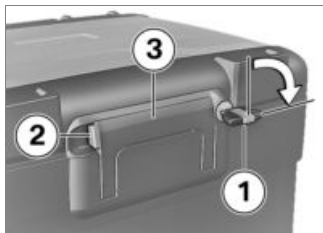

- Turn key **1** clockwise.
- Hold down yellow locking device **2** and fold out carrying handle **3**.

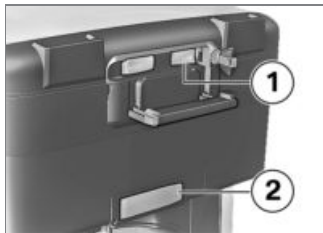

- Pull red lever **1** toward rear.

- » Locking flap **2** pops up.
- Fold locking flap all the way open.
- Remove topcase from mounting by its handle.

Mounting topcase

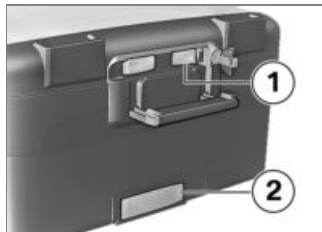

- Pull red lever **1** toward rear.
- » Locking flap **2** pops up.
- Fold locking flap all the way open.



- Hook topcase into front holders **1** of topcase retaining plate.
- Press topcase onto topcase retaining plate at rear.



- Press locking flap **1** forward until resistance can be felt.

- Next, press locking flap and red release lever **2** forward at the same time.
 - » Locking flap clicks into place.
- Turn key **2** counterclockwise and remove.

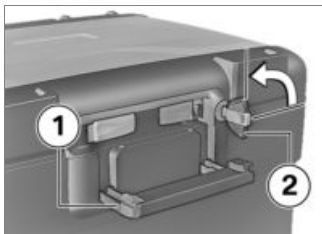

! If the carrying handle is folded down when the slot of the Topcase lock is horizontal, the lock tab can be damaged. Before folding down the carrying handle, make sure that the slot of the Topcase lock is vertical.◀

- Fold carrying handle **1** down.
 - » Carrying handle audibly engages.



Care

Care products	140
Washing your motorcycle	140
Cleaning sensitive motorcycle parts	141
Paint care	141
Storing the motorcycle.....	142
Protective wax coating	142
Returning motorcycle to use	142

Care products

BMW Motorrad recommends that you use cleaning and care products available at your authorized BMW Motorrad retailer. BMW CareProducts have been materials tested, laboratory tested, and field tested and provide optimum care and protection for the materials used in your vehicle.

 The use of unsuitable products for cleaning and care can damage motorcycle components.

For cleaning, do not use any solvents such as nitro-thinners, cold cleaning agents, fuel or similar, and do not use cleaning agents that contain alcohol.◀

Washing your motorcycle

BMW Motorrad recommends that you use BMW Insect Remover to soften and wash off insects and stubborn dirt from painted parts before washing the motorcycle.

To prevent stains, do not wash the motorcycle immediately after it has been exposed to bright sunlight and do not wash it in the sun.

Make sure that the motorcycle is washed frequently, especially during the winter months.

To remove road salt, clean the motorcycle with cold water immediately after completion of every trip.

 After washing the motorcycle, after driving through water or in the rain, braking can be delayed owing to damp brake rotors and brake pads.

Brake early until the brake rotors and brake pads are dry.◀

 Warm water intensifies the effect of salt.

Only use cold water to remove road salt.◀

 The high water pressure from high-pressure cleaners (steam blasters) can result in damage to seals, the hydraulic brake system, the electrics and the seat.

Do not use a steam jet or high-pressure cleaning equipment.◀

 Cases and topcases made of aluminum have no surface coating. The best possible appearance is preserved with the following care:

Remove road salt and corrosive deposits immediately with cold water after completing the trip.◀

Cleaning sensitive motorcycle parts

Plastics



If plastic parts are cleaned using unsuitable cleaning agents, the surfaces can be damaged.

Do not use cleaning agents that contain alcohol, solvents or abrasives to clean plastic parts.

'Insect sponges' or sponges with hard surfaces can also lead to scratches. ◀

Fairings and Panels

Clean fairings and panels with water and BMW plastic cleaner.

Windshields and lenses are manufactured of plastic

Clean off dirt and insects with a soft sponge and plenty of water.



Soften stubborn dirt and dead insects by covering

the affected areas with a wet cloth. ◀



Clean with water and sponge only.



Do not use chemical cleaning agents.

Chrome

Especially in the case of road salt, carefully clean chrome parts with plenty of water and BMW auto shampoo. Use chrome polish for additional treatment.

Radiator

Clean the radiator regularly to prevent overheating of the engine due to inadequate cooling. For example, use a garden hose with low water pressure.



Cooling fins can be bent easily.

When cleaning the radiator, ensure that the fins are not bent. ◀

Rubber parts

Treat rubber components with water or BMW rubber protection coating agent.



Using silicone sprays for the care of rubber seals can cause damage.

Do not use silicone sprays or care products that contain silicone. ◀

Paint care

Washing the vehicle on a regular basis will help prevent long-term damage from harmful substances, and is especially important when your vehicle is used in areas with high levels of air pollution or where natural contaminants such as tree resin and pollen are present.

However, remove particularly aggressive substances (spilled fuel, oil grease, brake fluid as well as bird droppings) immediately; otherwise changes in the paint or discolorations may occur. BMW Motorrad recommends BMW car polish or BMW paint cleaner for the purpose. Contamination on the paint finish is particularly easy to see after the vehicle has been washed. Remove this type of soiling with cleaning naphtha or spirit on a clean cloth or cotton ball. BMW Motorrad recommends using BMW tar remover for removing tar spots. Then add a protective wax coating to the paint at these locations.

Storing the motorcycle

- Completely fill the motorcycle's fuel tank.
- Clean motorcycle.

- Remove battery (➡ 122).
- Spray the brake and clutch lever, and the center and side stand pivots with a suitable lubricant.
- Coat bare metal and chrome-plated parts with an acid-free grease (Vaseline).
- Park motorcycle in a dry room, raising it to remove weight from both wheels (preferably using the front wheel and rear-wheel stand offered by BMW).

Protective wax coating

Paint must be protected, if water no longer pearls up on it. To preserve the finish of your vehicle, BMW Motorrad recommends BMW Car Wax or agents that contain carnauba or synthetic waxes.

Returning motorcycle to use

- Remove the protective wax coating.
- Clean the motorcycle.
- Install a charged battery.
- Observe checklist before starting.

Technical data

Troubleshooting chart	144
Threaded fasteners	145
Engine	147
Fuel.....	148
Engine oil	149
Clutch	149
Transmission	150
Rear-wheel drive.....	151
Suspension	151
Brakes	152
Wheels and tires	153
Electrical system.....	154
Anti-theft alarm system	155
Frame	155
Dimensions	156

Weights.....	157
Performance data	157

Threaded fasteners

Front wheel	Value	Valid
Brake caliper on telescopic forks		
M10 x 65	28 lb/ft (38 Nm)	
Clamping screw for quick-release axle in telescopic fork		
M8 x 35	14 lb/ft (19 Nm)	
Rear wheel	Value	Valid
Tighten rear wheel on wheel flange		
M10 x 1.25 x 40	Diagonally	
	44 lb/ft (60 Nm)	
Mirror arm	Value	Valid
Mirror (locknut) on adapter		
Left-hand thread, M10 x 1.25	16 lb/ft (22 Nm)	
Adapter on clamping block		
M10 x 14 - 4.8	18 lb/ft (25 Nm)	

Handlebars	Value	Valid
Clamping block (handlebar clamp) on fork bridge		
M8 x 35	Tighten on block in front (in the direction of travel) 14 lb/ft (19 Nm)	

Engine

Engine design	Air/liquid-cooled two-cylinder, four-stroke opposed-twin engine with two spur gear-driven overhead camshafts and one counterbalance shaft.
Displacement	1170 cc (1170 cm ³)
Cylinder bore	4 in (101 mm)
Piston stroke	2.9 in (73 mm)
Compression ratio	12.5:1
Rated output	125 hp (92 kW), at engine speed: 7750 min ⁻¹
Torque	92 lb/ft (125 Nm), at engine speed: 6500 min ⁻¹
Maximum engine speed	max 9000 min ⁻¹
Idle speed	1150 min ⁻¹ , engine at operating temperature

Fuel

Recommended fuel quality	Super unleaded (max. 10 % ethanol, E10) 89 AKI (95 ROZ/RON) 89 AKI
Alternative fuel quality	Regular unleaded (restrictions with regard to power and fuel consumption. If the engine should for example be operated with 91 RON in countries with lower fuel quality, the motorcycle must be respectively programmed first by your authorized BMW Motorrad retailer.) 87 AKI (91 ROZ/RON) 87 AKI
Usable fuel quantity	Approx. 5.3 gal (Approx. 20 l)
Reserve fuel quantity	Approx. 1.1 gal (Approx. 4 l)

BMW recommends BP fuel

Engine oil

Engine oil, capacity	max 1.1 gal (max 4 l), with filter replacement
Specification	SAE 5W-40, API SL / JASO MA2, additives (e.g. on a molybdenum basis) are not permitted, as they will attack coated engine components, BMW Motorrad recommends Castrol Power 1 Racing 4T SAE 5W-40, API SL/JASO MA2
Engine oil, quantity for topping up	max 1 quarts (max 0.95 l), difference between MIN and MAX

BMW recommends 

Clutch

Clutch design	Multi-disk wet clutch
---------------	-----------------------

Transmission

Transmission design	Helical-gear 6-speed transmission integrated in crankcase
Transmission gear ratios	1.000 (60:60 teeth), Primary gear ratio 1.650 (32:20 teeth), Transmission input ratio 2.438 (39:16 teeth), 1st gear 1.714 (36:21 teeth), 2nd gear 1.296 (35:27 teeth), 3rd gear 1.059 (36:34 teeth), 4th gear 0.943 (33:35 teeth), 5th gear 0.848 (28:33 teeth), 6th gear 1.061 (35:33 teeth), Transmission output ratio

Rear-wheel drive

Type of final drive	Shaft drive with bevel gears
Type of rear suspension	Cast-aluminum single swing arm with BMW Motorrad paralever
Gear ratio of final drive	2.91 (32:11 teeth)

Suspension

Front wheel

Type of front suspension	BMW Telelever, upper fork bridge tilt decoupled, leading link mounted in engine and on telescopic fork, centrally positioned spring strut supported on leading link and frame
Design of the front-wheel suspension	Central spring strut with coil spring
– with dynamic ESA ^{OE}	Central spring strut with coil spring and expansion tank, electrically adjustable rebound-stage and compression damping
Spring travel, front	7.5 in (190 mm), on wheel
– with lowering ^{OE}	6.3 in (160 mm), on wheel

Rear wheel

Type of rear suspension	Cast-aluminum single swing arm with BMW Motorrad paralever
Type of rear suspension	Central spring strut with coil spring, adjustable rebound-stage damping and spring preload
– with dynamic ESA ^{OE}	Central spring strut with coil spring and expansion tank, electrically adjustable rebound-stage and compression damping, electrically adjustable spring preload
Spring travel at rear wheel	7.9 in (200 mm)
– with lowering ^{OE}	6.7 in (170 mm)

Brakes

Type of front brake	Hydraulically operated double disc brakes with 4-piston radial monobloc calipers and floating brake discs
Brake-pad material, front	Sintered metal
Type of rear brake	Hydraulic disk brake with 2-piston floating caliper and fixed brake rotor
Brake-pad material, rear	Organic

Wheels and tires

Recommended tire combinations	You can obtain an overview of the current tire approvals from your authorized BMW Motorrad retailer or on the Internet at www.bmw-motorrad.com .
Front wheel	
Front wheel design	Aluminum cast wheel
– with cross-spoke wheels ^{OE}	Cross spoke wheel
Front-wheel rim size	3.0"x19"
Front tire designation	120/70 - 19
Rear wheel	
Rear wheel design	Aluminum cast wheel
– with cross-spoke wheels ^{OE}	Cross spoke wheel
Rear-wheel rim size	4.50"x17"
Rear tire designation	170/60 - 17
Tire inflation pressures	
Tire pressure, front	36.3 psi (2.5 bar), with tire cold
Tire pressure, rear	42.1 psi (2.9 bar), with tire cold

Electrical system

Electrical rating of onboard sockets	max 5 A, all onboard sockets together
Fuse carrier 1	10 A, Slot 1: instrument cluster, anti-theft alarm system (DWA), ignition lock, diagnostic socket 7.5 A, Slot 2: left multifunction switch, Tire Pressure Control (TCP/RDC)

Battery

Battery design	AGM (Absorptive Glass Mat) battery
Battery voltage	12 V
Battery capacity	12 Ah

Spark plugs

Spark plugs, manufacturer and designation	NGK LMAR8D-J
Electrode gap of spark plug	0.03±0.01 in (0.8±0.1 mm)

Bulbs

Bulb for high-beam headlight	H7 / 12 V / 55 W
– with LED headlights ^{OE}	LED
Bulbs for low-beam headlight	H7 / 12 V / 55 W
– with LED headlights ^{OE}	LED
Bulb for parking light	W5W / 12 V / 5 W

– with LED headlights ^{OE}	LED
Bulb for taillight/brake light	LED
Bulbs for flashing turn indicators, front	RY10W / 12 V / 10 W
Bulbs for flashing turn indicators, rear	RY10W / 12 V / 10 W

Anti-theft alarm system

Activation time	Approx. 30 s
Alarm duration	Approx. 26 s
Battery type	CR 123 A

Frame

Frame design	Steel-tube frame with partially self-supporting drive unit, steel-tube rear frame
Location of type plate	Frame at front right (next to spring strut)
Location of the vehicle identification number	Frame at front right on steering head

Dimensions

Motorcycle length	86.8 in (2205 mm), across splash guard
Motorcycle height	56.3...58.7 in (1430...1490 mm), across windshield, at DIN unladen weight
– with lowering ^{OE}	55.3...57.7 in (1405...1465 mm), above windshield, lower position, at DIN unladen weight
Motorcycle width	37.6 in (955 mm), with mirrors
Rider's seat height	33.5...34.3 in (850...870 mm), without rider at unladen weight
– with low rider's seat ^{OE}	32.3...33.1 in (820...840 mm), without rider at unladen weight
– with lowering ^{OE}	31.5...32.3 in (800...820 mm), without rider at unladen weight
Rider's inside-leg arc, heel to heel	73.6...75.2 in (1870...1910 mm), without rider at unladen weight
– with low rider's seat ^{OE}	71.7...73.2 in (1820...1860 mm), without rider at unladen weight
– with lowering ^{OE}	70.5...72 in (1790...1830 mm), without rider at unladen weight

Weights

Unladen weight	525 lbs (238 kg), DIN unladen weight, ready for road, fuel tank 90 % full, without OE
Permissible gross weight	992 lbs (450 kg)
Maximum payload	467 lbs (212 kg)

Performance data

Top speed	>124 mph (>200 km/h)
-----------	----------------------

Service

Reporting safety defects	160
BMW Motorrad Service	161
BMW Motorrad Mobility Services	161
Maintenance procedures	161
Confirmation of maintenance work	163
Confirmation of service	168

Reporting safety defects

If you believe that your vehicle has a defect which could cause a crash or could cause injury or death, you should immediately inform the National Highway Traffic Safety Administration (NHTSA) in addition to notifying BMW of North America, LLC.

If NHTSA receives similar complaints, it may open an investigation, and if it finds that a safety defect exists in a group of vehicles, it may order a recall and remedy campaign. However, NHTSA cannot become involved in individual problems between you, your retailer, or BMW of North America, LLC.

To contact NHTSA, you may call the Vehicle Safety Hotline toll-free at 1-888-327-4236 (TTY: 1-800-424-9153); go to <http://www.safercar.gov>; or write to: Administrator, NHTSA, 400 Seventh Street, SW., Washington, DC 20590. You can also obtain other information about motor vehicle safety from <http://www.safercar.gov>.

BMW Motorrad Service

With its worldwide dealer network, BMW Motorrad can attend to you and your motorcycle in over 100 countries around the globe. Authorized BMW Motorrad retailers have the technical information and expertise needed to conduct reliable service and repairs covering every aspect of your BMW.

You can find the nearest authorized BMW Motorrad retailer by visiting our Internet site at "www.bmw-motorrad.com".



If this maintenance and repair work is performed inexpertly, there is a danger of damage and associated safety risks. BMW Motorrad recommends having corresponding work on your motorcycle carried out by a specialized workshop, preferably

by an authorized BMW Motorrad retailer. ◀

To ensure that your BMW consistently remains in optimal condition BMW Motorrad urges you to observe the recommended service intervals.

Have all maintenance and repair work confirmed in the "Service" chapter in this manual. For generous treatment of claims submitted after the warranty period has expired (goodwill), evidence of regular maintenance is essential.

You can obtain information on the contents of the BMW Services from your BMW Motorrad retailer.

BMW Motorrad Mobility Services

The BMW Motorrad Mobility Services furnish you and your new BMW motorcycle with extra security by offering a wide array of assistance services in the event of a breakdown (BMW Roadside Assistance, breakdown assistance, vehicle recovery and retrieval, etc.).

Contact your authorized BMW Motorrad retailer for additional information on available mobility-maintenance services.

Maintenance procedures

BMW Pre-Delivery Check

The BMW pre-delivery check is carried out by your authorized BMW Motorrad retailer before it turns over the vehicle to you.

BMW Running-in Check

The BMW running-in check must be carried out between 300 mls (500 km) and 750 mls (1200 km).

BMW Service

BMW Service is carried out once a year. The scope of the services performed may be dependent on the vehicle owner and the mileage driven. Your BMW Motorrad retailer confirms that the service has been performed and enters the date for the next service.

For riders who drive long distances annually, it may be necessary to come in for service before the entered date. In this case a corresponding maximum odometer reading will also be entered in the confirmation of service. If this odometer reading is reached before the next service date, service must be performed sooner.

The service display in the multi-function display reminds you of the next service date approx. one month or 620 miles (1000 km) before the entered values.

Confirmation of maintenance work

BMW Pre-Delivery Check

Conducted

on _____

Stamp, Signature

BMW Running-in Check

Conducted

on _____

Odometer reading _____

Next service
at the latest

on _____

or, if reached sooner,

Odometer reading _____

Stamp, Signature

BMW Service

Conducted

on _____

Odometer reading _____

Next service
at the latest

on _____

or, if reached sooner,

Odometer reading _____

Stamp, Signature**BMW Service**

Conducted

on _____

Odometer reading _____

Next service
at the latest

on _____

or, if reached sooner,

Odometer reading _____

Stamp, Signature**BMW Service**

Conducted

on _____

Odometer reading _____

Next service
at the latest

on _____

or, if reached sooner,

Odometer reading _____

Stamp, Signature

BMW Service

Conducted

on _____

Odometer reading _____

Next service
at the latest

on _____

or, if reached sooner,

Odometer reading _____

Stamp, Signature**BMW Service**

Conducted

on _____

Odometer reading _____

Next service
at the latest

on _____

or, if reached sooner,

Odometer reading _____

Stamp, Signature**BMW Service**

Conducted

on _____

Odometer reading _____

Next service
at the latest

on _____

or, if reached sooner,

Odometer reading _____

Stamp, Signature

BMW Service

Conducted

on _____

Odometer reading _____

Next service
at the latest

on _____

or, if reached sooner,

Odometer reading _____

Stamp, Signature**BMW Service**

Conducted

on _____

Odometer reading _____

Next service
at the latest

on _____

or, if reached sooner,

Odometer reading _____

Stamp, Signature**BMW Service**

Conducted

on _____

Odometer reading _____

Next service
at the latest

on _____

or, if reached sooner,

Odometer reading _____

Stamp, Signature

BMW Service

Conducted

on _____

Odometer reading _____

Next service
at the latest

on _____

or, if reached sooner,

Odometer reading _____

Stamp, Signature**BMW Service**

Conducted

on _____

Odometer reading _____

Next service
at the latest

on _____

or, if reached sooner,

Odometer reading _____

Stamp, Signature**BMW Service**

Conducted

on _____

Odometer reading _____

Next service
at the latest

on _____

or, if reached sooner,

Odometer reading _____

Stamp, Signature

Confirmation of service

The table is intended as proof of maintenance and repair work, the installed optional accessories and any special campaign (recall) work carried out.

Work carried out	Odometer reading	Date

Work carried out	Odometer reading	Date

Appendix

Certificate..... 172

Certification Tire Pressure Control (TPC)

FCC ID: MRXBC54MA4
IC: 2546A-BC54MA4

FCC ID: MRXBC5A4
IC: 2546A-BC5A4

This device complies with Part 15 of the FCC Rules and with Industry Canada license-exempt RSS standard(s).

Operation is subject to the following two conditions:

- (1) This device may not cause harmful interference, and
- (2) This device must accept any interference received, including interference that may cause undesired operation.

Le présent appareil est conforme aux CNR d'Industrie Canada applicables aux appareils radio exempts de licence. L'exploitation est autorisée aux deux conditions suivantes:

- (1) l'appareil ne doit pas produire de brouillage, et
- (2) l'utilisateur de l'appareil doit accepter tout brouillage radioélectrique subi, même si le brouillage est susceptible d'en compromettre le fonctionnement.

WARNING: Changes or modifications not expressly approved by the party responsible for compliance could void the user's authority to operate the equipment. The term "IC:" before the radio certification number only signifies that Industry Canada technical specifications were met.

- A**
- Abbreviations and symbols, 6
- ABS
 - Control, 15
 - Operating, 56
 - Self-diagnosis, 80
 - Technology in detail, 91
 - Warning indicators, 33
- Accessories
 - General instructions, 126
- Air filter
 - Position in motorcycle, 13
 - Replacing insert, 118
- Ambient temperature
 - Outside temperature warning, 29
- Anti-theft alarm system
 - Operating, 50
 - Warning indicator, 31
- ASC
 - Control, 15
 - Operating, 57
 - Self-diagnosis, 80
 - Technology in detail, 94
- Average values
 - Resetting, 45
- B**
- Battery
 - Charging connected battery, 121
 - Charging disconnected battery, 121
 - Installing, 122
 - Maintenance instructions, 120
 - Removing, 122
 - Technical data, 154
 - Warning for battery charging voltage, 36
- Brake fluid
 - Checking fluid level at rear, 103
 - Checking front fluid level, 102
 - Front reservoir, 13
 - Rear reservoir, 13
- Brake pads
 - Checking front, 100
 - Checking rear, 101
 - Running in, 81

- Brakes
 - Adjusting handlebar lever, 68
 - Checking operation, 100
 - Safety instructions, 82
 - Technical data, 152
- Breaking in, 81
- Bulbs
 - Replace additional LED headlight, 117
 - Replacing bulb for high-beam headlight, 113
 - Replacing bulb for parking light, 115
 - Replacing bulb for turn indicator, 116
 - Replacing bulbs for low-beam headlight, 113
 - Replacing LED tail light, 117
 - Replacing the LED headlight, 117
 - Technical data, 154
 - Warning indicator for defective bulb, 30

C

- Case
 - Operating, 131
- Checklist, 78
- Clock
 - Adjusting, 47
- Clutch
 - Adjusting handlebar lever, 67
 - Checking operation, 105
 - Technical data, 149
- Confirmation of maintenance work, 163
- Coolant
 - Checking level, 104
 - Overheating warning indicator, 29
 - Topping up, 104
- Cruise control
 - Operating, 61

D

- Damping
 - Adjusting, 64
 - Rear adjuster, 11
- Dimensions
 - Technical data, 156

DWA

- Indicator lamp, 18
- Technical data, 155

E

- Electrical system
 - Technical data, 154
- Emergency on/off switch (kill switch), 17
 - Operating, 52
- Engine
 - Starting, 78
 - Technical data, 147
 - Warning for electronic engine management, 30
 - Warning for the engine management system, 35
- Engine oil
 - Checking level, 99
 - Fill location, 13
 - Fluid level indicator, 13
 - Oil level indicator, 38
 - Technical data, 149
 - Topping up, 100

Warning for engine oil level, 36

Equipment, 7

ESA

- Control, 15
- Operating, 65

F

- Frame
 - Technical data, 155
- Front wheel stand
 - Mounting, 112
- Fuel
 - Fill location, 11
 - Refueling, 85
 - Reserve quantity, 37
 - Technical data, 148
- Fuel reserve
 - Warning indicator, 35
- Fuses
 - Replacing, 124
 - Technical data, 154

H

- Handlebars
 - Adjusting, 69

Hazard warning flashers
Control, 15, 17
Operating, 55

Headlight
Adjusting for RHD/LHD
traffic, 53
Headlamp range, 53
Headlamp range
adjustment, 11

Headlight courtesy delay
feature, 43

Heated handlebar grips
Control, 17
Operating, 69

Horn, 15

I

Ignition
Switching off, 43
Switching on, 43

Immobilizer
Spare key, 43
Warning indicator, 29

Indicator lights, 18
Overview, 20

Instrument cluster
Ambient light sensor, 18
Overview, 18

J
Jump-start, 119

K
Keys, 42

L

Lights
Control, 15
Lowbeam headlamp, 54
Operating auxiliary
headlight, 54
Operating headlight flasher, 54
Operating high-beam
headlight, 54
Parking lamps, 54
Parking light, 54

Lowered suspension
Limitations, 76

Luggage
Loading information, 76

M

Maintenance
General instructions, 98
Maintenance intervals, 161

Mirrors
Adjusting, 70

Mobility Services, 161

Motorcycle
Care, 139
Cleaning, 139
Parking, 83
Returning to use, 142
Storage, 142
Tying down, 86

Multifunction display, 18
Control, 15
Operating, 44
Overview, 22
Selecting display readings, 44

Multifunction switch
General view, left , 15
General view, right, 17

N

Notice concerning current
status, 7

- O**
 - Odometer
 - Resetting, 45
 - Offroad riding, 83
 - Onboard power socket
 - Information on use, 126
 - Position on vehicle, 13
 - Onboard tool kit
 - Contents, 98
 - Position on vehicle, 14
 - Outside temperature
 - Display, 37
 - Overview of warning indicators, 25
 - Overviews
 - Instrument cluster, 18
 - Left side of vehicle, 11
 - Left-hand multifunction switch, 15
 - Multifunction display, 22
 - Right side of vehicle, 13
 - Right-hand multifunction switch, 17
 - Underneath seat, 14
 - Warning and indicator lamps, 20
 - Warning symbols, 23
- P**
 - Parking light, 54
 - Pre-Ride-Check, 79
- R**
 - RDC
 - Rim sticker, 107
 - Technology in detail, 95
 - Warning lamps, 31
 - Rear-wheel drive
 - Technical data, 151
 - Refueling, 85
 - Rider's Manual (US Model)
 - Position on vehicle, 14
 - Riding mode
 - Adjusting, 58
 - Control, 17
 - Technology in detail, 90
- S**
 - Safety instructions
 - On braking, 82
 - On riding, 76
 - Seat
 - Height adjustment position, 14
 - Seats
 - Adjusting seat height, 72
 - Locking mechanism, 11
 - Removing and installing, 71
 - Service, 161
 - Reporting safety defects, 160
 - Service display, 38
 - Shifting gears
 - Upshift recommendation, 39
 - Spark plugs
 - Technical data, 154
 - Speedometer, 18
 - Spring preload
 - Adjusting, 64
 - Rear adjuster, 13
 - Starting, 78
 - Control, 17
 - Steering lock
 - Locking, 42

Suspension
 Technical data, 151
Switching off, 83

T

Tachometer, 18
Technical data
 Anti-theft alarm system, 155
 Battery, 154
 Brakes, 152
 Bulbs, 154
 Clutch, 149
 Dimensions, 156
 Electrical system, 154
 Engine, 147
 Engine oil, 149
 Frame, 155
 Fuel, 148
 Rear-wheel drive, 151
 Spark plugs, 154
 Standards, 7
 Suspension, 151
 Transmission, 150
 Weights, 157
 Wheels and tires, 153

Tire Pressure Control TPC/RDC
 Display, 39
Tires
 Checking tire inflation pressures, 68
 Checking tire tread depth, 106
 Inflation pressure table, 14
 Inflation pressures, 153
 Recommendation, 106
 Running in, 81
 Technical data, 153
 Top speed, 77
Topcase
 Operating, 134
Torques, 145
Transmission
 Technical data, 150
Troubleshooting chart, 144
Turn indicators
 Control, 15
 Control, right, 17
 Operating, 55
Type plate
 Position on vehicle, 13

V

Vehicle identification number
 Position on vehicle, 13

W

Warning lamps, 18
 ABS, 33
 Anti-theft alarm system, 31
 Battery charging voltage, 36
 Bulb defect, 30
 Coolant temperature, 29
 Display, 24
 Electronic engine management, 30
 Engine management system, 35
 Engine oil level, 36
 Fuel reserve, 35
 Immobilizer, 29
 Outside temperature warning, 29
 Overview, 20, 23
 Tire Pressure Monitor, 31

Weights

Payload table, 14

Technical data, 157

Wheels

Check wheel rims, 106

Checking spokes, 106

Install rear wheel, 111

Installing front wheel, 109

Removing front wheel, 107

Size change, 107

Technical data, 153

Windshield

Adjusting, 71

Adjustment element, 13

The descriptions and illustrations in this manual may vary from your own motorcycle's actual equipment, depending upon its equipment level and accessories as well as your specific national version. No claims stemming from these differences can be recognized.

Dimensions, weights, fuel consumption and performance data are quoted to the customary tolerances.

The right to modify designs, equipment and accessories is reserved.

Errors and omissions excepted.

© 2014 Bayerische Motoren
Werke Aktiengesellschaft
80788 Munich, Germany

Reprints and duplication of this work, in whole or part, are prohibited without the express written approval of BMW Motorrad, Aftersales.

Original Rider's Manual, printed in Germany.

Important data for refueling:

Fuel	
Recommended fuel quality	Super unleaded (max. 10 % ethanol, E10) 89 AKI (95 ROZ/RON) 89 AKI
Alternative fuel quality	Regular unleaded (restrictions with regard to power and fuel consumption. If the engine should for example be operated with 91 RON in countries with lower fuel quality, the motorcycle must be respectively programmed first by your authorized BMW Motorrad retailer.) 87 AKI (91 ROZ/RON) 87 AKI
Usable fuel quantity	Approx. 5.3 gal (Approx. 20 l)
Reserve fuel quantity	Approx. 1.1 gal (Approx. 4 l)
Tire inflation pressures	
Tire pressure, front	36.3 psi (2.5 bar), with tire cold
Tire pressure, rear	42.1 psi (2.9 bar), with tire cold

BMW recommends 

Order No.: 01 41 8 554 637

04.2014, 5th edition, 07

