

Maintenance Instructions

R 1150 GS

R 1150 GS Adventure



**BMW Motorrad
On-board
documentation**

consisting of
Rider's Manual
and Maintenance
Instructions



Please note



Warning:

This symbol stands for precautions and measures which are essential in order to protect the rider or other persons from possibly severe or fatal injury.



Caution:

Specific instructions and safety precautions intended to prevent damage to the motorcycle. Disregarding them may render the warranty invalid.



Note:

Specific instructions on how to operate, control, adjust or look after items of equipment on the motorcycle.

For safety reasons and to maintain the value of your motorcycle, regular maintenance intervals have been laid down. Always keep to the specified maintenance intervals. This is the only way to ensure that warranty claims are not invalidated. The contents of the maintenance charts are subject to change, for reasons of safety, due to modifications in, among other things, materials. Your authorised BMW motorcycle dealer can provide information on the currently specified Service, Inspection and Annual Service work needed.

Important:

BMW refuses to accept liability for damage or consequential damage due to repairs or service work carried out by other than BMW-authorised workshops.

Consequently, we recommend that you have service work carried out by the specially trained experts at your authorised BMW motorcycle dealer, and have this confirmed in the Maintenance Instructions.

Authorised BMW motorcycle dealers are supplied with the latest technical information and have the necessary technical know-how and specially trained staff.

Please do not hesitate to contact your authorised BMW motorcycle dealer on all matters concerning your motorcycle.

Authorised BMW motorcycle dealers are fully informed about all aspects of your motorcycle and will gladly advise and assist you.

Best wishes,

BMW Motorrad

Important safety information

1

2

BMW Service

For your own safety, use only genuine BMW spare parts and accessories approved by BMW.

If you choose genuine BMW accessories and spare parts that have been tested and approved, you can be sure that BMW has carried out the appropriate tests to confirm their suitability for use on your motorcycle. BMW accepts product liability only for these products.

Note, however, that BMW is unable to accept liability for spare parts and accessories which it has not approved.

BMW cannot assess every single product of outside origin in order to decide whether it can be used on or with a BMW vehicle without constituting a safety hazard.

Nor is approval by an official technical inspection authority, or even the granting of a general operating permit necessarily a sufficient guarantee, since these test procedures are not always adequate.

Genuine BMW spare parts, accessories and other products which BMW has approved can be obtained from all authorised BMW motorcycle dealers, together with expert advice on their installation and use.

Maintenance work is divided up into Service, Inspection and Annual Service.

BMW Inspection

1,000 km/600 miles

BMW Running-in Check after the first 1,000 km (600 miles).

BMW Service

After the first 10,000 km (6,000 miles) and subsequently every 20,000 km (12,000 miles) (18,000 miles, 30,000 miles, 42,000 miles...)

BMW Inspection

After the first 20,000 km (12,000 miles) and subsequently every 20,000 km (12,000 miles) (24,000 miles, 36,000 miles, 48,000 miles...)

BMW Annual Service

Certain items of maintenance work depend on elapsed time as well as the distance the motorcycle has covered. They should therefore be carried out at least once a year (e.g. changing the brake fluid).

If these items cannot be carried out during a Service or an Inspection, an Annual Service must be performed.



Note:

Every BMW motorcycle dealer has a fixed scale of charges based on work times and carefully calculated hourly rates. Lubricants and consumables, filters, gaskets etc. are billed separately.

Maintenance schedule

1

4

BMW Service

	BMW Inspection 1,000 km (600 miles)	BMW Service	BMW Inspection	BMW Annual Service
Read the fault code memory with the BMW diagnosis system	X	X	X	X
(BMW Integral ABS) Perform bleed test with BMW diagnosis system	X	X	X	
Change the engine oil while at regular operating temperature and replace the oil filter 1) *)	X	X	X	X
Change the oil in the gearbox while at regular operating temperature 2) *)			X	X
Change the oil in the rear wheel drive while at regular operating temperature 3) *)	X		X	X
Renew the fuel filter 4) *)			X	
Renew the intake air filter element 5) *)		X	X	
Check brake fluid level at front and rear		X	X	
Check operation of brake system and freedom from leaks; repair/replace items if necessary *)			X	
Examine brake pads and discs for wear, replace if necessary *)		X	X	
(Without BMW Integral ABS) Change brake fluid every twelve months				X
(BMW Integral ABS) Change brake fluid in wheel circuit every 12 months				X
(BMW Integral ABS) Change brake fluid in control circuit 2) *)				X

Maintenance schedule

	BMW Inspection 1,000 km (600 miles)	BMW Service	BMW Inspection	BMW Annual Service
(BMW Integral ABS) Perform bleed test with BMW diagnosis system				X
Check clutch fluid level		X	X	
Change clutch fluid 2) *)				X
Check tightness of rear wheel studs	X			
Check rear wheel bearing play			X	
Check swinging arm bearings (freedom from play), adjust if necessary *)	X		X	
Check operation of side stand switch	X	X	X	X
Grease the side stand pivot	X	X	X	
Retention poly-V-belt 6)		X		
Replace Poly-V belt 7) *)			X	
Check condition of spark plugs		X	X	
Renew spark plugs 8)			X	
Retorque cylinder heads	X			
Check valve clearances, adjust if necessary	X	X	X	
Check that the throttle cable moves freely and is free of kinks and chaffing, replace if necessary *)	X	X	X	
Check Bowden cable play	X	X	X	
Check synchronisation, adjust if necessary	X	X	X	

Maintenance schedule

1

6

BMW Service

	BMW Inspection 1,000 km (600 miles)	BMW Service	BMW Inspection	BMW Annual Service
<p>Final inspection with road safety and functional check:</p> <ul style="list-style-type: none"> - Condition of tyres and wheels - Tyre pressure - Lights and signals - Telltale and warning lights - Instruments - Clutch, gear shift - Handbrake, foot brake, steering - Optional extras, as fitted - Test ride 	X	X	X	X
<p>1) If the motorcycle is ridden for short distances only or at outside temperatures below 0 °C: every 3 months or after every 3,000 km (1,800 miles) at the latest</p> <p>2) Every 2 years</p> <p>3) Every 40,000 km (24,000 miles) or at the latest every 2 years</p> <p>4) Normally every 40,000 km (24,000 miles), if fuel is of poor quality every 20,000 km (12,000 miles)</p> <p>5) In very dusty or dirty conditions, replace the intake air filter element every 10,000 km (6,000 miles) or even more frequently</p> <p>6) Re-adjust new poly-V-belt one time at 10,000 km/6,000 miles</p> <p>7) Replace the Poly-V belt every 60,000 km (36,000 miles); do not adjust it</p> <p>8) Every 40,000 km (24,000 miles)</p> <p>*) Charged as an additional item</p>				

Confirmation of maintenance work

BMW Pre-delivery check

Carried out in accordance with manufacturer's instructions

Odometer reading _____

Date, stamp, signature

BMW Service 10,000 km (6,000 miles)

Carried out in accordance with manufacturer's instructions

Odometer reading _____

Date, stamp, signature

BMW Inspection 1,000 km (600 miles)

Carried out in accordance with manufacturer's instructions

Odometer reading _____

Date, stamp, signature

BMW Inspection 20,000 km (12,000 miles)

Carried out in accordance with manufacturer's instructions

Odometer reading _____

Date, stamp, signature

1

7

BMW Service

Confirmation of maintenance work

1

8

BMW Service

BMW Service 30,000 km (18,000 miles)

Carried out in accordance with
manufacturer's instructions

Odometer reading _____

Date, stamp, signature

BMW Service 50,000 km (30,000 miles)

Carried out in accordance with
manufacturer's instructions

Odometer reading _____

Date, stamp, signature

BMW Inspection 40,000 km (24,000 miles)

Carried out in accordance with
manufacturer's instructions

Odometer reading _____

Date, stamp, signature

BMW Inspection 60,000 km (36,000 miles)

Carried out in accordance with
manufacturer's instructions

Odometer reading _____

Date, stamp, signature

Confirmation of maintenance work

BMW Service 70,000 km (42,000 miles)

Carried out in accordance with
manufacturer's instructions

Odometer reading _____

Date, stamp, signature

BMW Service 90,000 km (54,000 miles)

Carried out in accordance with
manufacturer's instructions

Odometer reading _____

Date, stamp, signature

BMW Inspection 80,000 km (48,000 miles)

Carried out in accordance with
manufacturer's instructions

Odometer reading _____

Date, stamp, signature

BMW Inspection 100,000 km (60,000 miles)

Carried out in accordance with
manufacturer's instructions

Odometer reading _____

Date, stamp, signature

Confirmation of maintenance work

1

10

BMW Service

BMW Service 110,000 km (66,000 miles)

Carried out in accordance with
manufacturer's instructions

Odometre reading _____

Date, stamp, signature

BMW Service 130,000 km (78,000 miles)

Carried out in accordance with
manufacturer's instructions

Odometre reading _____

Date, stamp, signature

BMW Inspection 120,000 km (72,000 miles)

Carried out in accordance with
manufacturer's instructions

Odometre reading _____

Date, stamp, signature

BMW Inspection 140,000 km (84,000 miles)

Carried out in accordance with
manufacturer's instructions

Odometre reading _____

Date, stamp, signature

Confirmation of maintenance work

BMW Annual Service

Carried out in accordance with
manufacturer's instructions

Brake fluid changed:

Yes No

Clutch fluid changed:

Yes No

Date, stamp, signature

BMW Annual Service

Carried out in accordance with
manufacturer's instructions

Brake fluid changed:

Yes No

Clutch fluid changed:

Yes No

Date, stamp, signature

BMW Annual Service

Carried out in accordance with
manufacturer's instructions

Brake fluid changed:

Yes No

Clutch fluid changed:

Yes No

Date, stamp, signature

BMW Annual Service

Carried out in accordance with
manufacturer's instructions

Brake fluid changed:

Yes No

Clutch fluid changed:

Yes No

Date, stamp, signature

Confirmation of maintenance work

1

12

BMW Service

BMW Annual Service

Carried out in accordance with manufacturer's instructions

Brake fluid changed:
Yes No

Clutch fluid changed:
Yes No

Date, stamp, signature

BMW Annual Service

Carried out in accordance with manufacturer's instructions

Brake fluid changed:
Yes No

Clutch fluid changed:
Yes No

Date, stamp, signature

BMW Annual Service

Carried out in accordance with manufacturer's instructions

Brake fluid changed:
Yes No

Clutch fluid changed:
Yes No

Date, stamp, signature

BMW Annual Service

Carried out in accordance with manufacturer's instructions

Brake fluid changed:
Yes No

Clutch fluid changed:
Yes No

Date, stamp, signature

Confirmations of service work

Odometer replaced

Distance reading,
not total distance covered!

odometer reading _____

Date, stamp, signature

Odometer replaced

Distance reading,
not total distance covered!

odometer reading _____

Date, stamp, signature

Odometer replaced

Distance reading,
not total distance covered!

odometer reading _____

Date, stamp, signature

Odometer replaced

Distance reading,
not total distance covered!

odometer reading _____

Date, stamp, signature

Your motorcycle is equipped with Digital Motor Electronic (MOTRONIC) engine management, and a high-power ignition system.



Warning:

When the engine is running or the ignition is switched on, do not touch any electrically live components, terminals or wiring.

– Risk of fatal accident!

Work on the electrical system only when the circuit has been interrupted (switch off ignition and light). For greater safety, disconnect and insulate the negative battery lead.

If you intend to perform the maintenance and general care work described in the following section yourself, you must possess the necessary knowledge of technical matters and mechanical skills.

Your motorcycle is built to high technological standards.

Special tools and purpose-designed diagnosis and testing equipment, together with the appropriate knowledge, are needed to keep your motorcycle in optimum working order.

Your authorised BMW motorcycle dealer possesses the necessary technical know-how and employs company-trained staff. They can guarantee that your motorcycle is always maintained in a fault-free technical condition.

Remember: the safety and reliability of your motorcycle are the most important considerations.

You should therefore not attempt any complex repair or maintenance tasks.

Keep to the specified Inspection and Service intervals.

BMW refuses to accept liability for damage or consequential damage due to repairs or service work carried out by workshops other than BMW- authorised workshops.

Technical modifications



Warning:

The data stored in the MOTRONIC control unit is the result of extensive experimental and testing work. Tampering with the MOTRONIC control unit represents an increased safety risk for the rider.



Note:

Tampering with the MOTRONIC control unit invalidates the warranty.

Technical modifications are permitted only to a limited extent.

Whenever you are planning such modifications, comply with all the legal requirements. The motorcycle must not infringe your national road-vehicle construction and use regulations.

Your authorised BMW motorcycle dealer will gladly advise you on technical requirements, the manufacturer's recommendations and the overall benefit likely to be obtained.

Genuine BMW parts

For reasons of safety, use only genuine BMW parts and accessories.

Genuine BMW parts are identical with those fitted to your motorcycle as original equipment.

BMW Motorrad refuses to accept any liability whatsoever for other-make spare parts and accessories.

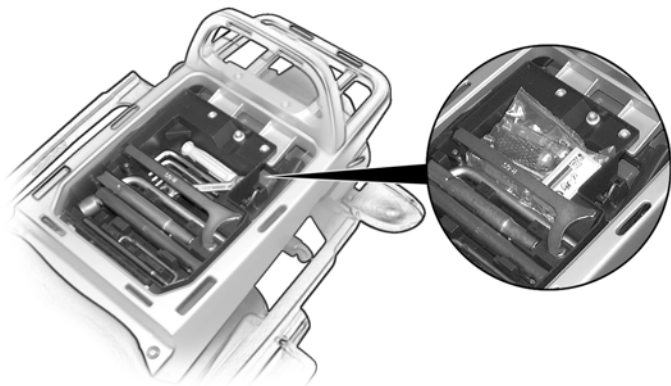

Tubeless tyre repair kit

For repair procedure, please refer to the accompanying instructions



Warning:

Only repair tyre damage up to 4 mm (0.16 in) in diameter.

Max. permitted speed: 60 km/h (app. 37 mile/h).

Max. permitted distance: 400 km (app. 250 miles).

Always have the damaged tyre replaced.

Contents

- 1 screwdriver, large, reversible blade
- 1 double open-ended spanner w/f* 10 x 13 mm
- 1 spark plug wrench
- 1 puller for spark plug caps
- 5 angled hex screwdrivers w/f* 3 mm, 4 mm, 5 mm, w/f* 6 mm, 8 mm
- 2 Torx T25, T30
- 1 wheel stud wrench
- 1 hook wrench for suspension strut
- 1 extension
- 1 tubular extension
- 1 locking element for toolbox
- 1 foam-rubber pad

• Toolkit under seat

*w/f = width across flats

Troubleshooting chart

Malfunction: Engine does not start at all or is very difficult to start

Possible cause	Remedy	See ➡ Page
Wrong ignition key position	Operate correctly	➡ Rider's Manual
Kill switch on	Operate correctly	➡ Rider's Manual
Side stand extended, gear selected	Operate correctly	➡ Rider's Manual
Power supply interrupted	Blown fuse	➡ 49
Gear engaged (clutch lever not pulled in)	Select neutral (or pull clutch lever)	➡ Rider's Manual
No fuel in fuel tank	Add fuel	➡ Rider's Manual
Fuel pump not working	Fuse 5 and/or 6 blown	➡ 49
Wrong twistgrip/choke setting	Operate correctly	➡ Rider's Manual
Blocked air filter element	Replace	
Defective spark plug	Replace	
Spark plug/leads or caps wet	Blow out/dry with compressed air	
Insufficient battery charge	Recharge battery	➡ 55

**Note:**

For more serious faults – and those not detailed on pages 16...66 – take your motorcycle to a specialist workshop, preferably an authorised BMW motorcycle dealer.

**Note:**

More detailed technical information is available in the following publications:

- BMW Repair Manual
- BMW electrical circuit-diagrams brochure

Removing the front wheel

2

22

Maintenance and care

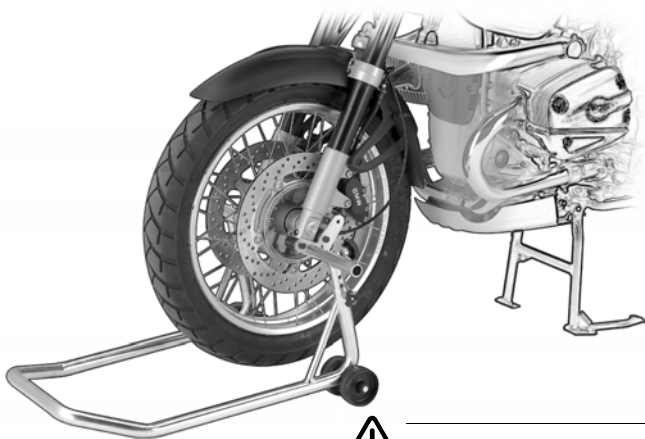

- Place the motorcycle on its centre stand,
 - after making sure that the ground is level and firm
- Raise the front wheel with front wheel stand, BMW special tool No. 36 3 970, or a suitable auxiliary stand, and support it if necessary



Note:

Make sure that the auxiliary stand is set to the correct width and height.



Caution:

When removing, avoid damage to brake pipes, brake discs, brake pads or the wheel rim (mask off with tape if necessary).

Do not scratch the rim when forcing back the brake pads or removing the calipers (mask off with tape if necessary).

To prevent damage to the brake caliper and possible difficulty when assembling: never apply the brake lever when the brake calipers have been removed.

Motorcycle with BMW Integral ABS^{OE}:

Do not damage the ABS sensor cable, ABS sensor ring or ABS sensor.

^{OE} Optional extra

Removing the front wheel

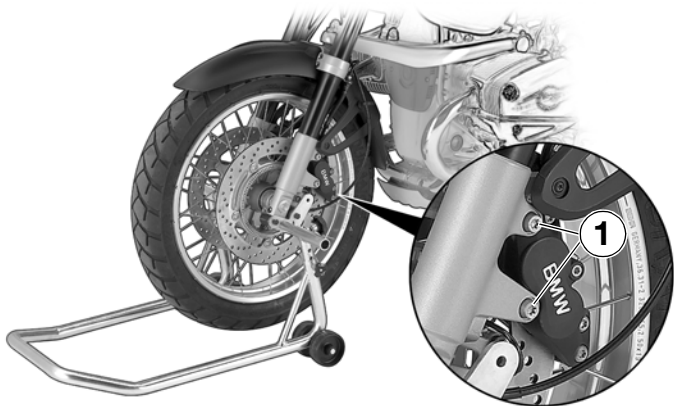

Warning:

Make sure that the motorcycle is standing firmly and cannot topple forwards or to either side.

- Remove securing screws **1** for the left and right brake calipers
- Push the brake pads back a little by lightly rocking the brake calipers
- Carefully take off the left and right brake calipers



Note:

Check the brake pads (➡ 34) (have them replaced if necessary).

Removing the front wheel

2
24

Maintenance and care

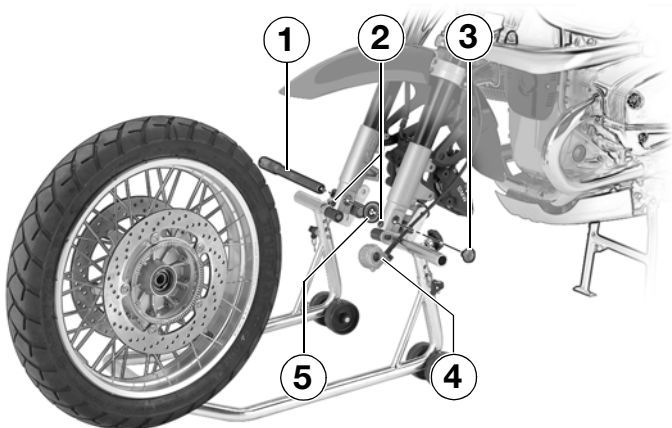

- Remove quick-release axle **1**
- Remove speedometer drive **4** and spacer bush **5**
- Roll the front wheel forwards and out



Note:

Mark the installed position on the tyre or ABS toothed ring^{OE} or note the direction-of-rotation arrow if it is marked on the tyre.

- Remove axle screw **3**
- Slacken axle clamp screws **2** on the left and right



Caution:

When setting down the front wheel, avoid damage to the brake discs and ABS sensor ring^{OE}. Keep dirt and moisture away from the wheel bearings.

^{OE} Optional extra

Installing the front wheel

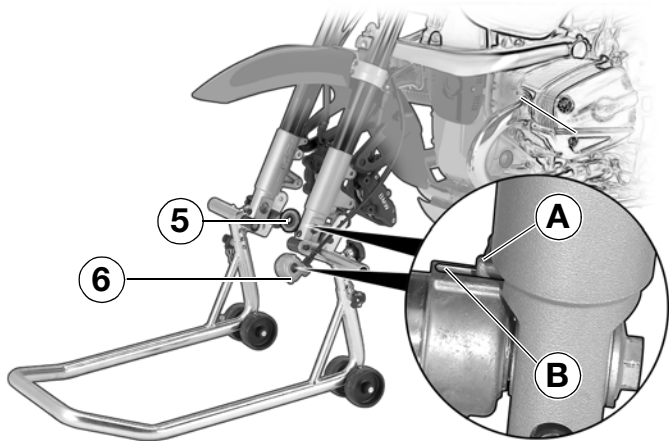

- Roll the front wheel in between the fork legs



Caution:

Avoid damage to brake lines, discs and pads when installing. Keep dirt and moisture away from the wheel bearings. Motorcycle with BMW Integral ABS^{OE}:

Do not damage the ABS sensor cable, the ABS sensor ring and the ABS sensor.



Note:

Note arrow on tyre indicating correct direction of rotation.



Caution:

To avoid damaging the speedometer drive, make sure that lug **A** on the sliding tube engages recess **B** in the speedometer drive.

- Insert the spacer bush and the speedometer drive
As viewed in forward direction of travel
 - left: speedometer drive **6**
 - right: spacer bush **5**

Installing the front wheel

2

26

Maintenance and care

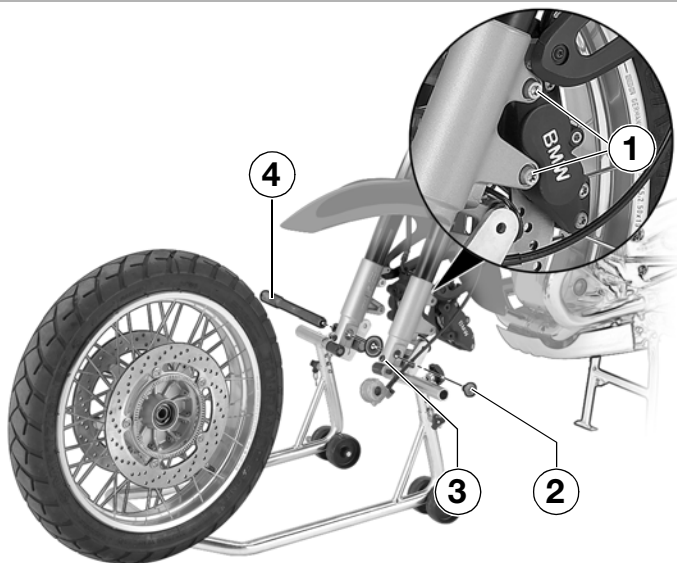

- Clean the quick-release axle, **4**, grease it, and insert it from the right, turning it slightly at the same time (while lifting the wheel)
- Hand-tighten axle screw **2**
- Hand-tighten axle clamp screws **3** on left and right
- Compress the front fork firmly several times
- Tighten axle screw **2** to specified torque
- Tighten axle clamp screws **3** at left and right to specified torque



Warning:

Make sure that the motorcycle is standing firmly and cannot topple forwards or to either side.

- Carefully push brake calipers **2** over the brake discs at left and right
- Install the brake calipers and tighten screws **1** to the specified torque



Caution:

Always have the tightening torques checked by a specialist workshop, preferably an authorised BMW motorcycle dealer.



Tightening torque:

Brake caliper screws	30 Nm
Axle screw	30 Nm
Axle clamp screws	22 Nm



Warning:

Motorcycle not equipped with BMW Integral ABS: when assembly work has been completed, pull the brake lever firmly several times to check that the front brake is operating correctly.

BMW Integral ABS^{OE}: once assembly work on the brake calipers has been completed, the brake lever has to be operated after the ignition has been switched on and self-diagnosis completed, in order to ensure full operability.

^{OE} Optional extra

Removing the rear wheel

2

28

Maintenance and care

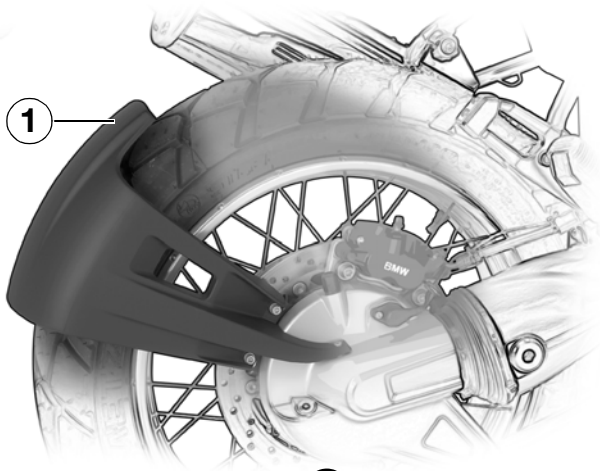

Warning:

Screws of rear-wheel cover 1 are secured with Loctite. Prior to reinstallation, clean the screw threads and recoat with Loctite 243.

- Place the motorcycle on its main stand
 - after making sure that the ground is level and firm

OE Optional extra



Warning:

Make sure that the motorcycle is standing firmly and cannot topple forwards or to either side.



Caution:

Avoid damage to brake lines, brake disc, brake pads, rims and spokes when removing.

Motorcycle with BMW Integral ABS^{OE}

Do not damage the ABS sensor cable, the ABS sensor ring and the ABS sensor.

Removing the rear wheel

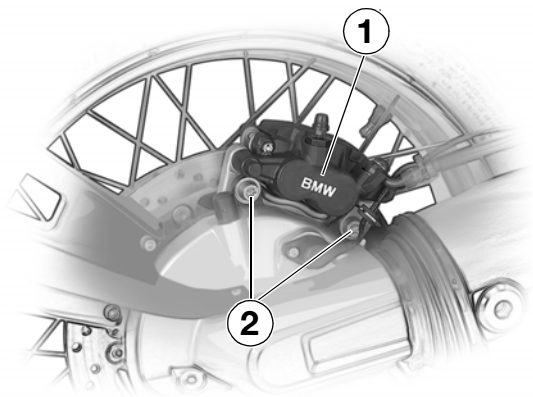

Caution:

Do not scratch the wheel when forcing back the brake pads or removing the caliper (apply masking tape if necessary).

To prevent damage to the brake caliper and possible difficulty when assembling: never operate the brake lever when the brake calipers have been removed.

- Remove screws **2** securing brake caliper **1**
- Force back the brake pads by tilting the caliper carefully
- Carefully take off the brake caliper



Note:

Check the brake pads (→ 35), have them replaced if necessary.

- Make sure that load is applied to the front wheel
- Select first gear

Removing the rear wheel

2

30

Maintenance and care

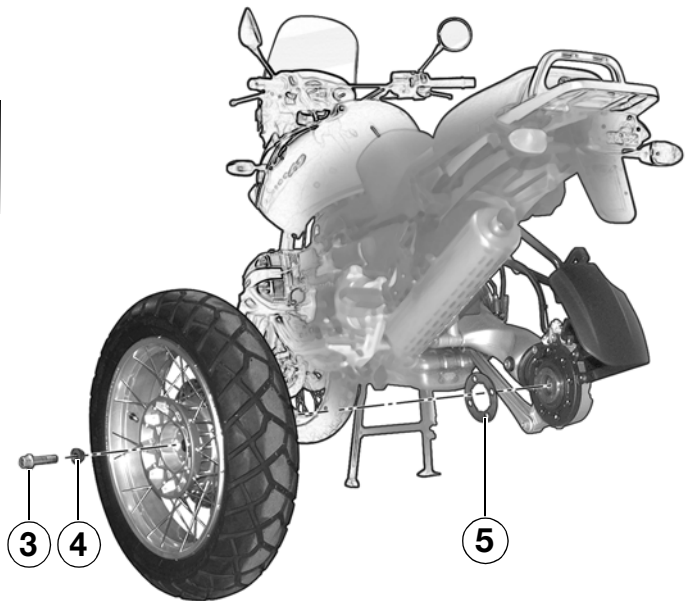

- Using the wheel stud socket spanner and extension, remove the four wheel studs **3** with taper rings **4**
 - Lift the rear wheel clear of its centering spigot, tilt it, lower it to the ground and remove it
- Motorcycle with BMW Integral ABS^{OE}: remove spacing washer **5** from wheel centering spigot



Caution:

Protect the wheel hub contact face against dust and dirt.

^{OE} Optional extra

Installing the rear wheel

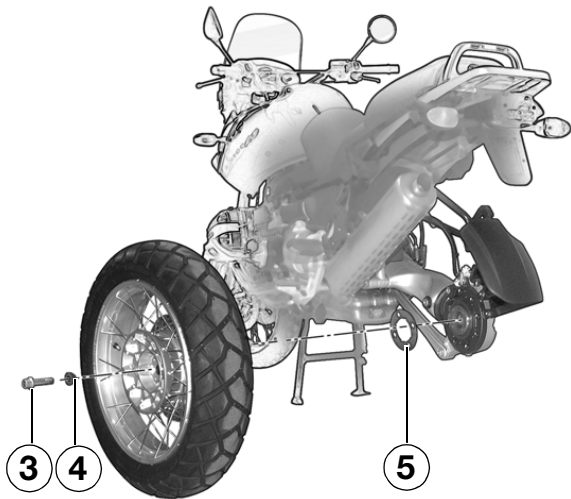

Caution:

Use only wheel studs with the same length code number. Do not oil or grease the wheel studs.

Avoid damage to brake lines, brake disc, brake pads, rims and spokes when installing. Motorcycle with BMW Integral ABS^{OE}:

Take care not to damage ABS sensor cable, ABS sensor ring, and ABS sensor.

- Check that the wheel centering spigot and the contact faces on the wheel hub and spacing washer are free from grease
- Motorcycle with BMW Integral ABS^{OE}: Fit spacing washer **5** on wheel centering spigot
- Insert rear wheel into centering hole
- Hand-tighten four wheel studs **3** with taper rings **4**, then tighten to the specified preload torque in diagonally opposite sequence
- Tighten the wheel studs **3** to the specified final torque in diagonally opposite sequence

^{OE} Optional extra

Installing the rear wheel

2

32

Maintenance and care

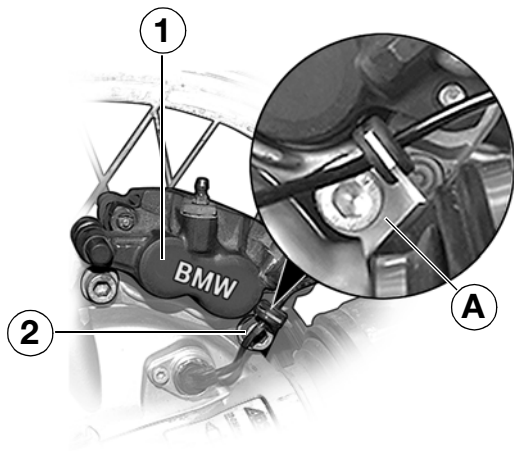

- Carefully place brake caliper **1** over the brake disc



Caution:

Make sure that retaining angle **A** is in the correct position.

- Install rear brake caliper screw **2** with washer
- Install front brake-caliper screw **2** with retaining angle **A**
- Tighten brake-caliper screws **2** to specified torque



Tightening torque:

Preload torque	
Wheel studs	72 Nm
Tightening torque	
Wheel studs	105 Nm
Brake caliper screws	40 Nm



Caution:

Always have the tightening torques checked by a specialist workshop, preferably an authorised BMW motorcycle dealer.



Warning:

Motorcycle not equipped with BMW Integral ABS: when assembly work has been completed, depress the brake pedal firmly several times to check that the rear brake is operating correctly.

BMW Integral ABS^{OE}: once assembly work on the brake calipers has been completed, the brake lever has to be operated after the ignition has been switched on and self-diagnosis completed, in order to ensure full operability.

^{OE} Optional extra

Checking brake pads

2

34

Maintenance and care

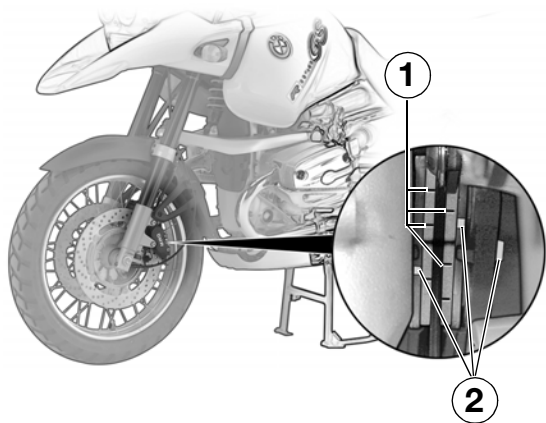

Front brake



Caution:

Have the brake pads replaced before the minimum permitted thickness is reached.



Note:

For your safety, we recommend having work on the brake system performed by a specialist workshop, preferably an authorised BMW motorcycle dealer.

- Place the motorcycle on its centre stand, after making sure that the ground is level and firm
- Visually inspect both brake pads and the brake caliper and make sure that they all bear the same colour mark **2**
- Visually check brake pad thickness

Minimum pad thickness:

Wear indicating mark 1 must be clearly visible on the pads.

– If the wear indicating mark is no longer clearly visible:

Have the brake pads changed by a specialist workshop, preferably an authorised BMW motorcycle dealer.

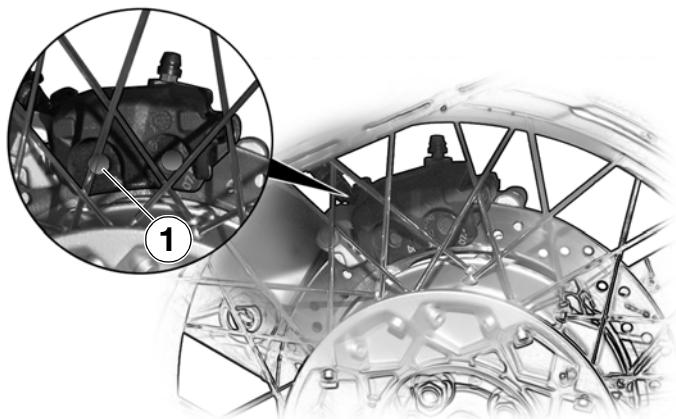

Rear brake



Caution:

Have brake pads replaced before the minimum permitted thickness is reached.



Note:

For your safety, we recommend having work on the brake system performed by a specialist workshop, preferably an authorised BMW motorcycle dealer.

- Make sure the ground is level and firm and lift the motorcycle onto its centre stand
- Visually check brake pad thickness
 - **Minimum pad thickness:** Make sure that the brake disc is not visible through the bore **1** in the inner brake pad
 - If the brake disc is visible through the bore **1** in the inner brake pad:
Have the brake pads changed by a specialist workshop, preferably an authorised BMW dealer

Headlight beam setting

2

36

Maintenance and care

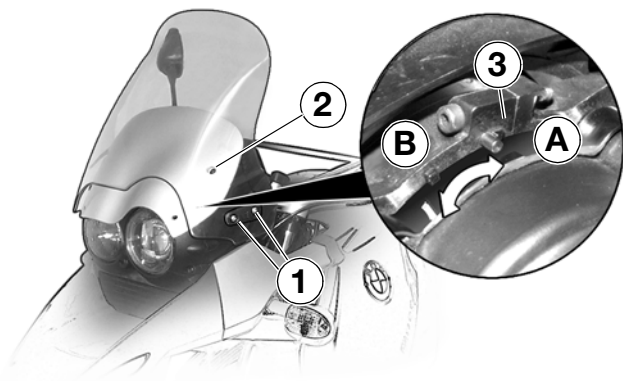

Headlight beam setting for riding on left/right

- Make sure the ground is level and firm and lift the motorcycle onto its centre stand
- Remove the two screws **1** securing the windscreen at each side
- Remove the windscreen
- Remove 2 screws **2** securing the fairing
- Remove the fairing
- Slacken clamp screw **3**
- Press the headlight against the stop
 - Left stop **A** for driving on left
 - Right stop **B** for driving on right
- Retighten clamp screw **3**
- Reinstall cover, fairing and windscreen: installation is the reverse of the removal procedure

Headlight guard^{OA}

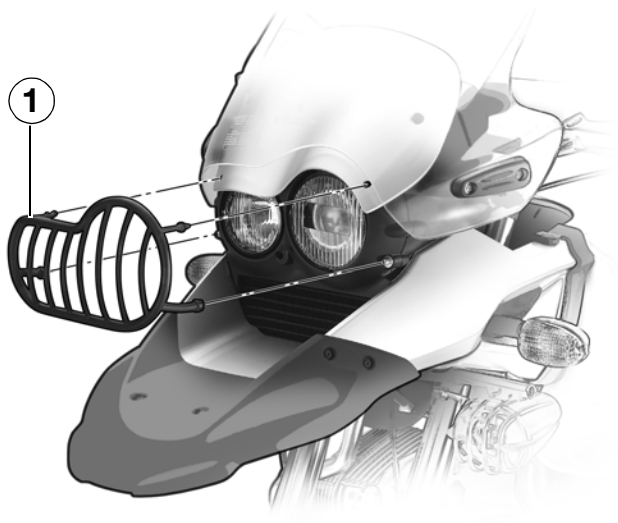

2

37

Maintenance and care

R 1150 GS Adventure



Note:

Headlight guard **1** is not approved for use on public roads.

If the bulb for the low-beam or high-beam headlight requires replacement, pull headlight guard **1** forward and off the lamp housing.

Fog lamps^{OA}

2

38

Maintenance and care

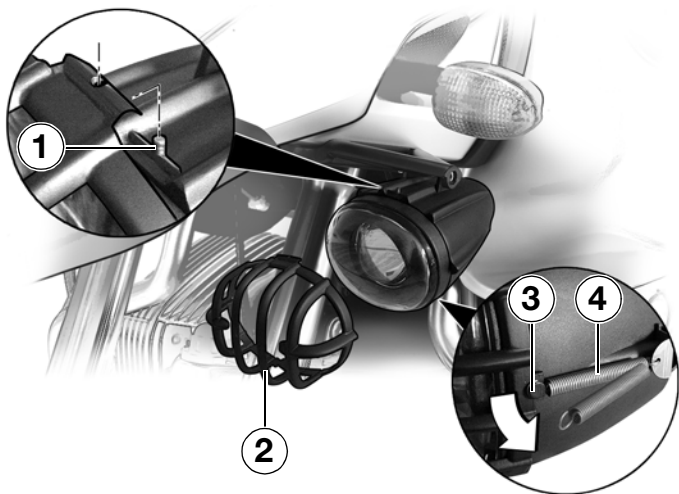

R 1150 GS Adventure

Cleaning lenses



Warning:

Risk of injury. The housing becomes hot if the fog lamps are on for a lengthy period of time.

- Disengage spring **4** from holder **3** on mesh guard **2** (arrow)



Caution:

When removing and installing mesh guard **2**, take care not to damage it on locating pin **1**.

- Carefully pull bottom edge of mesh guard **2** forward and pull it off over locating pin **1**
- Clean the lenses
- Installation of the mesh guard is the reverse of the removal procedure.

Your motorcycle is equipped with Digital Motor Electronic (MOTRONIC) engine management and a high-power ignition system.



Warning:

Work on the electrical system only when the circuit has been interrupted (switch off ignition and light). For greater safety, disconnect and insulate the negative battery lead. Do not touch any electrically live components when the engine is running or when the ignition is switched on!
– Risk of fatal accident!



Caution:

Your vehicle has a high-beam/low-beam bulb, a parking light bulb, a brake-light bulb/rear-light bulb, and four bulbs for the flashing turn indicators.

If any of these bulbs should fail, you may have problems in seeing and being seen.

You should therefore always carry spare bulbs on the motorcycle.



Note:

Do not touch the glass of new bulbs with your fingers. Use a clean, dry cloth to hold the bulbs when inserting them. Dirt deposits, in particular oil and grease, interfere with heat radiation from the bulb. This leads to overheating and shortens the bulb's operating life.

Changing bulbs

2

40

Maintenance and care

Tail light/brake light



Caution:

Switch off the ignition before changing a bulb.



Note:

Motorcycle with BMW Integral ABS^{OE} only:

The dimmed brake light takes over the function of the rear light should the rear light fail. A warning lamp lit in the cockpit indicates that this is the case. (► Rider's Manual, Chapter 3).

Do not touch the glass of new bulbs with your fingers. Use a clean, dry cloth to hold the bulbs when inserting them.

^{OE} Optional extra

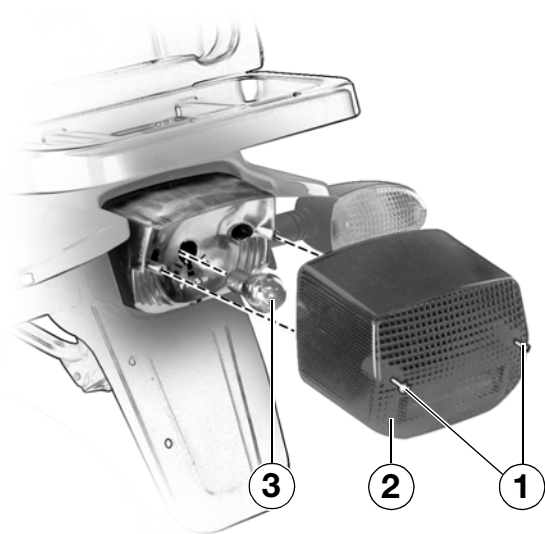

- Make sure the ground is level and firm and lift the motorcycle onto its main stand
- Remove securing screws **1**
- Remove tail-light glass **2**
- Press bulb **3** forwards and turn the bulb counter-clockwise to the left to release
- Remove the bulb
- Installation is the reverse of the removal procedure
 - Brake/rear light bulb **3**:
12 V 21/5 W

Changing bulbs

2

42

Maintenance and care

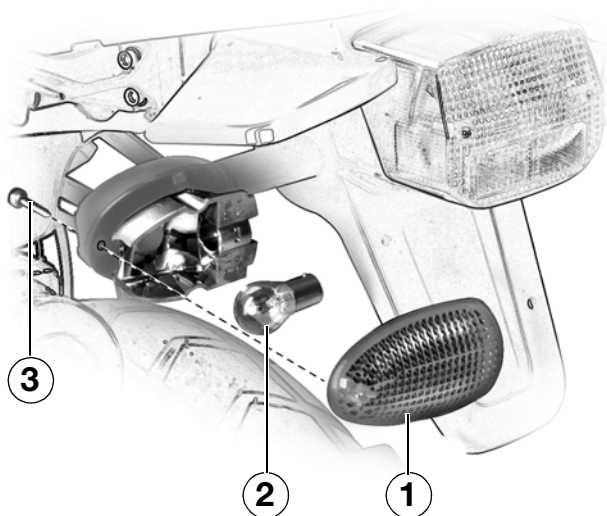

Flashing turn indicator



Caution:

Switch off the ignition before changing a bulb.



Note:

Do not touch the glass of new bulbs with your fingers. Use a clean, dry cloth to hold the bulbs when inserting them.

- Make sure the ground is level and firm and lift the motor-cycle onto its centre stand
 - Remove retaining screw **3**
 - Take off turn indicator glass **1**
 - Press bulb **2** in and turn it counter-clockwise to disengage it from the socket
 - Remove the bulb
 - Installation is the reverse of the removal procedure
- Bulbs for front/rear turn indicators **2: 12 V 21 W**

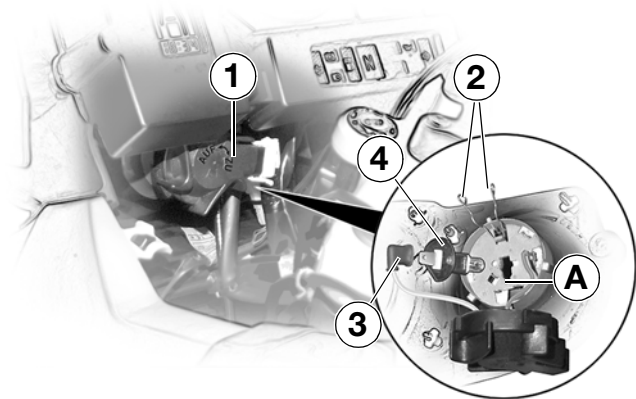

Low beam



Caution:

Switch off the ignition before changing a bulb.



Note:

Do not touch the glass of new bulbs with your fingers. Use a clean, dry cloth to hold the bulbs when inserting them.

- Make sure the ground is level and firm and lift the motor-cycle onto its centre stand
- Turn the handlebars to the left
- Turn left cover **1** counter-clockwise to disengage and swing it down
- Release spring clips **2** from retainer **A** at left and right and swing clips upwards
- Remove the H1 bulb **4**
- Disconnect cable **3** from H1 bulb **4**
- Installation is the reverse of the removal procedure
 - Low (dipped) beam **4**:
H1 12 V 55 W

Changing bulbs

2

44

Maintenance and care

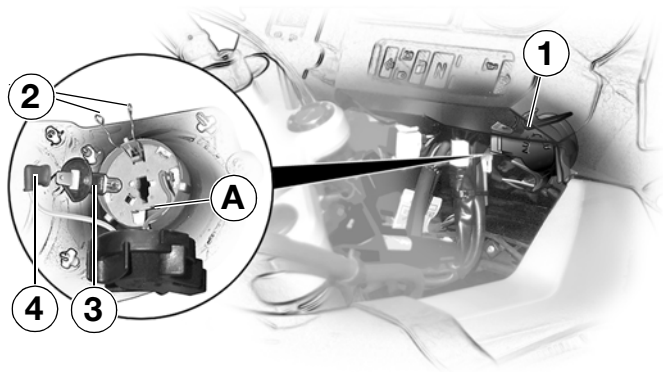

High-beam headlight



Caution:

Switch off the ignition before changing a bulb.



Note:

Do not touch the glass of new bulbs with your fingers. Use a clean, dry cloth to hold the bulbs when inserting them.

- Make sure the ground is level and firm and lift the motor-cycle onto its centre stand
- Turn the handlebars to the right
- Turn right cover **1** counter-clockwise to disengage and swing it down
- Release spring clips **2** from retainer **A** at left and right and swing clips upwards
- Take out the H1 bulb **3**
- Disconnect cable **4** from H1 bulb **3**
- Installation is the reverse of the removal procedure
 - High (main) beam **3**:
H1 12 V 55 W

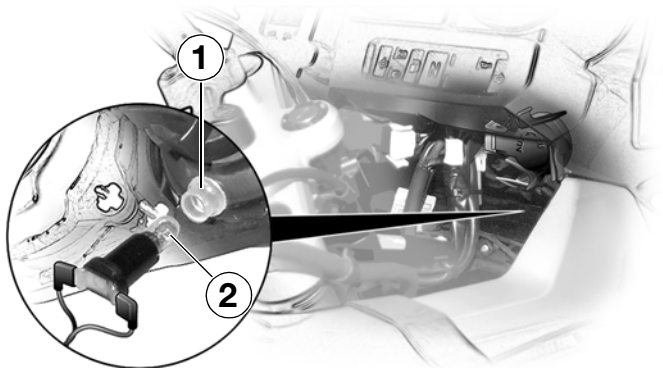

Parking light



Caution:

Switch off the ignition before changing a bulb.



Note:

Do not touch the glass of new bulbs with your fingers. Use a clean, dry cloth to hold the bulbs when inserting them.

- Make sure the ground is level and firm and lift the motorcycle onto its centre stand
 - Pull bulb holder **1** down and out of the headlight housing
 - Remove bulb **2** by pressing it in and turning it counter-clockwise at the same time
 - Installation is the reverse of the removal procedure
- Parking light **2: 12 V 4 W**

Changing bulbs

2

46

Maintenance and care

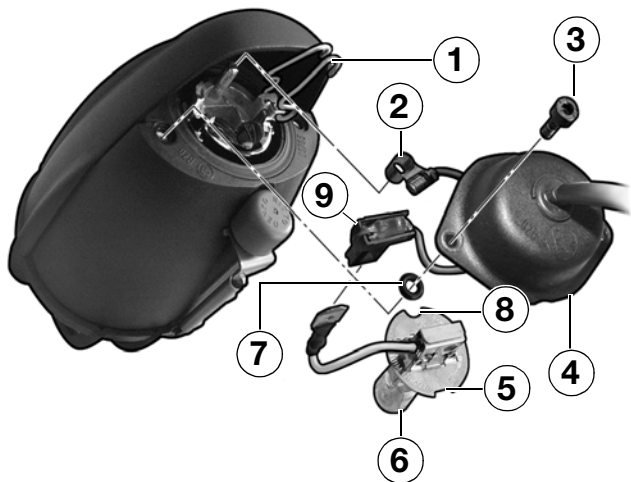

R 1150 GS Adventure

Fog light^{OA}



Warning:

Risk of injury. The housing becomes hot if the fog lights are on for a lengthy period of time.



Caution:

Switch off the ignition before changing a bulb.



Note:

Do not touch the glass of new bulbs with your fingers. Use a clean, dry cloth to hold the bulbs when inserting them.

- Remove two securing screws **3**
- Pull cap **4** to the rear to remove
- Disconnect ground cable **2** and plug and socket connection **9**

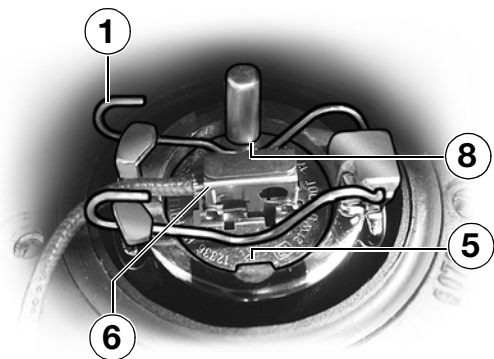

- Disengage clip **1** by pushing it toward the bulb holder and out at the same time
- Remove bulb **6**
- Installation is the reverse of the removal procedure

**Note:**

When installing, make sure that the grooves in the bulb are correctly positioned.

- Round groove **8** at top
- Angular groove **5** at bottom

**Note:**

Clean sealing rings **7** and check for damage; replace if necessary

- Fog light bulbs^{OA} **6**:
H3 12V 55 W

Replacing fuses

2

48

Maintenance and care

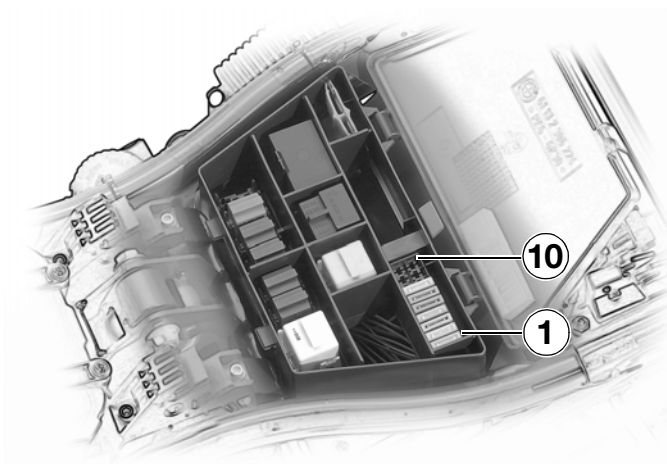

Caution:

Before changing a fuse, switch off the ignition.

Never attempt to repair a blown fuse – risk of fire!

For this reason, always carry a number of spare fuses on the motorcycle.

Use only fuses of the specified rating and type.

Equipment connected to fuses

- 1** Instrument cluster, indicator damping, brake light, without BMW integral ABS.. 4 A
- 2** Parking light, tail light.... 4 A
- 3** RID, power socket 15 A
- 4** Horn 7.5 A
- 5** Engine electronics, diagnosis plug 10 A
- 6** Fuel pump 10 A
- 7** Heated handlebar grips 4 A
- 8** Not assigned
- 9** Not assigned
- 10** Not assigned

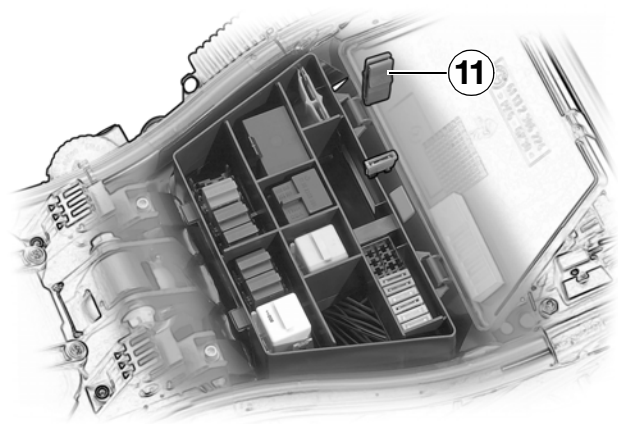

Replacing fuses

- Make sure the ground is level and firm and lift the motorcycle onto its centre stand
- Remove the seat
- Disengage and remove the cover of the central electrical equipment box
- Use the tweezers **11** supplied to pull the blown fuse out of its holder
- Install a new fuse of the correct amperage (➔ 48)
- Close the lid of the central electrical equipment box
- Close and lock the seat



Note:

It is advisable to have the motorcycle checked by a specialist workshop, preferably an authorised BMW motorcycle dealer if fuses blow frequently.

Changing spark plugs

2

50

Maintenance and care

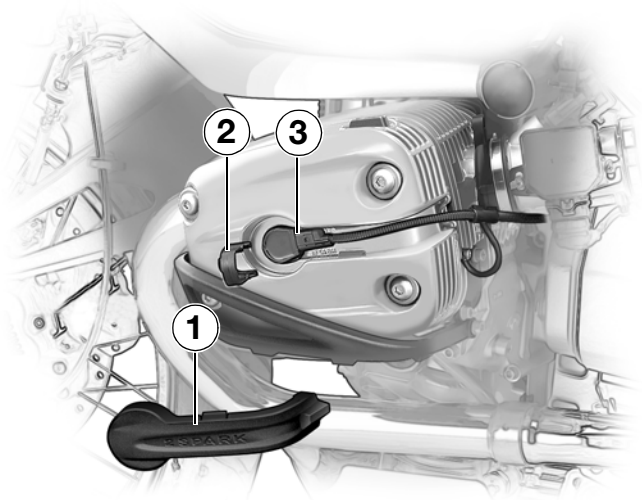

Warning:

Work on the electrical system only when the circuit has been interrupted (switch off ignition). For greater safety, disconnect and insulate the negative battery lead.

When the engine is running or the ignition is switched on, do not touch electrically live components, terminals or wiring.

- Risk of fatal accident!

Your motorcycle is equipped with Digital Motor Electronic (MOTRONIC) engine management and a high-power ignition system.

Removing spark plugs

- Make sure the ground is level and firm and place the motorcycle on its side stand
- Remove spark plug cover **1**
- Using puller **2** (➡ 19), remove direct ignition coil **3**

Changing spark plugs

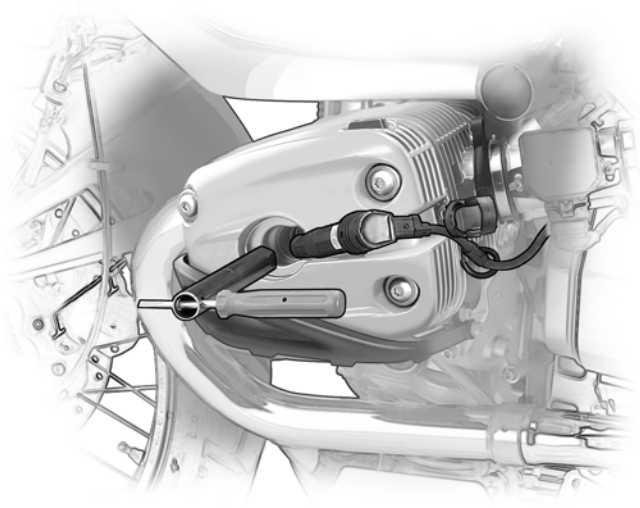

- Use spark plug spanner (➡ 19) and screwdriver to remove the spark plug
- Installation is the reverse of the removal procedure



Note:

Engage spark plug cover **1** at the rear first, then engage the front of the cover.



Caution:

Always have the tightening torques checked by a specialist workshop, preferably an authorised BMW motorcycle dealer.



Tightening torque:

(Engine cold)

Spark plugs, new 30 Nm
Spark plugs,
used 20 Nm

Changing spark plugs

2

52

Maintenance and care

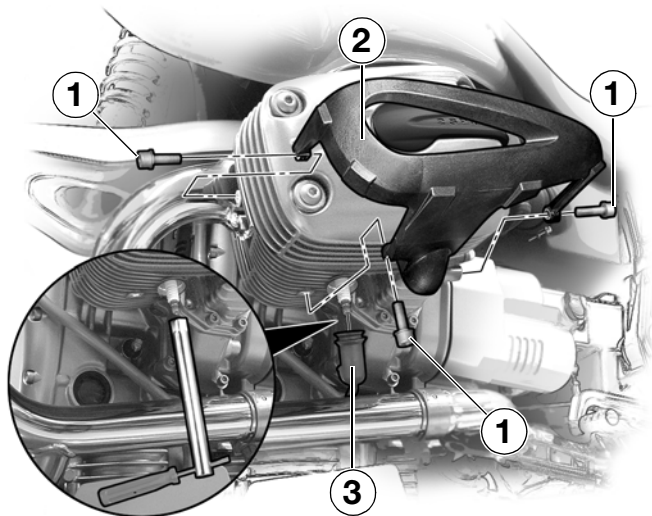

Replacing secondary spark plug

- Place the motorcycle on the centre stand, after making sure that the ground is level and firm
- Remove 3 securing screws **1**
- Remove spark-plug cover **2**
- Remove spark-plug cap **3**

- Use spark plug wrench and screwdriver to remove the spark plug.
- Installation is the reverse of the removal procedure



Tightening torque:

(Engine cold)

Secondary spark plugs 20 Nm

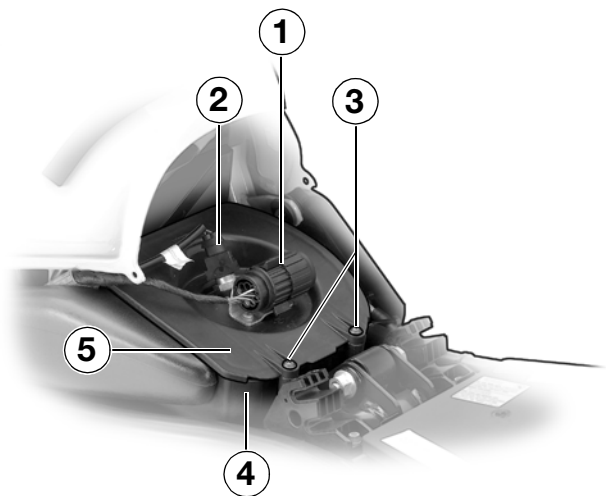

Replacing air filter element

- Place the motorcycle on its main stand
- Remove the seat
- Remove diagnosis connector **1** from its holder
- Disconnect plug **2** of the air-filter temperature sensor
- Unscrew two securing screws **3** in air-filter housing **4**

**Note:**

Securing screws **3** remain in air-filter cover **5**.

Air filter

2

54

Maintenance and care

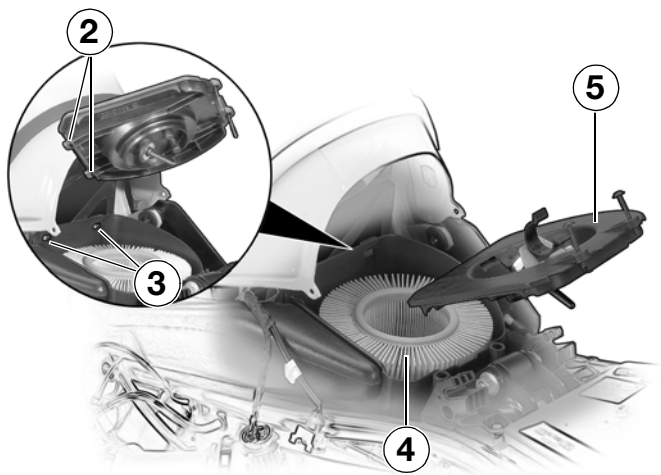

- Raise air filter cover **5** at the rear and remove it from the air filter housing.
- Remove old filter element **4** from the air filter housing
- Place the new filter element in position inside the air filter housing
- Installation is the reverse of the removal procedure



Note:

When installing, position the air filter cover as illustrated and engage pins **2** in the tabs **3** on the air filter housing. Close the cover.

Gel batteries are maintenance-free. Compliance with the instructions below is important in order to maximise battery life:

**Caution:**

- Keep the surface of the battery clean and dry
- Do not attempt to open the battery
- Do not attempt to top up the battery with water
- Use only electronically controlled battery chargers with a limit voltage of 14.4 V to charge the battery.

Correct upkeep, recharging and storage will prolong the life of the battery and are essential if warranty claims are to be considered.

**Warning:**

Do not attempt to jump-start the motorcycle using the on-board socket

- **Risk of fire!**
- **Push-start the motorcycle only when the engine is cold.**

The load capacity of the electrical wiring to the power socket is not sufficient to start the motorcycle from an outside source.

**Caution:**

Do not attempt to jump-start the motorcycle if the battery is completely flat: recharge the battery instead.

Risk of damaging the control units.

Motorcycle out of use for a lengthy period

- The battery has to be charged prior to lay-up periods of more than one month.



Caution:

If the battery is not disconnected, the on-board electronics (clock, etc.) will discharge the battery. This can cause the battery to run flat. If this happens, warranty claims will not be accepted.

Disconnect the ground (earth) lead from the battery prior to a lay-up.

- Batteries that are not in use must be stored in a cool place. Do not store a discharged battery
- If the battery is in storage for an extended period of time, recharge it at regular intervals of approx. 4 months. If the battery is not disconnected from the motorcycle's systems, recharge it every 2 months at the latest
- Always fully recharge the battery before restoring it to use

In case of doubt ask a specialist, preferably an authorised BMW motorcycle dealer, to prepare the vehicle for laying up and to carry out the necessary battery maintenance and storage

Removing and installing battery

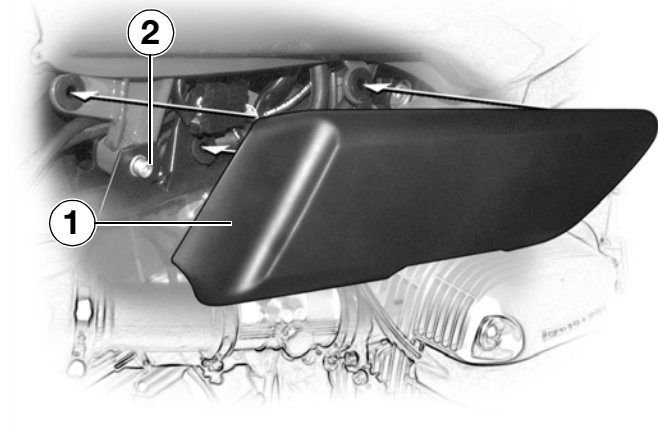

Removing the battery



Warning:

Avoid damage to fuel tank, wiring and hoses during removal work.

Before disconnecting the battery, switch off the ignition.

To avoid short-circuits:

- First disconnect the **negative** battery lead (-) ,
- then the **positive** battery lead (+).
- Make sure the ground is level and firm and lift the motorcycle onto its centre stand
- Remove the seat
- Remove right side panel **1**
- Remove fuel tank retaining screw **2**
- Pull the tank slightly to the rear, raise and support it

Removing and installing battery

2

58

Maintenance and care

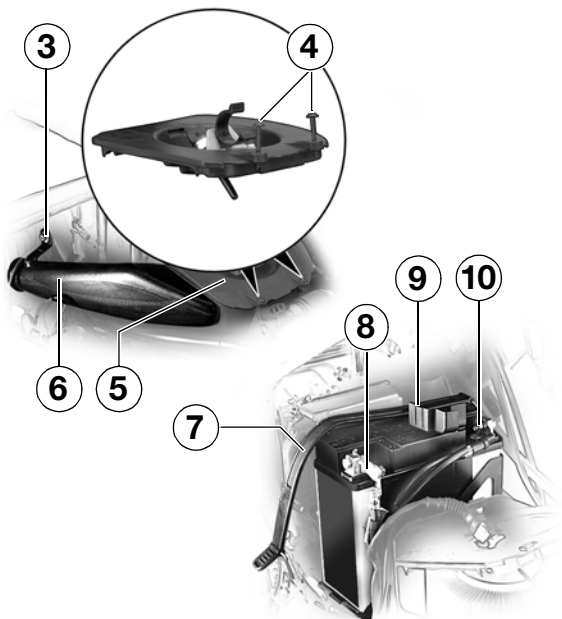

- Remove retaining screw **3** for air intake pipe
- Release clips **4** from air filter housing
- Open air filter cover **5**
- Remove air intake pipe **6**
- Release battery retaining strap **7**
- Disconnect the battery **negative** cable **8**
- Using a screwdriver, open protective cap **9** for the positive battery post
- Disconnect **positive** battery cable **10**
- Pull the battery out to the left

Removing and installing battery

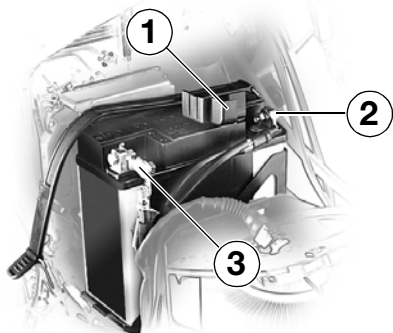

Installing battery

Installation of the battery is the reverse of the removal procedure.



Warning:

Before connecting the battery, switch off the ignition.

To avoid short-circuits:

- **Connect the positive battery lead (+) 2 first**
- **Close protective cap 1 for the positive battery pole**
- **Never install the battery without the protective cap**
- **Connect negative battery lead (-) 3**

Removing and installing battery

2

60

Maintenance and care



Caution:

Always have the tightening torques checked by a specialist workshop, preferably an authorised BMW motorcycle dealer.



Tightening torque:

Battery-terminal clips 3.5 Nm



Note:

Disconnecting the battery deletes all entries (e.g. faults, settings) stored in the Motronic control unit's memory. Loss of settings can temporarily impair the operating characteristics when the engine is re-started.

- Switch on the ignition
- Fully open the throttle once or twice
- The Motronic registers the throttle-valve positions

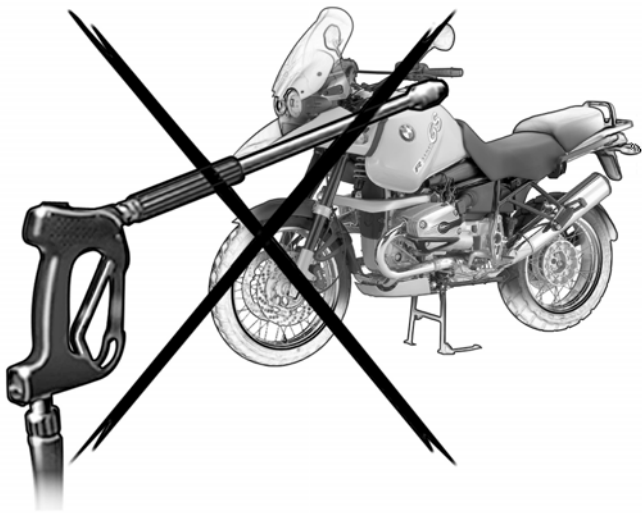
**Caution:**

Avoid damage to rubber or plastic parts caused by aggressive or penetrating cleansing agents or solvents.

Do not use a steam jet or high-pressure cleaning equipment. High water pressure can damage seals, the hydraulic brake system and the electrical system.

**Note:**

Regular cleaning, using the correct methods, is an important factor in maintaining the value of your motorcycle.

It also ensures that safety-relevant parts remain in full working order.



Washing the motorcycle



Warning:

After cleaning or before starting a journey, always test the brakes.

- Make sure the ground is level and firm and lift the motorcycle onto its main stand
- Clean the wheels, engine, gearbox and swinging arm with a mild detergent, following its manufacturer's instructions
- Thoroughly dry all wet surfaces
- Do not use solvents or cleaning products to wash the instrument cluster, switches and windscreen – do not scratch the windscreen
- Remove tar splashes only with an approved cleansing agent – rinse the affected area thoroughly
- Clean dead flies and other insects or similar dirt deposits off the fixed fork tubes
- Treat painted and chromed parts regularly with suitable care products



Removing road salt

- Wash the motorcycle down immediately with cold water at the end of the journey



Note:

Do not use warm water – warm water aggravates the effect of the salt.

- Thoroughly dry the motorcycle
- Apply a wax-based corrosion-proofing product to chrome-plated parts
- Coat/polish fairing elements after cleaning and drying with a recommended wax

Cleaning the windscreen



Caution:

Do not use detergent products. Fuel or chemical solvents attack the windscreen material.

- Remove dirt and dead insects with a soft sponge and plenty of water



Note:

Soften stubborn dirt or insects by soaking with a wet kitchen towel.



Touching up paint damage



Caution:

Comply with the manufacturer's working instructions and safety precautions.

- Minor damage caused by stones striking the painted surface can be touched up with a BMW paint pencil of the correct colour



Note:

More extensive damage should be attended to by a specialist workshop, preferably an authorised BMW motorcycle dealer.

Care of exhaust silencer

- Changes in the appearance of the exhaust system (these may be unavoidable for operating or environmental reasons) should be treated with "Metal Polish" from the Autosol company, BMW order number 82 14 9 400 890



Laying up

- Clean the motorcycle (➡ 62-64)
- Remove the battery (➡ 57-59)
- Spray the clutch lever pivots and the main and side stand pivots with a suitable lubricant.
- Coat bright metal/chrome-plated parts with an acid-free grease (e.g. Vaseline)
- Place the motorcycle on its centre stand in a dry room
- Support the motorcycle under the engine so that the wheels are not taking any weight



Note:

Before laying the vehicle up out of use have the engine oil and the oil filter element changed by a specialist workshop, preferably your authorised BMW dealer.

It is always a good idea to combine the preparations for a lay-up and the post lay-up work with a service check or inspection by a specialist workshop, preferably your authorised BMW motorcycle dealer.



Restoring to use

- If necessary, remove protective wax coating
- Clean the motorcycle (➡ 62)
- Install a charged battery (➡ 59)
- Perform safety checks (Rider's Manual ➡ 28-57)
- Check the brakes (Rider's Manual ➡ 36-44)
- Check/correct tyre pressures (Rider's Manual ➡ 54)

R 1150 GS / GS Adventure

Type

Air-cooled flat-twin ("Boxer") with additional oil cooling in the exhaust valve areas and a single side-mounted, chain-driven camshaft on each side, operating 4 valves per cylinder by means of tappets and short pushrods; wet sump lubrication.

Displacement	1130 cc
Max. output to DIN 70 020	
	62 kW
- at engine speed	6750 min ⁻¹
Max. torque	98 Nm
- at engine speed	5250 min ⁻¹
Permissible engine speeds	
maximum	7900 min ⁻¹
idle speed	1100 ±50 min ⁻¹
Bore/stroke	101/70.5 mm (3.98/2.78 in)
Compression ratio	10.3 : 1
Fuel consumption to ISO 7118	
- at steady 90 km/h (56 mile/h)	4.5 l/100 km (62.5 mile/Imp. gal)
- at steady 120 km/h (75 mile/h)	5.7 l/100 km (49.5 mile/Imp. gal)
Maximum oil consumption	1 l/1000 km (1.41 Imp. pint/500 miles)

Power train

3

68

Technische Daten

R 1150 GS / GS Adventure

Clutch

Lightweight single-plate dry clutch mounted on crankshaft, with increased-leverage diaphragm spring and starter gear ring. Hydraulic operation.

Clutch plate \emptyset

165 mm (6.50 in)

Manual gearbox

6-speed with claw shift and integral torsional vibration damper

Gear ratios

1st gear = 3,864 / 4,465^{OE}

2nd gear = 3.022

3rd gear = 2.393

4th gear = 1.962

5th gear = 1.700

6th gear = 1,316 / 1,504 (Adventure)

Gearbox to rear wheel

By shaft protected within hollow swinging arm of Paralever rear suspension, with integral torsional vibration damper and two universal joints.

Final drive

Crown wheel and pinion with Palloid teeth, running in anti-friction bearings; rear wheel directly flange-mounted to rear of crown wheel.

Final drive ratio

1 : 2.82

R 1150 GS / GS Adventure

Frame

Three-part frame. A cast aluminium front frame connects the load-bearing engine and gearbox assembly to the tubular steel rear frame. A forged aluminium footrest plate increases the strength of the gearbox mount.

Location of type plate and frame number

On right of front frame

Front brake

Hydraulically operated twin disc brake with 4-piston fixed calipers, angular wear compensation and floating stainless-steel brake discs.
Sintered metal brake-pad linings

Rear brake

Hydraulically actuated disc brake with floating caliper and stainless steel disc.
Semi-metal brake-pad linings
BMW Integral ABS^{OE}:
Sintered metal brake-pad linings

Frame and suspension

R 1150 GS / GS Adventure

Wheel location

Front Light-touch wheel guidance (Tele-lever) with central suspension strut.

Rear Cast aluminium single swinging arm with additional torque reaction strut to compensate for shaft drive effects (Paralever); central suspension strut.

Steering lock angle 2 x 42°

Front wheel castor

- at unladen weight 108 mm (4.25 in)

- in normal-load position 115 mm (4.53 in)

Frame and suspension

	R 1150 GS	GS Adventure
Front suspension	Central spring strut with progressive-rate coil spring (with taper-wound ends) and twin-tube, gas-filled shock absorber. Five-position spring preload adjustment.	
Spring travel (bump)	122 mm (4.80 in)	137 mm (6.5 in)
Spring travel (rebound)	68 mm (6.5 in)	73 mm (2.9 in)
Total travel	190 mm (7.5 in)	210 mm (8.26 in)
Fixed tube diameter	35 mm (1.34 in)	35 mm (1.34 in)
Front wheel caster in normal-load position	115 mm (4.53 in)	121 mm (4.76 in)
Rear suspension	Central spring strut with coil spring and single-tube, gas-filled shock absorber. Continuously variable rebound damping setting.	
	Spring preload adjustable by hydraulic cylinder.	
Spring travel (bump)	135 mm (5.32 in)	150 mm (5.906 in)
Spring travel (rebound)	65 mm (2.56 in)	70 mm (2.76 in)
Total travel (at wheel)	200 mm (7.9 in)	220 mm (8.66 in)
Swinging arm length	506 mm (19.92 in)	506 mm (19.92 in)

Frame and suspension

3

72

Technische Daten

Wheels and tyres

R 1150 GS / GS Adventure

BMW cross-spoke wheels, low aspect-ratio tyres

Front wheel

Angled rim shoulder and double tyre retaining hump

Size and designation

2.50 x 19 MT H2

Tyre size and designation

110/80 R19 59H
TUBELESS

Massive-bar tyre, Conti TKC 80^{OE}

Rear wheel

Angled rim shoulder and double tyre retaining hump

Size and designation

4.00 x 17 MT H2

Tyre size and designation

150/70 R17 69H
TUBELESS

Massive-bar tyre, Conti ZKC 80^{OE}

Frame and suspension

R 1150 GS / GS Adventure

Tyre pressures (with tyres cold)

Solo	Front	2.20 bar (31.9 psi)
	Rear	2.50 bar (36.3 psi)
Two-up	Front	2.50 bar (36.3 psi)
	Rear	2.70 bar (39.2 psi)
Two-up with luggage	Front	2.50 bar (36.3 psi)
	Rear	2.90 bar (42.0 psi)

Recommended minimum tyre tread depth

Front wheel	2 mm (0.08 in)
Rear wheel	3 mm (0.12 in)



Warning:
**Comply with legal limits
concerning the minimum permis-
sible tyre tread depth.**

Fuel and lubricants

R 1150 GS / GS Adventure

Engine oil

Brand-name HD oil, API classification SF, SG or SH; CD or CE suffixes are permissible; alternatively, brand-name HD oil, CCMC classification G4 or G5; suffix PD2 is permissible.

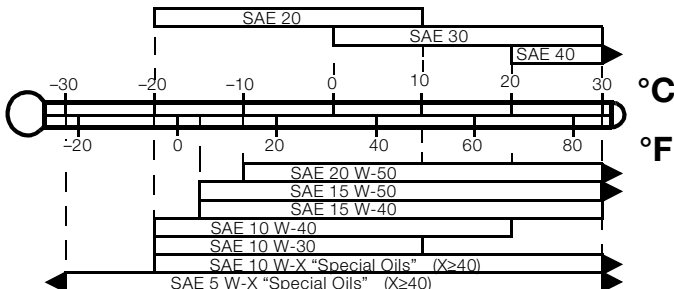

The viscosity class depends on outside temperatures. Temperatures above or below the limits quoted for the individual SAE classifications are permitted for brief periods only. "Special Oils" are approved individually by BMW AG and available from your authorised BMW motorcycle dealer. All engine oils supplied by BMW are subjected to regular BMW quality assurance checks. BMW does not approve the use of upper-cylinder lubricants or similar oil additives.

Engine oil capacity

- without filter replacement 3.50 l (6.2 Imp. pints)
- if filter is replaced 3.75 l (6.6 Imp. pints)

Gearbox oil	R 1150 GS / GS Adventure Brand-name hypoid gear oil, API class GL 5
Capacity	
Gearbox	approx. 1.0 l (1.06 pints) (to bottom edge of filler opening)
Rear wheel drive	approx. 0.25 l (0.44 pints) (to bottom edge of filler opening)
Viscosity class	EPX 90, or alternatively SAE 90 API
Fuel grade	Super (premium) unleaded fuel to DIN 51 607 standard, minimum octane number 95 (RON)
Fuel tank capacity (usable)	22 l (5.3 gal) / 30 l (6.6 gal) ^{OE} including approx. 4 l (0.88 gal) reserve

Bearings and other lubrication points

R 1150 GS / GS Adventure

Brand-name anti-friction bearing grease, usable temperature range $-25^{\circ}\text{C} \dots +120^{\circ}\text{C}$, drip point 190°C , high corrosion protection, good resistance to water and oxidation; e.g. Shell Retinax EP2

Brake fluid

DOT 4

We recommend BMW brake fluids



Caution:

Use only new brake fluid to DOT 4 specification.

Electrical system

R 1150 GS / GS Adventure

Battery

Gel battery, 12 V 19 Ah
maintenancefree

Spark plugs

Approved makes/types

Primary spark plug

NGK BKR 7 EKC

Secondary spark plug

Bosch YR6LDE or
NGK DCPR 8 EKC

Electrode gap

0.8 mm (0.03 in)

Wear limit

1.0 mm (0.04 in)

Fuses

"Minifuse" flat-socket fuses

Load ratings

4 A, 7.5 A, 10 A and 15 A

Headlight

Twin halogen headlights

Bulbs

High (main) beam headlight

H1 halogen bulb, 12 V 55 W

Low-beam headlight (riding light)

H1 halogen bulb, 12 V 55 W

Fog light^{OA}

H3 halogen bulb, 12 V 55 W

Parking light

DIN 72 601 12 V 4 W
Standard designation T 8/4

Combined brake and rear light

DIN 72 601 12 V 21/5 W
Standard designation P 25-2

Flashing turn indicators

DIN 72 601 12 V 21 W
Standard designation P 25-1

Turn indicator repeaters

DIN 72 601 12 V 4 W
Standard designation T 8/4

Other telltale lights, instrument lighting

DIN 72 601 12 V 3 W
Standard designation W 10/3

Power socket

(GS Adventure only)

12 V 5 A for connecting GPS,
Roadbook, Tripmaster etc.

^{OA} Optional accessories

Dimensions and weights

3

78

Technische Daten

	R 1150 GS	GS Adventure
Overall length	2190 mm (86.2 in)	2180 mm (85.83 in)
Width		
- across mirrors	945 mm (37.2 in)	980 mm (38.58 in)
- across handlebars (with ends)	903 mm (35.6 in)	903 mm (35.6 in)
- across rider's footrests	602 mm (23.7 in)	602 mm (23.7 in)
- across pillion passenger's footrests	734 mm (28.9 in)	735 mm (28.94 in)
Overall height (excl. mirrors)	1420 +10 mm (55.9 +0.39 in)	1435 mm (56.5 in)
Seat height, unladen	840/860 mm (33.1/33.9 in) adjustable to 2 positions	900 mm (35.43 in)
Wheelbase		
- in normal-load position	1515 mm(59.6in)	1501mm(49.09in)
Ground clearance		
- in normal-load position	200 mm (7.9 in)	220 mm (8.66 in)
Unladen weight (ready to ride, tank full)	249 kg (549 lb)	253 kg / 276.5 kg (558 lb / 609.6 lb) with all oe
Dry weight	228 kg (503 lb)	232 kg (511 lb)
Gross weight limit	460 kg (1014 lb)	460 kg (1014 lb)
Permissible wheel loads		
Front	180 kg (397 lb)	180 kg (397 lb)
Rear	300 kg (661 lb)	300 kg (661 lb)

Performance data

	R 1150 GS	GS Adventure
Top speed		
acc. to type approval test	196 km/h (122 mph)	192 km/h (119 mph)
with massive-bar tyres ^{OE}	160 km/h (99 mph)	160 km/h (99 mph)
Flexibility		
4th gear, 80-120 km/h (50-75 mph)	3.44 s	3.44 s
5th gear, 80-120 km/h (50-75 mph)	4.37 s	4.37 s
6th gear 80-120 km/h (50-75 mph)	6.91 s	4.88 s
4th gear, 60-140 km/h (37-87 mph)	7.1 s	7.20 s
5th gear, 60-140 km/h (37-87 mph)	8.6 s	8.80 s
6th gear, 60-140 km/h (37-87 mph)	13.6 s	10.20 s
Power-weight ratio		
ready for road + rider (85 kg/187 lbs)	5.39 kg/kW (13.74 lbs/kW)	4.048 kg/kW(8,9 lb/ kW) 4.424 kg/kW (9.7 lb/kW) w. all OE
at gross weight limit	7.42 kg/kW (16 lbs/kW)	7.42 kg/kW (16 lbs/kW)
Ride-past noise level		
acc. to 78/1015/EU mod.	80 dB (A)	80 dB (A)
Drag coefficient		
cd x A , rider upright	0.536	0.536
cd x A , rider crouched	0.518	0.518

^{OE} Optional extra

A

- Accessories, genuine BMW parts, 18
- Annual Service, confirmation of maintenance work, 11
- Annual Service, instructions, 3
- Anziehdrehmomente
Bremsattel, 51

B

- Batterie
Ausbau, 53, 57
- Battery
charging, 55
installing, 59
technical data, 77
warranty, 55
- Blinker, 42
- Bore/stroke, 67
- Brakes
brake fluid, 76
Minimum brake pad thickness, 34
pad wear indicating marks, 34
technical data, 69
- Bulbs
changing
flashing turn indicator, 42
high-beam headlight, 44
low beam, 43
parking light, 45
tail/brake light, 40
information, 39
technical data, 77

C

- Capacities
engine, 74
engine oil, 74
- Capacity
gearbox, 75
- Castor, 70
- Cleaning/care
general instructions, 61, 63
- Clutch, 68
- Compression ratio, 67
- Confirmation of odometer replacement, 15
- Confirmations of maintenance work
inspection, 6
service, 6

D

- Dimensions, 78
- Displacement, 67
- Drag coefficient, 79

E

- Electrical system, 77
- Engine maximum speed, 67
- Engine oil
consumption, 67
technical data, 74
viscosity, 74
- Engine oil capacity, 74
- Engine size, 67
- Engine speed limits, 67
- Engine, type, 67
- Exhaust system, care of, 64

- F**
Flexibility, 79
Fog lamps, 38
Frame, 69
Front wheel
 installing, 25, 26, 27
 removing, 22
 technical data, 72
Front wheel stand, 22
Fuel
 grade, 75
Fuel and lubricants, 74, 76
Fuel consumption, 67
Fuels and lubricants, 75
Fuses
 load ratings, 77
- G**
Gearbox
 capacity, 75
 oil capacity, 75
 oil grades, 75
 ratios, 68
 technical data, 68
General instructions, 16, 17
Gross weight, 78
Ground clearance, 78
- H**
Headlight guard, 37
- I**
Idle speed, 67
Inspection (Running-in Check),
 Notes, 3
Inspection 1000 km/600 miles, 3
Installing brake caliper
 Rear wheel, 51, 52, 60
- L**
Lackschäden ausbessern, 64
Laying up, 65
- M**
Maintenance schedule, 4, 5
Maintenance work, confirmation
 of, 7
Maintenance work, confirmation of
 (Annual Service), 11
- N**
Noise emissions, 79
- O**
Odometer replacement,
 confirmation of, 15
Oil capacity
 gearbox, 75
- P**
Pannenhilfesatz für
 Schlauchlosreifen, 19
Paralever, 70
Performance data, 79
Plastic parts
 cleaning, 61
Power output, 67
Power-weight ratio, 79

R

- Rear wheel
 - installing, 31, 32, 33
 - removing, 28, 29, 30
 - technical data, 72
- Rear wheel drive
 - technical data, 68
- Reifen
 - Pannenhilfesatz, 19
- Reinigen/Pflegen
 - Lackschäden, 64
 - Säubern, 62
 - Streusalz, 63
- Restoring to use, 66
- Rück-/Bremslicht, 40

S

- Safety information, 2
- Safety instructions, 16, 39, 50
- Salt damage, 63
- Scheinwerfereinstellung
 - Rechts-/Linksverkehr, 36
- Seat height, 78
- Service work, confirmations
 - of, 13, 14
- Service, instructions, 3
- Sicherungen
 - Belegung, 48
- Spark plugs, 77
- Speedometer drive, 24, 25
- Spring travel, 71
- Standlicht, 45
- Steering lock angle, 70
- Suspension
 - technical data, 71

T

- Technical data, from page, 67
- Technical modifications, 17
- Telelever, 70
- Tightening torque
 - Rear wheel, 51, 52
 - rear wheel, 33
- Tightening torques
 - front wheel, 27
 - front wheel brake caliper, 27, 33
 - Rear wheel, 60
- Tools, 19
- Top speed, 79
- Torque, 67
- Troubleshooting, 20
- Type plate, 69
- Tyre damage, 19
- Tyre tread depth, 73
- Tyres, 72
 - approved tyre sizes, 72
 - pressures, 73
 - technical data, 72
 - tread depth, 73

U

- Unladen weight, 78

W

- Weights, 78
- Wheel loads, 78
- Wheel location, 70
- Wheel rims, 72
- Wheelbase, 78
- Wheels, technical data, 72

Motorcycle data

Model

Frame No.

Colour No.

First registered on

Registration No.

Dealer data

Person to contact for Service work

Ms./Mr.

Tel. No.

Dealer's address with telephone No. (company stamp)

Details described or illustrated in this booklet may differ from the motorcycle's actual specification as purchased, the accessories fitted or the national-market specification. No claims will be entertained as a result of such discrepancies.

Dimensions, weights, fuel consumption and performance data are quoted to the customary tolerances.

The right to modify designs, equipment and accessories is reserved. Errors and omissions excepted.

©2002 BMW Motorrad

Not to be reproduced either wholly or in part without written permission from BMW Motorrad, After Sales.

Printed in Germany

BMW recommends Castrol



**BMW Motorrad
Printed information**

Order No.:
01 41 7 680 211
10.2002
6th edition GB / RF



**The Ultimate
Driving Machine**