

Service and Technical Booklet

R 1100 S



Please note



Warning:

This symbol stands for precautions and measures which are essential in order to protect the rider or other persons from possibly severe or fatal injury.



Caution:

Specific instructions and safety precautions intended to prevent damage to the motorcycle. Failure to comply with them could invalidate the warranty.



Note:

Specific instructions on how to operate, control, adjust or look after items of equipment on the motorcycle.

For safety reasons and to maintain the value of your motorcycle, regular maintenance intervals have been laid down. Always keep to the specified maintenance intervals. This is the only way to ensure that warranty claims are not invalidated. The contents of maintenance schedules can change for safety reasons, owing to changes of materials, for example.

Your authorised BMW motorcycle dealer can provide details of the currently specified Service, Inspection and Annual Service work needed.

Important:

BMW refuses to accept liability for damage or consequential damage due to repairs or service work carried out by other than BMW-authorised workshops.

Have maintenance work carried out by your authorised BMW motorcycle dealer's specially trained, expert personnel, and confirmed by an entry in the Service and Technical Booklet. Authorised BMW motorcycle dealers are supplied with the latest technical information and have the necessary technical know-how and specially trained staff.

Please do not hesitate to contact your authorised BMW motorcycle dealer on all matters concerning your motorcycle.

Authorised BMW motorcycle dealers are fully informed about all aspects of your motorcycle and will gladly advise and assist you.

Best wishes,

BMW Motorrad

Important safety information

1

2

BMW Service

For your own safety, use spare parts and accessories that have been approved by BMW.

If you choose genuine accessories and spare parts that have been tested and approved by BMW, you can be sure that the appropriate tests have been carried out to confirm their suitability for use on your motorcycle. BMW accepts full liability for these products.

Note however that BMW is unable to accept liability for spare parts and accessories which it has not approved.

BMW cannot assess every single product of outside origin in order to decide whether it can be used on or with a BMW vehicle without constituting a safety hazard.

Nor does an official inspection certificate or permit (such as the General Operating Permit) represent a sufficient guarantee in all cases, as the scope of testing may be inadequate.

Genuine BMW spare parts, BMW accessories and other products approved by BMW can be obtained from all authorised BMW motorcycle dealers, together with full advice and recommendations for their use.

Maintenance work is divided up into Service, Inspection and Annual Service.

BMW Inspection

1,000 km/600 miles

BMW Running-in Check after the first 1,000 km/600 miles.

BMW Service

After the first 10,000 km (6,000 miles) and every further 20,000 km (12,000 miles) (18,000 miles..., 30,000 miles ..., 42,000 miles... etc.)

BMW Inspection

After the first 20,000 km (12,000 miles) and every further 20,000 km (12,000 miles) (24,000 miles..., 36,000 miles ..., 48,000 miles... etc.)

BMW Annual Service

Certain items of maintenance work depend on elapsed time as well as the distance the motorcycle has covered. They should therefore be carried out at least once a year (e.g. renewing the brake fluid).

If these items cannot be carried out during a Service or an Inspection, an Annual Service must be performed.



Note:

Every BMW motorcycle dealer has a fixed scale of charges based on work times and carefully calculated hourly rates. Fuel, lubricants and similar substances, filters, gaskets etc. are charged separately.

Maintenance schedule

1

4

BMW Service

	BMW Inspection 1,000 km	BMW Service	BMW Inspection	BMW Annual Service
Read the fault code memory with the BMW MoDiTeC	X	X	X	X
(BMW Integral ABS) Perform bleed test with BMW MoDiTeC		X	X	
Change the engine oil while at regular operating temperature and replace the oil filter element 1) *)	X	X	X	X
Change the oil in the gearbox while at regular operating temperature 2) *)			X	X
Change the oil in the rear wheel drive while at regular operating temperature 3) *)	X		X	X
Renew the fuel filter 4) *)			X	
Check battery acid level and add distilled water if necessary; clean and grease battery posts			X	X
Renew the intake air filter element 5) *)			X	
Renew the Poly-V belt 6) *)			X	
Check brake fluid level at front and rear		X	X	
Check operation of brake system and freedom from leaks; repair/replace items if necessary *)			X	
Examine brake pads and discs for wear, replace if necessary *)		X	X	
(Without BMW Integral ABS) Change brake fluid every twelve months				X

Maintenance schedule

	BMW Inspection 1,000 km	BMW Service	BMW Inspection	BMW Annual Service
(BMW Integral ABS) Change brake fluid in wheel circuit every 12 months				X
(BMW Integral ABS) Change brake fluid in control circuit *)2)				X
(BMW Integral ABS) Perform bleed test with BMW MoDiTeC				X
Check clutch fluid level		X	X	
Change clutch fluid 2) *)			X	X
Check tightness of rear wheel studs	X			
Check rear wheel bearing play			X	
Check swinging arm bearings (freedom from play), adjust if necessary*)	X		X	
Grease the side stand pivot	X	X	X	
Check function of side-stand switch	X	X	X	X
Check condition of spark plugs		X		
Renew spark plugs			X	
Check security of cylinder head nuts	X			
Check/adjust valve clearances	X	X	X	
Check that the throttle cable moves freely and is free of kinks and chaffing, replace if necessary *)	X	X	X	
Check Bowden cable play	X	X	X	

Maintenance schedule

1

6

BMW Service

	BMW Inspection 1,000 km	BMW Service	BMW Inspection	BMW Annual Service
Check synchronisation and repair leaks if necessary *)	X	X	X	
Final inspection with road safety and functional check: trial run if necessary – Condition of tyres and wheels – Tyre pressure – Lights and signals – Telltale and warning lights – Instruments – Clutch, gear shift – Handbrake, foot brake, steering – Trial run if necessary	X	X	X	X
1) If the motorcycle is ridden for short distances only or at outside temperatures below 0 °C: every 3 months or after every 3,000 km (1,800 miles) at the latest 2) Every 2 years 3) Every 40,000 km (24,000 miles) or at the latest every 2 years 4) Normally every 40,000 km (24,000 miles), if fuel is of poor quality every 20,000 km (12,000 miles) 5) In very dusty or dirty conditions, replace the intake air filter element every 10,000 km (6,000 miles) or even more frequently 6) Replace the Poly-V belt every 60,000 km (36,000 miles); do not adjust it *) Charged as an additional item				

Confirmation of maintenance work

BMW Pre-delivery check

Carried out in accordance with
manufacturer's instructions

Odometer reading _____

Date, stamp, signature

BMW Service 10,000 km

Carried out in accordance with
manufacturer's instructions

Odometer reading _____

Date, stamp, signature

BMW Inspection 1,000 km

Carried out in accordance with
manufacturer's instructions

Odometer reading _____

Date, stamp, signature

BMW Inspection 20,000 km

Carried out in accordance with
manufacturer's instructions

Odometer reading _____

Date, stamp, signature

1

7

BMW Service

Confirmation of maintenance work

1

8

BMW Service

BMW Service 30,000 km

Carried out in accordance with
manufacturer's instructions

Odometer reading _____

Date, stamp, signature

BMW Service 50,000 km

Carried out in accordance with
manufacturer's instructions

Odometer reading _____

Date, stamp, signature

BMW Inspection 40,000 km

Carried out in accordance with
manufacturer's instructions

Odometer reading _____

Date, stamp, signature

BMW Inspection 60,000 km

Carried out in accordance with
manufacturer's instructions

Odometer reading _____

Date, stamp, signature

Confirmation of maintenance work

BMW Service 70,000 km

Carried out in accordance with
manufacturer's instructions

Odometer reading _____

Date, stamp, signature

BMW Service 90,000 km

Carried out in accordance with
manufacturer's instructions

Odometer reading _____

Date, stamp, signature

BMW Inspection 80,000 km

Carried out in accordance with
manufacturer's instructions

Odometer reading _____

Date, stamp, signature

BMW Inspection 100,000 km

Carried out in accordance with
manufacturer's instructions

Odometer reading _____

Date, stamp, signature

Confirmation of maintenance work

1

10

BMW Service

BMW Service 110,000 km

Carried out in accordance with
manufacturer's instructions

Odometer reading _____

Date, stamp, signature

BMW Service 130,000 km

Carried out in accordance with
manufacturer's instructions

Odometer reading _____

Date, stamp, signature

BMW Inspection 120,000 km

Carried out in accordance with
manufacturer's instructions

Odometer reading _____

Date, stamp, signature

BMW Inspection 140,000 km

Carried out in accordance with
manufacturer's instructions

Odometer reading _____

Date, stamp, signature

Confirmation of maintenance work

BMW Service 150,000 km

Carried out in accordance with
manufacturer's instructions

Odometer reading _____

Date, stamp, signature

BMW Service 170,000 km

Carried out in accordance with
manufacturer's instructions

Odometer reading _____

Date, stamp, signature

BMW Inspection 160,000 km

Carried out in accordance with
manufacturer's instructions

Odometer reading _____

Date, stamp, signature

BMW Inspection 180,000 km

Carried out in accordance with
manufacturer's instructions

Odometer reading _____

Date, stamp, signature

Confirmation of maintenance work

1

12

BMW Service

BMW Annual Service

Carried out in accordance with manufacturer's instructions

Brake fluid changed:

Without BMW Integral ABS annually

yes no

With BMW Integral ABS

Wheel circuit - annually

yes no

Control circuit - every 2 years

yes no

Clutch fluid changed:

every 2 years

yes no

Date, stamp, signature

BMW Annual Service

Carried out in accordance with manufacturer's instructions

Brake fluid changed:

Without BMW Integral ABS annually

yes no

With BMW Integral ABS

Wheel circuit - annually

yes no

Control circuit - every 2 years

yes no

Clutch fluid changed:

every 2 years

yes no

Date, stamp, signature

BMW Annual Service

Carried out in accordance with manufacturer's instructions

Brake fluid changed:

Without BMW Integral ABS annually

yes no

With BMW Integral ABS

Wheel circuit - annually

yes no

Control circuit - every 2 years

yes no

Clutch fluid changed:

every 2 years

yes no

Date, stamp, signature

BMW Annual Service

Carried out in accordance with manufacturer's instructions

Brake fluid changed:

Without BMW Integral ABS annually

yes no

With BMW Integral ABS

Wheel circuit - annually

yes no

Control circuit - every 2 years

yes no

Clutch fluid changed:

every 2 years

yes no

Date, stamp, signature

Confirmation of maintenance work

BMW Annual Service

Carried out in accordance with manufacturer's instructions

Brake fluid changed:

Without BMW Integral ABS annually

yes no

With BMW Integral ABS

Wheel circuit - annually

yes no

Control circuit - every 2 years

yes no

Clutch fluid changed:

every 2 years

yes no

Date, stamp, signature

BMW Annual Service

Carried out in accordance with manufacturer's instructions

Brake fluid changed:

Without BMW Integral ABS annually

yes no

With BMW Integral ABS

Wheel circuit - annually

yes no

Control circuit - every 2 years

yes no

Clutch fluid changed:

every 2 years

yes no

Date, stamp, signature

BMW Annual Service

Carried out in accordance with manufacturer's instructions

Brake fluid changed:

Without BMW Integral ABS annually

yes no

With BMW Integral ABS

Wheel circuit - annually

yes no

Control circuit - every 2 years

yes no

Clutch fluid changed:

every 2 years

yes no

Date, stamp, signature

BMW Annual Service

Carried out in accordance with manufacturer's instructions

Brake fluid changed:

Without BMW Integral ABS annually

yes no

With BMW Integral ABS

Wheel circuit - annually

yes no

Control circuit - every 2 years

yes no

Clutch fluid changed:

every 2 years

yes no

Date, stamp, signature

Confirmations of service work

Odometer renewed

Odometer reading is not total distance covered.

Odometer reading _____

Date, stamp, signature

Odometer renewed

Odometer reading is not total distance covered.

Odometer reading _____

Date, stamp, signature

Odometer renewed

Odometer reading is not total distance covered.

Odometer reading _____

Date, stamp, signature

Odometer renewed

Odometer reading is not total distance covered.

Odometer reading _____

Date, stamp, signature

Your motorcycle is equipped with Digital Motor Electronic (MOTRONIC) engine management and a high-power ignition system.



Warning:

When the engine is running or the ignition is switched on, do not touch electrically live components, terminals or wiring.

– Risk of fatal accident!

Work on the electrical system only when the circuit has been interrupted (switch off ignition and lights). For greater safety, disconnect and insulate the negative battery lead.

If you intend to perform the maintenance and general care work described in the following section yourself, you must possess the necessary knowledge of technical matters and mechanical skills.

Your motorcycle is built to high technological standards. Special tools and purpose-designed diagnosis and testing equipment, together with the appropriate knowledge, are needed to keep your motorcycle in optimum working order.

Your authorised BMW motorcycle dealer possesses the necessary technical know-how and employs company-trained staff.

He can guarantee that your motorcycle is always maintained in a fault-free technical condition.

Remember: the safety and reliability of your motorcycle are the most important considerations.

You should therefore not attempt any complex repair or maintenance tasks.

Keep to the specified Inspection and Service intervals.

BMW refuses to accept liability for damage or consequential damage due to repairs or service work carried out by other than BMW-authorised workshops.

Technical modifications



Warning:

The data stored in the MOTRONIC control unit is the result of extensive experimental and testing work.

Tampering with the MOTRONIC control unit represents an increased safety risk for the rider.



Note:

Manipulation of the MOTRONIC control unit voids the warranty.

Technical modifications are only permitted to a limited extent.

Whenever you are planning such modifications, comply with all the legal requirements. The motorcycle must not infringe your national road-vehicle construction and use regulations. Your authorised BMW motor-cycle dealer will gladly advise you on technical requirements, the manufacturer's recommendations and the overall benefit likely to be obtained.

Genuine BMW parts

For reasons of safety, use only genuine BMW parts and accessories.

Genuine BMW parts are identical with those fitted to your motorcycle as original equipment. BMW Motorrad guarantees against material defects and poor workmanship, but cannot accept any liability for spare parts or accessories of outside origin.

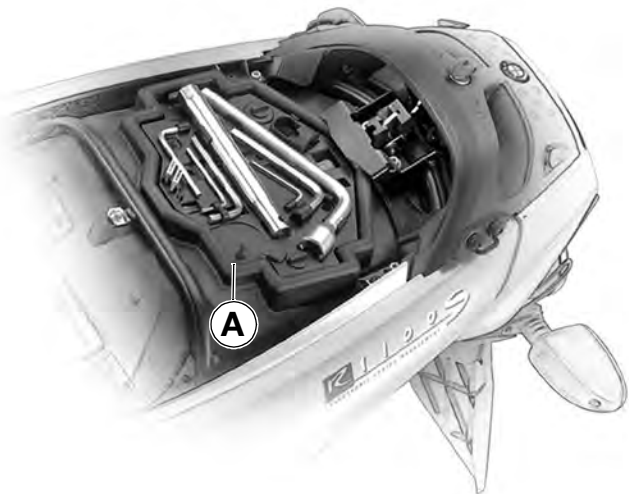

Location of toolkit

- Remove the seat
(➡ Rider's Manual, Chapter 1)
- The front of the toolbox **A** is then accessible



Warning:

The toolkit can become hot under extreme conditions.

w/f* = width across flats

**With main (centre) stand (optional extra)

Contents

Front of toolbox

- 4 Allen keys
 - w/f* 3 mm, 4 mm, 5 mm,
 - w/f* 6 mm
- 1 Torx T 45 wrench
- 1 puller for spark plug caps
- 1 spark plug wrench
- 1 wheel stud socket wrench**
- 1 flat fuse, 4 amps, pink
- 1 flat fuse, 15 amps, light blue

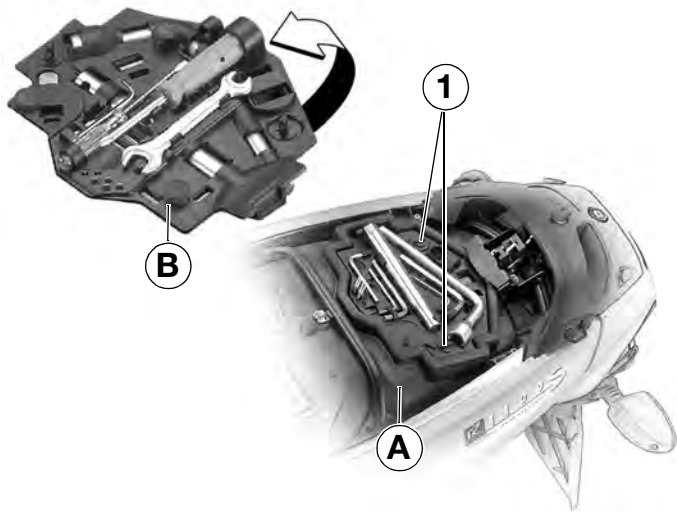

Contents

Rear of toolbox (B)

- Open the quick-release fasteners **1**
 - Take the toolbox out and turn it round (arrow)
- 1 screwdriver, large, reversible blade
- 1 Torx T 40 wrench
- 1 screwdriver, small
- 1 double open-ended spanner w/f* 10 x 13 mm



Warning:

The toolkit can become hot under extreme conditions.

w/f* = width across flats

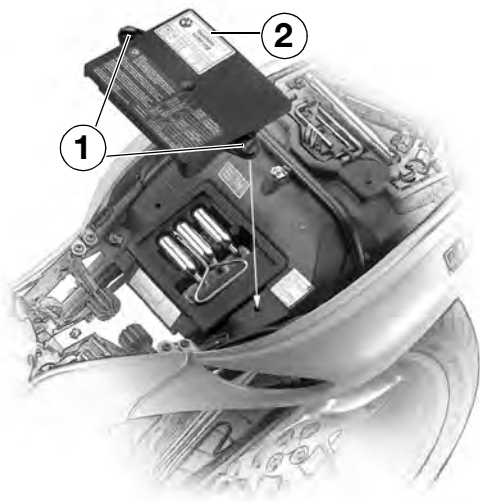

Tubeless tyre repair kit

Location of toolkit

- Remove the seat
(➔ Rider's Manual, Chapter 1)
- Open the quick-release fasteners **1**
- Remove cover **2** for tyre repair kit
- Motorcycle documents are then accessible
- The tyre repair kit is then accessible



Note:

Refer to accompanying description for repair procedure.



Warning:

Only repair tyre damage up to 4 mm (0.16 in) in diameter.
Max. permitted speed:
60 km/h (approx. 37 mph).
Max. permitted distance:
400 km (approx. 250 miles).
Always have the damaged tyre replaced.

Auxiliary stand

2

24

Maintenance and care

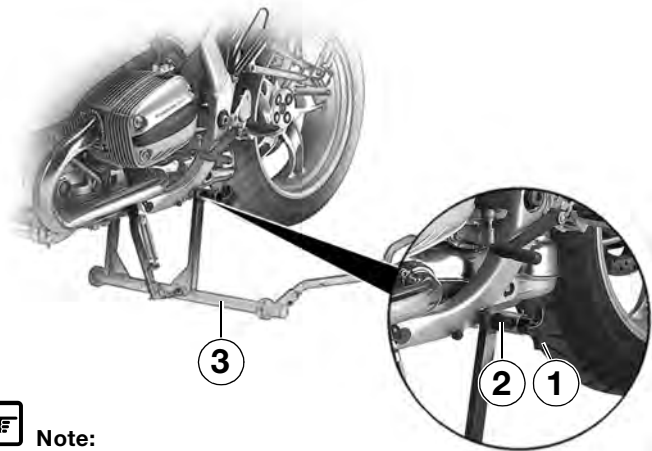

Note:

When removing a front or rear wheel, you are recommended to use the auxiliary stand, special tool No. 00 1 560, which is available from your BMW motorcycle dealer.

Attaching/removing the auxiliary stand



Caution:

Switch off the engine before installing the stand.

Make sure that there is a firm surface under the stand.

- Support the motorcycle on its side stand
- Place auxiliary stand **3** beneath the motorcycle
 - Knob **1** on the left-hand side of the motorcycle
- Pull out locking pin **2**
- Pull out knob **1** and secure it with locking pin **2**

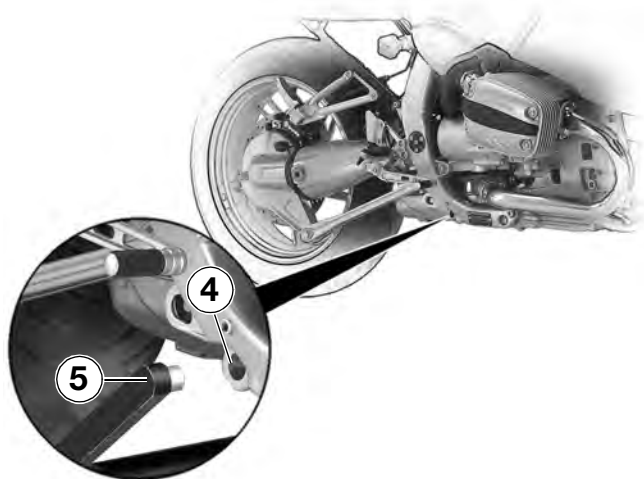

- Insert adapter **5** of auxiliary stand **3** through the motorcycle's right-hand bore **4** for the main (centre) stand
- Disengage locking pin **2** and insert the left-hand adapter into left-hand bore for the main stand
- Locking pin **2** must engage with an audible click
- Check that the auxiliary stand is secured firmly

Removing the auxiliary stand

- Before removing the stand, extend the side stand
- Removal of the auxiliary stand is the reverse of the installation procedure

Auxiliary stand

2

26

Maintenance and care

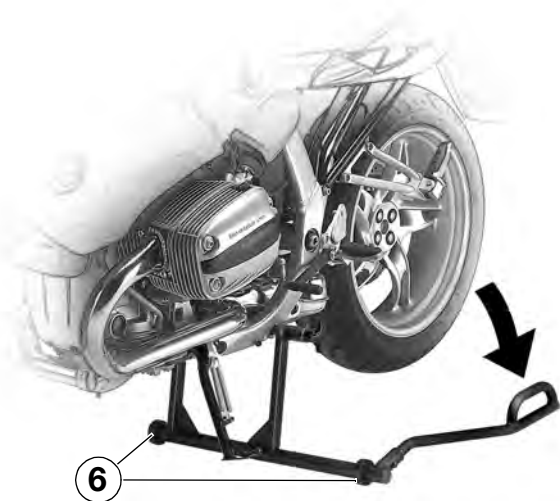

Placing motorcycle on auxiliary stand



Warning:

For safety reasons, never sit on the motorcycle when it is supported on its auxiliary stand.



Caution:

Make sure that there is a firm surface under the stand.

- Hold the left handlebar grip with the left hand
- Hold the handle of the auxiliary stand with the right hand
- Lift the motorcycle into the upright position and hold it in this position until both feet **6** of the stand are in contact with the ground
- Slowly press the stand handle down towards the ground (arrow)
- Check that the motorcycle is supported firmly



Lowering motorcycle from auxiliary stand



Warning:

The auxiliary stand must be removed before the motorcycle is ridden.

- Extend the side stand
- Hold the left handlebar grip with the left hand
- Hold the handle of the auxiliary stand with the right hand
- Pull the handle up slowly (arrow) until the weight is removed from the auxiliary stand
- Support the motorcycle on its side stand
- Remove the auxiliary stand

Troubleshooting chart

Malfunction: Engine does not start at all or is very difficult to start

Possible cause	Remedy	See ➡ Page
Key not turned in correct direction	Ignition key in ON position	Rider's Manual, ➡ 8, 9
Kill switch is off	Move kill switch to centre position	Rider's Manual ➡ 58
Side stand extended, gear selected	Select neutral or retract side stand and clutch lever	Rider's Manual ➡ 53
Gear engaged but clutch not disengaged	Select neutral or pull clutch lever	Rider's Manual ➡ 59
No fuel in tank	Add fuel	Rider's Manual ➡ 25
Fuel pump not working	Blown fuse 4	➡ 60
Incorrect operation of twistgrip	Operate correctly	Rider's Manual ➡ 61
Blocked air filter element	Renew	➡ 64
Defective spark plug	Renew	➡ 63
Spark plug/leads or caps wet	Blow out/dry with compressed air	
Insufficient battery charge	Recharge battery	➡ 67

**Note:**

It is advisable to have other faults – not described on pages 18...77 – attended to by a specialist workshop, preferably an authorised BMW motorcycle dealer.

**Note:**

More detailed technical information is available in the following publications:

- BMW Repair Manual
- BMW electrical circuit diagram brochure

Removing the front wheel

2

30

Maintenance and care



Caution:

When removing, avoid damage to brake pipes, brake discs, brake pads or the wheel rim (mask off with tape if necessary).



Keep dirt and moisture away from the wheel bearings.

Important for BMW Integral ABS*: do not damage the ABS sensor cable, toothed ring or sensor.



Note:

Mark the installed position on the tyre and ABS toothed ring; note also the direction of rotation arrow if it is marked on the tyre.

- On a firm, level surface, place the motorcycle on its main (centre) stand* (Rider's Manual  Chapter 2) or on the auxiliary stand ( 24-27)



Warning:

Apply weight to the rear of the motorcycle so that it cannot tip forward.

* Optional extra

Removing the front wheel

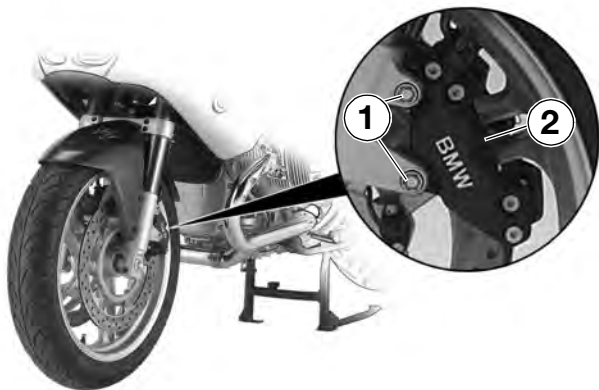

- Remove the securing screws **1** for the left and right brake calipers
- Tilt the brake calipers to force back the brake pads
- Carefully take off the left and right brake calipers **2**



Caution:

Do not scratch the rim when forcing back the brake pads or removing the calipers (apply masking tape if necessary).

To prevent damage to the brake caliper and possible difficulty when assembling: never apply the brake lever when the brake calipers have been removed.



Note:

Check the brake pads, (➔ 42) have them replaced if necessary.

Removing the front wheel

2

32

Maintenance and care



- Place a support under the motorcycle so that the front wheel can rotate freely



Warning:

Make sure that the motorcycle is standing firmly and cannot tip forwards or to either side



Note:

A hydraulic car jack or a scissor jack with a wooden board to protect the motorcycle's sump, is a suitable means of supporting the motorcycle.

Removing the front wheel

2

33

Maintenance and care

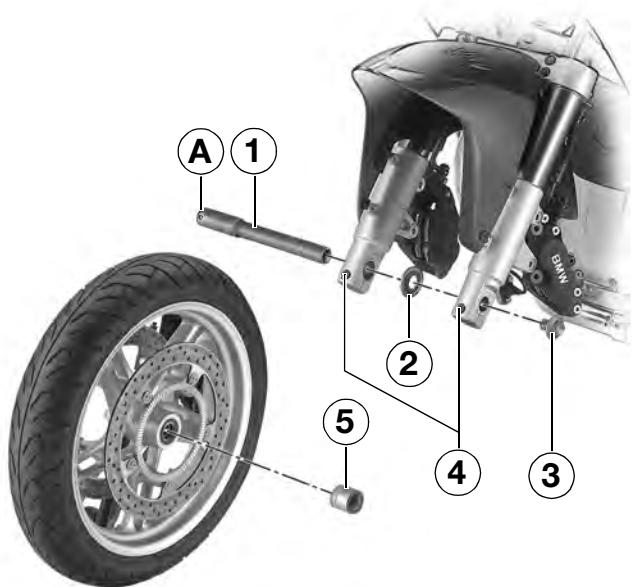

- Undo axle bolt **3**
- Slacken off axle clamp screws **4** at left and right
- Insert a suitable screwdriver through hole **A** in quick-release axle **1**
- Remove quick-release axle **1** to the right, turning it slightly at the same time

- Remove spacing bushing **5** and bearing cap **2**



Caution:

When setting down the front wheel, avoid damage to the brake discs and ABS toothed ring*.

- Roll the front wheel out forwards

* Optional extra

Installing the front wheel

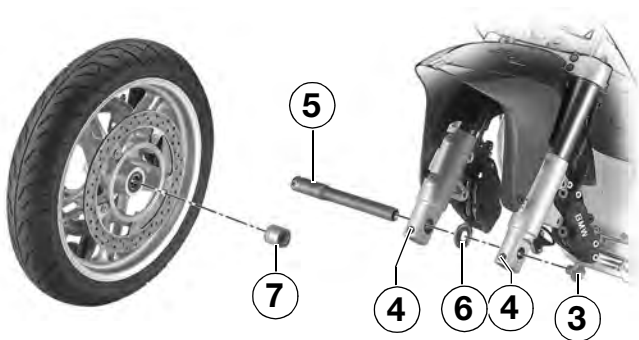

Caution:

Avoid damage to brake lines, discs and pads when installing. Keep dirt and moisture away from the wheel bearings. Important for BMW Integral ABS*: do not damage the ABS sensor cable, toothed ring or sensor.

- Roll the front wheel in between the fork legs
- Clean and insert spacing bushing **7** and bearing cap **6**
Looking forwards:
 - left: spacing bushing **7**
 - right: bearing cap **6**
- Clean the quick-release axle **5**, grease it and insert it from the right, turning it slightly at the same time
- Screw up axle bolt **3** hand-tight
- Screw up axle clamp bolts **4** hand-tight at left and right
- Compress the front fork firmly several times

* Optional extra

Installing the front wheel

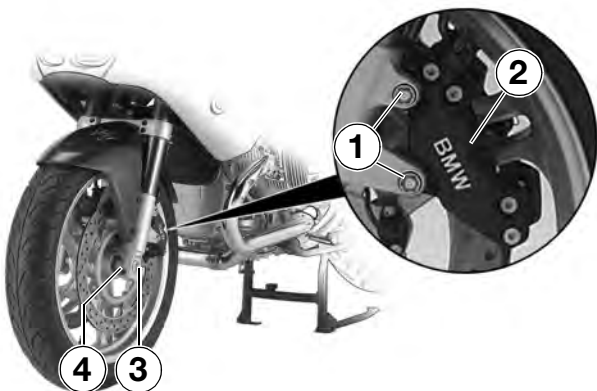

Warning:

Make sure that the motorcycle is standing firmly and cannot tip forwards or to either side

- Tighten axle bolt **3** to the specified torque
- Tighten axle clamp screws **4** at left and right to the specified torque
- Carefully push brake calipers **2** over the brake discs at left and right
- Insert two bolts **1** to secure each brake caliper **2** at left/right and tighten to the specified torque



Warning:

Motorcycle not equipped with BMW Integral ABS*: when assembly work has been completed, pull the brake lever firmly several times to check that the front brake is operating correctly.

BMW Integral ABS*: once assembly work on the brake calipers has been completed, the brake lever has to be operated after the ignition has been switched on and self-diagnosis completed, in order to ensure full operability.

* Optional extra

Installing the front wheel



2

36

Maintenance and care

- Remove the motorcycle from its main (centre) stand or the auxiliary stand (➔ 27)
- Detach the auxiliary stand (➔ 24)



Caution:

Always have the tightening torques checked by a specialist workshop, preferably an authorised BMW motorcycle dealer.



Tightening torque:

Axle bolt	30 Nm
Axle clamp screw	22 Nm
Brake caliper screw	30 Nm

Removing the rear wheel

2

37

Maintenance and care



Caution:

When removing, avoid damage to brake pipes, brake discs, brake pads or the wheel rim (mask off with tape if necessary).

Important for BMW Integral ABS*: do not damage the ABS sensor cable, toothed ring or sensor.



Warning:

The motorcycle must stand firmly, and not be able to tip forwards or to the side.

- On a firm, level surface, place the motorcycle on its main (centre) stand* (Rider's Manual ► Chapter 3) or on the auxiliary stand (► 24-27)
- Select first gear

* Optional extra

Removing the rear wheel

2

38

Maintenance and care

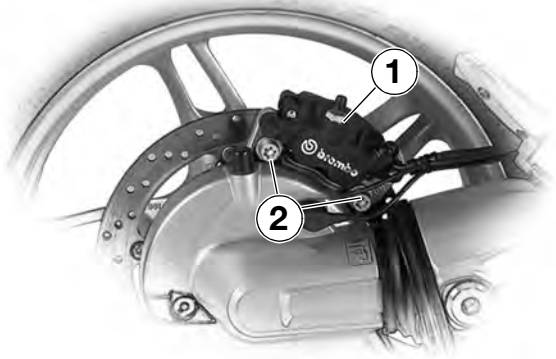

Caution:

Do not scratch the wheel when forcing back the brake pads or removing the caliper (apply masking tape if necessary).

To prevent damage to the brake caliper and possible difficulty when assembling: never operate the brake lever when the brake calipers have been removed.

- Remove screws **2** securing brake caliper **1**
- Force the brake pads in by tilting the caliper
- Carefully remove brake caliper **1**



Note:

Check brake pads, (→ 43), have them replaced if necessary.

Removing the rear wheel

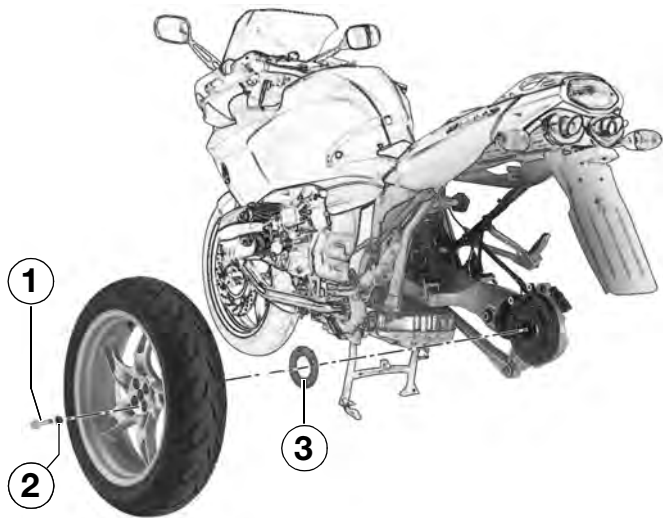

- Unscrew the four wheel studs **1** with taper rings **2**
- Lift the rear wheel off the centering spigot and take it out carefully

- Important for BMW Integral ABS* note spacing washer **3**



Caution:

Protect the wheel hub contact face against dust and dirt.

* With main (centre) stand (optional extra)

Installing the rear wheel

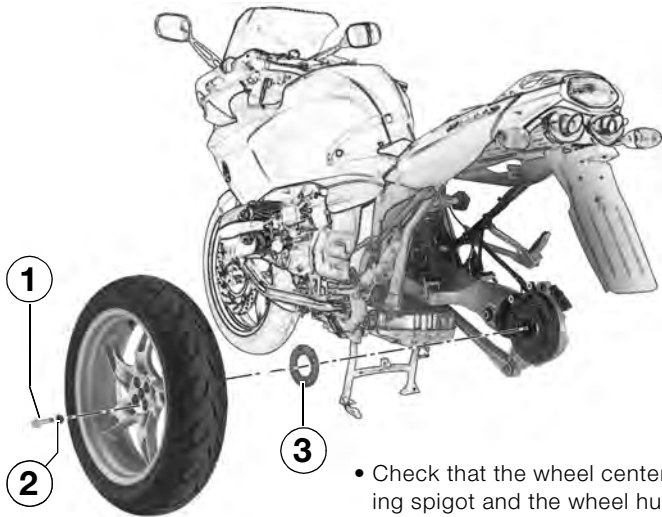

Caution:

Use only wheel studs with the same length code number.

Do not oil or grease the wheel studs.

Avoid damage to brake lines, brake disc, brake pads or the wheel when installing.

Important for BMW Integral ABS*: do not damage the ABS sensor cable, toothed ring or sensor.

- Check that the wheel centering spigot and the wheel hub contact face are clean and free from grease
- Important for BMW Integral ABS*, push spacing washer **3** on to the wheel centering spigot
- Insert the rear wheel in the centering spigot bore
- Screw in the four wheel studs **1** with taper rings **2** hand-tight, then tighten to the specified preload torque in diagonally opposite sequence
- Tighten the wheel studs **1** to final torque in diagonally opposite sequence

* Optional extra

Installing the rear wheel

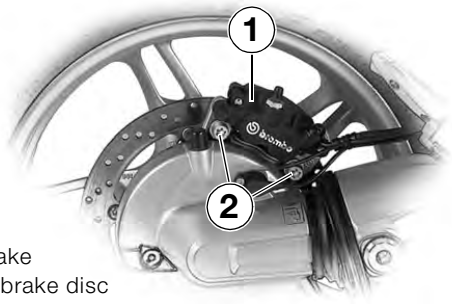

- Carefully place brake caliper **1** over the brake disc
- Tighten brake-caliper screws **2** to specified torque
- Remove the motorcycle from its main (centre) stand or the auxiliary stand (➔ 27)
- Detach the auxiliary stand (➔ 24)



Caution:

Always have the tightening torques checked by a specialist workshop, preferably an authorised BMW motorcycle dealer.



Tightening torque:

Preload torque	
Wheel studs	50 Nm
Tightening torque	
Wheel studs	105 Nm
Brake caliper screw	30 Nm



Warning:

Motorcycle not equipped with BMW Integral ABS: when assembly work has been completed, depress the brake pedal firmly several times to check that the rear brake is operating correctly.

BMW Integral ABS: once assembly work on the brake calipers has been completed, the brake lever has to be operated after the ignition has been switched on and self-diagnosis completed, in order to ensure full operability.

* Optional extra

Checking brake pads

2

42

Maintenance and care

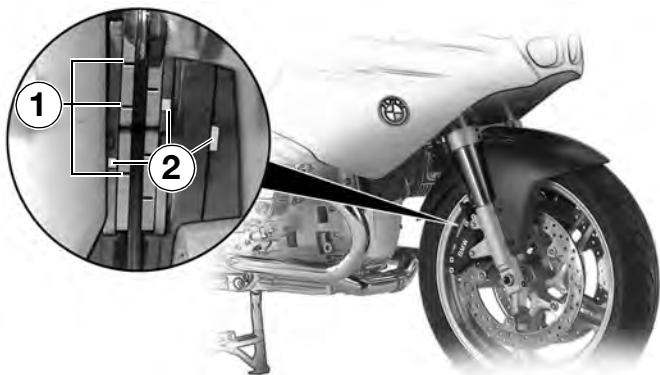

Front brake



Caution:

Have brake pads replaced before the minimum permitted thickness is reached.



Note:

For your safety, we recommend having work on the brake system performed by a specialist workshop, preferably an authorised BMW motorcycle dealer.

- Support the motorcycle on its side stand

- Visually inspect to ensure that both brake pads and the brake caliper bear have the same colour-code marks **2**
- Make a visual check on brake pad thickness

Minimum pad thickness:

Wear indicating mark 1 must be clearly visible on the pads.

– If the wear indicating mark is no longer clearly visible:

Have the brake pads changed by a specialist workshop, preferably an authorised BMW motorcycle dealer.



Rear brake



Caution:

Have brake pads replaced before the minimum permitted thickness is reached.



Note:

For your safety, we recommend having work on the brake system performed by a specialist workshop, preferably an authorised BMW motorcycle dealer.

- Visually check brake pad thickness
- **Minimum pad thickness: Make sure that the brake disc is not visible through bore 1 in the inner brake pad.**
- If the brake disc is visible through bore 1 in the inner brake pad:
Have the brake pads changed by a specialist workshop, preferably an authorised BMW motorcycle dealer.
- Make sure the ground is level and firm and lift the motorcycle onto its side stand

Removing the side panels

2

44

Maintenance and care

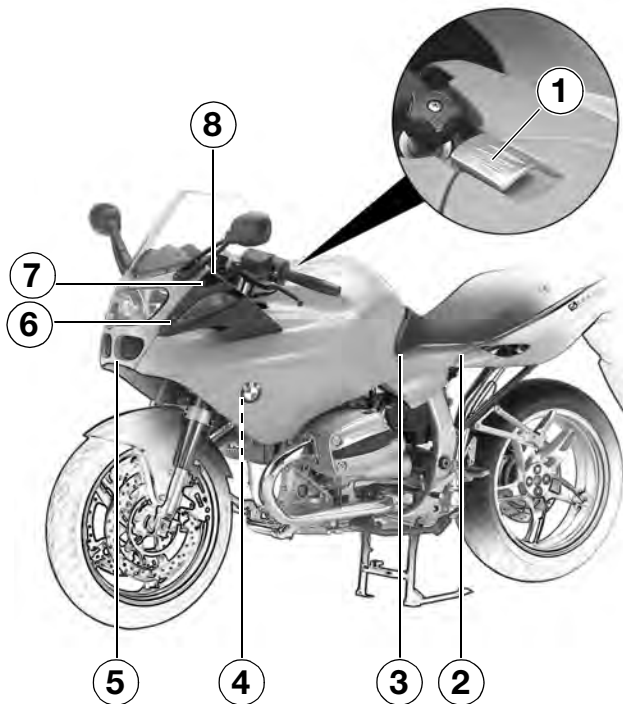

- Support the motorcycle on its side stand
- Removing/locking seat (Rider's Manual, Chapter 1)
- Disconnect turn indicator
- Unfasten quick-release catch **1**
- Open retaining screws **2** to **8**
- Carefully raise the side fairing
- Take off the left side panel and set it down



Warning:

Note that untreated aluminium surfaces form a natural oxide surface.

For reasons of strength, this protective layer must not be removed from the panel holder or fuel tank.

- Assembly is the reverse of the removal procedure

**Note:**

The right side panel is removed/installed in the same way.

Headlight beam setting

2

46

Maintenance and care



Warning:

Work on the electrical system only when the circuit has been interrupted (switch off ignition and lights). For greater safety, disconnect and insulate the negative battery lead.

When the engine is running or the ignition is switched on, do not touch electrically live components, terminals or wiring.

– Risk of fatal accident!

Headlight beam setting for riding on left/right

Your motorcycle is equipped with Digital Motor Electronic (MOTRONIC) engine management and a high-power ignition system.

- Support the motorcycle on its side stand
- Take off the left/right side panels (► 44)
- Disconnect the battery **negative** cable (-) (► 69)

Headlight beam setting

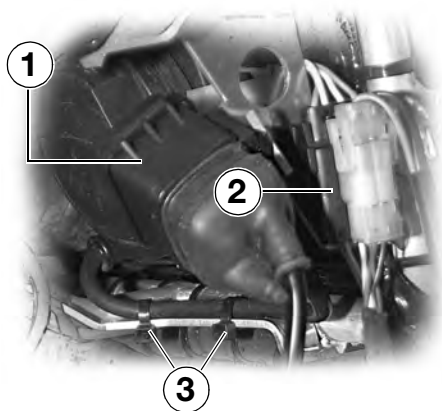

- Disconnect plug **2** next to right fuse box **1**



Warning:

Note that untreated aluminium surfaces form a natural oxide surface.

For reasons of strength, this protective layer must not be removed from the panel holder or fuel tank.



Caution:

Do not damage wires when releasing cable ties.

- Using a knife, carefully cut open cable ties **3** at the panel holder



Note:

If a cable tie is not available when installing, use adhesive tape until the next visit to the workshop.

Headlight beam setting

2

48

Maintenance and care

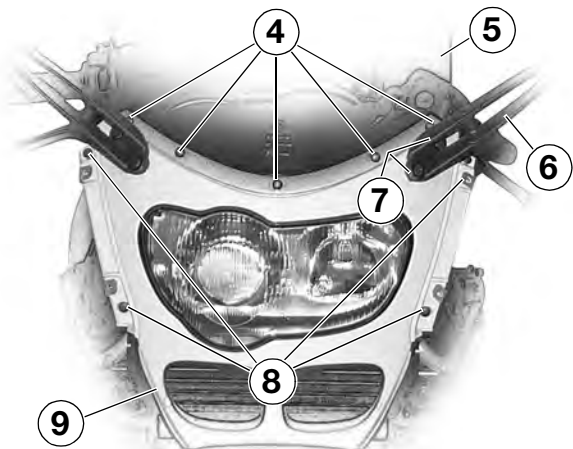

Caution:

Take care not to scratch the windscreen and front fairing during removal and installation.

- Take out retaining screws **4** and set windscreen **5** down carefully
- Take out retaining screws **7** and set down the left/right mirrors **6** carefully
- Remove the screws **8** holding the front panel **9**
- Pull the front panel **9** with the headlight carefully forwards out of the panel holder

Headlight beam setting

2

49

Maintenance and care

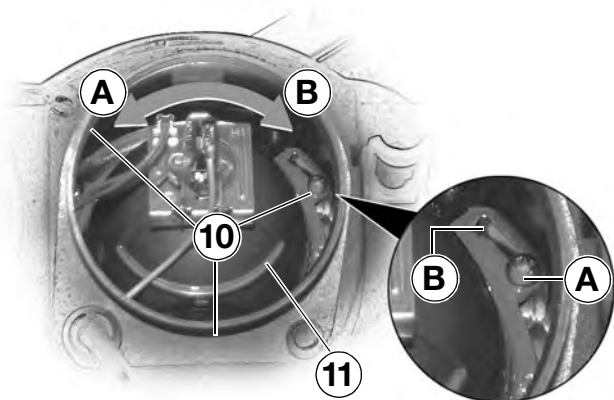

- Take off the right rubber cap



Caution:

Avoid damaging the front fairing and headlight glass during adjustment work.

- Loosen 3 screws **10** for headlight bezel **11** by about 4 turns
 - Lift the headlight trim **11** out of its retainer and turn it to position **B** (arrow) until the headlight bezel is heard to engage
- Position **A**: riding on right
 - Position **B**: riding on left
 - 3 screws **10** for headlight trim **11**
 - Installation is the reverse of the removal procedure



Caution:

Take care not to overtighten the securing screws for the wind-screen. (Max. 2 Nm)

Notes on changing bulbs

2

50

Maintenance and care

Your motorcycle is equipped with Digital Motor Electronic (MOTRONIC) engine management and a high-power ignition system.



Warning:

Work on the electrical system only when the circuit has been interrupted (switch off ignition and lights). For greater safety, disconnect and insulate the negative battery lead. When the engine is running or the ignition is switched on, do not touch electrically live components, terminals or wiring.
– Risk of fatal accident!



Caution:

Your vehicle has a high-beam/low-beam bulb, a brake-light/rear-light bulb, a parking-light bulb and a bulb for the number-plate light.

If any of these bulbs fail, you may have problems in seeing and being seen.

You should therefore always carry spare bulbs on the motorcycle.



Note:

Avoid touching the glass of new bulbs with the fingers. Use a clean, dry cloth to hold the bulbs when inserting them. Dirt deposits, in particular oil and grease, interfere with heat radiation from the bulb. This leads to overheating and shortens the bulb's operating life.



Parking light



Caution:

Switch off the ignition before changing a bulb.



Note:

Do not touch the glass of new bulbs with the fingers. Use a clean, dry cloth to hold the bulbs when inserting them.

- Make sure the ground is level and firm and lift the motorcycle onto its side stand
- Turn the handlebars to the left
- Take off the left rubber cover
- Release the bulb holder **1** by turning to the right, and pull it out
- Remove the bulb **2** from the bulb holder
- Installation is the reverse of the removal procedure; when inserted and turned to the left the bulb holder **1** must be heard to engage in its mounting

– Parking light bulb: **12 V 5 W**

Changing bulbs

2

52

Maintenance and care

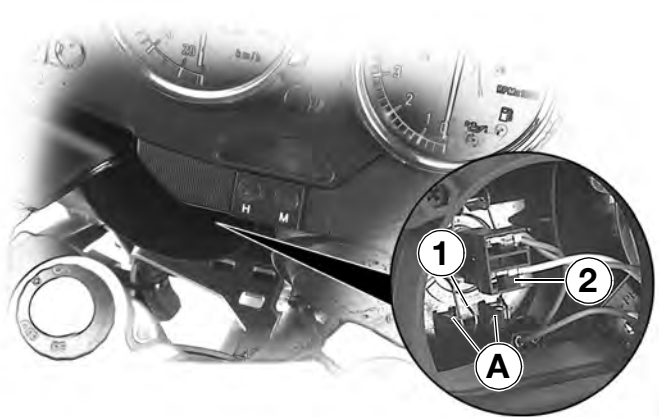

High (main) beam



Caution:

Switch off the ignition before changing a bulb.



Note:

Do not touch the glass of new bulbs with the fingers.
Use a clean, dry cloth to hold the bulbs when inserting them.

- Make sure the ground is level and firm and lift the motor-cycle onto its side stand
- Turn the handlebars to the left

Removing:

- Take off the left rubber cover **3**
 - Detach plug housing **2** from bulb connector
 - Release spring clips **1** from retainer **A** at left and right and swing clips upwards
 - Remove the H7 bulb
- High (main) beam:
H7 12 V 55 W

Changing bulbs

2

53

Maintenance and care

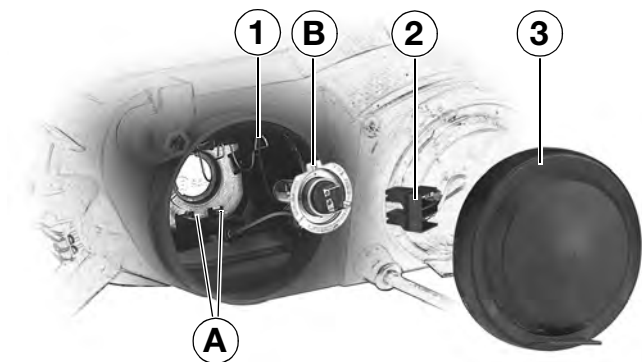

Inserting:

– High (main) beam:

H7 12 V 55 W

- Insert the new H7 bulb, noting groove **B**:
- Groove **B** must face up
- Engage the left and right spring clips **1** at the bottom in the retainer **A**
- Attach plug housing **2** to the bulb connector
- Attach left rubber cover **3**

Changing bulbs

2

54

Maintenance and care

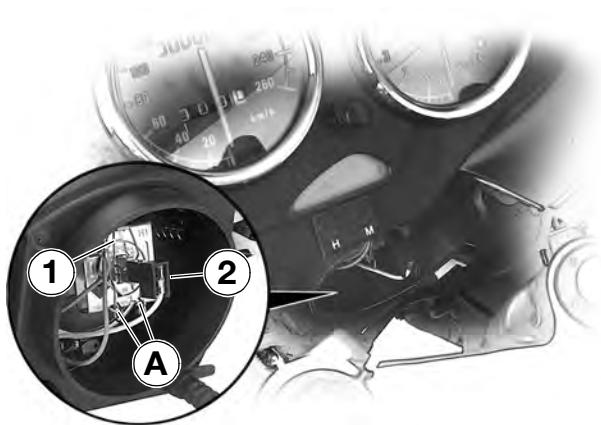

Low-beam headlight



Caution:

Switch off the ignition before changing a bulb.



Note:

Do not touch the glass of new bulbs with the fingers.
Use a clean, dry cloth to hold the bulbs when inserting them.

- Turn the handlebars to the right

Removing:

- Take off the right rubber cover **3**
- Detach plug housing **2** from bulb connector
- Release spring clips **1** from retainer **A** at left and right and swing clips upwards
- Remove the H1 bulb
 - Low (dipped) beam:
H1 12 V 55 W

Changing bulbs

2

55

Maintenance and care

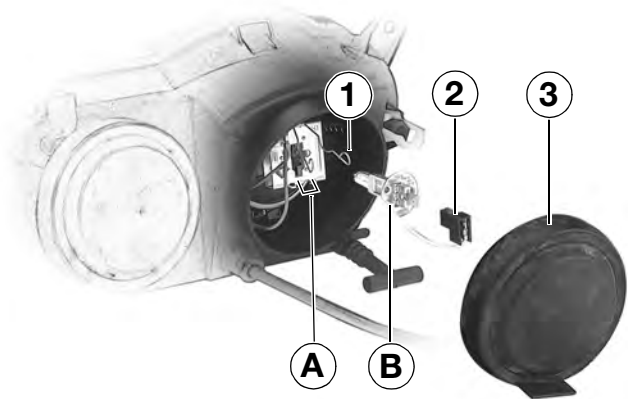

Inserting:

– Low (dipped) beam:

H1 12 V 55 W

- Insert the new H1 bulb, noting the bevelled surface **B**:
- The bevelled surface **B** must face the bottom left
- Engage the left and right spring clips **1** at the bottom in the retainer **A**
- Attach plug housing **2** to the bulb connector
- Attach right rubber cover **3**

Changing bulbs

2

56

Maintenance and care

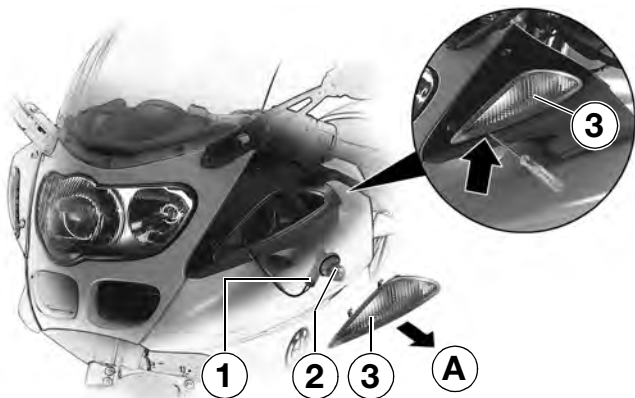

Front turn indicators



Caution:

Switch off the ignition before changing a bulb.



Note:

Do not touch the glass of new bulbs with the fingers. Use a clean, dry cloth to hold the bulbs when inserting them.

- Make sure the ground is level and firm and lift the motor-cycle onto its side stand
- Insert the blade of a small screwdriver into the groove (arrow) in turn-indicator lens **3** and gently press the lens up
- Pull turn-indicator lens **3** to one side (arrow **A**) until it is clear of the fairing
- Hold the flashing turn indicator **3** and release the bulb holder **1** by turning it to the left
- Hold the bulb holder **1** and release the bulb **2** by turning to the left
- Remove the bulb
- Installation is the reverse of the removal procedure
- Turn indicator bulb: **12 V 21 W**

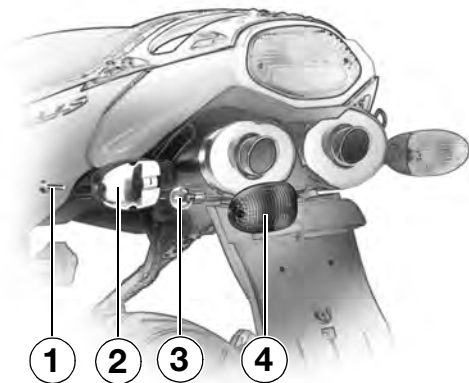

Rear turn indicators



Caution:

Switch off the ignition before changing a bulb.



Note:

Do not touch the glass of new bulbs with the fingers. Use a clean, dry cloth to hold the bulbs when inserting them.

- Make sure the ground is level and firm and lift the motor-cycle onto its side stand
 - Take out retaining screw **1**
 - Take off the flashing turn indicator glass **4**
 - Hold bulb housing **2**, press the bulb **3** in and turn it to the left to release it
 - Remove the bulb
 - Installation is the reverse of the removal procedure
- Turn indicator bulb:
12 V 21 W

Changing bulbs

2

58

Maintenance and care

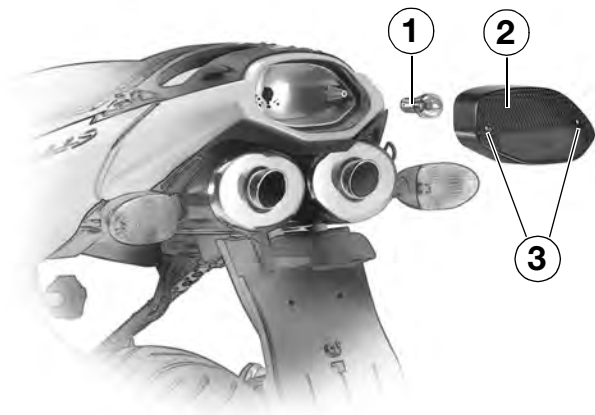

Rear/brake light



Caution:

Switch off the ignition before changing a bulb.



Note:

Do not touch the glass of new bulbs with the fingers.
Use a clean, dry cloth to hold the bulbs when inserting them.

- Make sure the ground is level and firm and lift the motorcycle onto its side stand
 - Remove two screws **3**
 - Pull rear light glass **2** out rearwards
 - Press bulb **1** forwards and turn to the left to release
 - Remove the bulb
 - Installation is the reverse of the removal procedure
- Brake/rear light bulb:
12 V 21/5 W

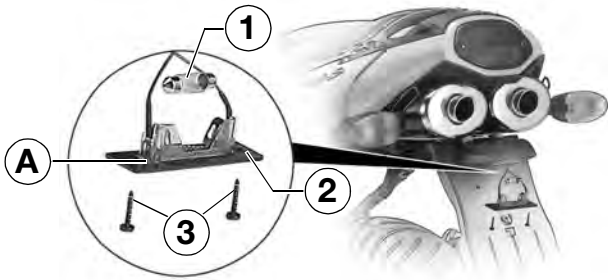

Number plate light



Caution:

Switch off the ignition before changing a bulb.



Note:

Do not touch the glass of new bulbs with the fingers. Use a clean, dry cloth to hold the bulbs when inserting them.

- Make sure the ground is level and firm and lift the motor-cycle onto its side stand

Removing:

- Remove two screws **3**
- Remove number plate light cover **2** downwards
- Press back the spring wire clip and remove the bulb **1**

Inserting:

- Number plate light bulb:
12 V 5 W Soffite
- Place the bulb **1** in the two spring clips
- Insert number plate light cover **2**, noting pin **A**
- Tighten two screws **3** without using force

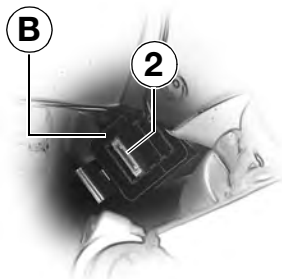
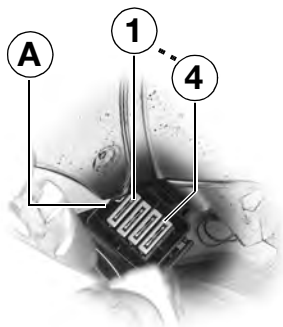

Equipment connected to fuses

A Left fuse box

- 1 Instrument cluster, controller fuel warning lamp, or indicator damping, brake light (without BMW Integral ABS)4 A
- 2 Rear light, parking light, number plate light4 A
- 3 Instrument cluster, horn, power socket15 A
- 4 MOTRONIC, pump15 A

B Right fuse box (for optional extras)

- 1 not in use
- 2 Heated handlebar grips4 A
- 3 not in use
- 4 not in use



Caution:

Before changing a fuse, switch off the ignition.

Never attempt to repair a blown fuse – risk of fire!

Always carry a set of spare fuses (➔ 21).

Use only fuses of the specified rating and type.

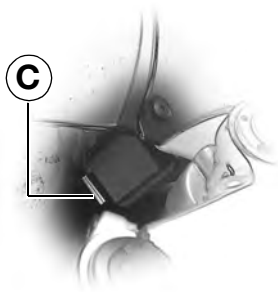

Replacing fuses

- Make sure the ground is level and firm and lift the motorcycle onto its side stand
- Take off the left side panel (➡ 44)



Note:

The right side panel only needs to be removed when changing fuses for optional extras.

- Press retaining clip **C** to one side and swing the fuse box cover open
- Pull the blown fuse out of its holder
- Insert a new fuse of the correct rating
- Close the fuse box lid
- Attach the left side panel (➡ 44)



Note:

It is advisable to have the motorcycle checked by a specialist workshop, preferably an authorised BMW motorcycle dealer if fuses blow frequently.

Spark plugs

2

62

Maintenance and care

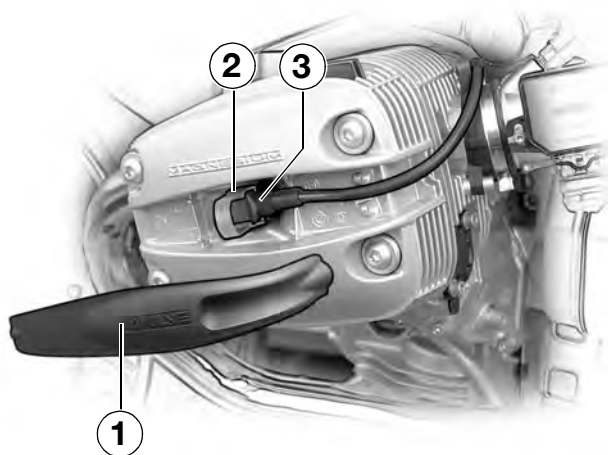

Warning:

Work on the electrical system only when the circuit has been interrupted (switch off ignition and lights). For greater safety, disconnect and insulate the negative battery lead. When the engine is running or the ignition is switched on, do not touch electrically live components, terminals or wiring.
– Risk of fatal accident!

Your motorcycle is equipped with Digital Motor Electronic (MOTRONIC) engine management and a high-power ignition system.

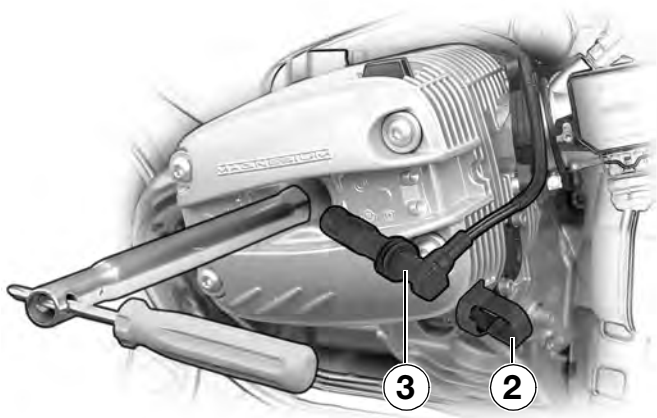

Removing spark plugs

- Remove spark plug cover **1**
- Use puller **2** to disconnect spark plug cap **3**.
- Use spark plug wrench and screwdriver to remove the spark plug.
- Installation is the reverse of the removal procedure



Note:

Engage the spark plug cover at the rear first, then engage the front of the cover.

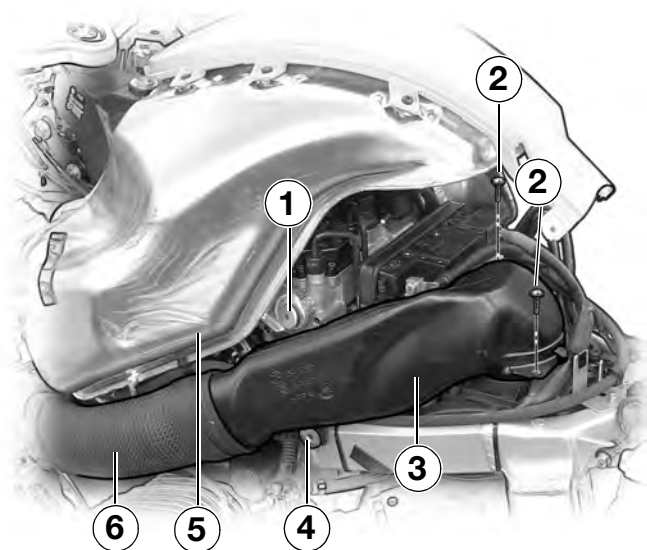

Replacing air filter element



Warning:

Avoid damage to fuel tank, wiring and hoses during removal work.

- Make sure the ground is level and firm and lift the motorcycle onto its side stand
- Remove left and right side trim panels (➔ 44)
- Disconnect flexible intake-air duct **6**
- Remove securing screw **4** from intake air pipe **3**
- Release the fuel tank fasteners **1** at left/right
- Raise the fuel tank **5** slightly with great care
- Remove securing screws **2** on left and right from intake air pipe **3**
- Disconnect intake air pipe **3** from air filter cover.

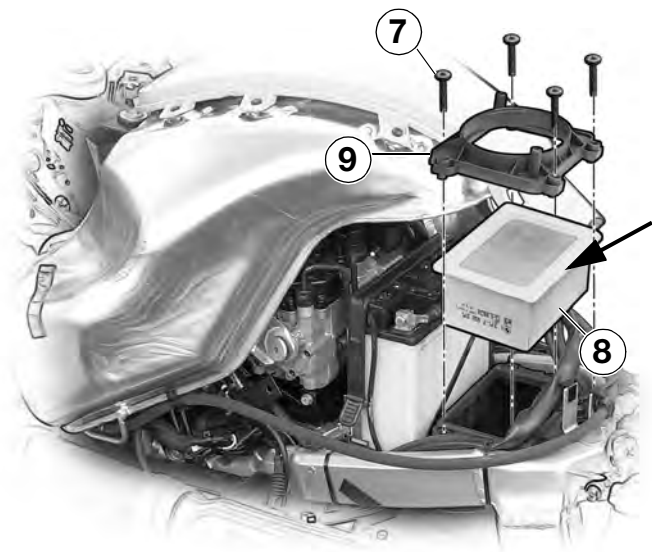

- Remove four securing screws **7** on left and right from air filter cover **9**
- Remove air filter cover **9**
- Remove old filter element **8** from the housing
- Place the new filter element in position inside the housing



Note:

The white paper seal (arrow) must be at the top

Further installation is the reverse of the removal procedure.

Battery safety instructions

2

66

Maintenance and care

CALIFORNIA PROPOSITION 65 WARNING



Warning:

Battery posts, terminals, and related accessories contain lead and lead compounds. Wash hands after handling.



Warning:

Battery acid is highly caustic. It must not contact the eyes, face hands, clothing or the motorcycle's paintwork. **KEEP IT OUT OF REACH OF CHILDREN!**

Never create sparks or bring a naked flame or a glowing cigarette near the battery. Batteries generate explosive gases.

Charge batteries only in well-ventilated areas. The cell plugs must be opened when recharging the battery.



Warning:

For all work involving the battery, protective goggles and gloves should be worn.

If anyone comes into contact with battery acid or is exposed to toxic fumes from the battery, have them examined by a physician without delay.

Before the victim can be seen by the physician, take the following first aid measures:

- Contact with skin: wash off with plenty of clean water.
- Acid swallowed: victim must drink plenty of water or milk (into which a raw egg should be stirred). Do not cause the victim to vomit.
- Eyes attacked by battery acid or fumes from battery: Rinse the eyes out several times with plenty of clean water. The eyelid should be held open while doing so.
- Thoroughly rinse clothing wetted by battery acid immediately with water.

If the motorcycle is out of use for a lengthy period:

- Check battery acid level
- Store the battery in a cool, dry place
- Trickle-charge the battery from time to time during the storage period
- The battery can be recharged with the BMW battery trickle charger by way of the power socket*.
- Recharge the battery before the motorcycle is laid up out of use and when it is restored to use. Comply with the charging instructions.
- In case of doubt, ask your authorised BMW motorcycle dealer to prepare the motorcycle for laying up and to carry out the necessary battery maintenance and storage



Caution:

Correct maintenance, recharging and storage will prolong the life of the battery and are essential if warranty claims are to be considered.

* Optional extras

Battery maintenance instructions

2

68

Maintenance and care



Checking battery acid level

- Check the battery acid level every three months, or more frequently if the outside temperature is high
- Check the acid level at the **MIN/MAX** marks
- Add distilled water only up to the **MAX** mark



Note:

Top up only with distilled water, not acid.

Use a suitable coin to unscrew and tighten the cell plugs.

Starting aids



Warning:

The motorcycle must not be jump-started by way of the power socket*.

- **Risk of fire!**
- **Push-start the motorcycle only when the engine is cold.**

The wires leading to the power socket are not rated for jump-starting the engine.

* Optional extras

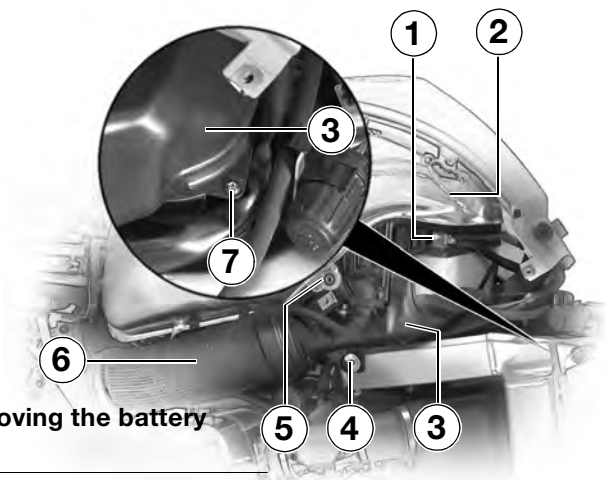

Removing the battery



Warning:

Avoid damage to fuel tank, wiring and hoses during removal work.

Before disconnecting the battery, switch off the ignition.

To avoid short-circuits:

- Disconnect the **negative** battery lead (-) **1** first,
 - then the **positive** battery lead (+) **11**.
-
- Make sure the ground is level and firm and lift the motor-cycle onto its side stand
 - Remove left and right side trim panels (➡ 44)

- Disconnect flexible intake-air duct **6**
- Remove securing screw **4** from intake air pipe **3**
- Release the fuel tank fastening **5** at left/right
- Raise the fuel tank **2** slightly with great care
- Remove securing screws **7** on left and right from intake air pipe **3**
- Remove air intake pipe **3**
- Disconnect the **negative** lead (-) **1** from the battery

Battery

2

70

Maintenance and care

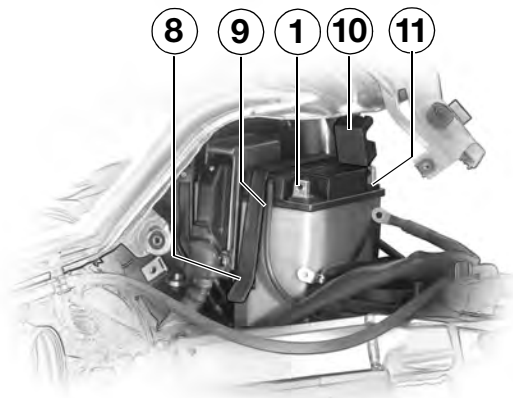

Warning:

Note that untreated aluminium surfaces form a natural oxide surface.

For strength reasons, this protective layer must not be removed from the fuel tank.

- Using a screwdriver, lever up the protective cap **10** over the positive battery pole
- Disconnect the **positive** lead (+) **11** from the battery
- Take off the battery vent hose **9**
- Release battery retaining strap **8**
- Raise the fuel tank slightly with great care
- Raise the battery, pull it out to the left and keep it in a horizontal position to avoid spilling acid
- Take out the battery

Installing the battery

- Grease the battery posts
- Make sure that the battery breather tube **9** is not kinked or blocked.
- Installation is the reverse of the removal procedure



Warning:

Before connecting the battery, switch off the ignition.

To avoid short-circuits:

- **Connect positive battery lead (+) 11 first**
- **Close the protective cap 10 for the positive battery pole**
- **Never install the battery without the protective cap**
- **Connect negative battery lead (-) 1**
- **Avoid damage to fuel tank, wiring and hoses when installing.**



Note:

Disconnecting the battery deletes all entries (e.g. faults, settings) stored in the Motronic control unit's memory. Loss of settings can temporarily impair the operating characteristics when the engine is re-started.

- Switch on the ignition
- Fully open the throttle once or twice
- The Motronic registers the throttle-valve positions

Cleaning/care

2

72

Maintenance and care



Note:

Regular cleaning, using the correct methods, is an important factor in maintaining the value of your motorcycle.

It also ensures that safety-relevant parts remain in full working order.



Warning:

Note that untreated aluminium surfaces form a natural oxide surface.

For reasons of strength, this protective layer must not be removed from the panel holder or fuel tank.



Caution:

Avoid damage to rubber or plastic parts caused by aggressive or penetrating cleaning agents or solvents.

Do not use a steam jet or high-pressure cleaning equipment. High water pressure can damage seals, the hydraulic brake system or the complete electrical system.



Washing the motorcycle

- Make sure the ground is level and firm and lift the motorcycle onto its side stand
- Clean the wheels, engine, gearbox and swinging arm with a mild detergent, following its manufacturer's instructions
- Thoroughly dry all wet surfaces
- Clean fairing elements only with cleaning and care products from the BMW Cleaning and Care Set
- Do not use solvents or cleaning products on the instrument cluster, switches or windscreen
- Remove tar splashes only with an approved product – rinse thoroughly with water afterwards.
- Clean flies and other insects off the fork stanchions
- Treat painted and chromed parts regularly with suitable care products



Warning:

After cleaning or before starting a journey, always test the brakes.

Removing road salt

- When the journey is over, wash the motorcycle immediately with cold water



Note:

Do not use warm water – this worsens the effect of the salt.

- Dry the motorcycle thoroughly.
- Apply a wax-based corrosion-proofing product to chrome-plated parts
- Coat/polish fairing elements after cleaning and drying with a recommended wax



Warning:

After cleaning or before starting a journey, always test the brakes.



Cleaning the windscreen



Caution:

Do not use cleansers. Fuel or chemical solvents attack the windscreen material.



Note:

Soften stubborn dirt or insects by soaking with a wet kitchen tissue.

- Remove dirt and dead insects with a soft sponge and plenty of water



Care of chromed parts



Note:

Treat chromed parts regularly with suitable care products.

- Apply a wax-based corrosion-proofing product to chrome-plated parts

Care of exhaust silencer

- Changes in the appearance of the exhaust system (these may be unavoidable for operating or environmental reasons) should be treated with "Metal Polish" from the Autosol company, BMW Order No. 82 14 9 400 890

Touching up damage

- Minor damage caused by stones striking the painted surface can be touched up with a BMW touch-up pencil of the correct colour



Caution:

Comply with the manufacturer's working instructions and safety precautions.



Note:

Have severe damage repaired by a specialist workshop, preferably your authorised BMW motorcycle dealer.

Laying up the motorcycle



Laying up

- Clean the motorcycle (➡ 72-75)
- Remove the battery (➡ 66-71), note the relevant maintenance instructions (➡ 66-68)
- Spray the brake and clutch lever pivots and the side stand pivots with a suitable lubricant
- Coat bright metal/chrome-plated parts with an acid-free grease (e.g. Vaseline)
- Park the motorcycle out of use in a dry place
- Place a support material under the engine so that neither wheel is carrying any weight. If necessary, install the auxiliary stand (➡ 26)
- When placing the support material in position, avoid damage to the exhaust pipes.



Note:

Before laying the vehicle up out of use have the engine oil and the oil filter element changed by a specialist workshop, preferably your authorised BMW motorcycle dealer.

It is always a good idea to combine the preparations for a lay-up and the post lay-up work with a service check or inspection by a specialist workshop, preferably your authorised BMW motorcycle dealer.



Restoring to use

- If necessary, remove protective wax coating
- Clean the motorcycle (➡ 72)
- Install a charged battery (➡ 71)
- Apply the correct grease to the battery terminals
- Perform all safety checks (Rider's Manual ➡ Chapter 2)
- Check the brakes (Rider's Manual ➡ Chapter 2)
- Check/correct tyre pressures (Rider's Manual ➡ Chapter 2)

Engine

Type Air-cooled flat-twin ("Boxer") with additional oil cooling in the exhaust valve areas and a single side-mounted, chain-driven camshaft on each side, operating 4 valves per cylinder by means of tappets and short pushrods; wet sump lubrication.

Displacement 1,085 cc

Max. output to DIN 70 020

72 kW

- at engine speed 7,500 rpm

Max. torque 97 Nm

- at engine speed 5,750 rpm

Permissible engine speeds

maximum 8,210 rpm

idle speed 1,100 +/- 50 rpm

Bore/stroke 99/70.5 mm
(3.90/2.78 in)

Compression ratio 11.3 : 1

Fuel consumption to ISO 7118

- at steady 90 km/h (56 mph) 4.3 l/100 km
(65.70 Imp. miles/gal)

- at steady 120 km/h (75 mph) 5.2 l/100 km
(54.32 Imp. miles/gal)

Mixture preparation Motronic MA 2.4

Maximum oil consumption 1.0 l/1,000 km
(1.41 Imp. pint/500 miles)

Clutch	Single dry plate with over-centre action diaphragm spring and starter ring gear, attached to crankshaft. Hydraulic operation.
Clutch plate diameter	165 mm (6.5 in)
Gearbox	6-speed with claw shift and integral torsional vibration damper
Gear ratios	1 st gear = 3.863 2 nd gear = 3.022 3 rd gear = 2.393 4 th gear = 1.961 5 th gear = 1.700 6 th gear = 1.511
Secondary drive from gearbox to rear wheel	By shaft protected within hollow swinging arm of Paralever rear suspension, with integral torsional vibration damper and two universal joints.
Final drive	Crown wheel and pinion with Palloid teeth, running in anti-friction bearings; rear wheel directly flange-mounted to rear of crown wheel.
Final drive ratio	1 : 2.75

Frame and suspension

3

80

Technical data

Frame	Three-part frame: cast aluminium front frame, aluminium main frame with load-bearing engine/gearbox unit, and tubular-steel rear section. The main frame and the rear frame are bolted together.
Location of type plate and frame number	Bottom right of main frame
	US/Canada models only: Fuel tank, right
Front brake	Hydraulically operated twin disc brake with 4-piston fixed calipers, angular wear compensation and floating stainless-steel brake discs. Sintered metal brake pads Note the colour-code marks (► 42)
Rear brake	Hydraulic disc brake with 2-piston floating caliper and stainless steel disc. Semi-metal brake-pad linings
Brake system*	BMW Integral ABS*, partially integral

*Optional extra

Frame and suspension

Wheel location

Front	Light-touch wheel guidance (Telelever) with central suspension strut.
Rear	Cast aluminium single swinging arm with additional torque reaction strut to compensate for shaft drive effects (Paralever); central suspension strut.

Steering lock angle

2 x 31°

Front wheel castor

- in normal-load position 100 mm (3.94 in)

Front suspension

Steel leading link, central suspension strut with coil spring and single-tube shock absorber. Continuously variable rebound damping setting.

Spring compression 55 mm (2.17 in)

Spring extension 55 mm (2.17 in)

Total travel 110 mm (4.33 in)

Fixed tube diameter 35 mm (1.38 in)

Frame and suspension

Rear suspension

Central suspension strut with coil spring and single-tube shock absorber.

Hydraulic spring preload adjustment.

Continuously variable rebound damping setting.

Spring compression	95 mm (3.74 in)
Spring extension	35 mm (1.38 in)
Total travel	130 mm (5.12 in)
Swinging arm length	520 mm (20.47 in)

Tyre pressures (with tyres cold)

One-up	front	rear
	2.20 bar (14.5 psi)	2.50 bar (36.3 psi)
Two-up	front	rear
	2.50 bar (36.3 psi)	2.70 bar (39.2 psi)
Two-up with luggage	front	rear
	2.50 bar (36.3 psi)	2.90 bar (42.0 psi)

Frame and suspension

Wheels and tyres

BMW cast aluminium wheels,
5 twin-spoke styling,
low aspect-ratio tyres

Front wheel

With inclined rim shoulder and
double hump

Size and designation

3.50 x 17 MT H2

Tyre size and designation

120/70 ZR 17
TUBELESS

Rear wheel

With inclined rim shoulder and
double hump

Size and designation

5.00 x 17 MT H2

Optional extras

5.50 x 17 MT H2

Tyre size and designation

170/60 ZR 17
TUBELESS

Optional extras

180/55 ZR 17
TUBELESS

Recommended minimum tyre tread depth

Front wheel

2 mm (0.08 in)

Rear wheel

3 mm (0.12 in)



Warning:

**Always comply with legal
requirements concerning the
minimum permissible tyre tread
depth.**

Fluids and lubricants

Engine oil

Brand-name HD oil, API classification SF, SG or SH; the suffixes CD or CE are permitted; or brand-name HD oil of CCMC classification G4 or G5; the suffix PD2 is permitted.

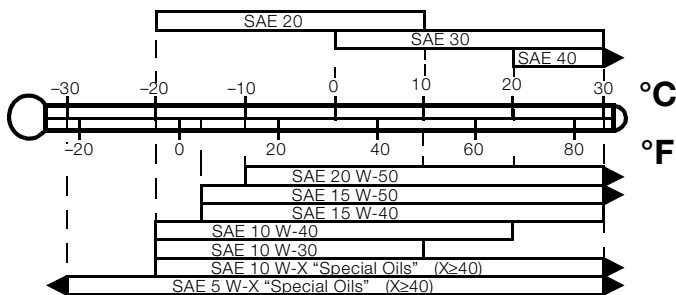

The viscosity class depends on outside temperatures.

Temperatures above or below the limits quoted for the individual SAE classifications are permitted for brief periods only.

Special Oils are approved individually by BMW AG and available from your authorised BMW motorcycle dealer.

All engine oils supplied by BMW are subjected to regular BMW quality assurance checks.

BMW does not approve the use of any upper-cylinder lubricants or similar oil additives.

Engine oil capacity

without filter replacement 3.50 l (6.2 Imp. pints)

if filter is renewed 3.75 l (6.6 Imp. pints)

Fluids and lubricants

Gearbox oil Brand-name hypoid gear oil,
API class GL 5

Capacity

Gearbox approx. 0.8 l (1.41 Imp. pint)
(to bottom edge of filler neck)

Final drive approx. 0.25 l (0.44 Imp.pint)
(to bottom edge of filler screw)

Viscosity class at outside temperature:

above 5 °C SAE 90

below 5 °C SAE 80

alternatively SAE 80 W 90

Fuel grade **Unleaded super (premium) fuel
DIN 51 607, minimum octane
number 95 (RON) and 85 (MON)**

Fuel tank capacity, usable 18 l (4.07 Imp. pints)
including approx. 5 l (1.1 Imp. pint)
reserve

3

85

Technical data

BMW recommends Castrol



Fluids and lubricants

Bearing lubrication and the remaining lubrication points

Brand-name anti-friction bearing grease, usable temperature range $-25\text{ }^{\circ}\text{C} \dots +120\text{ }^{\circ}\text{C}$, drip point $190\text{ }^{\circ}\text{C}$, high corrosion protection, good resistance to water and oxidation; e.g. Shell Retinax EP2

Battery posts – oxidation protection

Acid-free grease, e.g. Vaseline

Brake fluid

DOT 4

We recommend BMW brake fluids



Caution:

Use only new brake fluid to DOT 4 specification.

Electrical system

Battery	Low-maintenance, resistant to total discharge BMW Mareg 12 V, 14 A/h
Optional extra	BMW Mareg 12 V, 19 A/h
Spark plugs	
Approved makes/types	NGK BRK 7 EKC
Electrode gap	0.8 mm (0.03 in)
Wear limit	1.0 mm (0.04 in)
Fuses	“Minifuse” flat-socket fuses
Load ratings	4 A and 15 A
Headlight	Twin-unit, halogen bulbs
Bulbs	
Low (dipped) beam	H1 halogen bulb, 12 V 55 W
High (main) beam	H7 halogen bulb, 12 V 55 W
Parking light	12 V 5 W Standard designation W 5 W
Combined brake and rear light	12 V 21/5 W Standard designation P 25-2
Flashing turn indicators	12 V 21 W Standard designation P 25-1
Number plate light	12 V 5 W Standard designation C 11
Alternator	
Nominal output	600 W
Optional extra	700 W
Starter motor	
Nominal output	1,100 W

Dimensions and weights

Overall length 2,180 mm (85.83 in)

Width

- across mirrors 880 mm (34.65 in)

- across front footrests 580 mm (22.83 in)

- across rear footrests 730 mm (28.74 in)

Overall height

(excl. mirrors) 1,160 mm (45.67 in)

Seat height, unladen 800 mm (31.5 in)

Wheelbase

at unladen weight 1,472 mm (57.95 in)

- in normal-load position 1,478 mm (58.19 in)

Ground clearance

at unladen weight 172 mm (6.77 in)

- in normal-load position 150 mm (5.90 in)

Unladen weight

(ready to ride, tank full) 229 kg (505 lb)

Dry weight 208 kg (459 lb)

Gross weight limit 450 kg (992 lb)

Payload 221 kg (487 lb)

Permissible wheel loads

front 180 kg (397 lb)

rear 300 kg (661 lb)

Performance data

Top speed

acc. to type approval test 225 km/h (140 mph)

Flexibility

4th gear 80-120 km/h
(50-75 mph) 3.4 s

5th gear 80-120 km/h
(50-75 mph) 4.3 s

6th gear 80-120 km/h
(50-75 mph) 5.1 s

4th gear 60-140 km/h
(37-87 mph) 6.9 s

5th gear 60-140 km/h
(37-87 mph) 8.5 s

Power-weight ratio

- ready for road + rider 4.36 kg/kW (9.61 lb/kW)
(85 kg/187 lb)

- at gross weight limit 6.25 kg/kW (13.78 lb/kW)

Ride-past noise level

to 97/24-9/EC 80 dB (A)

Stationary noise level

to 97/24-9/EC 86 dB (A)

Drag coefficient

cd x A, rider seated 0.45

cd x A, rider crouched 0.37

A - E

A

- Accessories, 2
- Annual Service
 - notes, 3
- Auxiliary stand, 24, 25, 26, 27

B

- Battery, 87
 - battery acid, 68
 - charging, 67
 - installing, 71
 - maintenance instructions, 67
 - removing, 69
 - safety instructions, 66, 67, 68
 - warranty, 67
- Bore/stroke, 78
- Brake caliper, removing
 - rear wheel, 38
- Brakes
 - brake fluid, 86
 - brake light, 58
 - minimum pad thickness, 42, 43
 - pad wear indicating marks, 42
 - technical data, 80

Bulbs

- changing
 - brake/rear light, 58
 - front turn indicators, 56
 - high-beam headlight, 52
 - low-beam headlight, 54
 - number plate light, 59
 - parking light, 51
 - rear turn indicators, 57
- notes, 50
- technical data, 87

C

- Capacities
 - engine, 84
- Care products, 75
- Castor, 81
- Chromed parts
 - care of, 75
- Cleaning/care, 73
 - chrome, 75
 - general instructions, 72
 - paint damage, touching up, 75
 - road salt, 74
 - silencer assembly, 75
 - windscreen, 74
- Clutch, 79
- Compression ratio, 78
- Confirmations of maintenance
 - work, 7, 8
- Confirmations of service
 - work, 14, 15, 16
 - renewing odometer, 17

D

- Dimensions, 88
- Displacement, 78
- Drag coefficient, 89

E

- Electrical system, 87
- Engine oil
 - consumption, 78
 - technical data, 84
 - viscosity, 84
- Engine oil capacity, 84
- Engine size, 78

Engine speed

limits, 78

Engine, type, 78

F

Flexibility, 89

Frame, 80

Front turn indicators, 56

Front wheel

installing, 34

removing, 30

technical data, 83

Fuel

consumption, 78

grade, 85

mixture preparation, 78

Fuel and lubricants, 84, 86

Fuses

equipment connected, 60

renewing, 61

technical data, 87

G

Gearbox

oil capacity, 85

oil grades, 85

ratios, 79

technical data, 79

General instructions, 18, 19, 20

General Operating Permit, 2

Gross weight, 88

Ground clearance, 88

H

Headlight, 54, 55

Headlight beam setting for riding

on left/right, 46, 47, 48, 49

Height (excl. mirrors), 88

High beam, 52, 53

I

Idle speed, 78

Inspection

confirmations, 8

Instructions, 18

L

Laying up, motorcycle, 76

M

Maintenance schedule, 4, 5, 6

Modifications, technical, 19

Motorcycle

laying up, 76

Motorcycle documents

storage, 23

N

Noise emissions, 89

Number plate light, 59

O

Oil capacity

gearbox, 85

Overall length, 88

P

Paint damage, touching up, 75

Paralever, 81

Parking light, 51

Performance data, 89

Plastic parts

cleaning, 72

Power output, 78
Power-weight ratio, 89
Products, approved, 2

R

Rear turn indicators, 57
Rear wheel
 installing, 40
 removing, 37
 technical data, 83
Rear wheel drive
 technical data, 79
Rear/brake light, 58
Repair kit, 23
Restoring motorcycle to use, 77

S

Safety information, 2
Safety instructions, 18, 46, 50, 62
Salt damage, 74
Seat height, 88
Service, instructions, 3
Side panels, 44, 45
Side stand, 80
Spark plugs, 87
Steam-jet/high-pressure cleaning
 equipment, 72
Steering lock angle, 81
Suspension
 technical data, 81
Suspension travel, rear, 82

T

Technical data, from page, 78
Tightening torques
 front wheel, 36

 brake caliper, 36
 rear wheel, 41
 brake caliper, 41
Toolkit, 21, 23
Tools, 21
 tyre repair kit, 23
Top speed, 89
Torque, 78
Trickle charger, 67
Troubleshooting, 28, 29
Type plate, 80
Tyres, 83
 approved tyre sizes, 83
 damage, 23
 pressures, 82
 technical data, 83
 tread depth, 83

U

Unladen weight, 88

W

Weights, 88
Wheelbase, 88
Wheels
 loads, 88
 location, 81
 technical data, 83
Width, 88

Motorcycle data

Model

Frame No.

Colour No.

First registered on

Registration No.

Dealer data

Person to contact for Service work

Ms./Mr.

Tel. No.

Dealer's address with telephone No. (company stamp)

Details described or illustrated in this booklet may differ from the motorcycle's actual specification as purchased, the accessories fitted or the national-market specification. No claims will be entertained as a result of such discrepancies. Dimensions, weights, fuel consumption and performance data are quoted to the customary tolerances.

The right to modify designs, equipment and accessories is reserved.
Errors and omissions excepted.
© 2000 BMW Motorrad
Not to be reproduced either wholly or in part without written permission from BMW Motorrad.

Printed in Germany

BMW recommends Castrol



BMW Motorrad

Order No. 01 41 7 664 371

10.00 5th edition GB / RF