

# Rider's Manual

## R 1200 GS Adventure



BMW Motorrad



The Ultimate Riding  
Machine

## Motorcycle data/dealership details

### Motorcycle data

---

Model

---

Vehicle identification number

---

Colour code

---

Date of first registration

---

Registration number

### Dealership details

---

Person to contact in Service department

---

Ms/Mr

---

Phone number

---

Dealership address/phone number  
(company stamp)

## **Welcome to BMW**

We congratulate you on your choice of a motorcycle from BMW and welcome you to the community of BMW riders. Familiarise yourself with your new motorcycle so that you can ride it safely and confidently in all traffic situations. Please read this Rider's Manual carefully before starting to use your new BMW motorcycle. It contains important information on how to operate the controls and how to make the best possible use of all your BMW's technical features. In addition, it contains information on maintenance and care to help you maintain your motorcycle's reliability and safety, as well as its value. If you have questions concerning your motorcycle, your

authorised BMW Motorrad dealer will gladly provide advice and assistance.

We hope that you will enjoy riding your BMW and that all your journeys will be pleasant and safe.

BMW Motorrad.

## Table of Contents

You can also consult the index at the end of this Rider's Manual if you want to find a particular topic or item of information.

### **1 General instructions ... 5**

Overview .....	6
Abbreviations and symbols .....	6
Equipment .....	7
Technical data .....	7
Currency .....	7

### **2 General views ..... 9**

General view, left side ...	11
General view, right side .....	13
Underneath the seat .....	14
Handlebar fitting, left .....	15
Handlebar fitting, right ...	16
Instrument cluster .....	17
Headlight .....	18

### **3 Status indicators ..... 19**

Multifunction display .....	20
Warning and telltale lights .....	20
ABS warning light <sup>OE</sup> .....	20
Function indicators .....	20
Warnings, general .....	21
Warnings issued by the tyre pressure monitoring system (RDC) <sup>OE</sup> .....	28
ABS warnings <sup>OE</sup> .....	33
ASC warnings <sup>OE</sup> .....	35

### **4 Operation ..... 39**

Ignition switch and steering lock .....	40
Electronic immobiliser (EWS) .....	41
Hazard warning flashers .....	42
Odometer and tripmeters .....	43
Tyre pressure monitoring RDC <sup>OE</sup> .....	44

Clock .....	45
On-board computer <sup>OE</sup> ...	46
BMW Motorrad Integral ABS <sup>OE</sup> .....	50
Automatic Stability Control ASC <sup>OE</sup> .....	51
Emergency off switch (kill switch) .....	53
Grip heating <sup>OE</sup> .....	54
Clutch .....	54
Brakes .....	55
Shift lever .....	56
Lights .....	57
Headlight .....	59
Turn indicators .....	60
Front and rear seats .....	61
Helmet holder .....	63
Mirrors .....	63
Adjusting windscreen ...	64
Spring preload .....	64
Shock absorbers .....	66
Tyres .....	67

<b>5 Riding</b> .....	<b>69</b>	<b>7 Maintenance</b> .....	<b>99</b>	<b>8 Care</b> .....	<b>135</b>
Safety instructions .....	70	General instructions ....	100	Care products .....	136
Checklist .....	72	Toolkit .....	100	Washing the	
Starting .....	72	Engine oil .....	102	motorcycle .....	136
Running in .....	75	Brake system,		Cleaning easily damaged	
Riding off-road .....	76	general .....	103	components.....	137
Park your motorcycle ....	77	Brake pads.....	104	Paint care .....	138
Refuelling .....	78	Brake fluid .....	106	Protective wax	
Tyre pressure monitoring		Clutch .....	108	coating .....	138
RDC <sup>OE</sup> .....	80	Tyres .....	109	Laying up the	
Brake system, general ...	81	Rims .....	109	motorcycle .....	138
Brake system with BMW		Wheels.....	110	Restoring motorcycle to	
Motorrad Integral		Front-wheel stand .....	116	use .....	139
ABS <sup>OE</sup> .....	82	Bulbs .....	117	<b>9 Technical data</b> .....	<b>141</b>
Electronic engine		Air filter .....	126	Troubleshooting	
management with BMW		Removing right side		chart.....	142
Motorrad ASC <sup>OE</sup> .....	85	panel .....	129	Threaded fasteners .....	143
<b>6 Accessories</b> .....	<b>89</b>	Installing right side		Engine .....	144
General instructions ....	90	panel .....	129	Riding specifications....	147
Power socket .....	90	Jump start .....	129	Clutch .....	147
Luggage .....	91	Battery .....	131	Transmission .....	147
Case <sup>OA</sup> .....	92			Final drive .....	148
Topcase <sup>OA</sup> .....	95			Running gear.....	148
				Brakes .....	149
				Wheels and tyres .....	149

Electrics .....	150
Frame .....	152
Dimensions .....	153
Weights .....	153
<b>10 Service .....</b>	<b>155</b>
BMW Motorrad service .....	156
BMW Motorrad service quality .....	156
BMW Motorrad Service Card: on-the-spot breakdown assistance .....	157
BMW Motorrad service network .....	157
Maintenance work .....	157
Maintenance schedules .....	158
Confirmation of maintenance work .....	159
Confirmation of service .....	164

## General instructions

Overview .....	6
Abbreviations and symbols .....	6
Equipment .....	7
Technical data .....	7
Currency .....	7

## Overview

Chapter 2 of this Rider's Manual will provide you with an initial overview of your motorcycle. All maintenance and servicing work on the motorcycle is documented in Chapter 10. This record of the maintenance work you have had performed on your motorcycle is a precondition for generous treatment of goodwill claims.

When the time comes to sell your BMW, please remember to hand over this Rider's Manual; it is an important part of the motorcycle.

## Abbreviations and symbols

 Indicates warnings that you must comply with for reasons of your safety and the safety of others, and to pro-

tect your motorcycle against damage.

 Specific instructions on how to operate, control, adjust or look after items of equipment on the motorcycle.

◀ Indicates the end of an item of information.

• Instruction.

» Result of an activity.

 Reference to a page with more detailed information.

◁ Indicates the end of a passage relating to specific accessories or items of equipment.

 Tightening torque.



Item of technical data.

OE Optional extra  
Your motorcycle was assembled complete with all the BMW optional extras you ordered.

OA Optional accessory  
You can obtain optional accessories through your authorised BMW Motorrad dealer; optional accessories have to be retrofitted to the motorcycle.

EWS Electronic immobiliser (Elektronische Wegfahrsicherung).

DWA Anti-theft alarm (Diebstahlwarnanlage)

ABS Anti-lock brake system

ASC Automatic Stability Control.

RDC Tyre pressure control (ReifenDruck-Control)

## Equipment

When you ordered your BMW motorcycle, you chose various items of custom equipment. This Rider's Manual describes optional extras (OE) offered by BMW and selected optional accessories (OA). This explains why the manual may also contain descriptions of equipment which you have not ordered. Please note, too, that your motorcycle might not be exactly as illustrated in this manual on account of country-specific differences. If your BMW was supplied with equipment not described

in this Rider's Manual, you will find these features described in separate manuals.

## Technical data

All dimensions, weights and power ratings stated in the Rider's Manual are quoted to the standards and comply with the tolerance requirements of the Deutsche Institut für Normung e.V. Versions for individual countries may differ.

## Currency

The high safety and quality standards of BMW motorcycles are maintained by constant development work on designs, equipment and accessories. Because of this, your motorcycle may differ from the information supplied in the Rider's Manual. Nor can BMW Motorrad entirely rule out errors and omissions.

We hope you will appreciate that no claims can be entertained on the basis of the data, illustrations or descriptions in this manual.



## General views

General view, left side .....	11
General view, right side .....	13
Underneath the seat .....	14
Handlebar fitting, left .....	15
Handlebar fitting, right .....	16
Instrument cluster .....	17
Headlight .....	18



## General view, left side

- 1 Clutch-fluid reservoir  
(⇒ 108)
- 2 Adjuster for headlight  
beam throw underneath  
the instrument cluster  
(⇒ 59)
- 3 Adjuster, damping, rear  
(⇒ 66)
- 4 Seat lock (⇒ 61)
- 5 Power socket (⇒ 90)
- 6 Filler neck, engine oil  
(⇒ 103)
- 7 Oil sight glass (⇒ 102)
- 8 Adjuster, spring preload,  
front (⇒ 65)
- 9 Socket (OA) (⇒ 90)
- 10 Adjustable windscreen  
(⇒ 64)



## General view, right side

- 1 Filler neck, fuel (⇒ 78)
- 2 Vehicle Identification Number (VIN) on steering-head bearing
- 3 Brake-fluid reservoir, front (⇒ 106)
- 4 Air filter (underneath tank cover) (⇒ 126)
- 5 Adjustable footbrake lever (⇒ 55)
- 6 Adjuster, spring preload, rear (⇒ 64)
- 7 Brake-fluid reservoir, rear (⇒ 107)

## Underneath the seat

- 1 Battery (➔ 133)
- 2 Rider's Manual
- 3 Toolkit (➔ 100)
- 4 Puncture repair kit (OA) underneath toolkit
- 5 Helmet holder (➔ 63)

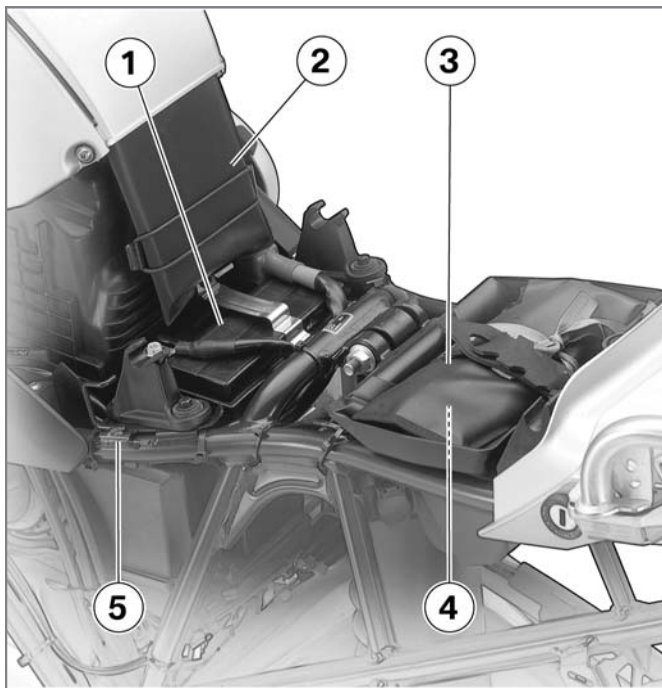



## Handlebar fitting, left

- 1 Control, odometer (➔ 43), Control, on-board computer<sup>OE</sup> (➔ 46)
- 2 Pushbutton, ASC<sup>OE</sup> (➔ 51)
- 3 Pushbutton, ABS<sup>OE</sup> (➔ 50)
- 4 Pushbutton, horn
- 5 Pushbutton, left flashing turn indicators (➔ 60), Pushbutton, hazard warning flashers (➔ 42)
- 6 Switch, high-beam headlight (➔ 57), Switch for headlight flasher

## Handlebar fitting, right

- 1 Emergency off switch (kill switch) (➔ 53)
- 2 Pushbutton, starter (➔ 72)
- 3 Pushbutton, right flashing turn indicators (➔ 60), Pushbutton, hazard warning flashers (➔ 42)
- 4 Cancel button, flashing turn indicators (➔ 61), Pushbutton, cancel hazard warning flashers (➔ 43)
- 5 Grip heating switch<sup>OE</sup> (➔ 54)

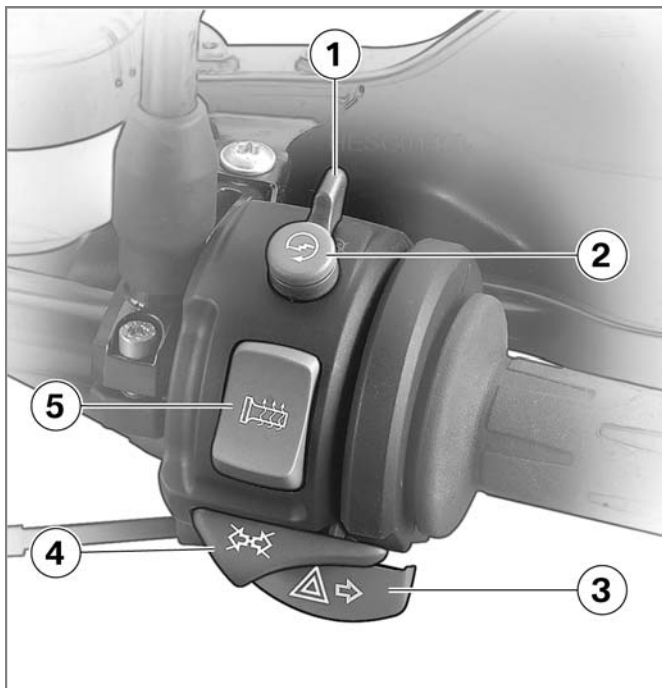

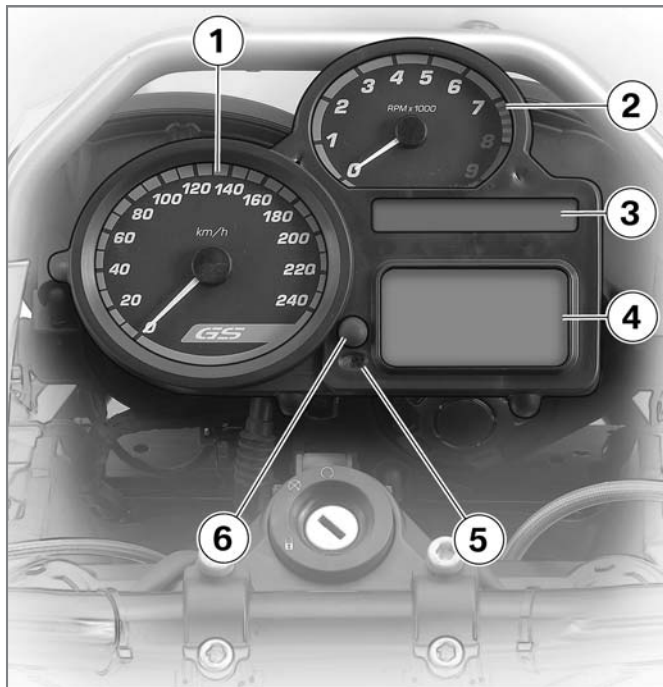

## Instrument cluster

- 1 Speedometer
- 2 Rev. counter
- 3 Warning and telltale lights (⇒ 21)
- 4 Multifunction display (⇒ 21)
- 5 Telltale light for anti-theft alarm (OE) and sensor for instrument cluster lighting
- 6 Adjuster, clock (⇒ 45), Control, odometer (⇒ 43)

## Headlight

- 1 Low-beam headlight
- 2 High-beam headlight
- 3 Side lights

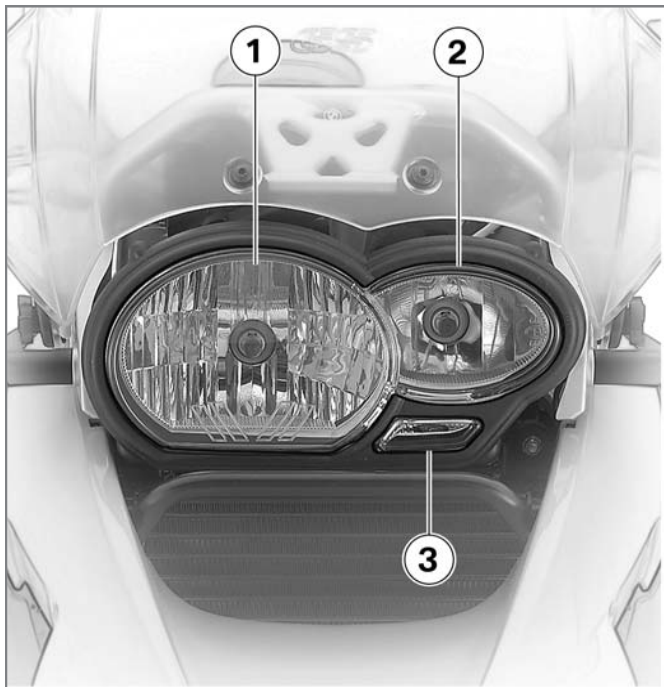

## Status indicators

Multifunction display .....	20
Warning and telltale lights .....	20
ABS warning light <sup>OE</sup> .....	20
Function indicators .....	20
Warnings, general .....	21
Warnings issued by the tyre pressure monitoring system (RDC) <sup>OE</sup> .....	28
ABS warnings <sup>OE</sup> .....	33
ASC warnings <sup>OE</sup> .....	35

## Multifunction display

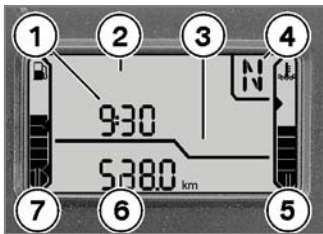

- 1 Clock (⇒ 45), Panel for RDC status indicators<sup>OE</sup> (⇒ 44), Panel for oil-level information<sup>OE</sup> (⇒ 49)
- 2 Panel for warnings (⇒ 21)
- 3 Panel for the on-board computer's status indicators<sup>OE</sup> (⇒ 46)
- 4 Gear indicator (⇒ 20)
- 5 Engine-oil temperature display (⇒ 21)
- 6 Odometer reading (⇒ 43)
- 7 Fuel gauge (⇒ 20)

## Warning and telltale lights

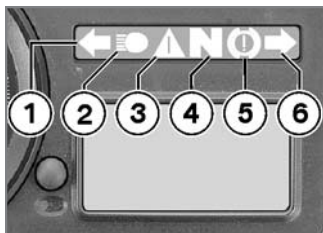

- 1 Telltale light, left turn indicator
- 2 Telltale light, high-beam headlight
- 3 Warning light, general
- 4 Telltale light, neutral
- 5 Warning light, ABS (OE)
- 6 Telltale light, right turn indicator

## ABS warning light<sup>OE</sup>

The way in which the ABS warning light indicates status can differ in some countries.

 Possible national variant.

## Function indicators

### Fuel capacity

 The horizontal bars below the fuel-pump symbol indicate the remaining quantity of fuel.

### Gear

 Shows which gear is engaged. If no gear is engaged, the gear indicator shows N and the 'neutral' telltale light also lights up.

## Engine temperature

 The horizontal bars below the temperature symbol indicate the engine temperature.

## ASC intervention (OE)

 General warning light quick-flashes yellow.

 ASC symbol shows.

The ASC has detected a degree of instability at the rear wheel and has intervened to reduce torque. The warning light flashes for one second longer than ASC intervention lasts. This affords the rider visual feedback on control intervention even after the critical situation has been dealt with.

## Off-road ASC intervention (OE)

 General warning light quick-flashes yellow.

 Off-road ASC symbol shows.

The off-road ASC has detected a degree of instability at the rear wheel and has intervened to reduce torque. The warning light flashes for one second longer than ASC intervention lasts. This affords the rider visual feedback on control intervention even after the critical situation has been dealt with.

## Warnings, general

### Mode of presentation











General warnings are displayed by means of texts and symbols in the multifunction display. In some

cases, they are accompanied by the 'General' warning light showing red or yellow. If two or more warnings occur at the same time, all the appropriate telltale lights and warning symbols appear. Warnings in text form alternate.

## Warnings, overview



### Mode of presentation

### Meaning

	Lights up yellow		The EWS ! warning appears on the display.	Electronic immobiliser active (➡ 24)
	Lights up yellow		The FUEL ! warning appears on the display.	Fuel down to reserve (➡ 24)
	Lights up yellow		Appears on the display	Engine electronics (➡ 24)
	Flashes red		Appears on the display	Insufficient engine oil pressure (➡ 25)
			Shows accompanied by the CHECK OIL warning	Engine-oil level too low (➡ 25)
	Lights up red		Appears on the display	Insufficient battery charge current (➡ 26)
	Lights up yellow		The LAMPR ! warning appears on the display.	Rear light bulb defective (➡ 26)

## Mode of presentation

## Meaning

		The LAMPF ! warning appears on the display.	Front light bulb defective (➡ 26)
	Lights up yellow	The LAMPS ! warning appears on the display.	Bulbs defective (➡ 27)
		 Appears on the display	Ice warning (OE) (➡ 27)
		The DWALO ! warning appears on the display.	Battery of anti-theft alarm (OE) weak (➡ 27)
	Lights up yellow	The DWA ! warning appears on the display.	Anti-theft alarm battery flat (OE) (➡ 28)

### Electronic immobiliser active

 General warning light lights up yellow.

The EWS ! warning appears on the display.

The key being used is not authorised for starting, or communication between key and engine electronics is disrupted.

- Remove all other vehicle keys from the same ring as the ignition key.
- Use the reserve key.
- Have the defective key replaced, preferably by an authorised BMW Motorrad dealer.

### Fuel down to reserve

 General warning light lights up yellow.

The FUEL ! warning appears on the display.

 Lack of fuel can result in the engine misfiring and cutting out unexpectedly. Misfiring can damage the catalytic converter; a hazardous situation can result if the engine cuts out unexpectedly. Do not run the fuel tank dry. ◀

 The estimated residual range appears on the display. ◀

The fuel tank contains no more than the reserve quantity of fuel.

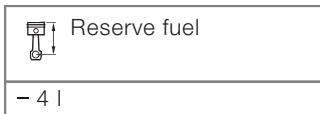

- Refuelling (➡ 78)

### Engine electronics

 General warning light lights up yellow.

 Engine electronics symbol appears on the display.

 The engine is running in emergency operating mode. Engine power might be reduced and this can cause hazardous situations, particularly if you attempt to overtake other road users. Engine power level might be lower than normal: adapt your style of riding accordingly. ◀

The engine electronics control unit has diagnosed a fault. In exceptional cases, the engine stops and refuses to start. Otherwise, the engine runs in emergency operating mode.

- You can continue to ride, but bear in mind that the usual engine power might not be available.
- Have the fault rectified as quickly as possible by a

specialist workshop, preferably an authorised BMW Motorrad dealer.

### Insufficient engine oil pressure



General warning light flashes red.



Engine oil pressure symbol appears on the display.

The oil pressure in the lube-oil system is too low. Stop immediately and switch off the engine if the warning light shows.

 The insufficient oil pressure warning does not fulfil the function of an oil gauge. The only way of checking whether the oil level is correct is to check the oil sight glass. ◀

A low oil level is one reason why a warning indicating insufficient oil pressure is issued.

- Checking engine oil level (➡ 102)

If the oil level is too low:

- Top up the engine oil.

If the warning indicating insufficient engine oil level is issued and a check indicates that the engine oil level is correct:



Other engine problems besides a low oil level can cause the insufficient engine oil pressure warning to be issued. Continuing to ride in these cases can cause engine damage.

If this warning is issued even though the engine oil level is correct: do not continue to ride. ◀

- Do not continue your journey.
- Have the fault rectified as quickly as possible by a specialist workshop, preferably an authorised BMW Motorrad dealer.

### Engine-oil level too low



Symbol for oil level shows, accompanied by the CHECK OIL warning.

The electronic oil-level sensor has registered an excessively low oil level.

The only exact way of checking whether the oil level is correct is to check the oil sight glass. The next time you stop for fuel:

- Checking engine oil level (➡ 102)

If the oil level is too low:

- Topping up the engine oil (➡ 103)

The oil sensor might be defective if the "Check oil level" message appears even though a check at the oil sight glass reveals that the oil level is correct.

- Checking engine oil level (➔ 102)

If the oil level is too low:

- Seek the advice of a specialist workshop, preferably an authorised BMW Motorrad dealer.

### Insufficient battery charge current



General warning light lights up red.



Battery charge current symbol is displayed.



A discharged battery can cause the engine to die suddenly, and this could result in a dangerous situation in traffic.

Have faults rectified as soon as possible.◀



If the battery is not charging, continuing to ride can cause it to discharge completely, in which case it will suffer irreparable damage. If possible, do not continue your journey.◀

Battery is not being charged.

- You can continue to ride until the battery is discharged. Bear in mind, however, that the engine could cut out suddenly and that the battery could discharge until completely flat, in which case it might have suffered irreparable damage.
- Have the fault rectified as quickly as possible by a specialist workshop, preferably an authorised BMW Motorrad dealer.

### Rear light bulb defective



General warning light lights up yellow.

The LAMPRL! warning appears on the display.



A defective bulb places your safety at risk because it is easier for other users to oversee you and your motorcycle.

Replace defective bulbs as soon as possible; always carry a complete set of spare bulbs if possible.◀

Rear light or brake light bulb defective.

- Replacing brake light and rear light bulb (➔ 121)

### Front light bulb defective

The LAMPFL! warning appears on the display.

 A defective bulb places your safety at risk because it is easier for other users to oversee you and your motorcycle.

Replace defective bulbs as soon as possible; always carry a complete set of spare bulbs if possible. ◀

Low-beam headlight, high-beam headlight, side-light or turn-indicator bulb defective.

- Replace the low-beam and high-beam headlight bulb (➔ 118)
- Replacing parking-light bulb (➔ 120)
- Replacing turn indicator bulbs, front and rear (➔ 122)

### **Bulbs defective**

 General warning light lights up yellow.

The LAMPS ! warning appears on the display.

 A defective bulb places your safety at risk because it is easier for other users to oversee you and your motorcycle.

Replace defective bulbs as soon as possible; always carry a complete set of spare bulbs if possible. ◀

A combination of the bulb defects described above has occurred.

- See the fault descriptions above.

### **Ice warning (OE)**

 Ice warning symbol appears on the display.

The air temperature measured at the motorcycle is lower than 3 °C.

 The ice warning does not mean that there is no risk of black ice forming at measured temperatures above 3 °C.

Always take extra care and think well ahead when temperatures are low; remember that the danger of black ice is particularly high on bridges and where the road is in the shade. ◀

- Ride carefully and think well ahead.

### **Battery of anti-theft alarm (OE) weak**

The DWALO ! warning appears on the display.

 This error message appears only briefly after the pre-ride check completes. ◀

The integral battery in the anti-theft alarm has lost a significant proportion of its original capacity. There is no assurance of how long the anti-theft alarm can remain operational if the motorcycle's battery is disconnected.

- Seek the advice of a specialist workshop, preferably an authorised BMW Motorrad dealer.

### Anti-theft alarm battery flat (OE)

 General warning light lights up yellow.

The DWA! warning appears on the display.

 This error message appears only briefly after the pre-ride check completes. ◀

The integral battery in the anti-theft alarm has lost its entire original capacity. There is no assurance that the anti-theft alarm will be operational if the motorcycle's battery is disconnected.

- Seek the advice of a specialist workshop, preferably an authorised BMW Motorrad dealer.

## Warnings issued by the tyre pressure monitoring system (RDC)<sup>OE</sup>

### Display mode for RDC warnings











The tyre pressure for the front wheel **1** and the tyre pressure for the rear wheel **2** appear in the panel for the clock or the on-board computer, accompanied by the letters RDC. The critical tyre pressure flashes

If the critical value is close to the limit of the permissible tolerance range, the reading is accompanied by the 'General' warning light showing yellow. If the tyre pressure registered by the sensor is outside the permissible tolerance range, the 'General' warning light flashes red.

## Warnings, overview

### Mode of presentation

		<b>Meaning</b>		
	Lights up yellow		The critical tyre pressure flashes	Tyre pressure close to limit of permitted tolerance (➡ 31)
	Flashes red		The critical tyre pressure flashes	Tyre pressure outside permitted tolerance (➡ 31)
			"--" or "-- --" appears on the display	Signal transmission disrupted (➡ 32)
	Lights up yellow		Indicated by "--" or "-- --"	Sensor defective or system error (➡ 32)
	Lights up yellow		Indicated by the letters RDC! appearing on the display.	Tyre-pressure sensor battery weak (➡ 33)

## Tyre pressure close to limit of permitted tolerance

 General warning light flashes up yellow.

 The critical tyre pressure flashes.

Measured tyre pressure is close to the limit of permitted tolerance.

- Correct the tyre pressure as stated on the inside cover of the Rider's Manual.

 The tyre-pressures listed on the inside cover are temperature-compensated; the reference tyre temperature for these readings is always 20 °C. The procedure for correctly tyre pressures when the tyres are not at this reference temperature is as follows:

Calculate the difference between the specified value stated in the Rider's Manual

and the reading shown by the RDC system. Use the public air line at a petrol station or motorway service area to adjust the tyre pressure by this amount.◀

## Tyre pressure outside permitted tolerance

 General warning light flashes red.

 The critical tyre pressure flashes.

Measured tyre pressure is outside permitted tolerance.

- Check the tyre for damage and to ascertain whether the motorcycle can be ridden with the tyre in its present condition.

If the motorcycle can be ridden with the tyre in its present condition:

 Incorrect tyre pressures impair the motorcycle's handling characteristics. If tyre pressure is incorrect it is essential to adapt your style of riding accordingly.◀

- Correct the tyre pressure at the earliest possible opportunity.
- Have the tyre checked for damage by a specialist workshop, preferably an authorised BMW Motorrad dealer.

If you are unsure whether the motorcycle can be ridden with the tyre in its present condition:

- Do not continue your journey.
- Notify the breakdown service.
- Have the tyre checked for damage by a specialist workshop, preferably an

authorised BMW Motorrad dealer.

### Signal transmission disrupted

"--" or "-- --" appears on the display.

The motorcycle has not yet accelerated past the threshold of approximately 30 km/h. The RDC sensors do not start transmitting signals until the motorcycle reaches a speed above this threshold (➔ 80).

- Increase speed above this threshold observe the RDC readings. Assume that a permanent fault has not occurred unless the 'General' warning light comes on to accompany the symptoms. Under these circumstances:
- Have the fault rectified by a specialist workshop, prefer-

ably an authorised BMW Motorrad dealer.

Wireless communication with the RDC sensors has been disrupted. Possible causes include radio-communication systems operating in the vicinity and interfering with the link between the RDC control unit and the sensors.

- Move to another location and observe the RDC readings. Assume that a permanent fault has not occurred unless the 'General' warning light comes on to accompany the symptoms. Under these circumstances:
- Have the fault rectified by a specialist workshop, preferably an authorised BMW Motorrad dealer.

### Sensor defective or system error



General warning light lights up yellow.



Indicated by "--" or "-- --".

Motorcycle is fitted with tyres not equipped with RDC sensors.

- Fit wheels and tyres equipped with RDC sensors.

One or two RDC sensors have failed.

- Have the fault rectified by a specialist workshop, preferably an authorised BMW Motorrad dealer.

A system error has occurred.

- Have the fault rectified by a specialist workshop, preferably an authorised BMW Motorrad dealer.

## Tyre-pressure sensor battery weak

 General warning light lights up yellow.

 Indicated by the letters RDC! appearing on the display.

 This error message appears only briefly after the pre-ride check completes.◀

The integral battery in the tyre-pressure sensor has lost a significant proportion of its original capacity. There is no assurance of how long the tyre pressure control system can remain operational.

- Seek the advice of a specialist workshop, preferably an authorised BMW Motorrad dealer.

## ABS warnings<sup>OE</sup>

### Mode of presentation



 ABS warnings are indicated by the ABS warning light. The warning light can show continuously or flash. The way in which the ABS warning light indicates status can differ in some countries.

 Possible national variant.

## Warnings, overview

### Mode of presentation

### Meaning

	Flashes	Self-diagnosis not completed (➡ 35)
	Lights up	ABS switched off (➡ 35)
	Lights up	ABS fault (➡ 35)

## Self-diagnosis not completed

 ABS warning light flashes.

The ABS function is not available, because self-diagnosis did not complete. The motorcycle has to move forward a few metres for the wheel sensors to be tested.

- Pull away slowly. Bear in mind that the ABS function is not available until self-diagnosis has completed.

## ABS switched off

 ABS warning light ON.

The rider has switched off the ABS system.  
with OE BMW Motorrad Integral ABS:

- Activate the ABS function (➔ 51)

## ABS fault

 ABS warning light ON.

The ABS control unit has detected a fault. The ABS function is not available.

- You can continue to ride. Bear in mind that the ABS function is not available. Bear in mind the more detailed information on situations that can lead to an ABS fault (➔ 84).
- Have the fault rectified as quickly as possible by a specialist workshop, preferably an authorised BMW Motorrad dealer.

## ASC warnings<sup>OE</sup>

### Mode of presentation

 ASC warnings are indicated by a combination of the ASC warning symbol and the "General" warning light.





The ASC warning light can show continuously or flash.

 In off-road mode ASC warnings are indicated by this warning symbol.

## Warnings, overview

### Mode of presentation

### Meaning

		Slow-flashes	Self-diagnosis not completed (⇒ 37)
		Slow-flashes	Self-diagnosis in off-road mode not completed (⇒ 37)
		Appears on the display	ASC switched off (⇒ 37)
	Lights up yellow		Appears on the display ASC fault (⇒ 37)

## Self-diagnosis not completed



ASC symbol slow-flashes.

Self-diagnosis did not complete, so the ASC function is not available. The engine must be running and the motorcycle must reach a speed of at least 5 km/h in order for ASC self-diagnosis to complete.

- Pull away slowly. Bear in mind that the ASC function is not available until self-diagnosis has completed.

## Self-diagnosis in off-road mode not completed



Off-road ASC symbol slow-flashes.

Off-road mode was selected before ASC self-diagnosis completed. The off-road ASC function is not yet available.

The engine must be running and the motorcycle must reach a speed of at least 5 km/h in order for ASC self-diagnosis to complete.

- Pull away slowly. Bear in mind that the ASC function is not available until self-diagnosis has completed.

## ASC switched off



ASC symbol appears on the display.

The rider has switched off the ASC system.

with OE Automatic Stability Control (ASC):

- Activate the ASC function (⇒ 52)

## ASC fault



General warning light lights up yellow.



ASC symbol appears on the display.

The ASC control unit has detected a fault. The ASC function and the off-road ASC function are not available.

- You can continue to ride. Bear in mind that the ASC function is not available. Bear in mind the more detailed information on situations that can lead to an ASC fault (⇒ 86).
- Have the fault rectified as quickly as possible by a specialist workshop, preferably an authorised BMW Motorrad dealer.



## Operation

Ignition switch and steering lock.....	40	Clutch .....	54
Electronic immobiliser (EWS) ...	41	Brakes .....	55
Hazard warning flashers .....	42	Shift lever .....	56
Odometer and tripmeters .....	43	Lights .....	57
Tyre pressure monitoring RDC <sup>OE</sup> .....	44	Headlight .....	59
Clock .....	45	Turn indicators .....	60
On-board computer <sup>OE</sup> .....	46	Front and rear seats .....	61
BMW Motorrad Integral ABS <sup>OE</sup> .....	50	Helmet holder .....	63
Automatic Stability Control ASC <sup>OE</sup> .....	51	Mirrors .....	63
Emergency off switch (kill switch) .....	53	Adjusting windscreen .....	64
Grip heating <sup>OE</sup> .....	54	Spring preload .....	64
		Shock absorbers .....	66
		Tyres .....	67

## Ignition switch and steering lock

### Keys

You receive one master key and one spare key. Please consult the information on the electronic immobiliser (EWS) if a key is lost or mislaid (➡ 41).

▶ Ignition switch and steering lock, tank filler cap lock and seat lock are all operated with the same key. On request, the cases and the topcase available as optional accessories can be arranged to lock with the same key. ◀

## Switching on ignition



- Turn the key to position **1**.
  - » Side lights and all function circuits switched on.
  - » Engine can be started.
  - » Pre-ride check is performed. (➡ 73)

with OE BMW Motorrad Integral ABS:

- Turn the key to position **1**.
  - » ABS self-diagnosis is performed in addition to the checks outlined above. (➡ 74)◀

with OE Automatic Stability Control (ASC):

- Turn the key to position **1**.
  - » ASC self-diagnosis is performed in addition to the checks outlined above. (➡ 74)◀

## Switching off ignition



- Turn the key to position **2**.
  - » Lights switched off.
  - » Handlebars not locked.
  - » Key can be removed.
  - » Electrically powered accessories remain opera-

tional for a limited period of time.

- » The battery can be recharged via the on-board socket.

## Locking handlebars



**!** If the motorcycle is on the side stand, the surface of the ground will determine whether it is better to turn the handlebars to the left or right. However, the motorcycle is more stable on a level surface with the handlebars turned to the left than

with the handlebars turned to the right.

On level ground, always turn the handlebars to the left to set the steering lock.◀

- Turn the handlebars to the full left or right lock position.
- Turn the key to position **3**, while moving the handlebars slightly.
  - » Ignition, lights and all function circuits switched off.
  - » Handlebars locked.
  - » Key can be removed.

## Electronic immobiliser (EWS)

### Protection against theft

The electronic immobiliser helps protect your BMW motorcycle from theft, and this enhanced security is at your disposal without any need for you to set parameters or activate additional systems. The

engine of a motorcycle fitted with this electronic immobiliser can be started only with the keys that belong to the vehicle. You can also have your authorised BMW Motorrad dealer bar individual keys, for example if a particular key goes missing. The engine cannot be started with a key that has been barred.

### In-key electronics

An electronic component is integrated into each of your keys. The motorcycle's electronics exchange certain continuously changing signals with the electronics in the key; these signals are specific to your motorcycle and they are transmitted via the ring aerial in the ignition lock. The ignition is not enabled for starting until the key has been

recognised as "authorised" for your motorcycle.

▶ A spare key attached to the same ring as the ignition key used to start the engine could "irritate" the electronics, in which case the enabling signal for starting is not issued. The EWS warning appears in the multifunction display.

Always keep the spare key separately from the ignition key. ◀

## Replacement and extra keys

You can obtain replacement/extra keys only through an authorised BMW Motorrad dealer. The keys are part of an integrated security system, so the dealer is under an obligation to check the legitimacy of all applications for replacement/extra keys. If

you want to have a lost key barred, you have to bring with you all the other keys that belong to the motorcycle. A key that has been barred can subsequently be cleared and reactivated for use.

## Hazard warning flashers

### Switching on hazard warning flashers

- Switch on the ignition.

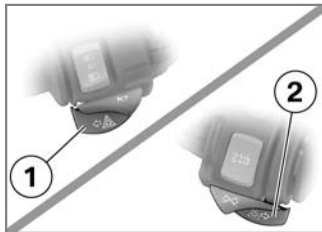

- Simultaneously press button **1** for left turn indicators

and button **2** for right turn indicators.

▶ The hazard warning flashers place a strain on the battery. Do not use the hazard warning flashers for longer than absolutely necessary. ◀

▶ If you press a turn-indicator button with the ignition switched on, the turn-indicator function is activated instead of the hazard warning flashers, and remains active until you release the button. The hazard warning flashers recommence flashing as soon as the button is released. ◀

- » Hazard warning flashers in operation.
- » Left/right turn indicator tell-tale lights flash.
- Switch off the ignition.
- » The hazard warning flashers continue to operate.

- » Left/right turn indicator tell-tale lights off.

## Switching off hazard warning flashers



- Press cancel button **1**.
- » Hazard warning flashers switched off.

## Odometer and tripmeters

### Operating the odometer



If the motorcycle is not equipped with on-board computer and RDC, you can use INFO button **1** to operate the odometer as described here.

### Selecting readings

- Switch on the ignition.

▶ When you switch on the ignition, the odometer reading shown when the ignition was switched off always

reappears on the multifunction display. ◀

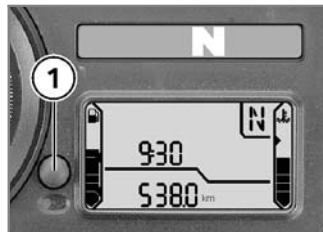

- Press button **1** once briefly.

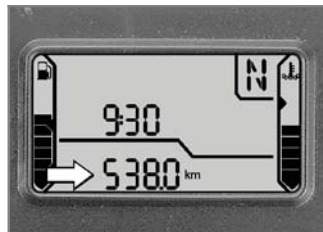

The odometer's display field starts with the current value

and cycles through the following sequence:

- Total distance covered
- Tripmeter 1 (Trip I)
- Tripmeter 2 (Trip II)
- Residual range (once fuel level is down to reserve)

### Resetting tripmeter

- Switch on the ignition.
- Select the desired tripmeter.

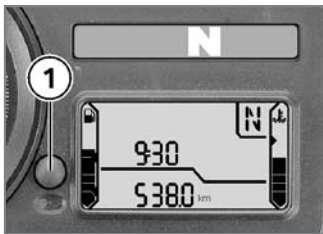

- Press and hold down button **1** until the reading changes.
- » The tripmeter is reset to zero.

### Residual range

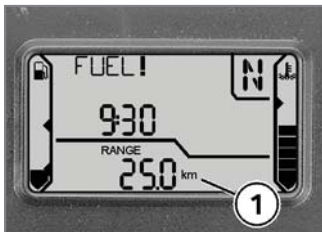

Residual-range reading **1** appears accompanied by the word RANGE and indicates how far you can ride with the fuel remaining in the tank. On a motorcycle not equipped with an on-board computer (OE), this reading is not displayed until the fuel level has dropped to reserve. This distance is calculated on the basis of fuel level and average consumption.

When you refuel, the increase in fuel level is not registered unless several litres are ad-

ded to the fuel already in the tank.

▶ The residual range is only an approximate reading. Consequently, BMW Motorrad recommends that you should not try to use the full residual range before refuelling.◀

### Tyre pressure monitoring RDC<sup>OE</sup>

#### Viewing tyre-pressure readings

- Switch on the ignition.



the rear tyre pressure. If your motorcycle is fitted with an on-board computer, the tyre pressures are displayed as an additional set of readings by the on-board computer.

## Clock

### Setting clock

 Attempting to set the clock while riding the motorcycle can lead to accidents.

Set the clock only when the motorcycle is stationary. ◀

- Switch on the ignition.



The tyre-pressure readings alternate with the clock. The front tyre pressure is on the left; the reading on the right is



- Repeatedly press INFO button **1** until the total distance covered reading appears on the display.

with OE On-board computer:



- Repeatedly press INFO button **1** until the clock appears on the display.<

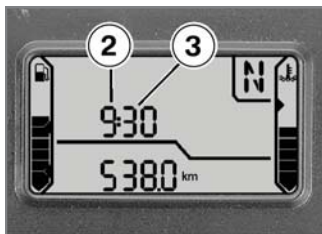

- Press and hold down the INFO button until the reading changes.
  - » Hours reading **2** starts to flash.
- Press the INFO button.
  - » The hour increments by one each time you press the button.
- Press and hold down the INFO button until the reading changes.
  - » Minutes reading **3** starts to flash.
- Press the INFO button.

» The minute increments by one each time you press the button.

- Press and hold down the INFO button until the reading changes.
- » The reading stops flashing.
- » The time is now set.

## On-board computer<sup>OE</sup>

### Selecting readings

- Switch on the ignition.



- Press INFO button **1** once at each step.



## Ambient temperature

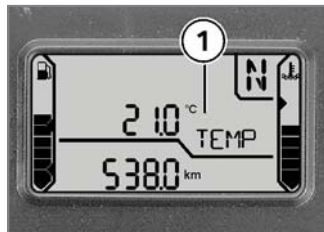

Ambient-temperature display **1** is active only when the engine is running; at other times the display shows ---.

 An ice warning appears if the ambient-temperature reading drops below 3 °C. The display automatically switches from any other mode to the temperature reading when the temperature drops below this threshold for the first time. The reading flashes until you

select some other display mode.

## Calculating average speed



Average speed **1** is calculated on basis of the time elapsed since the last RESET. Times during which the engine was stopped are excluded from the calculation.

## Resetting average speed



- Repeatedly press INFO button **1** until the average speed appears in the display.
- Hold the INFO button down for at least 2 seconds (RESET).
  - » The display shows "---.-- km/h".

## Calculating average consumption



Average consumption **1** is calculated by dividing the distance covered since the last RESET by the corresponding amount of fuel used.

## Resetting average consumption



- Repeatedly press INFO button **1** until the average fuel consumption appears in the display.
- Hold the INFO button down for at least 2 seconds (RESET).
  - » The display shows "---.- l/100 km".

## Range

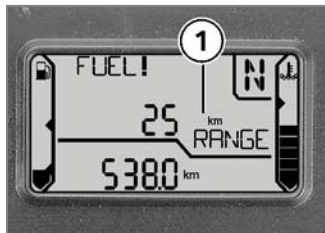

The description of the residual-range function (➔ 44) also covers the residual-range readout. You can also view range **1** before the fuel level drops to reserve. A special average-consumption figure is used to calculate range; this figure is not necessarily the same as the value you can call up for viewing on the display.

▶ The calculated range is only an approximate reading. Consequently, BMW Motorrad recommends that you should not try to use the full range before refuelling. ◀

## Oil level



Oil-level indicator **1** gives you an indication of the engine oil level. You can call up this reading only when the motorcycle is at a standstill.

The preconditions for the oil level check are as follows:

- Engine idling for at least 10 seconds.
- Engine at operating temperature.
- Side stand retracted.

The readings mean:

OK: Oil level is correct.

CHECK: Check the oil level in the sight glass the next time you stop for fuel.



Remains visible until the sensor subsequently registers a correct oil level.

---: Oil level cannot be measured (conditions as stated above not satisfied).

The most recently measured level is displayed for 5 seconds when you next switch on the ignition.

▶ The oil sensor might be defective if the "Check oil level" message reappears even though the oil level in the oil sight glass is correct. In this case, consult your authorised BMW Motorrad dealer. ◀

## BMW Motorrad Integral ABS<sup>OE</sup>

### Deactivating ABS function

- Switch on the ignition.

▶ You can deactivate the ABS function only when the motorcycle is at a standstill. ◀



- Press and hold down ABS button **1**.

ⓘ ABS warning light shows; if self-diagnosis has not completed the ABS warning light changes from flashing to ON.

- When the ABS warning light comes on, release the ABS button within five seconds.
- » The ABS function is deactivated.

ⓘ ABS warning light remains ON.

### Response with ABS deactivated

If you deactivate the ABS, the function is initially disabled for the front wheel only. If you apply the brakes by pulling only the handbrake lever, the Integral function ensures that the rear wheel is also braked and ABS control remains active for the rear wheel. ABS control for the rear wheel is not deactivated until you depress the footbrake lever.

## Activating ABS function



- Press and hold down ABS button **1**.

 ABS warning light goes out; if self-diagnosis has not completed the ABS warning light changes from ON to flashing.

- When the ABS warning light goes out, release the ABS button within five seconds.
  - » The ABS warning light remains off.
  - » If ABS self-diagnosis did not complete, the ABS warning light continues to flash.

- » The ABS function is activated.
- Instead of pressing the ABS button, you have the option of switching the ignition off and then on again.

 If you switch the ignition off then on again and the ABS light comes back on, there is a fault in the ABS. ◀

## Automatic Stability Control ASC<sup>OE</sup>

### Operating ASC

The ASC pushbutton enables you to change to off-road mode (➔ 86) and to deactivate or reactivate ASC.

ASC is active when the ASC symbol does not show.

 This symbol appears on the display to indicate

that ASC is active in off-road mode.

 This symbol appears on the display to indicate that ASC has been deactivated.

### Three-step sequence of ASC pushbutton operations:

- Switch from ASC to off-road ASC
- Deactivate ASC
- Activate ASC

### Switching and deactivating ASC function

- Switch on the ignition.

 You have the option of deactivating the ASC function while the motorcycle is on the move. ◀



- Press and hold down ASC button **1**.

**S** Off-road ASC symbol shows; if self-diagnosis has not completed the off-road ASC symbol flashes.

- When the off-road ASC symbol appears, release the ASC button within five seconds.

**S** Off-road ASC symbol appears on the display.

- » The off-road ASC function is activated.



- Press and hold down ASC button **1**.

**A** ASC symbol appears on the display.

- When the ASC symbol appears, release the ASC button within five seconds.

**A** ASC symbol continues to show.

- » The ASC function is deactivated.

## Activating ASC function



- Press and hold down ASC button **1**.

**A** ASC symbol no longer shows; if self-diagnosis has not completed the ASC symbol starts flashing.

- When the ASC symbol disappears, release the ASC button within five seconds.
- » The ASC symbol remains off.
- » If ASC self-diagnosis did not complete, the ASC symbol continues to flash.

- » The ASC function is activated.
- Instead of pressing the ASC button, you have the option of switching the ignition off and then on again.

▶ An ASC fault has occurred if the ASC warning light shows when the motorcycle accelerates to a speed in excess of 10 km/h after the ignition was switched off and then on again. ◀

## Emergency off switch (kill switch)



**1** Emergency off switch (kill switch).

**!** Operating the kill switch when riding can cause the rear wheel to lock and thus cause a fall. Do not operate the kill switch when riding. ◀

The emergency off switch is a kill switch for switching off the engine quickly and easily.

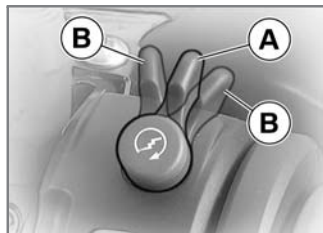

**A** Normal operating position (run)

**B** Engine switched off.

▶ You cannot start the engine unless the kill switch is in the run position. ◀

▶ If you move the kill switch away from the RUN position while the ignition is switched on, the BMW Motorrad Integral ABS remains operational. ◀

## Grip heating<sup>OE</sup>



1 Grip heating switch

The handlebar grips have two-stage heating. Grip heating can be activated only when the engine is running.

▶ The increase in power consumption caused by the grip heating can drain the battery if you are riding at low engine speeds. If the charge level is low, grip heating is switched off to ensure the battery's starting capability.◀



- 2 Heating off.
- 3 50 % heat output (one dot visible)
- 4 100 % heat output (three dots visible)

## Clutch

### Adjusting clutch lever

⚠ If the position of the clutch fluid reservoir is changed, air can enter the clutch system. Do not twist the handlebar fitting or the handlebars.◀

⚠ Attempting to adjust the clutch lever while riding the motorcycle can lead to accidents.

Do not attempt to adjust the clutch lever unless the motorcycle is at a standstill.◀



- Turn adjusting screw 1 clockwise.

▶ The adjusting screw is indexed and is easier to turn if you push the clutch lever forward.◀

» Span between handlebar grip and clutch lever increases.

- Turn adjusting screw **1** counter-clockwise.
- » Span between handlebar grip and clutch lever decreases.

## Brakes

### Adjusting handbrake lever

 Changing the position of the brake-fluid reservoir can allow air to penetrate the brake system.

Do not twist the handlebar fitting or the handlebars. ◀

 Attempting to adjust the brake lever while riding the motorcycle can lead to accidents.

Do not attempt to adjust the brake lever unless the motorcycle is at a standstill. ◀

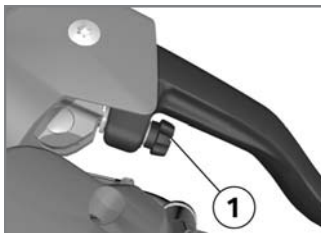

- Turn adjusting screw **1** clockwise.

 The adjusting screw is indexed and is easier to turn if you push the handbrake lever forward. ◀

- » Span between handlebar grip and handbrake lever increases.
- Turn adjusting screw **1** counter-clockwise.
- » Span between handlebar grip and handlebar lever decreases.

### Adjustable footbrake lever

You can adjust the footbrake lever for riding seated or standing on the footrest pegs.



Position of the footbrake lever for riding seated.

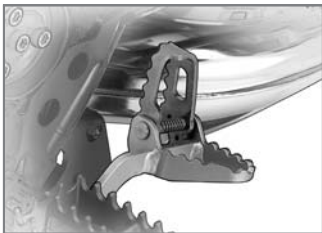

Position of the footbrake lever for riding standing on the pegs.

### Adjusting footbrake lever

- Make sure the ground is level and firm and place the motorcycle on its stand.

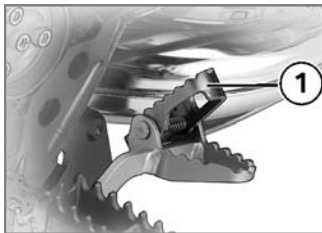

- Push pedal **1** of the brake lever forward and turn it to the correct limit position.
- » The swivel lever engages with an audible click.

## Shift lever

### Adjusting shift lever

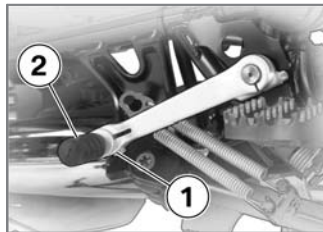

- Slacken screw **1**.
- Turn peg **2** to the desired position.

▶ You might experience difficulties with gear-shifts if the peg is set either too high or too low. If you have difficulties shifting gear consult a specialist workshop, preferably an authorised BMW Motorrad dealer. ◀

- Tighten screw **1** to the specified tightening torque.



Peg to gearshift lever

- 8 Nm

## Lights

### Switching on the side lights

The side lights switch on automatically when the ignition is switched on.

▶ The side lights place a strain on the battery.

Do not switch the ignition on for longer than absolutely necessary. ◀

### Switching on the low-beam headlight

The low-beam headlight switches on automatically when you start the engine.

▶ When the engine is not running you can switch on the lights by switching on the ignition and either switching on the high-beam headlight or operating the headlight flasher. ◀

### Switching on high-beam headlight



- Press the top section of switch **1** for the high-beam headlight.
- » High-beam headlight switched on.

- Move switch **1** for the high-beam headlight to the centre position.
- » High-beam headlight switched off.
- Press the bottom section of switch **1** for the high-beam headlight.
- » The high-beam headlight is switched on until you release the button (headlight flasher).

### Switching on parking lights

- Switch off the ignition.

▶ You can switch on the parking lights only immediately after switching off the ignition. ◀



- Press and hold down switch **1** for the left turn indicators until the parking lights are ON.
  - » Parking lights switched on.

### Switching off parking lights

- Switch the ignition on and then off again.
  - » Parking lights switched off.

### Switching on auxiliary headlights<sup>OE</sup>



- Press the bottom part of switch **1** for the auxiliary headlights.
  - » Auxiliary headlights switched on.

### Switching off auxiliary headlights<sup>OE</sup>



- Press the top part of switch **1** for the auxiliary headlights.
  - » Auxiliary headlights switched off.

## Headlight

### Adjusting headlight for driving on left/driving on right

If the motorcycle is ridden in a country where the opposite rule of the road applies, its asymmetric low-beam headlight will tend to dazzle oncoming traffic.

Have the headlight set accordingly by a specialist workshop, preferably an authorised BMW Motorrad dealer.

### Headlight beam throw and spring preload

Headlight beam throw is generally kept constant when spring preload is adjusted to suit load.

Spring preload adjustment might not suffice only if the motorcycle is very

heavily loaded. Under these circumstances, headlight beam throw has to be adjusted to suit the weight carried by the motorcycle.

▶ Consult a specialist workshop, preferably an authorised BMW Motorrad dealer, if you are unsure whether the headlight basic setting is correct.◀

### Headlight beam-throw adjustment



#### 1 Headlight beam-throw adjustment

Spring preload adjustment might not suffice if the motorcycle is very heavily loaded. Moving the pivot lever adjusts headlight beam throw so as not to dazzle oncoming traffic.

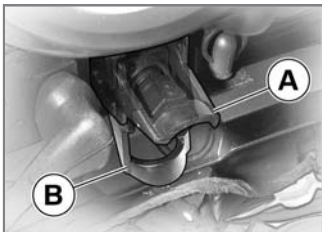

- A** Neutral position  
**B** Position for heavy load

## Turn indicators

### Switching on left flashing turn indicators

- Switch on the ignition.



- Press left-hand turn indicator button **1**.

▶ The turn indicators are cancelled automatically after you have ridden for approximately 10 seconds, or covered a distance of about 200 m. ◀

- » Left-hand turn indicators switched on.
- » Telltale light for left-hand turn indicators flashes.

### Switching on right flashing turn indicators

- Switch on the ignition.

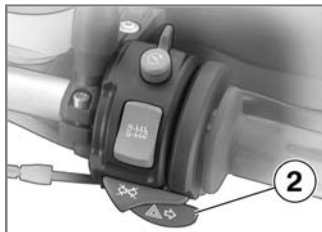

- Press right-hand turn indicator button **2**.

▶ The turn indicators are cancelled automatically after you have ridden for approximately 10 seconds, or covered a distance of about 200 m. ◀

- » Right-hand turn indicators switched on.
- » Telltale light for right-hand turn indicator flashes.

## Cancelling turn indicators



- Press cancel button **3**.
  - » Flashing turn indicators switched off.
  - » Turn indicator telltale light is off.

## Front and rear seats

### Removing rear seat

- Make sure the ground is level and firm and place the motorcycle on its stand.

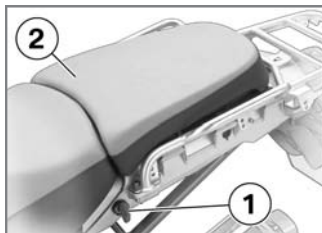

- Turn key **1** clockwise in the seat lock, while pressing down on the front part of rear seat **2**.
- Lift rear seat **2** at the front and remove the seat.

### Install the rear seat

**!** If too much pressure is applied in the forward direction, there is a danger that the motorcycle will be pushed off its stand. Always make sure that the motorcycle is stable and firmly supported.◀

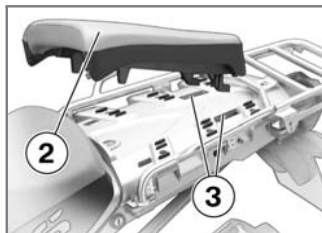

- Engage rear seat **2** in mount **3**.
- Push down firmly on rear seat **2**, applying pressure to the front of the seat.
  - » The rear seat engages with an audible click.

### Remove the front seat

- Make sure the ground is level and firm and place the motorcycle on its stand.
- Removing rear seat (➡ 61)

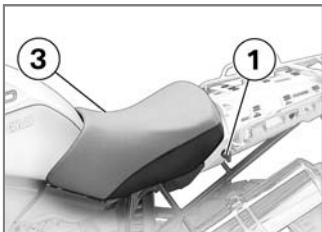

- Turn key **1** counter-clockwise in the seat lock, while pressing down on the rear part of front seat **3**.
- Lift front seat **3** at the rear and remove the seat.

### Install the front seat

**!** If too much pressure is applied in the forward direction, there is a danger that the motorcycle will be pushed off its stand.

Always make sure that the motorcycle is stable and firmly supported. ◀

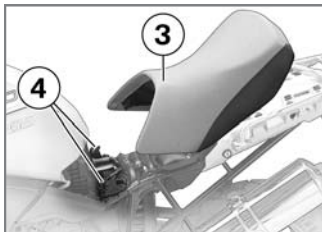

- Engage front seat **3** in mounts **4**.
- Allow the front seat to rest on the motorcycle.
- Applying pressure to the rear of the seat, push the front seat slightly forward and then press the seat firmly down.
- » The front seat engages with an audible click.
- Install the rear seat (➡ 61)

### Adjusting front seat

- Make sure the ground is level and firm and place the motorcycle on its stand.

- Remove the front seat (➡ 61)
- Turn the front seat upside down.

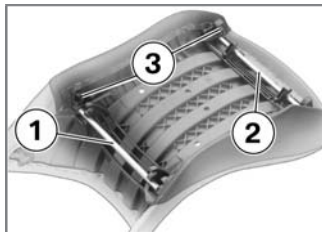

- Introduce seat rods **1** and **2** into holders **3**.

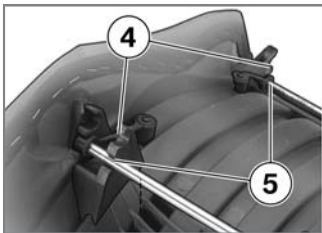

## Helmet holder

### Using helmet holder

- Remove the front seat (⇒ 61)



**!** The helmet catch can scratch the panelling. Make sure the lock is out of the way when you hook the helmet into position.◀

- Attach the helmet to helmet holder **1** by means of the chin strap.
- Install the front seat (⇒ 62)

**!** The front seat can work loose and wobble if the two seat rods are not in the same position.

Always be sure to install both seat rods in the same position.◀

- Introduce the seat rod in position **4**.
- » Seat set to high position.
- Introduce the seat rod in position **5**.
- » Seat set to low position.
- Install the front seat (⇒ 62)

## Mirrors

### Adjusting mirrors



- Pivot the mirror to the correct position by pressing gently at the edge.

## Adjusting mirror arm

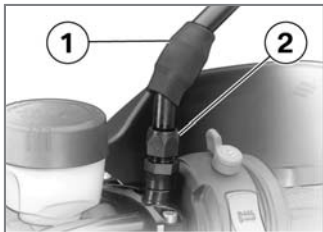

- Push protective cap **1** up over the threaded fastener on the mirror arm.
- Slacken union nut **2**.
- Turn the mirror arm to the appropriate position.
- Retighten union nut **2**.



Mirror to clamping piece

– 25 Nm

- Pull protective cap **1** over the threaded fastener.

## Adjusting windscreen



- Slacken clamping screws **1** on left and right.
- Pivot the windscreen forward or back to the desired position.

 You can set the windscreen to any of several different positions. ◀

- Make sure that clamping screws **1** on left and right are symmetrically positioned.
- Tighten the clamping screws.

## Spring preload

### Spring preload and weight

It is essential to set spring preload of the rear suspension to suit the load carried by the motorcycle. Increase spring preload when the motorcycle is heavily loaded and reduce spring preload accordingly when the motorcycle is lightly loaded.

### Adjusting spring preload for rear wheel



Your motorcycle's handling will suffer if you do not match the spring-preload and damping-characteristic settings. Adjust the damping characteristic to suit spring preload. ◀

 Adjusting spring preload while the motorcycle is being ridden can lead to accidents.

Do not attempt to adjust spring preload unless the motorcycle is at a standstill. ◀

- Make sure the ground is level and firm and place the motorcycle on its stand.

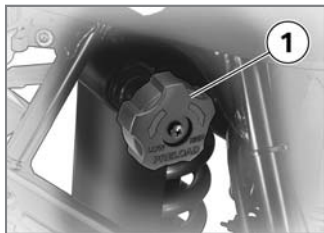

- If you want to increase spring preload, turn knob **1** in the direction indicated by the HIGH arrow.
- If you want to reduce spring preload, turn knob **1** in the

direction indicated by the LOW arrow.

 Rear suspension, spring preload (for riding one-up)

- Turn the knob as far as it will go counter-clockwise in the direction indicated by the LOW arrow (L) and then turn it 10 clicks clockwise

 Rear suspension, spring preload (for off-roading or riding two-up with luggage)

- Turn knob as far as it will go clockwise in the direction indicated by the HIGH arrow (H).

## Spring preload and road-surface condition

It is essential to set spring preload of the front suspension to suit the terrain. Increase spring preload for riding in rough terrain and reduce if the terrain is level.

### Adjusting spring preload for front wheel

- Make sure the ground is level and firm and place the motorcycle on its stand.

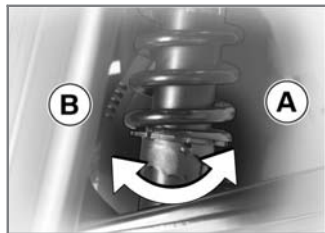

- If you want to reduce spring preload, use the tool from

the on-board toolkit to turn the spring retainer in the **A** direction.

- If you want to increase spring preload, use the tool from the on-board toolkit to turn the spring retainer in the **B** direction.

▶ The range of adjustment comprises five settings.◀



Spring preload at front wheel

- Spring preload at setting 2 (On-road riding)
- Spring preload at setting 3 (For riding on gravel tracks and similar and with load)
- Spring preload at setting 5 (For riding off-road)

## Shock absorbers

### Shock-absorber settings and spring preload

Damping must be adapted to suit spring preload. An increase in spring preload requires firmer damping, a reduction in spring preload requires softer damping.

### Adjusting damping for rear wheel



Your motorcycle's handling will suffer if you do not match the spring-preload and damping-characteristic settings.

Adjust the damping characteristic to suit spring preload.◀

- Make sure the ground is level and firm and place the motorcycle on its stand.

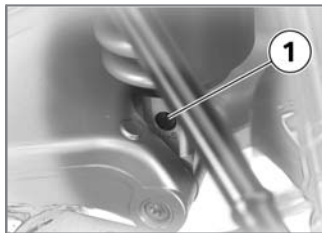

- You adjust the rear shock absorber by turning adjusting screw **1**.

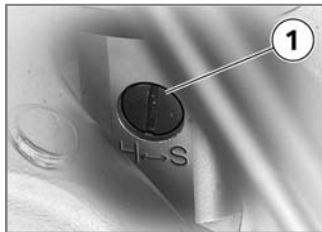

- If you want a harder damping characteristic, use a screwdriver to turn adjust-

ing screw **1** in the direction indicated by the H arrow.

- If you want a softer damping characteristic, use a screwdriver to turn adjusting screw **1** in the direction indicated by the S arrow.



Rear suspension, basic setting

- One-up, rider weighing 85 kg
- Turn the adjusting screw as far as it will go in the direction indicated by the H arrow and then turn it back one and a half turns in the direction indicated by the S arrow.

## Tyres

### Checking tyre pressures



Incorrect tyre pressures impair the motorcycle's handling characteristics and can lead to accidents. Always check that the tyre pressures are correct. ◀



At high road speeds, tyre valves have a tendency to open as a result of centrifugal force.

Fit metal valve caps with rubber seals and screw them on firmly to prevent sudden deflation. ◀



Incorrect tyre pressure reduces the operating life of the tyres.

Always check that the tyre pressures are correct. ◀

- Check tyre pressures against the data below.



Tyre pressure, front

- 2.2 bar (One-up, tyre cold)

- 2.5 bar (Two-up and/or with luggage, tyre cold)



Tyre pressure, rear

- 2.5 bar (One-up, tyre cold)

- 2.9 bar (Two-up and/or with luggage, tyre cold)

If tyre pressure is too low:

- Correct tyre pressure.



## Riding

Safety instructions .....	70
Checklist .....	72
Starting .....	72
Running in .....	75
Riding off-road .....	76
Park your motorcycle .....	77
Refuelling .....	78
Tyre pressure monitoring RDC <sup>OE</sup> .....	80
Brake system, general .....	81
Brake system with BMW Motorrad Integral ABS <sup>OE</sup> .....	82
Electronic engine management with BMW Motorrad ASC <sup>OE</sup> .....	85

## Safety instructions

### Rider's equipment

Do not ride without the correct clothing. Always wear:

- Helmet
- Motorcycling jacket and trousers
- Gloves
- Boots

This applies even to short journeys, and to every season of the year. Your authorised BMW Motorrad dealer will be glad to advise you on the correct clothing for every purpose.

### Speed

If you ride at high speed, always bear in mind that various boundary conditions can adversely affect the handling of your motorcycle:

- Settings of the spring-strut and shock-absorber system
- Imbalanced load
- Loose clothing
- Insufficient tyre pressure
- Poor tyre tread
- Etc.

### Correct loading



Overloading and imbalanced loads can adversely affect the motorcycle's handling.

Do not exceed the permissible gross weight and be sure to comply with the instructions on loading.◀

### Alcohol and drugs



Even small amounts of alcohol or drugs will adversely affect your perception and your ability to assess situations and make decisions, and slow down your

reflexes. Medication can exacerbate these effects.

Do not ride your motorcycle after consuming alcohol, drugs and/or medication.◀

### Risk of poisoning

Exhaust fumes contain carbon monoxide, which is colourless and odourless but highly toxic.



Inhaling the exhaust fumes therefore represents a health hazard and can even cause loss of consciousness with fatal consequences.

Do not inhale exhaust fumes. Do not run the engine in an enclosed space.◀

## High voltage

 Touching live parts of the ignition system with the engine running can cause electric shock.

Do not touch parts of the ignition system when the engine is running. ◀

## Catalytic converter

If misfiring causes unburned fuel to enter the catalytic converter, there is a danger of overheating and damage.

For this reason, observe the following points:

- Do not run the fuel tank dry.
- Do not attempt to start or run the engine with a spark-plug cap disconnected.
- Stop the engine immediately if it misfires.
- Use only unleaded fuel.
- Comply with all specified maintenance intervals.

 Unburned fuel will destroy the catalytic converter.

Note the points listed for protection of the catalytic converter. ◀

## Risk of fire

Temperatures at the exhaust are high.

 Flammable materials (e.g. hay, leaves, grass, clothing and luggage, etc.) could ignite if allowed to come into contact with the hot exhaust pipe.

Do not permit flammable materials to come into contact with the hot exhaust system. ◀

 Cooling would be inadequate if the engine were allowed to idle for a lengthy period with the motorcycle at a standstill: overheating would result.

In extreme cases, the motorcycle could catch fire. Do not allow the engine to idle unnecessarily. Ride away immediately after starting the engine. ◀

## Tampering with the control unit of the electronic engine-management system

 Tampering with the control unit of the electronic engine-management system can damage the motorcycle and cause accidents. Do not tamper with the control unit of the electronic engine-management system. ◀

 Tampering with the control unit of the electronic engine-management system can result in mechanical loads that the motorcycle's com-

ponents are not designed to withstand. Damage caused in this way is not covered by the warranty.

Do not tamper with the control unit of the electronic engine-management system. ◀

## Checklist

Use the following checklist to check important functions, settings and wear limits before you ride off.

- Brakes
- Brake-fluid levels, front and rear
- Clutch
- Clutch fluid level
- Shock absorber setting and spring preload
- Tyre-tread depth and tyre pressures

– Cases correctly installed and luggage secured

At regular intervals:

- Engine oil level (every refuelling stop)
- Brake-pad wear (every third refuelling stop)

## Starting

### Side stand

You cannot start the motorcycle with the side stand extended and a gear engaged. The engine will switch itself off if you start it with the gearbox in neutral and then engage a gear before retracting the side stand.

### Gearbox

You can start the engine when the gearbox is in neutral or if you pull the clutch with a gear engaged. Do not pull the clutch until after you have

switched on the ignition, as otherwise the engine will refuse to start. When the gearbox is in neutral, the green neutral telltale light is on and the gear indicator in the multifunction display shows N.

## Starting engine



- Kill switch in run position **A**.
  - Switch on the ignition.
- » Pre-ride check is performed. (➡ 73)

with OE BMW Motorrad Integral ABS:

- Switch on the ignition.
- » Pre-ride check is performed. (➡ 73)
- » ABS self-diagnosis is performed. (➡ 74)◀

with OE Automatic Stability Control (ASC):

- Switch on the ignition.
- » Pre-ride check is performed. (➡ 73)
- » ABS self-diagnosis is performed. (➡ 74)
- » ASC self-diagnosis is performed. (➡ 74)◀



- Press starter button **1**.

▶ If ambient temperatures are very low, you might find it necessary to open the throttle slightly when starting the engine. At ambient temperatures below 0 °C, disengage the clutch after switching on the ignition.◀

▶ The start attempt is automatically interrupted if battery voltage is too low. Recharge the battery before you start the engine, or use jump leads and a donor battery to start.◀

- » The engine starts.
- » Consult the troubleshooting chart below if the engine refuses to start. (➡ 142)

## Pre-ride check

The instrument cluster runs a test of the 'General' warning light when the ignition is switched on. The warning light shows first red and then yellow, so that you can check that it is in working order. This pre-ride check is indicated by the word CHECK! appearing in the display. The test is aborted if you start the engine before it completes.

### Phase 1

 General warning light lights up red.

- The CHECK! reminder appears on the display.

## Phase 2

 General warning light lights up yellow.

– The CHECK! reminder appears on the display. If the 'General' warning light is not displayed:

 Some malfunctions cannot be indicated if the 'General' warning light cannot be displayed.

Check that the 'General' warning light comes on, and that it lights up yellow and then red. ◀

- Have the fault rectified as quickly as possible by a specialist workshop, preferably an authorised BMW Motorrad dealer.

## ABS self-diagnosis<sup>OE</sup>

BMW Motorrad Integral ABS performs self-diagnosis to ensure its operability. Self-

diagnosis is performed automatically when you switch on the ignition. The motor-cycle has to move forward at a speed above 5 km/h for the wheel sensors to be tested.

### Phase 1

» Test of the diagnosis-compatible system components with the motorcycle at a standstill.

 ABS warning light flashes.

 Possible national variant of the ABS warning light.

### Phase 2

» Test of the wheel sensors as the motorcycle pulls away from rest.

 ABS warning light flashes.

 Possible national variant of the ABS warning light.

## ABS self-diagnosis completed

» The ABS warning light goes out.

If an indicator showing an ABS fault appears when ABS self-diagnosis completes:

- You can continue to ride. Bear in mind that neither the ABS function nor the integral braking function is available.
- Have the fault rectified as quickly as possible by a specialist workshop, preferably an authorised BMW Motorrad dealer.

## ASC self-diagnosis<sup>OE</sup>

BMW Motorrad ASC performs self-diagnosis to ensure its operability. Self-diagnosis is performed automatically

when you switch on the ignition. The engine must be running and the motorcycle must reach a speed of at least 5 km/h in order for ASC self-diagnosis to complete.

### Phase 1

» Test of the diagnosis-compatible system components with the motorcycle at a standstill.



ASC symbol  
slow-flashes.

### Phase 2

» Test of the diagnosis-compatible system components while the motorcycle is on the move.



ASC symbol  
slow-flashes.

## ASC self-diagnosis completed

» The ASC warning light goes out.

If an indicator showing an ASC fault appears when ASC self-diagnosis completes:

- You can continue to ride. Bear in mind that the ASC function is not available.
- Have the fault rectified as quickly as possible by a specialist workshop, preferably an authorised BMW Motorrad dealer.

## Running in

### The first 1000 km

- While running in the motorcycle, vary the throttle opening and engine-speed range frequently.
- Try to do most of your riding during this initial period on twisting, fairly hilly roads,

avoiding high-speed main roads and highways if possible.



Exceeding the specified engine speeds while running in will lead to increased engine wear.

Keep to the specified engine speeds for running in. ◀

- Do not exceed the rpm limits recommended for running in.



Running-in speeds

– <math><4000 \text{ min}^{-1}</math>

- No full-load acceleration.
- Avoid low engine speeds at full load.
- Do not omit the first inspection after 500 - 1200 km.

## Brake pads

New brake pads must "bed down" and therefore do not achieve their optimum friction levels during the first 500 km. You can compensate for this initial reduction in braking efficiency by exerting greater pressure on the levers.

 New brake pads can extend stopping distance by a significant margin. Apply the brakes in good time.◀

## Tyres

New tyres have a smooth surface. This must be roughened by riding in a restrained manner at various heel angles until the tyres are run in. This running in procedure is essential if the tyres are to achieve maximum grip.

 Tyres do not have their full grip when new and there is a risk of accidents at extreme angles of heel. Avoid extreme angles of heel.◀

## Riding off-road

### Tyre pressures

 Tyre pressures reduced for off-road riding impair the motorcycle's handling characteristics on surfaced roads and can lead to accidents. Always check that the tyre pressures are correct.◀

### Dirt or mud on brakes

 When riding on loose surfaces or muddy roads, the brakes may fail to take effect immediately because of dirt or moisture on the discs or brake pads.

Apply brakes in good time until the brakes have been cleaned.◀

 The brake pads will wear more rapidly if you ride frequently on unsurfaced tracks or poor roads. Check the thickness of the brake pads more frequently and replace the brake pads in good time.◀

### Deactivatable ABS<sup>OE</sup>

You can deactivate BMW Integral ABS for off-roading (➡ 50).

### Spring preload and shock-absorber settings

 The off-road settings for spring preload and shock absorber damping characteristic will impair the motorcycle's handling

characteristics on surfaced roads.

If you have been off-roading, remember to correct spring preload and shock-absorber damping characteristics before you return to surfaced roads. ◀

## **Park your motorcycle**

### **Placing motorcycle on side stand**

 If the ground is soft or uneven, there is no guarantee that the motorcycle will rest firmly on the stand. Always check that the ground under the stand is level and firm. ◀

- Switch off the engine.
- Pull the handbrake lever.
- Hold the motorcycle upright and balanced.

- Use your left foot to extend the side stand fully.

 The side stand is designed to support only the weight of the motorcycle. Do not lean or sit on the motorcycle with the side stand extended. ◀

- Slowly lean the motorcycle to the side until its weight is taken by the stand and dismount to the left.

 If the motorcycle is on the side stand, the surface of the ground will determine whether it is better to turn the handlebars to the left or right. However, the motorcycle is more stable on a level surface with the handlebars turned to the left than with the handlebars turned to the right.

On level ground, always turn

the handlebars to the left to set the steering lock. ◀

- Turn the handlebars to full left or right lock.
- Check that the motorcycle is standing firmly.

 On a gradient, the motorcycle should always face uphill; select 1st gear. ◀

- Lock the steering lock.

### **Removing motorcycle from side stand**

- Unlock the steering lock.
- From the left, grip the handlebars with both hands.
- Pull the handbrake lever.
- Swing your right leg over the seat and lift the motorcycle to the upright position.
- Hold the motorcycle upright and balanced.

 An extended side stand can catch on the ground when the motorcycle is moving and lead to a fall.

Retract the side stand before moving the motorcycle. ◀

- Sit on the motorcycle and use your left foot to retract the side stand.

## Placing motorcycle on centre stand

 If the ground is soft or uneven, there is no guarantee that the motorcycle will rest firmly on the stand.

Always check that the ground under the stand is level and firm. ◀

- Switch off the engine.
- Dismount and keep your left hand on the left handlebar grip.

- With your right hand, grip the rear grab handle or the rear frame.
- Place your right foot on the pin of the centre stand, and press the stand down until its curved feet touch the ground.
- Place your full body weight on the centre stand and at the same time pull the motorcycle to the rear.

 Excessive movements could cause the centre stand to retract, and the motorcycle would topple in consequence.

Do not lean or sit on the motorcycle with the centre stand extended. ◀

- Check that the motorcycle is standing firmly.
- Lock the steering lock.

## Removing motorcycle from centre stand

- Unlock the steering lock.
- Place your left hand on the left handlebar grip.
- With your right hand, grip the rear grab handle or the rear frame.
- Push the motorcycle forward off the centre stand.
- Check that the centre stand has fully retracted.

## Refuelling

 Fuel is highly flammable. A naked flame close to the fuel tank can cause a fire or explosion.

Do not smoke. Never bring a naked flame near the fuel tank. ◀

 Fuel expands when hot. Fuel escaping from an overfilled tank could make its

way onto the rear tyre. This could cause a fall. Do not fill the tank past the bottom edge of the filler neck.◀

 Fuel attacks plastics, which become dull or unsightly.

Wipe off plastic parts immediately if they come into contact with fuel.◀

 Fuel can attack the material of the windscreen and the side slipstream deflectors, which become dull or unsightly.

Wipe off the windscreen and slipstream deflectors immediately if they come into contact with fuel.◀

 Leaded fuel will destroy the catalytic converter. Use only unleaded fuel.◀

- Make sure the ground is level and firm and place the motorcycle on its stand.



- Open the protective cap.
- Open the fuel tank cap with the ignition key by turning it counter-clockwise.

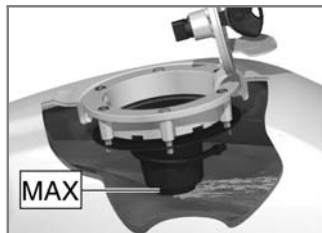



- Refuel with fuel of the grade stated below; do not fill the tank past the bottom edge of the filler neck.

 The ratings for performance and consumption are quoted for the recommended grade of fuel.◀



Recommended fuel grade

– 95 ROZ/RON (Super unleaded)

	Recommended fuel grade
– 91 ROZ/RON (Regular unleaded (fuel grade, usable with power- and consumption-related restrictions))	
	Usable fuel capacity
– 33 l	
	Reserve fuel
– 4 l	

- Press the filler cap down firmly to close.
- Remove the key and close the protective cap.

## Tyre pressure monitoring RDC<sup>OE</sup>

### Function

A sensor integrated into each tyre measures the air temperature and the air pressure inside the tyre and transmits this information to the control unit.

Each sensor has a centrifugal-force tripswitch that does not enable transmission of the measured values until the motorcycle has accelerated to about 30 km/h. The display shows -- for each tyre until the tyre-pressure signal is received for the first time. The sensors continue to transmit the measured-value signals for approximately 15 minutes after the motorcycle comes to a stop.

The control unit can administrate four sensors, so two different sets of wheels with RDC sensors can be alternated on the motorcycle. An error message is issued if wheels without sensors are fitted to a motorcycle equipped with an RDC control unit.

### Temperature compensation

The tyre-pressure readings shown by the multifunction display are temperature-compensated; the reference tyre temperature for these readings is always 20 °C. The air lines available to the public in petrol stations and motorway service areas almost invariably show temperature-dependent tyre pressures, so in most instances these gauge

readings will not tally with the readings shown by the multifunction display.

### **Tyre-pressure ranges**

The RDC control unit differentiates between three air-pressure ranges, all of which are parameterised for the motorcycle:

- Air pressure within permitted tolerance.
- Air pressure close to limit of permitted tolerance.
- Air pressure outside permitted tolerance.

A warning is also issued if tyre pressure drops sharply but stays within the permitted tolerance.

## **Brake system, general**

### **Descending mountain passes**



There is a danger of the brakes fading if you use only the rear brakes when descending mountain passes. Under extreme conditions, the brakes could overheat and suffer severe damage. Use both front and rear brakes, and make use of the engine's braking effect as well.◀

### **Wet brakes**



After the motorcycle has been washed, ridden through water or ridden in the rain, the brake discs and pads might be wet and the brakes might not take effect immediately. Apply the brakes in good time

until the brakes have dried out.◀

### **Salt on brakes**



The brakes may fail to take effect immediately if the motorcycle was ridden on salt-covered roads and the brakes were not applied for some time.

Apply the brakes in good time until the salt layer on the brake discs and brake pads has been removed.◀

### **Oil or grease on brakes**



Oil and grease on the brake discs and pads considerably diminish braking efficiency.

Especially after repair and maintenance work, make sure that the brake discs and brake pads are free of oil and grease.◀

## Dirt or mud on brakes

 When riding on loose surfaces or muddy roads, the brakes may fail to take effect immediately because of dirt or moisture on the discs or brake pads. Apply brakes in good time until the brakes have been cleaned. ◀

 The brake pads will wear more rapidly if you ride frequently on unsurfaced tracks or poor roads. Check the thickness of the brake pads more frequently and replace the brake pads in good time. ◀

## Brake system with BMW Motorrad Integral ABS<sup>OE</sup>

### Partially integral brakes

Your motorcycle is equipped with partially integral brakes. Both front and rear brakes are applied when you pull the handbrake lever. The foot-brake lever acts only on the rear brake.

While the brakes are slowing the motorcycle, the BMW Motorrad Integral ABS adapts braking-force distribution between front and rear brakes to suit the load on the motorcycle.

 The integral braking function makes it very difficult to spin the rear wheel by opening the throttle with the front brake applied to keep the motorcycle stationary (burn-

out). Attempted burn-outs can result in damage to the rear brake and the clutch. Do not attempt burn-outs. ◀

### How does ABS work?

The amount of braking force that can be transferred to the road depends on factors that include the coefficient of friction of the road surface. Loose stones, ice and snow or a wet road all have much lower coefficients of friction than a clean, dry asphalt surface. The lower the coefficient of friction, the longer the braking distance.

If the rider increases braking pressure to the extent that braking force exceeds the maximum transferrable limit, the wheels start to lock and the motorcycle loses its directional stability; a fall is imminent. Before this situation

can occur, ABS intervenes and adapts braking pressure to the maximum transferrable braking force, so the wheels continue to turn and directional stability is maintained irrespective of the condition of the road surface.

### **What are the effects of surface irregularities?**

Humps and surface irregularities can cause the wheels to lose contact temporarily with the road surface; if this happens the braking force that can be transmitted to the road can drop to zero. If the brakes are applied under these circumstances the ABS has to reduce braking force to ensure that directional stability is maintained when the wheels regain contact with the road surface. At this instant the BMW Mo-

torrad Integral ABS must assume an extremely low coefficient of friction, so that the wheels will continue to rotate under all imaginable circumstances, because this is the precondition for ensuring directional stability. As soon as it registers the actual circumstances, the system reacts instantly and adjusts braking force accordingly to achieve optimum braking.

### **What feedback does the rider receive from the BMW Motorrad Integral ABS?**

If the ABS system has to reduce braking force on account of the circumstances described above, vibration is perceptible through the handbrake lever.

When the handbrake lever is pulled, brake pressure is also

built up at the rear wheel by the integral function. If the brake pedal is depressed after the handbrake lever is pulled, the brake pressure built up beforehand is perceptible as counter-pressure sooner than is the case when the brake pedal is depressed either before or at the same time as the brake lever is pulled.

### **How can stopping distance be minimised?**

Each time the brakes are applied, a load distribution shift takes place with the load shifting forward from the rear to the front wheel. The sharper the motorcycle decelerates, the more load is shifted to the front wheel. The higher the wheel load, the more braking force can be

transmitted without the wheel locking.

To optimise stopping distance, apply the front brakes rapidly and keep on increasing the force you apply to the brake lever. This makes the best possible use of the dynamic increase in load at the front wheel. Remember to pull the clutch at the same time. In the "panic braking situations" that are trained so frequently braking force is applied as rapidly as possible and with the rider's full force applied to the brake levers; under these circumstances the dynamic shift in load distribution cannot keep pace with the increase in deceleration and the tyres cannot transmit the full braking force to the surface of the road. ABS has to intervene to keep the front wheel from locking;

this increases stopping distance.

### Rear wheel lift

Even under severe braking, a high level of tyre grip can mean that the front wheel does not lock up until very late, if at all. Consequently, ABS does not intervene until very late, if at all. Under these circumstances the rear wheel can lift off the ground, and the outcome can be a highside situation in which the motorcycle can flip over.



Severe braking can cause the rear wheel to lift off the ground. When you brake, bear in mind that ABS control cannot be relied on in all circumstances to prevent the rear wheel from lifting clear of the ground.◀

### What is the design baseline for BMW Motorrad Integral ABS?

Within the limits imposed by physics, the BMW Motorrad Integral ABS ensures directional stability on any surface. The system is not optimised for special requirements that apply under extreme competitive situations off-road or on the track.

### Special situations

The speeds of the front and rear wheels are compared as one means of detecting a wheel's incipient tendency to lock. If the system registers implausible values for a lengthy period the ABS function is deactivated for safety reasons and an ABS fault message is issued. Self-diagnosis has

to complete before fault messages can be issued. In addition to problems with the BMW Motorrad Integral ABS, exceptional riding conditions can lead to a fault message being issued.

### **Exceptional riding conditions:**

- Heating up with the motorcycle on the centre stand or an auxiliary stand, engine idling or with a gear engaged.
- Rear wheel locked by the engine brake for a lengthy period, for example while descending off-road.

If a fault message is issued on account of exceptional riding conditions as outlined above, you can reactivate the ABS function by switching the ignition off and on again.

## **What significance devolves on regular maintenance?**



Invariably, a technical system cannot perform beyond the abilities dictated by its level of maintenance. In order to ensure that the BMW Motorrad Integral ABS is always maintained in optimum condition, it is essential for you to comply strictly with the specified inspection intervals. ◀

### **Reserves for safety**

The potentially shorter braking distances which BMW Motorrad Integral ABS permits must not be used as an excuse for careless riding. ABS is primarily a means of ensuring a safety margin in genuine emergencies.

Take care when cornering. When you apply the brakes on a corner, the motorcycle's weight and momentum take over and even BMW Motorrad Integral ABS is unable to counteract their effects.

## **Electronic engine management with BMW Motorrad ASC<sup>OE</sup>**

### **How does ASC work?**

The BMW Motorrad ASC compares the speed of rotation of the front wheel and the rear wheel. The differential is used to compute slip as a measure of the reserves of stability available at the rear wheel. If slip exceeds a certain limit the electronic engine management system intervenes, adapting engine torque accordingly.

## What is the design baseline for BMW Motorrad ASC?

BMW Motorrad ASC is designed as an assistant system for the rider and for use on public roads. The extent to which the rider affects ASC control can be considerable (weight shifts when cornering, items of luggage loose on the motorcycle), especially when style of riding takes rider and machine close to the limits imposed by physics.

The off-road mode can be activated for off-roading. This mode delays ASC intervention slightly in order to permit controlled drifting.

The system is not optimised for special requirements that apply under extreme competitive situations off-road or on the track. You have the option of deactivating the

BMW Motorrad ASC system for these circumstances.



Even ASC is constrained by the laws of physics. Invariably, the rider bears responsibility for assessing road and traffic conditions and adopting his or her style of riding accordingly.

Do not take risks that would negate the additional safety offered by this system. ◀

### Special situations

In accordance with the laws of physics, the ability to accelerate is restricted more and more as the angle of heel increases. Consequently, there can be a perceptible lag in acceleration out of very tight bends.

The speeds of the front and rear wheels are compared as one means of detecting a wheel's incipient tendency to spin. If the system registers implausible values for a lengthy period the ASC function is deactivated for safety reasons and an ASC fault message is issued. Self-diagnosis has to complete before fault messages can be issued. The BMW Motorrad ASC can shut down automatically under the exceptional riding conditions outlined below.

### Exceptional riding conditions:

- Riding for a lengthy period with the front wheel lifted off the ground (wheelie).
- Rear wheel rotating with the motorcycle held stationary by applying the front brake (burn-out).

- Heating up with the motorcycle on the centre stand or an auxiliary stand, engine idling or with a gear engaged.

Accelerating the motorcycle to a speed in excess of 10 km/h after switching the ignition off and then on again reactivates the ASC.

Slip can be increased by very-heavy-duty massive-bar tyres, with the result that ASC intervention occurs before optimum forward acceleration is achieved. Under these circumstances, BMW Motorrad ASC should be deactivated.

If the front wheel lifts clear of the ground under severe acceleration, the ASC reduces engine torque until the front

wheel regains contact with the ground.

Under these circumstances, BMW Motorrad recommends rolling the throttle slightly closed so as to restore stability with the least possible delay.

When riding on a slippery surface, never snap the throttle twistgrip fully closed without pulling the clutch at the same time. Engine braking torque can cause the rear wheel to lock, with a corresponding loss of stability. The BMW Motorrad ASC is unable to control a situation of this nature.



## Accessories

General instructions .....	90
Power socket .....	90
Luggage .....	91
Case <sup>OA</sup> .....	92
Topcase <sup>OA</sup> .....	95

## General instructions

BMW Motorrad recommends the use of parts and accessories for your motorcycle that are approved by BMW for this purpose.

Genuine BMW parts and accessories and other products which BMW has approved can be obtained from your authorised BMW Motorrad dealer, together with expert advice on their installation and use.

These parts and products have been tested by BMW for safety, function and suitability. BMW accepts product liability for them.

Conversely, BMW is unable to accept any liability whatsoever for parts and accessories which it has not approved.



BMW Motorrad cannot assess each non-BMW product to determine whether it can be used on or in connection with BMW motorcycles without constituting a safety hazard. Country-specific official authorisation does not suffice as assurance. Tests conducted by these instances cannot make provision for all operating conditions experienced by BMW motorcycles and, consequently, they are not sufficient in some circumstances. Use only parts and accessories approved by BMW for your motorcycle.◀

Whenever you are planning modifications, comply with all the legal requirements. Make sure that the motorcycle does not infringe national road-vehicle construction and use regulations.

## Power socket Ratings



The supply to socket **1** and the extra socket available as an optional accessory (OA) is cut off automatically if battery voltage is low or the load exceeds the maximum permissible amperage.

## Operating electrical accessories

You can start using electrical accessories only when the ignition is switched on. The accessory remains operational

if the ignition is subsequently switched off. In order to ensure that the drain on the on-board power supply system is minimised, the supply to the power socket is cut off approximately 15 minutes after the ignition is switched off, and it is also temporarily interrupted during the start procedure.

## Cable routing

The cables from the power socket to the auxiliary device must be routed in such a way that they:

- do not impede the rider
- do not restrict or obstruct the steering angle and handling characteristics
- cannot be trapped



Incorrectly routed cables can impede the rider.

Route the cables as described above.◀

## Luggage

### Correct loading



Overloading and imbalanced loads can adversely affect the motorcycle's handling.

Do not exceed the permissible gross weight and be sure to comply with the instructions on loading.◀

Fitting a luggage system will affect the handling of your motorcycle. BMW Motorrad recommends limiting top speed to 180 km/h if you ride with cases (OA) and/or topcase (OA) fitted to the motorcycle.

- Set spring preload, damping characteristic and tyre pressures to suit total weight.

- Make sure that the weight is uniformly distributed between right and left.
- Pack heavy items at the bottom and toward the in-board side.
- Max. load in each case (OA), left and right: 10 kg.
- Max. load in topcase (OA): 5 kg.

### Aluminium rubbings

It is advisable to stow sensitive items of luggage in a bag, in order to prevent them from becoming marked by rubbing against the aluminium. BMW Motorrad offers a "watertight bag" as an optional accessory for use with aluminium cases and the aluminium topcase. You can obtain additional information from your authorised BMW Motorrad dealer.

## Set of carry handles

Your authorised BMW Motorrad dealer can supply a "set of carry handles" as an optional accessory to make the cases and topcase easier to carry.

These optional accessories also make good lashing points for items of luggage and the "watertight bag" optional accessory on cases and topcase.

## Case<sup>OA</sup> Opening cases



- Turn key **1** counter-clockwise in the case lock.

▶ You can open the lid of the case at either catch.◀

» The case is unlocked.

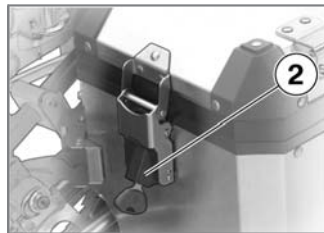

- Pull catch **2** up as far as it will go, while pressing down on the case lid.
- » The catch is open.
- Open the lid.

## Closing cases

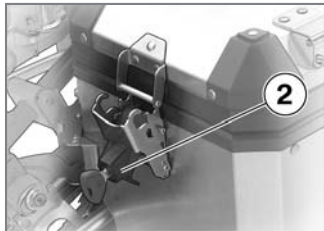

- Push case lid and catch **2** down, engaging the catch hook in the case lid.  
» The catch engages with an audible click.

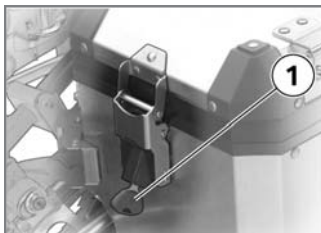

- Turn key **1** clockwise.  
» The case lock is engaged.
- Remove the key.

## Removing case lid

- Open the lid.

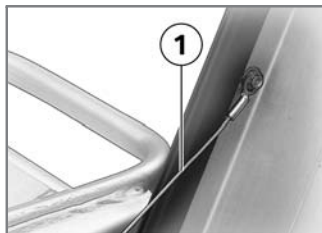

- Disengage retainer **1**.
- Close the case lid.
- Open the second catch of the case lid.
- Remove the case lid.

## Installing case lid

- Place the case lid on the case.
- Close one of the catches.
- Open the lid.

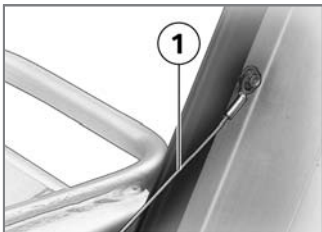

- Engage retainer **1**.
- Close the case lid.

### Removing cases



- Turn key **1** counter-clockwise in the case lock.

» The case is unlocked.

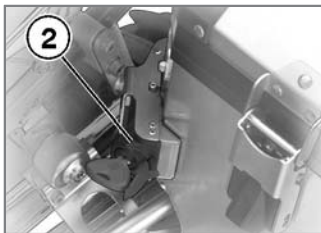

- Push catch **2** in as far as it will go, while holding the case.
- » The catch is open.

**⚠** The left case and the case carrier can become hot on long rides. Allow the case and the case carrier to cool down before removing the case.◀

- Pull the case forward as far as it will go and then out to remove.

### Installing cases

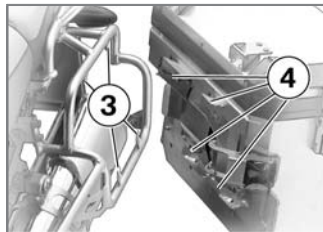

- Position the case on the bottom rail of the case carrier in such a way that hooks **4** are in front of mounts **3**.
- Pivot the case against the top rail, push it back into the mounts and hold it in position.



- Remove the key.

## Topcase<sup>OA</sup>

### Topcase and off-roading

It is advisable to either remove the topcase or fit the backrest cushion available as an optional extra if you intend off-roading.

### Opening topcase

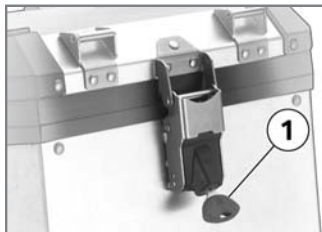

- Turn key **1** counter-clockwise.  
» The topcase is unlocked.

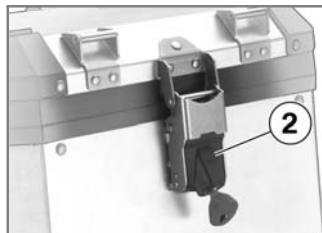

- Pull catch **2** up as far as it will go, while pressing down on the topcase lid.  
» The catch is open.  
• Open the topcase lid.

### Closing topcase

- Close the topcase lid.

- Press catch **2** out as far as it will go.  
» The catch engages with an audible click.



- Turn key **1** clockwise.  
» The case lock is engaged.

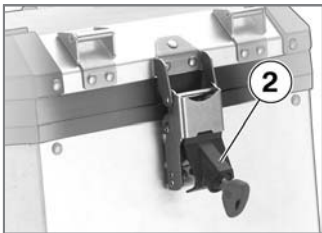

- Push topcase lid and catch **2** down, engaging the catch hook in the topcase lid.
- » The catch engages with an audible click.

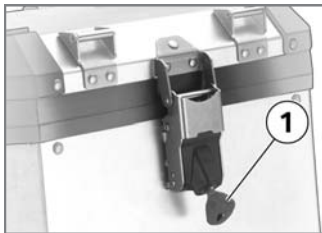

- Turn key **1** clockwise.
- » The topcase is locked.
- Remove the key.

### Removing topcase



- Turn key **1** counter-clockwise.

» The topcase is unlocked.



- Press catch **2** down as far as it will go.

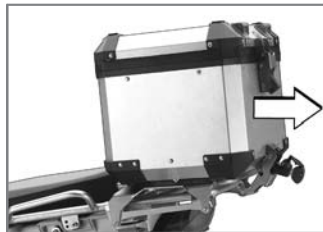

- Pull the topcase back as far as it will go and then lift it up to remove.

## Installing topcase

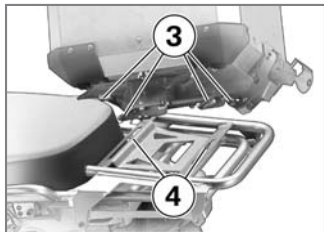

- Position the topcase on the topcase mount in such a way that hooks **3** are just behind rails **4**.

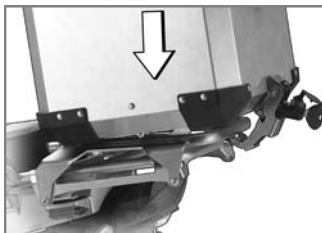

- Press the topcase down until it is seated flat on the topcase carrier.

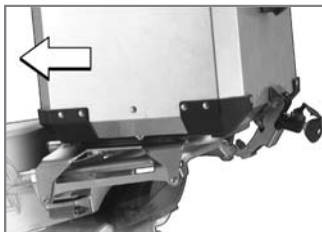

- Push the topcase forward as far as it will go, taking care not to push the motor-

cycle forward off its centre stand.



- Push catch **2** up.  
» The catch engages with an audible click.



- Turn key **1** clockwise.

- » The topcase is locked.
- Remove the key.

## Adjustable topcase mount

The topcase mount can be installed on the luggage carrier or instead of the rear seat.

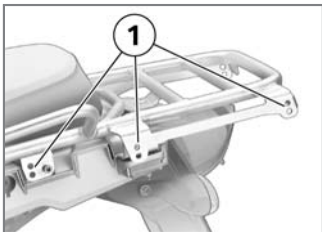

The luggage carrier has two sets of holes, one above the other, at locations **1**. The topcase mount can be tilted forward or back by using holes at different heights front and back. This enables the topcase to be used as a back-

rest in combination with the topcase cushion available as an optional accessory.

## Repositioning topcase mount

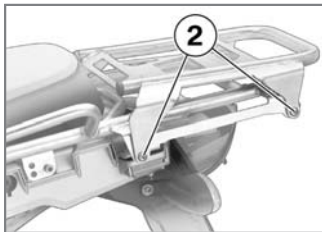

- Remove screws **2** on left and right.
- Removing rear seat (➔ 61)

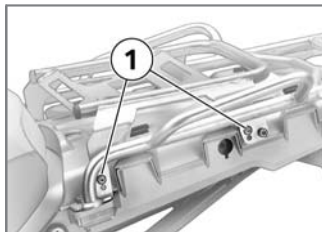

- Install the topcase mounts at the desired angle in holes **1**.
- Install the rear seat (➔ 61)

## Maintenance

General instructions .....	100	Jump start .....	129
Toolkit .....	100	Battery .....	131
Engine oil .....	102		
Brake system, general .....	103		
Brake pads .....	104		
Brake fluid .....	106		
Clutch .....	108		
Tyres .....	109		
Rims .....	109		
Wheels .....	110		
Front-wheel stand .....	116		
Bulbs .....	117		
Air filter .....	126		
Removing right side panel .....	129		
Installing right side panel .....	129		

## General instructions

The Maintenance chapter describes straightforward procedures for checking and replacing certain wear parts. Special tightening torques are listed as applicable. The tightening torques for the threaded fasteners on your motorcycle are listed in the section entitled "Technical data".

You will find information on more extensive maintenance and repair work in the Repair Manual on DVD/CD-ROM (RepROM) for your motorcycle, which is available from your authorised BMW Motorrad dealer.

Some of the work calls for special tools and a thorough knowledge of motorcycles. If you are in doubt consult a specialist workshop, prefer-

ably your authorised BMW Motorrad dealer.

## Toolkit

### Standard on-board toolkit

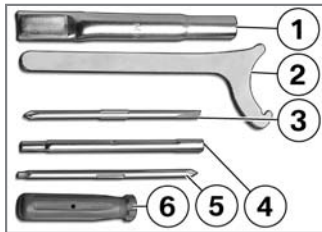

#### 1 Extension

- For use with hook wrench

#### 2 Hook wrench

- Adjusting spring preload, front

#### 3 Screwdriver blade, cross-head/plain

- Removing and installing turn indicator glass
- Replacing rear-light/brake-light bulbs
- Disconnecting leads from battery terminals
- Adjusting rear suspension damping

#### 4 Extension for screwdriver blade

- Adjusting damping for rear wheel

#### 5 Screwdriver blade, cross-head/TORX T25

- Replacing air filter

#### 6 Screwdriver handle

- Adapter for screwdriver blades

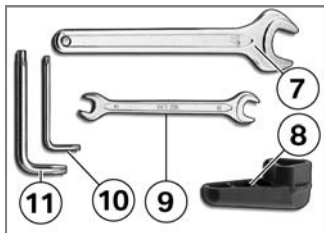

### 11 TORX wrench, T30

- Replacing bulbs for auxiliary headlights

### On-board toolkit service kit

Your authorised BMW Motorrad dealer can provide the on-board toolkit service kit that you will need if you are considering undertaking more extensive work.

You will find information on undertaking work of this nature in the Repair Manual on the DVD/CD-ROM also obtainable from your authorised BMW Motorrad dealer.

### 7 Open-ended spanner, w/f 17

- Adjust the mirror arm

### 8 Tool for oil cap

- Opening and closing cap of oil filler neck

### 9 Open-ended spanner, w/f 8/10

- Replacing bulbs for auxiliary headlights

### 10 TORX wrench, T15

- Replacing bulbs for auxiliary headlights

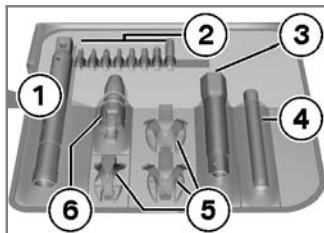

### 1 extending tool holder

- Adapters to accommodate all tools
- Removing and installing spark plugs

### 2 1/4" bits

- 5x Torx, for example for removing and installing rear wheel
- 2x cross-head bits
- 1x plain screwdriver bit

### 3 3/8" adapter for socket-head screws, w/f 22

- Removing and installing front axle

#### 4 Electric torch

- LED bulb

#### 5 Socket

- 3x open-ended spanner, for example for connecting and disconnecting leads to battery terminals

#### 6 Adapter

- Adapter for 1/4" bits
- 9x12 mm and 3/8" swivel adapters

## Engine oil

### Checking engine oil level

 The engine can seize if the oil level is low, and this can lead to accidents.

Always make sure that the oil level is correct. ◀

 The oil level varies with the temperature of the oil. The higher the temperature, the higher the level of

oil in the sump. Checking the oil level with the engine cold or after no more than a short ride will lead to misinterpretation; this in turn, means that the engine will be operated with the incorrect quantity of oil.

In order to ensure that the engine oil level is read correctly, check the oil level only after a lengthy trip. ◀

 The insufficient oil pressure warning does not fulfil the function of an oil gauge. The only way of checking whether the oil level is correct is to check the oil sight glass. ◀

- Hold the motorcycle upright or place it on its centre stand.
- Wait five minutes after switching off the engine at operating temperature.

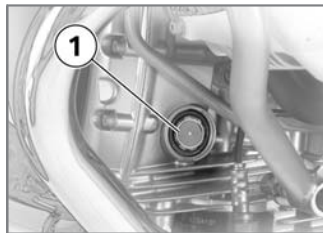

- Check the oil level in oil sight glass **1**.

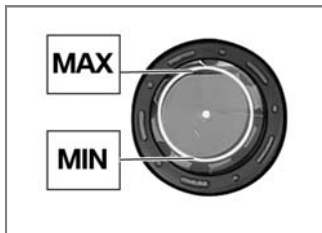

 Engine oil, specified level  
– between MIN and MAX marks

## Topping up the engine oil

- Checking engine oil level (➔ 102)

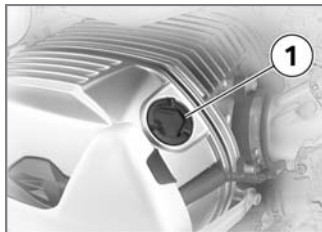

 Damage to the engine can result if it is operated without enough oil, but the same also applies if the oil level is too high. Always make sure that the oil level is correct.◀

- Wipe the area around the filler neck clean.
- Use the tool from the toolkit to remove cap **1** from the engine oil filler neck.

If the oil level is below the MIN mark:

- Top up the engine oil.

If the oil level is above the MAX mark:

- Have the fault rectified by a specialist workshop, preferably an authorised BMW Motorrad dealer.

- Top up the engine oil to the specified level.
- Install the cap of the oil filler neck.

## Brake system, general Dependability of the brake system

A fully functional brake system is a basic requirement for the road safety of your motorcycle.

Do not ride the motorcycle if you have any doubts about the dependability of the brake system.

Under these circumstances have the brake system checked by a specialist workshop, preferably an authorised BMW Motorrad dealer.

**⚠** Incorrect working practices endanger the reliability of the brakes. Have all work on the brake system performed by a specialist workshop, preferably an authorised BMW Motorrad dealer. ◀

### Checking operation of the brakes

- Pull the handbrake lever.
    - » The pressure point must be clearly perceptible.
  - Press the footbrake lever.
    - » The pressure point must be clearly perceptible.
- If pressure points are not clearly perceptible:
- Have the brakes checked by a specialist workshop, preferably an authorised BMW Motorrad dealer.

## Brake pads

### Check brake-pad thickness, front brakes

**⚠** Brake pads worn past the minimum permissible thickness can cause a reduction in braking efficiency and under certain circumstances they can cause damage to the brake system.

- In order to ensure the dependability of the brake system, do not permit the brake pads to wear past the minimum permissible thickness. ◀
- Make sure the ground is level and firm and place the motorcycle on its stand.



- Visually inspect the left and right brake pads to ascertain their thickness. Viewing direction: Between wheel and fork tube toward the brake caliper.

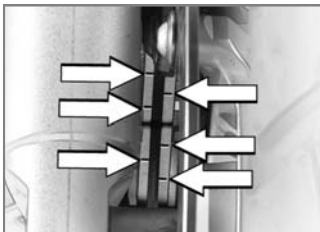

 Brake-pad thickness, front

- The wear indicators (arrows) must be clearly visible on each brake pad.

If the wear indicating mark is no longer clearly visible:

- Have the brake pads replaced by a specialist workshop, preferably an authorised BMW Motorrad dealer.

## Check brake pad thickness, rear brakes

 Brake pads worn past the minimum permissible thickness can cause a reduction in braking efficiency and under certain circumstances they can cause damage to the brake system.

In order to ensure the dependability of the brake system, do not permit the brake pads to wear past the minimum permissible thickness. ◀

- Make sure the ground is level and firm and place the motorcycle on its stand.



- Visually inspect brake pads **1** from the left to ascertain their thickness.

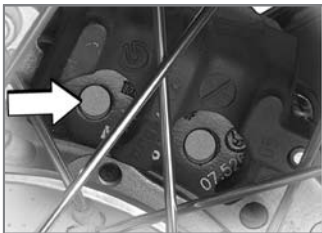

Brake-pad thickness,  
rear

- Make sure that the brake disc is not visible through the bore in the inboard brake block.

If the brake disc is visible:

- Have the brake pads replaced by a specialist workshop, preferably an authorised BMW Motorrad dealer.

## Brake fluid

### Check the brake-fluid level, front brakes



A low fluid level in the brake reservoir can allow air to penetrate the brake system. This significantly reduces braking efficiency.

Check the brake-fluid level at regular intervals. ◀

- Make sure the ground is level and firm and place the motorcycle on its stand.
- Move the handlebars to the straight-ahead position.

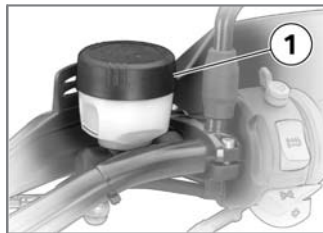

- Check the brake fluid level in front reservoir **1**.



The brake fluid level in the brake fluid reservoir drops as the brake pads wear. ◀



## Check the brake-fluid level, rear brakes

**!** A low fluid level in the brake reservoir can allow air to penetrate the brake system. This significantly reduces braking efficiency. Check the brake-fluid level at regular intervals. ◀

- Make sure the ground is level and firm and place the motorcycle on its centre stand.

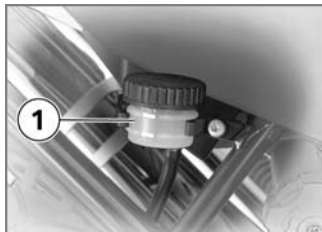

- Check the brake fluid level in reservoir **1**.

▶ The brake fluid level in the brake fluid reservoir drops as the brake pads wear. ◀

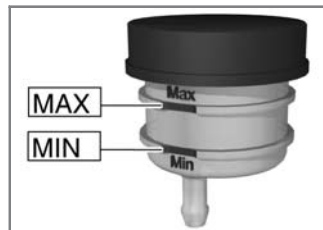

 Brake fluid level, rear

– DOT4 brake fluid

– Do not permit the brake fluid level to drop below the MIN mark. (Brake-fluid reservoir horizontal)

 Brake fluid level, front

– DOT4 brake fluid

– Do not permit the brake fluid level to drop below the MIN mark. (Brake-fluid reservoir horizontal)

If the brake fluid level drops below the permitted level:

- Have the defect rectified as quickly as possible by a specialist workshop, preferably an authorised BMW Motorrad dealer.

If the brake fluid level drops below the permitted level:

- Have the defect rectified as quickly as possible by a specialist workshop, preferably an authorised BMW Motorrad dealer.

## Clutch

### Checking clutch operation

- Pull the clutch lever.
  - » The pressure point must be clearly perceptible.

If the pressure point is not clearly perceptible:

- Have the clutch checked by a specialist workshop, preferably an authorised BMW Motorrad dealer.

### Checking the clutch fluid level

- Make sure the ground is level and firm and place the motorcycle on its stand.
- Move the handlebars to the straight-ahead position.

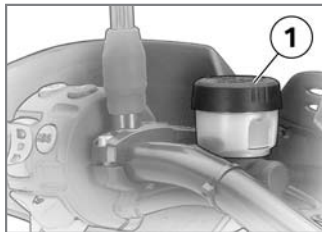

- Check the clutch fluid level in reservoir **1**.

▶ Wear of the clutch causes the fluid level in the clutch fluid reservoir to rise. ◀



Clutch fluid level

- Do not permit the clutch fluid level to drop. (motorcycle upright and handlebars in straight-ahead position)

If the fluid level drops:



Unsuitable hydraulic fluids could cause damage to the clutch system.

Do not attempt to top up the system with fluids of any kind. ◀

- Have the defect rectified as quickly as possible by a specialist workshop, preferably an authorised BMW Motorrad dealer.

 The clutch system is filled with a special hydraulic fluid that does not have to be changed.◀

## Tyres

### Checking tyre tread depth

 Your motorcycle's handling and grip can be impaired even before the tyres wear to the minimum tyre tread depth permitted by law. Have the tyres changed in good time before they wear to the minimum permissible tread depth.◀

- Make sure the ground is level and firm and place the motorcycle on its stand.
- Measure the tyre tread depth in the main tread grooves with wear marks.

 Tyres have wear indicators integrated into the main tread grooves. The tyre is worn out when the tyre tread has worn down to the level of the marks. The locations of the marks are indicated on the edge of the tyre, e.g. by the letters TI, TWI or by an arrow.◀

If the tyre tread is worn to minimum:

- Replace tyre or tyres, as applicable.

## Top speed

 The motorcycle's top speed might be higher than the maximum speed permitted for the tyres. Excessive speeds can damage the tyres and this could cause accidents.

Comply with the tyre-specific speed restrictions.◀

Always bear the maximum permissible top speed of the tyres in mind when riding a motorcycle fitted with massive-bar tyres.

Affix a label stating the maximum permissible speed in the rider's field of vision.

## Rims

### Checking rims

- Make sure the ground is level and firm and place the motorcycle on its stand.

- Visually inspect the rims for defects.
- Have damaged rims checked and, if necessary, replaced by a specialist workshop, preferably an authorised BMW Motorrad dealer.

### Check the spokes

- Make sure the ground is level and firm and place the motorcycle on its stand.
- Draw the handle of a screwdriver or a similar instrument across the spokes and listen to the notes of the individual spokes.

If the notes vary:

- Have the spokes checked by a specialist workshop, preferably an authorised BMW Motorrad dealer.

## Wheels

### Approved wheels and tyres

For each size of tyre BMW Motorrad tests certain makes, and approves those that it certifies as roadworthy. If BMW Motorrad has not approved the wheels and tyres, it cannot assess their suitability or provide any guarantee of road safety.

Use only wheels and tyres approved by BMW Motorrad for your type of motorcycle. You can obtain detailed information from your authorised BMW Motorrad dealer or on the Internet at [www.bmw-motorrad.com](http://www.bmw-motorrad.com).

## RDC label<sup>OE</sup>

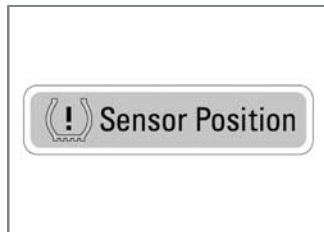

 Incorrect tyre-removal procedures can result in damage to the RDC sensors. Be sure to notify the authorised BMW Motorrad dealer or specialist workshop that the wheel is fitted with an RDC sensor. ◀

If the motorcycle is equipped with RDC, each wheel rim bears an adhesive label indicating the position of the RDC sensor. When changing the tyre, take care not to damage the RDC sensor. Be sure to

draw the attention of the authorised BMW Motorrad dealer or specialist workshop to the fact that the wheel is fitted with an RDC sensor.

## Removing front wheel

- Make sure the ground is level and firm and place the motorcycle on its centre stand or the auxiliary stand.  
with OE BMW Motorrad Integral ABS:

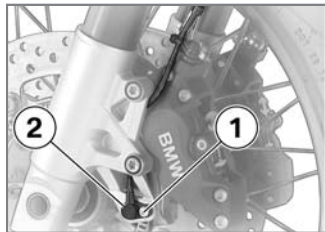

- Remove securing screw **1** of the ABS sensor from below the left brake caliper.

- Withdraw ABS sensor **2** from its bore.◀

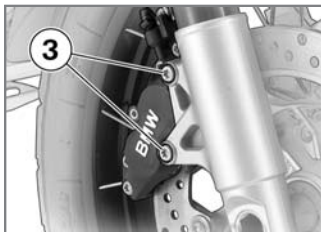

**!** Once the calipers have been removed, there is a risk of the brake pads being pressed together to the extent that they cannot be slipped back over the brake disc on reassembly. Do not operate the handbrake lever when the brake calipers have been removed.◀

- Remove securing screws **3** of the brake calipers on left and right.

with OE BMW Motorrad Integral ABS:

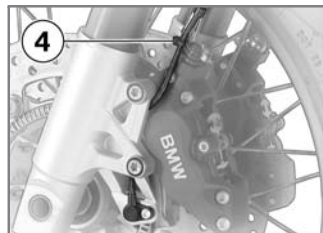

- When removing the left brake caliper, take care not to damage ABS sensor cable **4**.◀
- Mask off the parts of the wheel rim that could be scratched in the process of removing the brake calipers.

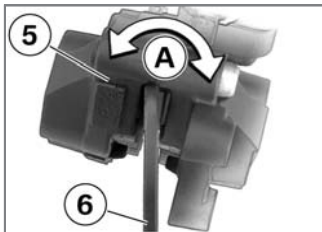

- Force the brake pads slightly apart by rocking brake calipers **5** back and forth **A** against brake discs **6**.
- Carefully pull the brake calipers back and out until clear of the brake discs.



- Lift the front of the motorcycle on the front wheel stand (363971) or a suitable auxiliary stand until the front wheel is clear to turn. BMW Motorrad recommends the BMW Motorrad front wheel stand.
- Install the front wheel stand.

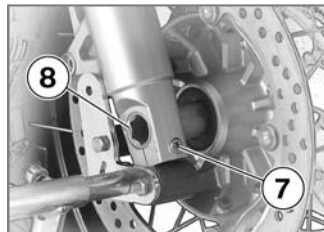

- Remove axle clamping screw **7**.
- Remove quick-release axle **8**, holding the wheel as you do so.

▶ BMW Motorrad provides an adapter for removing the quick-release axle. This adapter can be combined with a commercially available w/f 22 open-end or ring spanner. The BMW special tool number is 36 3 691 and the adapter is available from your authorised BMW Motorrad dealer.◀

- Lower the front wheel to the ground between the front forks.
- Roll the front wheel forward to remove.



- Remove spacing bushing **9** from the front-wheel hub.

### Installing front wheel

**!** Threaded fasteners not tightened to the specified torque can work loose or their threads can suffer damage.

Always have the security of the fasteners checked by a

specialist workshop, preferably an authorised BMW Motorrad dealer. ◀

**!** There is a risk of damaging parts of the front brake, particularly the BMW Integral ABS, in the course of the procedure described below.

Take care not to damage the brake system, in particular the ABS sensor with cable and the ABS sensor ring. ◀

**!** The front wheel must be installed right way round to rotate in the correct direction.

Note the direction-of-rotation arrows on the tyre or the wheel rim. ◀

- When installing the wheel, take care not to damage brake pipes, brake discs, brake pads and the rim.

with OE BMW Motorrad Integral ABS:

- When installing the wheel, take care not to damage the ABS sensor cable, the ABS sensor ring and the ABS sensor. ◀



- Install spacing bushing **9** in the wheel hub.
- Roll the front wheel into position between the front forks.

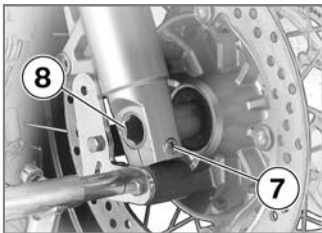

- Raise the front wheel, install quick-release axle **8** and tighten to specified tightening torque.



Quick-release axle in axle holder

– 50 Nm

- Tighten axle clamping screw **7** to the specified torque.



Quick-release axle clamp screws

– 19 Nm

- Remove the front wheel stand.

with OE BMW Motorrad Integral ABS:

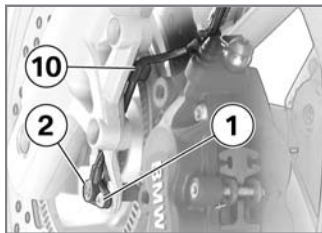

- Insert ABS sensor **2** into its bore and install screw **1**.



The cable of the ABS sensor could chafe through if it comes into contact with the brake disc. Make sure that the ABS sensor cable is routed correctly. ◀

- Clip the ABS sensor cable into clip **10** to make sure it remains correctly routed. ◀
- Ease the brake calipers on to the brake discs.

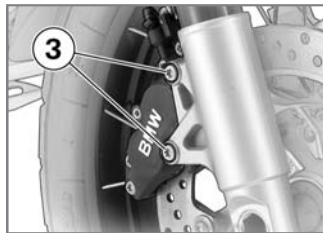

- Install securing screws **3** on left and right and tighten to specified tightening torque.



Brake caliper to slider tube

– 30 Nm

- Remove the adhesive tape from the wheel rim.

 Braking efficiency is impaired if the brake pads are not correctly bedded against the discs.

Before riding off, always check that the brakes bite as soon as the brake lever is pulled or the brake pedal depressed.◀

- Firmly pull the handbrake lever several times.  
» The pressure point must be clearly perceptible.

with OE BMW Motorrad Integral ABS:

- Switch on the ignition.
- Wait for ABS self-diagnosis to complete.
- Firmly pull the handbrake lever several times.  
» The pressure point must be clearly perceptible.◀

## Removing rear wheel

- Make sure the ground is level and firm and place the motorcycle on its centre stand or the auxiliary stand.
- Engage first gear.

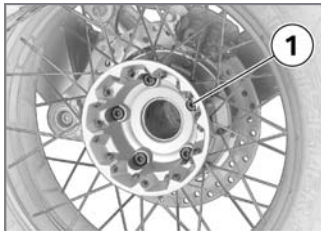

 Parts of the exhaust system can be hot.

Do not touch hot parts of the exhaust system.◀

- Remove studs **1** from the rear wheel, holding the wheel as you do so.
- Roll the rear wheel out toward the rear.

## Installing rear wheel

 Threaded fasteners not tightened to the specified torque can work loose or their threads can suffer damage.

Always have the security of the fasteners checked by a specialist workshop, preferably an authorised BMW Motorrad dealer.◀

- Roll the rear wheel into position at the rear-wheel adapter.
- Seat the rear wheel on the rear-wheel adapter.

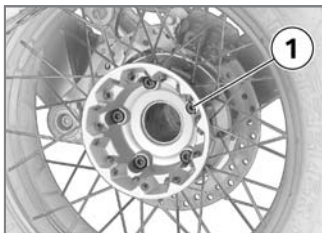

- Tighten wheel studs **1** until hand-tight and then tighten to specified torque in diagonally opposite sequence.



Rear wheel to wheel carrier

– Tightening sequence:  
Tighten in diagonally opposite sequence

– 60 Nm

## Front-wheel stand

### Use

A front-wheel stand for simple, safe changing of the front wheel is available from BMW Motorrad. The BMW special tool number is 36 3 970 and the front-wheel stand is available from your authorised BMW Motorrad dealer.



The BMW Motorrad front wheel stand is not designed to support motorcycles not fitted with a centre stand or without other auxiliary stands. A motorcycle resting only on the front wheel stand and the rear wheel can topple.

Place the motorcycle on its centre stand or another auxiliary stand before lifting the

front wheel with the BMW Motorrad front-wheel stand. ◀

### Fitting front wheel stand

- Make sure the ground is level and firm and place the motorcycle on its centre stand or the auxiliary stand.

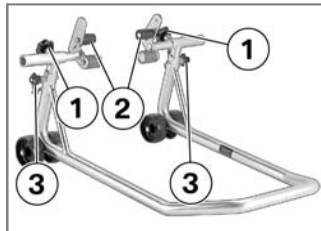

- Slacken adjusting screws **1**.
- Push the two adapters **2** apart until the front forks fit between them.
- Use locating pins **3** to set the front wheel stand to the desired height.

- Centre the front wheel stand relative to the front wheel and push it against the front axle.

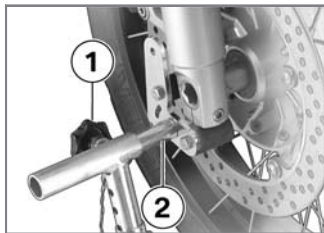

- Align the two adapters **2** so that the front forks are securely seated.
- Tighten adjusting screws **1**.



**!** If the motorcycle is on the centre stand and is raised too far, the centre stand will lift clear of the ground and the motorcycle could topple to one side. When raising the motorcycle, make sure that the centre stand remains on the ground. ◀

- Apply uniform pressure to push the front wheel stand down and raise the motorcycle.

## Bulbs

### General instructions

A warning appears in the multifunction display if a bulb is defective. If the brake light or rear light fails, the warning is accompanied by the General warning light lighting up yellow. If the rear light fails the second filament of the brake light shines at reduced brightness to double as a rear light. Even though you have this substitute rear light, the indicators in the display tell you that a bulb defect has occurred.

**!** A defective bulb places your safety at risk because it is easier for other users to oversee you and your motorcycle. Replace defective bulbs as soon as possible; always

carry a complete set of spare bulbs if possible. ◀

 The bulb is pressurised and can cause injury if damaged.

Wear protective goggles and gloves when changing bulbs. ◀

 The types of bulb fitted to your motorcycle are listed in the section entitled "Technical data". ◀

 Do not touch the glass of new bulbs with your fingers. Use a clean, dry cloth to hold the bulbs when handling them. Dirt deposits, in particular oil and grease, interfere with heat radiation from the bulb. This leads to overheating and shortens the bulb's operating life. ◀

## Replace the low-beam and high-beam headlight bulb

 If it is not standing firmly, the motorcycle could topple in the course of the operations described below. Always make sure that the motorcycle is stable and firmly supported. ◀

- Make sure the ground is level and firm and place the motorcycle on its stand.
- Switch off the ignition.
- Turning handlebars all the way to the left

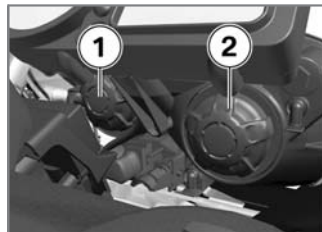

- Turn cover **1** for low-beam headlight counter-clockwise and remove it.
- Turn cover **2** for high-beam headlight counter-clockwise and remove it.

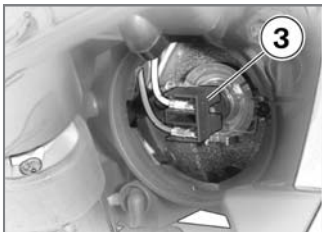

- Disconnect plug **3**.

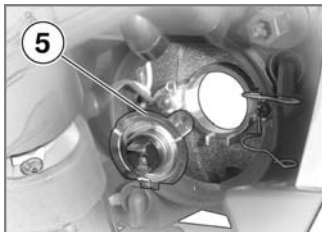

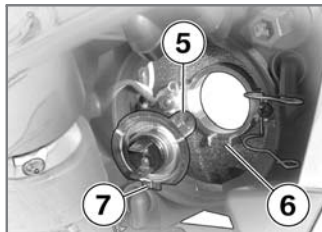

- Remove bulb **5**.
- Replace the defective bulb.

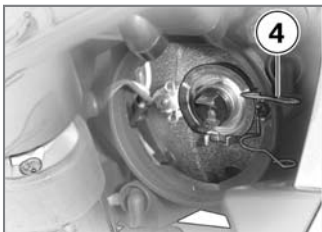

- Install bulb **5** with tab **7** in guide **6**.



- Release spring clips **4** at top and bottom and swing them aside.

	Low-beam headlight bulb
- H7 / 12 V / 55 W	
	High-beam headlight bulb
- H7 / 12 V / 55 W	



- Engage spring clip **4** in the catch.

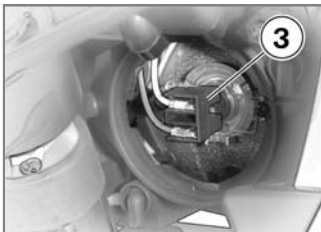

- Install plug **3**.

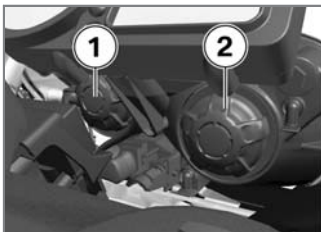

- Turn cover **1** for low-beam headlight clockwise to install. Make sure that the wording TOP is at the top.
- Turn cover **2** for high-beam headlight clockwise to in-

stall. Make sure that the wording TOP is at the top.

## Replacing parking-light bulb



If it is not standing firmly, the motorcycle could topple in the course of the operations described below. Always make sure that the motorcycle is stable and firmly supported. ◀

- Make sure the ground is level and firm and place the motorcycle on its stand.
- Switch off the ignition.
- Turn the handlebars all the way to the right

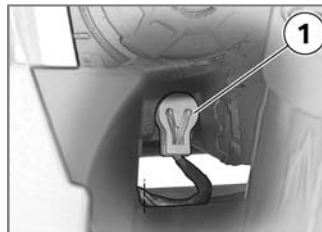

- Pull bulb carrier **1** out of the headlight housing.
- Remove the bulb from the bulb socket.
- Replace the defective bulb.



Parking-light bulb

– W5W / 12 V / 5 W

- Install the bulb in the bulb socket.

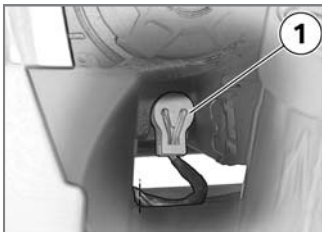

- Install bulb carrier **1** in the headlight housing.

## Replacing brake light and rear light bulb

 If it is not standing firmly, the motorcycle could topple in the course of the operations described below. Always make sure that the motorcycle is stable and firmly supported. ◀

- Make sure the ground is level and firm and place the motorcycle on its stand.

- Switch off the ignition.

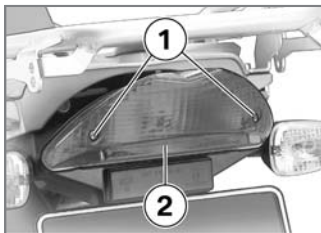

- Remove screws **1**.
- Pull bulb housing **2** to the rear until it is clear of the holders.

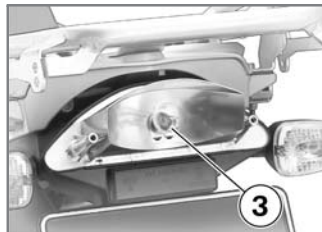

- Press bulb **3** into its socket and turn it counter-clockwise to remove.
- Replace the defective bulb.

 Bulb of tail light/brake light

– P21/5W / 12 V / 5 W / 21 W

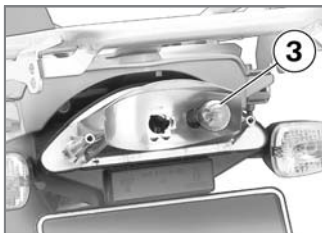

- Press bulb **3** into its socket and turn it clockwise to install.

▶ There is only one position in which the bulb can be inserted into the socket. ◀

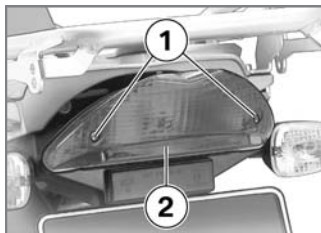

- Seat bulb housing **2** in its holders.
- Install screws **1**.

### Replacing turn indicator bulbs, front and rear

**!** If it is not standing firmly, the motorcycle could topple in the course of the operations described below. Always make sure that the motorcycle is stable and firmly supported. ◀

- Make sure the ground is level and firm and place the motorcycle on its stand.



- Remove screw **1**.

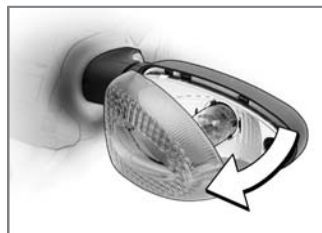

- Pull the glass out of the reflector housing at the threaded-fastener side.

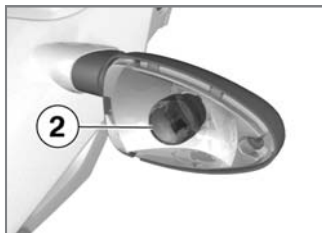

- Turn bulb **2** counter-clockwise and remove it from the bulb housing.
- Replace the defective bulb.

 Front flashing turn indicator bulbs

– R10W / 12 V / 10 W

with OE White turn indicators:

– RY10W / 12 V / 10 W◁



 Rear flashing turn indicator bulbs

– R10W / 12 V / 10 W

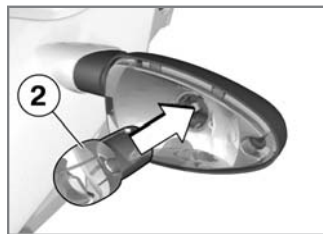

 Rear flashing turn indicator bulbs

with OE White turn indicators:

– RY10W / 12 V / 10 W◁

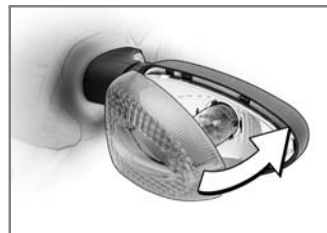

- Turn bulb **2** clockwise to install it in the bulb housing.



- Working from the inboard side, insert the glass into the bulb housing and close the housing.



- Install screw **1**.

## Replacing auxiliary headlights<sup>OE</sup>

**!** If it is not standing firmly, the motorcycle could topple in the course of the operations described below. Always make sure that the motorcycle is stable and firmly supported. ◀

- Make sure the ground is level and firm and place the motorcycle on its stand.

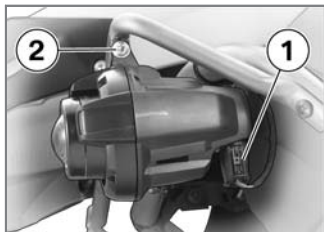

- Disconnect plug **1**.
- Slacken screw **2**.

- Pivot the headlight lens forward.



- Remove four screws **3**.
- Push bulb cover **4** down to remove.



- Pull bulb housing **5** down until it is clear of the holder.



- Turn bulb **6** counter-clockwise to remove.
- Replace the defective bulb.



Auxiliary headlight  
bulbs

with OE Supplement-  
ary headlight:

- H11 / PGJ 19-2 / 12 V /  
55 W<



- Push bulb housing **5** up into the holder from below.



- Seat bulb cover **4** from below.
- Install four screws **3**.

- Pivot the headlight lens back.

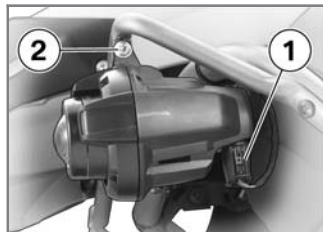

- Tighten screw **2**.
- Connect plug **1**.
- Adjust the headlight so that it does not dazzle oncoming traffic.

### Replacing fuses for auxiliary headlights<sup>OE</sup>

- Make sure the ground is level and firm and place the motorcycle on its centre stand.

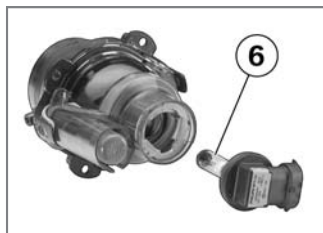

- Insert bulb **6** into its socket and turn it clockwise to install.

- Remove the front seat (➔ 61)
- Removing right side panel (➔ 129)

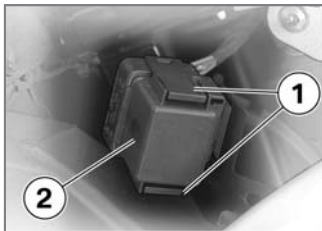

- Squeeze locking clips **1** at top and bottom together and pull fuse cover **2** aside to remove.
- Replace the defective fuse.



Auxiliary headlight fuses

with OE Supplementary headlight:

– 7.5 A<

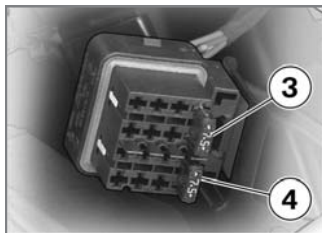

- Replace fuse **3** for left headlight.
- Replace fuse **4** for right headlight.
- Install the fuse cover.
- Installing right side panel (➔ 129)
- Install the front seat (➔ 62)

## Air filter

### Removing air filter

- Make sure the ground is level and firm and place the motorcycle on its centre stand.

- Remove the front seat (➔ 61)
- Removing right side panel (➔ 129)

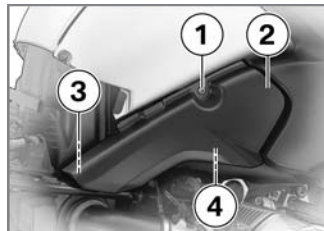

- Remove screw **1**.
- Pull side cover **2** out of holders **3** and **4**.

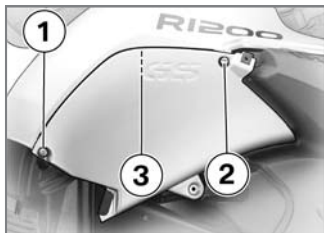

- Remove screws **1** and **2**.
- Pull the knee cover out of holder **3**.

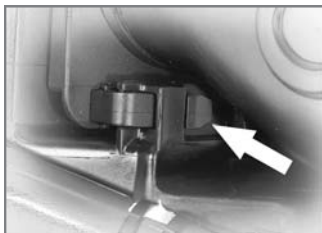

- To do so, press the rear of the clip and pull out the clip.



- Pull out air filter **3** at the bottom.

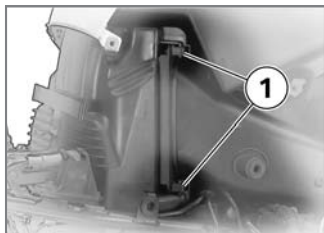

- Disengage retaining clip **1**.

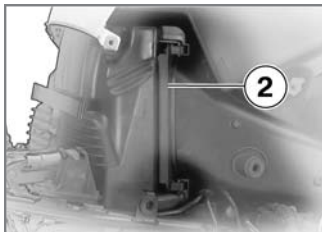

- Pull the intake air pipe out of holder **2**.

### Installing air filter



- Insert air filter **3** into the air filter housing at the top.

- Push the air filter into the air filter housing at the bottom, making sure that the vanes are not bent.

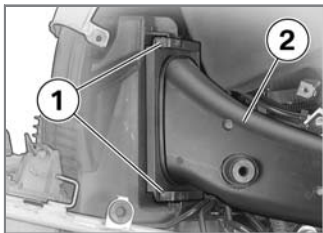

- Position intake air pipe **2** on the air filter housing.
- Push retaining clips **1** into the holders until they engage with an audible click.

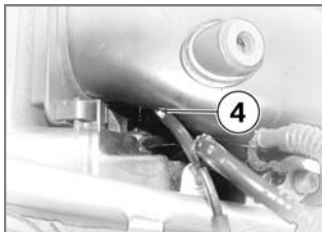

- Check that the throttle-valve cable is seated in guide **4** of the intake and that the throttle valve is seated against the stop.

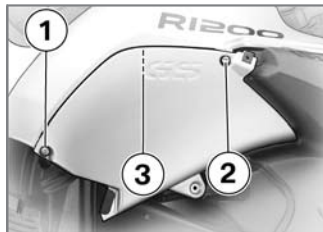

- Seat the knee cover in holder **3**.
- Install screws **2** and **1**.

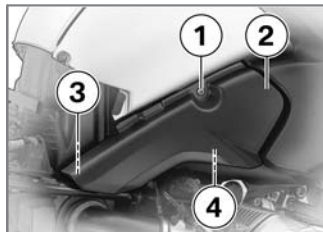

- Seat side panel **2** in holders **3** and **4**.
- Install screw **1**.

- Installing right side panel (➔ 129)
- Install the front seat (➔ 62)

## Removing right side panel

- Make sure the ground is level and firm and place the motorcycle on its centre stand.
- Remove the front seat (➔ 61)

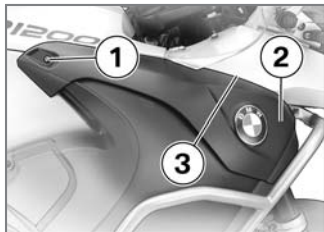

- Remove screw **1**.
- Remove screw **2** on the in-board side.

- Pull the side panel out of holder **3**.

## Installing right side panel



- Apply rubber care product to holder **3** and seat the side panel in the holder.



- Install screw **2** on the in-board side.
- Install screw **1**.
- Install the front seat (➔ 62)

## Jump start

 The wires leading to the power socket do not have a load-capacity rating adequate for jump-starting the engine. Excessively high current can lead to a cable fire or damage to the vehicle electronics.

Do not use the on-board

socket to jump-start the engine of the motorcycle. ◀

**!** Touching live parts of the ignition system with the engine running can cause electric shock.

Do not touch parts of the ignition system when the engine is running. ◀

**!** A short-circuit can result if the crocodile clips of the jump leads are accidentally brought into contact with the motorcycle.

Use only jump leads fitted with fully insulated crocodile clips at both ends. ◀

**!** Jump-starting with a donor-battery voltage higher than 12 V can damage the vehicle electronics.

Make sure that the battery of the donor vehicle has a voltage rating of 12 V. ◀

**!** If it is not standing firmly, the motorcycle could topple in the course of the operations described below. Always make sure that the motorcycle is stable and firmly supported. ◀

- Make sure the ground is level and firm and place the motorcycle on its stand.
- Remove the front seat (➔ 61)

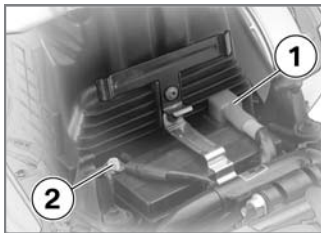

- When jump-starting the engine, do not disconnect the

battery from the on-board electrical system.

- Remove protective cap **1** from the battery's positive terminal.
- Begin by connecting one end of the red jump lead to the positive terminal of the discharged battery and the other end to the positive terminal of the donor battery.
- Then connect one end of the black jump lead to negative terminal **2** of the donor battery, and the other end to the negative terminal of the discharged battery.

**▷** The spring-strut screw can be used as an alternative to the battery's negative terminal. ◀

- Run the engine of the donor vehicle during jump-starting.

- Start the engine of the vehicle with the discharged battery in the usual way; if the engine does not start, wait a few minutes before repeating the attempt in order to protect the starter motor and the donor battery.
- Allow both engines to idle for a few minutes before disconnecting the jump leads.
- Disconnect the jump lead from the negative terminals first, then disconnect the second lead from the positive terminals.
- Remember to reinstall the protective cap on the battery's positive terminal.

 Do not use proprietary start-assist sprays or other products to start the engine. ◀

- Install the front seat (⇒ 62)

## Battery

### Maintenance instructions

Correct upkeep, recharging and storage will prolong the life of the battery and are essential if warranty claims are to be considered.

Compliance with the points below is important in order to maximise battery life:

- Keep the surface of the battery clean and dry
- Do not open the battery
- Do not top up with water
- Be sure to read and comply with the instructions for charging the battery on the following pages
- Do not turn the battery upside down



If the battery is not disconnected, the on-board electronics (e.g. clock, etc.) gradually drain the battery. This can cause the battery to run flat. If this happens, warranty claims will not be accepted.

If the motorcycle is to be out of use for more than four weeks, disconnect the battery or connect a suitable trickle charger to the battery. ◀



BMW Motorrad has developed a trickle-charger specially designed for compatibility with the electronics of your motorcycle. Using this charger, you can keep the battery charged during long periods of disuse, without having to disconnect the battery from the motorcycle's on-board systems. You can obtain additional information

from your authorised BMW Motorrad dealer. ◀

## Charging battery when connected

 Charging the connected battery directly at the battery terminals can damage the vehicle electronics.

Always disconnect the battery from the on-board circuits before recharging it with a charger connected directly to the battery posts. ◀

 If you switch on the ignition and the multifunction display and telltale lights fail to light up, the battery is completely flat. Attempting to charge a completely flat battery via the on-board socket can cause damage to the motorcycle's electronics. If a battery has discharged to the extent that it is completely

flat, it has to be disconnected from the on-board circuits and charged with the charger connected directly to the battery posts. ◀

 Only chargers suitable for this mode of charging can be used to recharge the battery via the on-board socket. Unsuitable chargers could cause damage to the motorcycle's on-board electrics. Use BMW chargers with the part numbers 71 60 7 688 864 (220 V) or, as applicable, 71 60 7 688 865 (110 V). If you are in doubt, disconnect the battery from the on-board systems and connect the charger directly to the battery. ◀

- Charge via the power socket, with the battery connected to the motorcycle's on-board electrical system.

 The motorcycle's on-board electronics know when the battery is fully charged. The on-board socket is switched off when this happens. ◀

- Comply with the operating instructions of the charger.

 If you are unable to charge the battery through the on-board socket, you may be using a charger that is not compatible with your motorcycle's electronics. If this happens, disconnect the battery from the on-board systems and connect the charger directly to the battery. ◀

## Charging battery when disconnected

- Charge the battery using a suitable charger.

- Comply with the operating instructions of the charger.
- Once the battery is fully charged, disconnect the charger terminal clips from the battery terminals.

▷ The battery has to be recharged at regular intervals in the course of a lengthy period of disuse. See the instructions for caring for your battery. Always fully recharge the battery before restoring it to use◀

## Remove the battery

⚠ If it is not standing firmly, the motorcycle could topple in the course of the operations described below. Always make sure that the motorcycle is stable and firmly supported.◀

- Make sure the ground is level and firm and place the motorcycle on its stand.
- Switch off the ignition.
- Remove the front seat (➔ 61)



- Remove holder **1** for Rider's Manual.

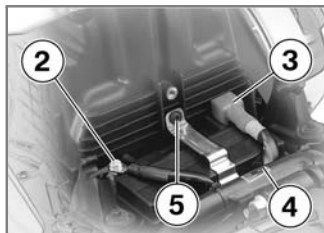

⚠ Disconnection in the wrong sequence increases the risk of short-circuits. Always proceed in the correct sequence.◀

- Disconnect negative battery lead **2** first.
- Open protective cap **3** for the battery's positive terminal.
- Then disconnect positive battery lead **4**.
- Remove screw **5** of the battery retaining strap.

- Disengage the retaining strap at the bottom and remove.
- Lift the battery up and out; work it slightly back and forth if it is difficult to remove.

## Install the battery

**!** If it is not standing firmly, the motorcycle could topple in the course of the operations described below. Always make sure that the motorcycle is stable and firmly supported. ◀

- Make sure the ground is level and firm and place the motorcycle on its stand.
- Switch off the ignition.
- Place the battery in the battery compartment, positive terminal on the right in the forward direction of travel.

- Engage the battery retaining strap at the bottom and push it over the battery.

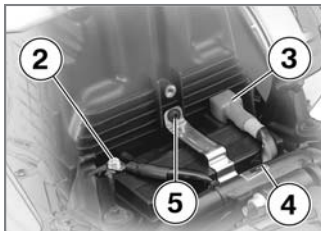

- Install screw **5** of the battery retaining strap.

**!** Installation in the wrong sequence increases the risk of short-circuits. Always proceed in the correct sequence. Never install the battery without the protective cap. ◀

- Connect battery positive lead **4** first.

- Close protective cap **3** for the battery's positive terminal.
- Connect battery negative lead **2**.



- Install holder **1** for Rider's Manual.
- Switch on the ignition.
- Fully open the throttle once or twice.
  - » The engine management system registers the throttle-valve positions.
- Install the front seat (➡ 62)
- Set the clock (➡ 45)

## Care

Care products .....	136
Washing the motorcycle .....	136
Cleaning easily damaged components .....	137
Paint care .....	138
Protective wax coating .....	138
Laying up the motorcycle .....	138
Restoring motorcycle to use .....	139

## Care products

BMW Motorrad recommends that you use the cleaning and care products you can obtain from your authorised BMW Motorrad dealer. The substances in BMW Care Products have been tested in laboratories and in practice; they provide optimised care and protection for the materials used in your vehicle.

 The use of unsuitable cleaning and care products can damage vehicle components.

Do not use solvents such as cellulose thinners, cold cleaners, fuel or the like, and do not use cleaning products that contain alcohol. ◀

## Washing the motorcycle

BMW Motorrad recommends that you use BMW insect remover to soften and wash off insects and stubborn dirt on painted parts prior to washing the motorcycle.

To prevent stains, do not wash the motorcycle immediately after it has been exposed to strong sunlight and do not wash it in the sun. Make sure that the motorcycle is washed frequently, especially during the winter months.

To remove road salt, clean the motorcycle with cold water immediately after every trip.

 After the motorcycle has been washed, ridden through water or ridden in the rain, the brake discs and

pads might be wet and the brakes might not take effect immediately.

Apply the brakes in good time until the brakes have dried out. ◀

 Warm water intensifies the effect of salt.

Use only cold water to wash off road salt. ◀

 The high pressure of steam cleaners can damage seals, the hydraulic brake system, the electrical system, and the seat.

Do not use a steam jet or high-pressure cleaning equipment. ◀

## Cleaning easily damaged components

### Plastics

Clean plastic parts with water and BMW plastic care emulsion. This includes in particular:

- Windscreen and slipstream deflectors
- Headlight lens made of plastic
- Glass cover of the instrument cluster
- Black, unpainted parts

 If plastic parts are cleaned using unsuitable cleaning agents, the surfaces can be damaged.

Do not use cleaning agents that contain alcohol, solvents or abrasives to clean plastic parts.

Even fly-remover pads or cleaning pads with hard

surfaces can produce scratches. ◀

 Soften stubborn dirt and insects by covering the affected areas with a wet cloth. ◀

### Windscreen

Clean off dirt and insects with a soft sponge and plenty of water.

 Fuel and chemical solvents attack the material of the windscreen; the windscreen becomes opaque or dull. Do not use cleaning agents. ◀

### Chrome

Use plenty of water and BMW shampoo to clean chrome, particularly if it has been exposed to road salt. Use chrome polish for additional treatment.

### Aluminium parts

Clean aluminium parts with a suitable cleaning agent; these cleaning agents, too, are available from your authorised BMW Motorrad dealer. Use plenty of water and BMW shampoo to clean aluminium parts exposed to road salt.

### Radiator

Clean the radiator regularly to prevent overheating of the engine due to inadequate cooling.

For example, use a garden hose with low water pressure.

 Cooling fins can be bent easily.

Take care not to bend the fins when cleaning the radiator. ◀

## Rubber

Treat rubber components with water or BMW rubber-care products.



Using silicone sprays for the care of rubber seals can cause damage.

Do not use silicone sprays or other care products that contain silicon. ◀

## Paint care

Washing the motorcycle regularly will help counteract the long-term effects of substances that damage the paint, especially if your motorcycle is ridden in areas with high air pollution or natural sources of dirt, for example tree resin or pollen.

Remove particularly aggressive substances immediately, however, as otherwise the paint can

be affected or become discoloured. Substances of this nature include spilt fuel, oil, grease, brake fluid and bird droppings. We recommend BMW vehicle polish or BMW paint cleaner for this purpose.

Marks on the paintwork are particularly easy to see after the motorcycle has been washed. Remove stains of this kind immediately, using cleaning-grade benzene or petroleum spirit on a clean cloth or ball of cotton wool. BMW Motorrad recommends BMW tar remover for removing specks of tar. Remember to wax the parts treated in this way.

## Protective wax coating

BMW Motorrad recommends applying only BMW car wax or products containing carnauba wax or synthetic wax.

The best way to see whether the paint has to be protected is that water no longer forms pearls.

## Laying up the motorcycle

- Clean the motorcycle.
- Remove the battery.
- Spray the brake and clutch lever pivots and the main and side stand pivots with a suitable lubricant.
- Coat bright metal and chrome-plated parts with an acid-free grease (e.g. Vaseline).
- Stand the motorcycle in a dry room in such a way

that there is no load on either wheel. Authorised BMW Motorrad dealers can provide suitable auxiliary stands.

 Before laying the vehicle up out of use, have the engine oil and the oil filter element changed by a specialist workshop, preferably an authorised BMW Motorrad dealer. Combine work for laying up/restoring to use with a BMW service or inspection.◀

## **Restoring motorcycle to use**

- Remove the protective wax coating.
- Clean the motorcycle.
- Install a charged battery.
- Before starting: work through the checklist.



## Technical data

Troubleshooting chart .....	142
Threaded fasteners .....	143
Engine .....	144
Riding specifications .....	147
Clutch .....	147
Transmission .....	147
Final drive .....	148
Running gear .....	148
Brakes .....	149
Wheels and tyres .....	149
Electrics .....	150
Frame .....	152
Dimensions .....	153
Weights .....	153

## Troubleshooting chart

Engine does not start or is difficult to start

<b>Possible cause</b>	<b>Remedy</b>
Kill switch activated.	Kill switch in operating position (run).
Side stand extended and gear engaged.	Retract the side stand (➡ 72).
Gear engaged and clutch not disengaged.	Select neutral or pull clutch lever (➡ 72).
Clutch pulled when ignition was OFF	Switch on the ignition, then pull the clutch lever.
No fuel in tank.	Refuelling (➡ 78)
Battery not adequately charged.	Charge the battery when connected (➡ 132)

## Threaded fasteners

Front wheel	Value	Valid
<b>Brake caliper to slider tube</b>		
M8 x 32 10.9	30 Nm	
<b>Quick-release axle clamp screws</b>		
M8 x 35	19 Nm	
<b>Quick-release axle in axle holder</b>		
M24 x 1.5	50 Nm	
Rear wheel	Value	Valid
<b>Rear wheel to wheel carrier</b>		
M10 x 53 x 1.25	<b>Tighten in diagonally opposite sequence</b>	
	60 Nm	
Shift lever	Value	Valid
<b>Peg to gearshift lever</b>		
ISA M6 x 16	8 Nm	

Mirrors	Value	Valid
<b>Mirror to clamping piece</b>		
M10	25 Nm	
<b>Clamping piece to clamping block</b>		
M10	30 Nm	

## Engine

Type	
Engine, type	Four-stroke opposed twin, air-cooled with oil-cooled exhaust ports, installed longitudinally, two overhead camshafts, electronic engine management

Technical data	
Effective displacement	1170 cm <sup>3</sup>
Cylinder bore	101 mm
Piston stroke	73 mm
Compression ratio	11.0:1
Nominal output	74 kW, Over: 7000 min <sup>-1</sup>
with OE Power reduction:	72 kW, Over: 7000 min <sup>-1</sup>

Max. torque	115 Nm, Over: 5500 min <sup>-1</sup>
Maximum permissible engine speed	7800 min <sup>-1</sup>
Idle speed	1150±50 min <sup>-1</sup>

### Fuel

Recommended fuel grade	95 ROZ/RON, Super unleaded 91 ROZ/RON, Regular unleaded (fuel grade, usable with power- and consumption-related restrictions)
Usable fuel capacity	33 l
Reserve fuel	4 l

### Engine oil

Engine, oil capacity	4 l, with filter change
Lubricant	Engine oil, 20W-50
Engine oil, quantity for topping up	0.5 l, difference between MIN and MAX

Oil grades	Engine oils of API classification SF or better. Engine oils of ACEA classification A2 or better. BMW Motorrad recommends not using synthetic oils for the first 10,000 km. Please do not hesitate to contact your authorised BMW Motorrad dealer if you have any questions relating the choice of a suitable engine oil for your motorcycle.
<b>Permissible viscosity classes</b>	
SAE 5 W- $\geq 30$	-20...20 °C, Operation at low temperatures
SAE 10 W-40	-10...30 °C, Operation at moderate temperatures
SAE 15 W- $\geq 40$	$\geq 0$ °C
SAE 20 W- $\geq 40$	$\geq 0$ °C
SAE 5 W- $\geq 50$	$\geq -20$ °C, High-grade and synthetic oils, operation in all temperature ranges
SAE 10 W- $\geq 50$	$\geq -20$ °C, High-grade and synthetic oils, operation in all temperature ranges

## Riding specifications

### Speeds

Top speed	>200 km/h
-----------	-----------

### Clutch

Clutch, type	Single dry plate with high-leverage pressure plate
--------------	----------------------------------------------------

### Transmission

Gearbox type	Helical 6-speed gearbox with integral re-action damper, claw-action shift by sliding sleeves
--------------	----------------------------------------------------------------------------------------------

### Gear ratios

Gearbox transmission ratios	1.824 (31:17 teeth), Primary transmission ratio 2.277 (41:18 teeth), 1st gear 1.583 (38:24 teeth), 2nd gear 1.259 (34:27 teeth), 3rd gear 1.033 (31:30 teeth), 4th gear 0.903 (28:31 teeth), 5th gear 0.805 (29:36 teeth), 6th gear
-----------------------------	-------------------------------------------------------------------------------------------------------------------------------------------------------------------------------------------------------------------------------------------------------

## Final drive

Rear wheel drive, type	Shaft drive with bevel gears
Final drive gear ratio	2.82 : 1

## Running gear

Front suspension, type	BMW Telelever, with anti-dive top fork bridge, leading link pivot-mounted on engine and telescopic forks, central spring strut supported by leading link and main frame
Front suspension, total suspension travel	210 mm, At wheel
Rear suspension, type	Central spring strut with single-tube gas-filled shock absorber, adjustable rebound damping and hydraulically adjustable spring preload
Rear suspension, total suspension travel	220 mm, At wheel

## Brakes

### Front brake

Front brakes, type	Hydraulically operated twin disc brake with 4-piston fixed calipers and floating brake discs
Brake-pad material, front	Sintered metal

### Rear brake

Rear brake, type	Hydraulically operated disc brake with 2-piston floating caliper and fixed disc
Friction material, rear brake pads	Organic material

## Wheels and tyres

Front wheel, type	Cross-spoked wheel with 40 spokes, MT H2
Front wheel, rim size	2,50" x 19"
Front wheel, tyre designation	110/80 R 19 M/C 59 V TL
Rear wheel, type	Cross-spoked wheel with 40 spokes, MT H2
Rear wheel, rim size	4,00" x 17"
Rear wheel, tyre designation	150/70 R 17 M/C 69 V TL

<b>Tyre pressures</b>	
Tyre pressure, front	2.2 bar, One-up, tyre cold 2.5 bar, Two-up and/or with luggage, tyre cold
Tyre pressure, rear	2.5 bar, One-up, tyre cold 2.9 bar, Two-up and/or with luggage, tyre cold

## Electrics

On-board socket, rating	5 A
Fuses	The circuits are electronically protected, so plug-in fuses are no longer necessary. If an electronic fuse trips and de-energises a circuit, the circuit is active as soon as the ignition is switched on after the fault has been rectified.
Auxiliary headlight fuses	
with OE Supplementary headlight:	7.5 A

**Battery**

Battery, type	AGM (Absorptive Glass Mat) battery
Battery rated voltage	12 V
Battery rated capacity	14 Ah

**Spark plugs**

Spark plug manufacturer and designation	Bosch YR5LDE
	NGK DCPR 8 EKC
Spark plug electrode gap	0.8±0.1 mm, When new 1 mm, Wear limit
Secondary spark plug manufacturer and designation	Bosch YR5LDE
	NGK DCPR 8 EKC
Secondary spark plug, electrode gap	0.8±0.1 mm, When new 1 mm, Wear limit

**Lighting**

High-beam headlight bulb	H7 / 12 V / 55 W
Low-beam headlight bulb	H7 / 12 V / 55 W
Parking-light bulb	W5W / 12 V / 5 W
Bulb of tail light/brake light	P21/5W / 12 V / 5 W / 21 W
Front flashing turn indicator bulbs	R10W / 12 V / 10 W

with OE White turn indicators:	RY10W / 12 V / 10 W
Rear flashing turn indicator bulbs	R10W / 12 V / 10 W
with OE White turn indicators:	RY10W / 12 V / 10 W
Auxiliary headlight bulbs	
with OE Supplementary headlight:	H11 / PGJ 19-2 / 12 V / 55 W

## Frame

Frame, type	Two-part tubular-steel frame and load-bearing drive unit
Type plate, location	On left side behind side cover
Vehicle identification number (VIN), location	Frame front section, top centre

## Dimensions

Length of motorcycle	2250 mm
Width of motorcycle	955 mm, Across mirrors
with OA Case:	991 mm, Across cases
Height of motorcycle	1470 mm, DIN unladen weight; without mirrors, windscreen lowered
Front-seat height (at unladen weight)	910 mm, High position
	890 mm, Low position

## Weights

Unladen weight	256 kg, DIN unladen weight, ready for road 90 % load of fuel, without optional extras
Permissible gross weight	475 kg
Maximum payload	219 kg, Without optional extras/optional accessories



## Service

BMW Motorrad service .....	156
BMW Motorrad service quality .....	156
BMW Motorrad Service Card: on-the-spot breakdown assistance .....	157
BMW Motorrad service network .....	157
Maintenance work .....	157
Maintenance schedules .....	158
Confirmation of maintenance work .....	159
Confirmation of service .....	164

## BMW Motorrad service

Advanced technology requires specially adapted methods of maintenance and repair.



If maintenance and repair work is performed inexpertly, it could result in consequential damage and thus constitute a safety risk.

BMW Motorrad recommends you to have all the associated work on your motorcycle carried out by a specialist workshop, preferably an authorised BMW Motorrad dealer. ◀

Your authorised BMW Motorrad dealer can provide information on the specified Service, Inspection and Annual Inspection work needed. Have all maintenance and repair work carried out

confirmed in the "Service" chapter in this manual. Authorised BMW Motorrad dealers are supplied with the latest technical information and have the necessary technical know-how. BMW Motorrad recommends that you contact your authorised BMW Motorrad dealer if you have questions regarding your motorcycle.

### BMW Motorrad service quality

Along with its reputation for engineering quality and high reliability, BMW Motorrad is a byword for excellent quality of service.

To ensure that your BMW is always in optimum condition, BMW Motorrad recommends that you have the maintenance work required for your motorcycle carried out reg-

ularly, preferably by your authorised BMW Motorrad dealer. For generous treatment of claims submitted after the warranty period has expired, evidence of regular maintenance is essential.

Certain signs of wear, moreover, may otherwise not be noticed until it is too late to put them right at moderate cost. Your authorised BMW Motorrad dealer's mechanics know every detail of your motorcycle and can take remedial action if necessary before minor faults develop into serious problems. By having the necessary repairs done properly and in good time, you save time and money in the long run.

## **BMW Motorrad Service Card: on-the-spot breakdown assistance**

In the event of a breakdown, the BMW Motorrad Service Card issued with each new BMW motorcycle enables you to access an extensive range of services such as breakdown assistance, motorcycle transportation etc. (details can differ from country to country). In the event of a breakdown, contact BMW Motorrad's Mobile Service. The specialists will provide the necessary advice and assistance.

You will find important country-specific contact addresses and the after-sales service organisation phone numbers in the "Service Kontakt / Service Contact"

brochures, along with information on Mobile Service and the dealership network.

## **BMW Motorrad service network**

BMW Motorrad has an extensive after-sales service network in place to look after you and your motorcycle in more than 100 countries. In Germany alone, you have the best possible access to approximately 200 authorised BMW Motorrad dealers.

All information concerning the international dealership network can be found in the brochures entitled "Service Contact Europe" and "Service Contact Africa, America, Asia, Australia, Oceania".

## **Maintenance work Intervals**

Some maintenance tasks have to be performed after a certain time, others depend on the distance covered by the motorcycle.

### **BMW Running-in Check**

The BMW running-in check has to be performed when the motorcycle has covered between 500 km and 1,200 km

### **BMW Annual Inspection**

Some maintenance work has to be carried out at least once a year. Other tasks depend on the distance the motorcycle has covered.

## **BMW Service**

After the first 10,000 km and every additional 20,000 km (30,000 km, 50,000 km, 70,000 km, etc.) if this distance is covered within a year.

## **BMW Inspection**

After the first 20,000 km and every additional 20,000 km (40,000 km, 60,000 km, 80,000 km, etc.) if this distance is covered within a year.

## **Maintenance schedules**

The maintenance schedule for your motorcycle depends on the equipment fitted, and on the motorcycle's age and the distance it has covered. Your authorised BMW Motorrad dealer will be happy to supply

a copy of the current maintenance schedule for your motorcycle on request.

## Confirmation of maintenance work

### **BMW Pre-delivery Check**

Carried out in accordance with manufacturer's instructions

\_\_\_\_\_  
Date, stamp, signature

### **BMW Running-in Check**

Carried out in accordance with manufacturer's instructions

Odometer reading \_\_\_\_\_

Brake fluid, new

\_\_\_\_\_  
Date, stamp, signature

**BMW Service**

- BMW Annual Inspection
- BMW Service
- BMW Inspection

Carried out in accordance with manufacturer's instructions

Odometer reading\_\_\_\_\_

- Brake fluid, new

\_\_\_\_\_  
Date, stamp, signature

**BMW Service**

- BMW Annual Inspection
- BMW Service
- BMW Inspection

Carried out in accordance with manufacturer's instructions

Odometer reading\_\_\_\_\_

- Brake fluid, new

\_\_\_\_\_  
Date, stamp, signature

**BMW Service**

- BMW Annual Inspection
- BMW Service
- BMW Inspection

Carried out in accordance with manufacturer's instructions

Odometer reading\_\_\_\_\_

- Brake fluid, new

\_\_\_\_\_  
Date, stamp, signature

### **BMW Service**

- BMW Annual Inspection
- BMW Service
- BMW Inspection

Carried out in accordance with manufacturer's instructions

Odometer reading\_\_\_\_\_

- Brake fluid, new

\_\_\_\_\_  
Date, stamp, signature

### **BMW Service**

- BMW Annual Inspection
- BMW Service
- BMW Inspection

Carried out in accordance with manufacturer's instructions

Odometer reading\_\_\_\_\_

- Brake fluid, new

\_\_\_\_\_  
Date, stamp, signature

### **BMW Service**

- BMW Annual Inspection
- BMW Service
- BMW Inspection

Carried out in accordance with manufacturer's instructions

Odometer reading\_\_\_\_\_

- Brake fluid, new

\_\_\_\_\_  
Date, stamp, signature

**BMW Service**

- BMW Annual Inspection
- BMW Service
- BMW Inspection

Carried out in accordance with manufacturer's instructions

Odometer reading\_\_\_\_\_

- Brake fluid, new

\_\_\_\_\_  
Date, stamp, signature

**BMW Service**

- BMW Annual Inspection
- BMW Service
- BMW Inspection

Carried out in accordance with manufacturer's instructions

Odometer reading\_\_\_\_\_

- Brake fluid, new

\_\_\_\_\_  
Date, stamp, signature

**BMW Service**

- BMW Annual Inspection
- BMW Service
- BMW Inspection

Carried out in accordance with manufacturer's instructions

Odometer reading\_\_\_\_\_

- Brake fluid, new

\_\_\_\_\_  
Date, stamp, signature

### **BMW Service**

- BMW Annual Inspection
- BMW Service
- BMW Inspection

Carried out in accordance with manufacturer's instructions

Odometer reading\_\_\_\_\_

- Brake fluid, new

\_\_\_\_\_  
Date, stamp, signature

### **BMW Service**

- BMW Annual Inspection
- BMW Service
- BMW Inspection

Carried out in accordance with manufacturer's instructions

Odometer reading\_\_\_\_\_

- Brake fluid, new

\_\_\_\_\_  
Date, stamp, signature

### **BMW Service**

- BMW Annual Inspection
- BMW Service
- BMW Inspection

Carried out in accordance with manufacturer's instructions

Odometer reading\_\_\_\_\_

- Brake fluid, new

\_\_\_\_\_  
Date, stamp, signature



Item	Odometer reading	Date

**A**

- Abbreviations and symbols, 6
- ABS, 15
- Accessories
  - General instructions, 90
- Air filter
  - Installation, 127
  - Removal, 126

**B**

- Battery
  - Charging battery when connected, 132
  - Charging battery when disconnected, 132
  - Installation, 14, 134
  - Maintenance instructions, 131
  - Removal, 14, 133
  - Technical data, 151
  - Warning, battery charge current, 26

- Brake fluid
  - Checking fluid level, front brakes, 106
  - Checking fluid level, rear brakes, 107
  - Fluid level, front, 13
  - Fluid level, rear, 13
- Brake lever
  - Adjusting footbrake lever, 56
  - Adjusting handbrake lever, 55
  - Footbrake lever, 55
- Brake pads
  - Checking front, 104
  - Checking rear, 105
  - Running in, 76
- Brakes
  - Checking operation, 104
  - Technical data, 149
- Breakdown assistance kit
  - Holdings, 14
- Bulbs
  - general instructions, 117
  - Replacing auxiliary headlight, 124

- Replacing brake light and rear light bulb, 121
- Replacing fuses for auxiliary headlights, 125
- Replacing high-beam headlight bulb, 118
- Replacing low-beam headlight bulb, 118
- Replacing parking-light bulb, 120
- Replacing turn indicator bulbs, 122
- Technical data, 151
- Warning, bulb failure, 26, 27

**C**

- Case
  - Closing, 93
  - Installing, 94
  - Installing lid, 93
  - Opening, 92
  - Removing, 94
  - Removing lid, 93
- Checklist, 72

Clock, 20  
  Adjusting, 17, 45

Clutch  
  Adjusting clutch lever, 54  
  Fluid level, 11  
  Technical data, 147

Confirmation of maintenance work, 159

Currency, 7

**E**

Electrics  
  Technical data, 150

Emergency off switch (kill switch), 16

Engine  
  Starting, 72  
  Technical data, 144  
  Temperature gauge, 20  
  Warning, engine electronics, 24

Engine oil  
  Checking fluid level, 11, 102  
  Technical data, 145  
  Temperature gauge, 21

Topping up, 11, 103  
  Warning, engine oil level, 25  
  Warning, engine oil pressure, 25

Equipment, 7

EWS  
  Warning, 24

**F**

Final drive  
  Technical data, 148

Footbrake lever, 13

Frame  
  Technical data, 152

Front seat  
  Adjusting, 62  
  Installation, 62  
  Removal, 61

Front-wheel stand, 116

Fuel  
  Quantity reading, 20  
  Refuelling, 78  
  Warning, fuel down to reserve, 24

Fuel tank, 13

Fuses, 150  
  Replacing for auxiliary headlights, 125

**G**

Gear indicator, 20  
Grip heating, 16

**H**

Handlebar fittings  
  General view, left side, 15  
  General view, right side, 16

Hazard warning flashers, 15, 16  
  Switching off, 43  
  Switching on, 42

Headlight  
  Adjusting, 11  
  Adjusting headlight beam throw, 59  
  Adjustment for driving on left/driving on right, 59

Headlight flasher, 15

Helmet holder, 14

High-beam headlight, 15

Horn, 15

**I**

- Ignition
  - Switching off, 40
  - Switching on, 40
- Immobiliser
  - Warning, 24
- Instrument cluster
  - Overview, 17
  - Sensor for lighting, 17

**J**

- Jump start, 129

**K**

- Keys, 40, 42

**L**

- Laying up, 138

**Lights**

- Switching off parking lights, 58
- Switching on high-beam headlight, 57
- Switching on low-beam headlight, 57
- Switching on parking lights, 57
- Switching on side lights, 57

**M**

- Maintenance
  - General instructions, 100
  - Intervals, 157
- Multifunction display, 20
  - Anti-theft alarm, 17

**O**

- Odometer and tripmeters, 20
  - Resetting tripmeter, 44
  - Selecting readings, 43
- On-board computer
  - Ambient temperature, 47
  - Average consumption, 48

- Average speed, 47
- Oil level, 49
- Range, 49
- Resetting average consumption, 48
- Resetting average speed, 48
- Selecting readings, 46

**P**

- Power socket, 11
- Pre-ride check, 73

**R**

- Refuelling, 78
- Reserve
  - Warning, 24
- Residual range, 44
- Restoring to use, 139
- Rev. counter, 17
- Rider's Manual, 14
- Running gear
  - Technical data, 148

## S

- Safety instructions
  - Correct loading, 70
- Seat
  - Lock, 11
  - Overview, 14
- Service, 156
- Service Card, 157
- Shift lever
  - Adjusting, 56
- Side stand
  - starting the engine, 72
- Spark plugs
  - Technical data, 151
- Speedometer, 17
- Spring preload
  - Adjusting, 64, 65
- Spring preload, front
  - Adjusting, 65
- Spring preload, rear
  - Adjusting, 13, 64
- Starter, 16
- Steering lock
  - Locking, 41

- Supplementary headlight
  - Switching off, 58
  - Switching on, 58
- Suspension damping, rear
  - Adjusting, 11, 66

## T

- Technical data
  - Battery, 151
  - Brakes, 149
  - Bulbs, 151
  - Clutch, 147
  - Electrics, 150
  - Engine, 144
  - Engine oil, 145
  - Final drive, 148
  - Frame, 152
  - Running gear, 148
  - Spark plugs, 151
  - Standards, 7
  - Transmission, 147
  - Tyre pressures, 4, 150
  - Wheels and tyres, 149
- Telltale lights, 17
- Toolkit, 14
- Service kit, 101
- Standard equipment, 100
- Topcase, 95
  - Closing, 95
  - Installing, 97
  - Possible adjustments, 98
  - Removing, 96
  - Repositioning, 98
- Torques, 143
- Transmission
  - Starting engine, 72
  - Technical data, 147
- Troubleshooting chart, 142
- Turn indicators
  - Left, 15
  - Right, 16
  - Switching off, 16, 61
  - Switching on left, 60
  - Switching on right, 60
- Tyre pressure control (ReifenDruck-Control)
  - Label on wheel rim, 110
  - Operation, 44

**Tyres**

- Approved tyres, 110
- Checking tread depth, 109
- Checking tyre pressures, 67
- Inflation pressures, 4, 150
- Running in, 76
- Technical data, 149
- Top speed, 109

**V****Vehicle**

- General view, left side, 11
- General view, right side, 13
- Laying up, 138
- Restoring to use, 139

**W**

- Warning lights, 17
- Warnings, 20
  - Mode of presentation, 21
- Warnings, overview, 22, 30, 34, 36

**Wheels**

- Installing front wheel, 113
- Installing rear wheel, 115
- Removing front wheel, 111
- Removing rear wheel, 115
- Technical data, 149

**Windscreen**

- Adjusting, 11

Details described or illustrated in this booklet may differ from the motorcycle's actual specification as purchased, the accessories fitted or the national-market specification. No claims will be entertained as a result of such discrepancies.

Dimensions, weights, fuel consumption and performance data are quoted to the customary tolerances.

The right to modify designs, equipment and accessories is reserved.

Errors and omissions excepted.

© 2006 BMW Motorrad

Not to be reproduced either wholly or in part without written permission from BMW

Motorrad, After Sales.

Printed in Germany.

## Important data for refuelling

---

### Fuel

---

Recommended fuel grade	95 ROZ/RON, Super unleaded 91 ROZ/RON, Regular unleaded (fuel grade, usable with power- and consumption-related restrictions)
------------------------	----------------------------------------------------------------------------------------------------------------------------------------------

---

Usable fuel capacity	33 l
----------------------	------

---

Reserve fuel	4 l
--------------	-----

---

### Tyre pressures

---

Tyre pressure, front	2.2 bar, One-up, tyre cold 2.5 bar, Two-up and/or with luggage, tyre cold
----------------------	---------------------------------------------------------------------------------

---

Tyre pressure, rear	2.5 bar, One-up, tyre cold 2.9 bar, Two-up and/or with luggage, tyre cold
---------------------	---------------------------------------------------------------------------------

---

BMW recommends 

Order No. 01 41 7 706 231  
06.2006, 2nd edition



## Applies to: Motorcycles with hand protectors<sup>OA</sup>

### Possibility of malfunction due to incorrectly positioned hand protector

If the hand protector is twisted out of position relative to the handlebar lever to the extent that the two come into contact, there is a possibility of the handlebar lever remaining continuously in the partly operated position. This in turn can cause problems with the clutch or brake function, depending on which lever is affected.

Possible causes can be:

- Crash or fall
- Lack of due care when transporting the motorcycle
- Threaded fasteners working loose

- Impermissible ergonomic settings (see Rider's Manual, "Adjusting clutch lever/ handlebar lever" or, as applicable, "Adjusting brake lever/handlebar lever").
- Before riding off, always check that there is nothing to impede the movement of the clutch lever and the handbrake lever.

### Checking freedom of movement of handlebar levers



The movement of the handlebar levers is not impeded if

- you can insert a finger into the gap between the handlebar lever and the hand protector,

or

- the handlebar lever is easily pushed forward from its normal released position.

## Aligning hand protector



Note on safety

- Push the handlebar lever fully forward. Turn the hand protector until the tip of the handlebar lever touches the cross on the label.
- Have the settings and the threaded-fastener tightening torques checked by a specialist workshop, preferably an authorised BMW Motorrad dealer.