

Rider's Manual (US Model)

R 1200 GS



BMW Motorrad



Welcome to BMW

We congratulate you on your choice of a motorcycle from BMW and welcome you to the community of BMW riders.

Familiarize yourself with your new motorcycle, so that you can ride it safely and confidently in all traffic situations.

To make sure of this, please read this Rider's Manual carefully before starting to use your new motorcycle. It contains important information on how to operate the controls and how to make the best possible use of all your BMW's technical features.

In addition, it contains information on maintenance and care to help you maintain your motorcycle's reliability and safety, as well as its value. It also offers useful hints and information on the correct equipment for machine and rider, again geared toward maximizing reliability and safety.

If you have any questions concerning your motorcycle, your authorized BMW Motorrad retailer will gladly provide advice and assistance.

We hope you enjoy reading this Rider's Manual and wish you many a pleasant, safe journey on your BMW motorcycle.

Best wishes,

BMW Motorrad

About this Rider's Manual

We have tried to make all the information in this Rider's Manual easy to find.

The quickest access to a particular topic or item is by consulting the detailed alphabetical index at the end. The first chapter of this Rider's Manual will provide you with an initial overview of your motorcycle.

When the time comes to sell your BMW, please remember to hand over this Rider's Manual; it is, by law, an important part of the vehicle.

Symbols and abbreviations

WARNING

This symbol indicates precautions and measures which are essential in protecting the rider and other persons from severe or fatal injury.

CAUTION

Instructions and precautions specifically intended to prevent damage to the motorcycle. Disregarding them may render the warranty invalid.

NOTE

Special information on operating and inspecting your motorcycle as well as maintenance and adjustment procedures.



Tightening torque:

This symbol introduces values for the various tightening torques

- This symbol introduces a passage containing instructions on how to perform a particular operation
- This symbol draws your attention to the outcome of the instructions on how to perform a particular operation

() Figure in parentheses
▣▶ page number with explanations

OE Optional equipment
Your motorcycle was assembled complete with all the optional equipment you ordered

OA Optional accessory
You can obtain optional accessories only through your authorized BMW Motorrad retailer or specialized retail outlet; optional accessories must be retrofitted to the motorcycle

EWS Electronic immobilizer
DWA Anti-theft alarm

Custom equipment

When you ordered your BMW motorcycle, you chose various items of custom equipment.

This Rider's Manual describes all the optional equipment (OE) and selected optional accessories (OA) that BMW offers for this model series.

This explains why the manual may also contain descriptions of equipment which you have not ordered.

If your BMW was supplied with equipment not described in this Rider's Manual (such as a radio or anti-theft alarm, for example), you will find these features described in separate manuals.

Technical specifications

All dimensions, weights and power ratings stated in the Rider's Manual are quoted to the standards and comply with the tolerance requirements of the Deutsche Institut für Normung e. V. (DIN). Configurations for individual countries may differ.

Currency

The high safety and quality standards of BMW motorcycles are maintained by unceasing development work on designs, equipment and accessories.

Because of this, your motorcycle may differ from the information supplied in the Rider's Manual. Nor can errors and omissions be entirely ruled out. We hope you will appreciate that no legal claims can be entertained on the basis of the data, illustrations or descriptions in this manual.

For your own safety



Use only parts and accessories approved by BMW for your motorcycle.

Parts and products approved for your motorcycle by BMW have been checked for safety, function and suitability. BMW accepts product liability for these products. Conversely, BMW is unable to accept any liability whatsoever for parts and accessories which it has not approved.

BMW cannot assess every product of outside origin in order to decide whether it can be used on or with a BMW vehicle without constituting a safety hazard.

Even approval by an official inspection authority such as the TÜV in Germany, or an official permit (General Operating Permit) cannot always provide this guarantee.

Genuine BMW parts and accessories and other products which BMW has approved can be obtained from your authorized BMW Motorrad retailer, together with expert advice on their installation and use.

The right clothing

To reach your destination safely every time, there's only one choice:

- Helmet
- Suit
- Gloves
- Boots

It's foolish to ride without the right clothing. This applies even to short journeys, and to every season of the year.

Your authorized BMW Motorrad retailer will be happy to provide advice and tell you about the latest developments, and help you select the right clothing for your purpose.

Service

For safety reasons and to maintain the value of your motorcycle, regular maintenance intervals have been laid down. Always keep to the specified maintenance intervals. This is the only way to ensure that warranty claims are not invalidated. Your authorized BMW Motorrad retailer can provide information on the currently specified Service, Inspection and Annual Inspection needed, or you can fetch the information from the Internet whenever you want by visiting ["www.bmw-motorrad.com/maintenance"](http://www.bmw-motorrad.com/maintenance).

Important:

BMW refuses to accept liability for damage or consequential damage due to repairs or service work performed by other than BMW-authorized workshops.

Consequently, we advise you to have service and inspection work performed by your authorized BMW Motorrad retailer's specially trained, expert personnel, and confirmed by an entry in the "Service" section of this Rider's Manual.

Authorized BMW Motorrad retailers are supplied with the latest technical information and have the necessary technical know-how and specially trained staff.

Please do not hesitate to contact your authorized BMW Motorrad retailer on all matters concerning your motorcycle. Authorized BMW Motorrad retailers are fully informed about all aspects of your motorcycle and will gladly advise and assist you.

Best wishes,

BMW Motorrad

Contents

Welcome to BMW	1	Shock-absorber adjustment	52
General information	2-4	Wheels	53
Safety information	5-7	Loading	54-55
Overview	11	Shift lever	56
General view, left side	12	Riding	57
General view, right side	13	Safety instructions	58-59
Left handlebar fitting	14	Checklist	60-61
Right handlebar fitting	15	First time out	62-63
Cockpit	16	Before you start	64-66
Status indicators	17	Starting	67
Indicator and warning lights	18	Running in	68-69
Multifunction display	19	Gear shifts	70-71
Function indicators	20	Off-road riding	72-73
Warning indicators	21-23	Parking	74-77
ABS warning lights	24-25	Refueling	78-79
Operation	27	Brake system - general	80-81
Ignition switch and steering lock	28-29	Brake system - with BMW Integral ABS	82-89
Electronic immobilizer EWS	30-31	Accessories	91
Hazard warning flashers	32-33	General instructions	92
Tripmaster	34-35	12 V sockets	93-94
Kill switch	36	Luggage system	95-101
Heated handlebar grips	37	Arrive safely	103
Clock	38	Reliable operation	104
Windshield	39	Service worldwide	105
Handlebar levers	40-41	Training means extra safety	106
Lights	42-45		
Seat	46-48		
Mirrors	49		
Spring preload	50-51		

Maintenance	107	Technical data	159
Safety information.....	108	Engine.....	160
Troubleshooting chart.....	109-110	Power train.....	161
Engine oil	111-112	Frame and suspension.....	162-166
Brake system - general	113-114	Fuel and lubricants.....	167-168
Brake system	115-116	Electrical system	169
Clutch	117	Dimensions and weights	170
Wheels	118-129	Performance data.....	171
Brake pads.....	130-131	Tightening torques	172
Notes on changing bulbs.....	132	Service	173
Bulbs.....	133-139	Maintenance	174
Air filter	140-142	Confirmation of maintenance	174-180
Jump starting	143-145	Confirmation of service	181-182
Battery maintenance instructions.....	146-148	Concluding thoughts.....	183
Installing battery	149-150	Index	185-192
Care	151		
Cleaning/care.....	152-155		
Storing	156		
Returning to use.....	157		

Contents

i
10

Introduction

General view, left side

General view, right side

Left handlebar fitting

Right handlebar fitting

Cockpit

General view, left side

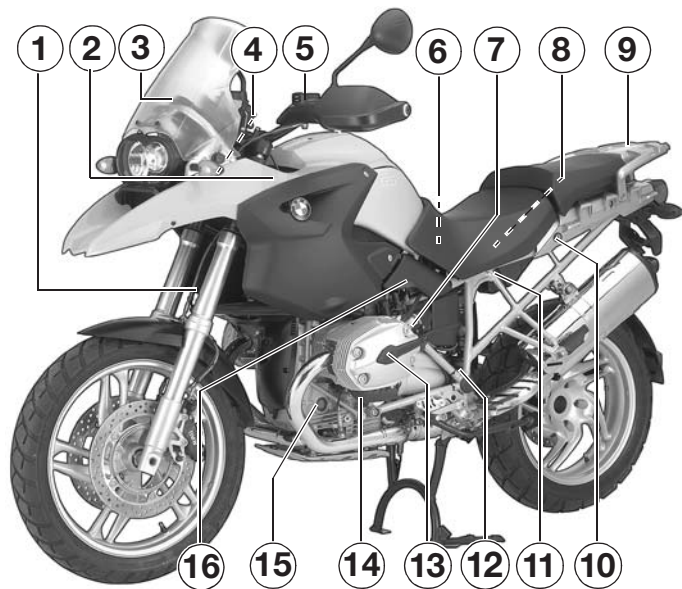

- | | |
|-------------------------------------------------------|------------------------------------------------------------------------------|
| 1 Spring-strut adjuster, front (➡ 50) | 10 Seat lock (➡ 46-48) |
| 2 Power socket 12 V ^{OA} (➡ 93) | 11 On-board socket, 12 V for connecting electrical accessories (➡ 93) |
| 3 Windshield, (➡ 39) | 12 Rear suspension strut, shock-absorber adjuster (➡ 51-52) |
| 4 Headlight adjustment (➡ 45) | 13 Primary spark plug |
| 5 Reservoir for clutch hydraulic fluid (➡ 117) | 14 Secondary spark plug |
| 6 Helmet holder | 15 Engine oil level display (➡ 112) |
| 7 Engine oil filler neck (➡ 111-112) | 16 Type plate |
| 8 Seat adjustment (➡ 47) | |
| 9 Luggage rack (➡ 101) | |

General view, right side

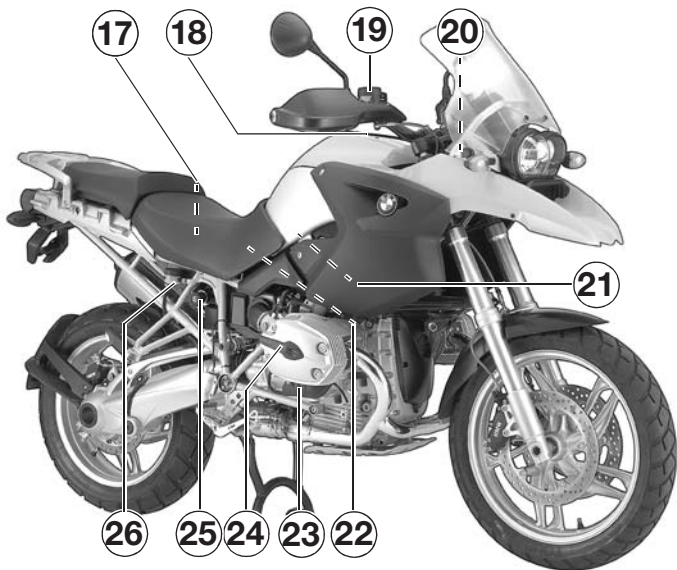

- 17** Toolkit storage compartment
- 18** Fuel filler cap (➔ 78-79)
- 19** Brake-fluid reservoir for front brake (➔ 115)
- 20** Vehicle identification number
- 21** Air filter (➔ 140-142)
- 22** Helmet holder
- 23** Secondary spark plug
- 24** Primary spark plug
- 25** Spring-strut adjuster, rear (➔ 51)
- 26** Brake-fluid reservoir for rear brake (➔ 116)

Left handlebar fitting

1

14

Overview

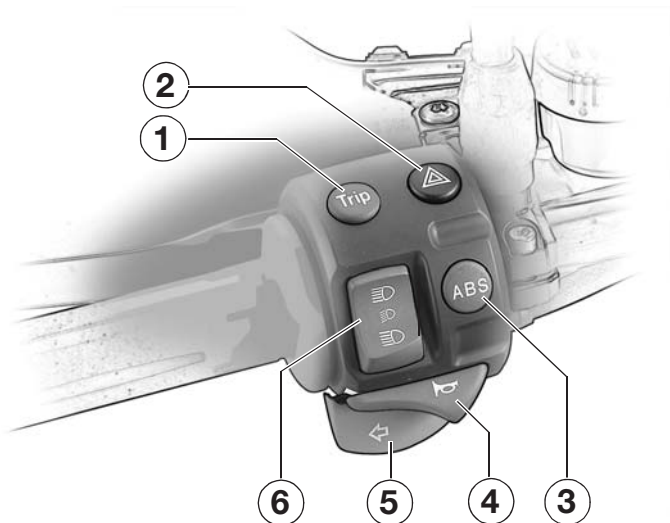

⚠️ WARNING

To prevent air from entering the hydraulic circuit:

- **Do not turn the fitting on the handlebar.**
- **Do not turn the handlebars in the clamping blocks.**

- 1 Tripmaster button (➡ 34)
- 2 Hazard warning flasher switch (➡ 32)
- 3 ABS button^{OE} (➡ 88)
- 4 Horn switch
- 5 Left flashing turn indicator switch
- 6 High/low beam switch (➡ 42-45)

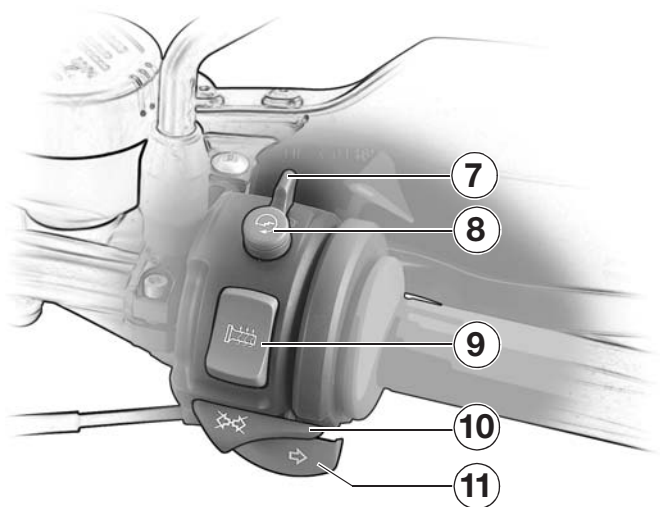

⚠ WARNING

To prevent air from entering the brake circuit:

- Do not turn the fitting on the handlebar.
- Do not turn the handlebars in the clamping blocks.

- 7** Emergency off (kill) switch for ignition (➔ 65)
- 8** Starter button (➔ 67)
- 9** Switch for heated handlebar grips^{OE} (➔ 37)
- 10** Turn indicator cancel switch
- 11** Right flashing turn indicator switch

Cockpit

1

16

Overview

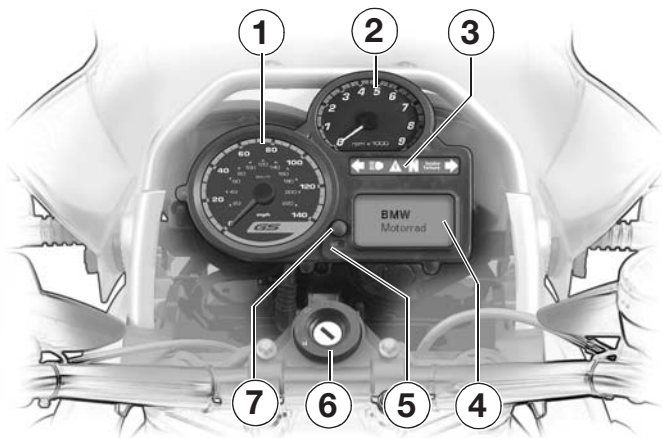

- 1 Speedometer
- 2 Tachometer (►► 68)
- 3 Indicator and warning lights (►► 18)
- 4 Multifunction display (►► 19)
- 5 Indicator light for anti-theft alarm^{OE} /Lighting sensor bright/dark
- 6 Ignition switch and steering lock (►► 28)
- 7 Knob for setting clock (►► 38)

NOTE

The cockpit lights have automatic brightness control for daytime/night-time riding. The sensor that controls the brightness of the cockpit lights is next to the indicator light for the anti-theft alarm^{OE}.

Indicator and warning lights

Multifunction display

Function indicators

Warning indicators

ABS^{OE} warning lights

Indicator and warning lights

2

18

Status indicators

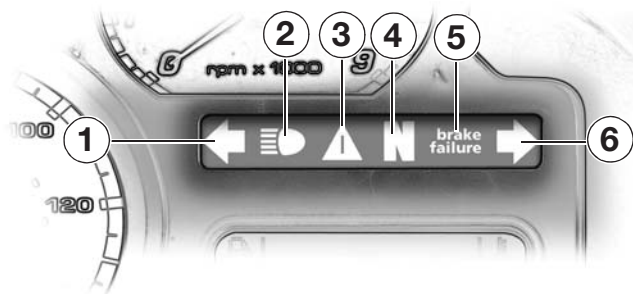

1 Left turn indicator light 

2 High beam indicator light 

3 General warning light 
(→ 86)



4 Neutral indicator light 
(→ 66)

5 ABS warning light  OE
(→ 86)



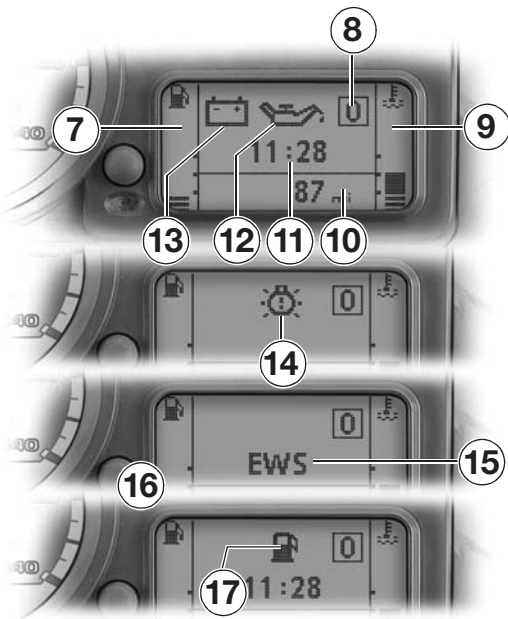

6 Right turn indicator light 

Multifunction display



- 7 Fuel level 
(➔ 20, 79)
- 8 Gear indicator (➔ 66)
- 9 Oil temperature  (➔ 20)
- 10 Tripmaster display panel
(➔ 34, 35)
- 11 Clock display panel (➔ 38)

Possible warnings

- 12 Oil pressure  (➔ 21)
- 13 Battery charge light 
(➔ 22)
- 14 Bulb failure 
- 15 **EWS** active (➔ 30)
- 16 Fault in electronic engine management system 
(➔ 21)
- 17 Fuel reserve indicator 
(➔ 20, 79)







Function indicators

2

20

Status indicators



Indicator light	Multifunction display	Meaning
	11 : 28	Clock Shows the time in 12-hour mode
N		Gear indicator Indicator light N lights up when the transmission is in neutral. The display shows a number corresponding to the gear you have engaged
 yellow flashes		Fuel level when the reserve range is reached, the symbol  appears and flashes, the general warning symbol  flashes. The Tripmaster calculates the residual operating range and shows this estimated figure on the display.
 red ON		Engine temperature The bar indicator flashes if the engine overheats and general warning light  lights up.





Warning indicators



2

21

Status indicators

Warning light	Multifunction display	Meaning/measure
 yellow ON		<p>Engine electronics</p> <p>There is a fault in the electronic engine management system.</p> <p>Maintain a defensive riding style and proceed immediately to a specialized workshop, preferably an authorized BMW Motorrad retailer.</p>
 red ON		<p>Oil pressure</p> <p>Insufficient engine oil pressure ( 111, 112)</p> <p>Taking the traffic situation into account: Disengage the clutch Operate the emergency (kill) switch Bring the motorcycle safely to a halt Check the engine oil level</p> <p>CAUTION</p> <p>If the warning indicator lights up but the oil level is correct, always consult a specialized workshop without delay, preferably an authorized BMW Motorrad retailer.</p>













Warning indicators

2

22

Status indicators



Warning light	Multifunction display	Meaning/measure
 red ON		Battery charge current The battery is no longer charging, generator fault. Immediately consult a specialized workshop, preferably an authorized BMW Motorrad retailer.
 yellow ON		Bulb failure  Rear light or brake light defective Replace bulbs (➡ 133)
	 	Bulb failure  Front parking light, low-beam headlight, high-beam headlight defective  Double flashing frequency, turn indicator flasher defective Replace bulbs (➡ 134-139)
 yellow ON		 Combination of light defects described above Replace bulbs (➡ 134-139)

Warning indicators

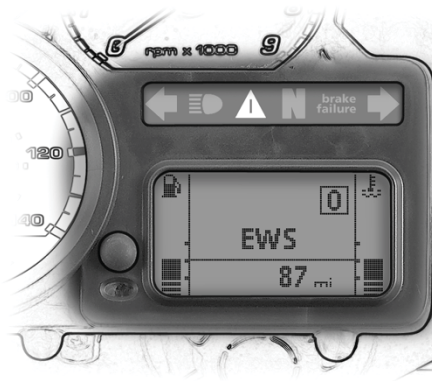



2

23

Status indicators

Warning light	Multifunction display	Meaning/measure
 yellow ON	EWS	Electronic immobilizer Key not recognized (►► 30, 31). Communication with engine electronics defective

NOTE

Various warnings may be issued simultaneously. Some warnings combine  yellow and  red, in which case the two are displayed alternately.



ABS^{OE} warning lights



2

24

Status indicators



General warning light 	ABS warning light 	Malfunctions
OFF	ON	ABS function deactivated by the rider, integral braking system available (►► 88)
OFF	Flashes at 1 Hz	ABS not available, because pull-away test not completed (►► 86)
OFF	Flashes at 4 Hz	Only RESIDUAL BRAKING FUNCTION available in both circuits, (►► 85) because self-diagnosis not completed (►► 86)
Red ON	OFF	Brake-light switch defective or not correctly adjusted
Red ON	Flashes at 1 Hz	ABS function unavailable in at least one braking circuit
Red ON	Flashes at 4 Hz	Only RESIDUAL BRAKING FUNCTION available in at least one circuit (►► 85)

Warning light, general 	Warning light, ABS 	Malfunctions
Red, alternate flashing at 1 Hz	Alternate flashing at 1 Hz	<p>Fluid level in BMW Integral ABS too low. If the functions listed below are active, maintain a defensive riding style and proceed immediately to the nearest specialized workshop, preferably an authorized BMW Motorrad retailer.</p> <ul style="list-style-type: none"> – Ignition OFF, brake pressure OK at the brake levers – Brakes acting on both wheels – Brake system leaktight, no signs of brake fluid escaping <p>Otherwise the brake system is defective: do not attempt to ride the motorcycle.</p>
Red, alternate flashing at 4 Hz	Alternate flashing at 4 Hz	<p>Fluid level in BMW Integral ABS insufficient, conduct checks listed above. Only RESIDUAL BRAKING FUNCTION available in at least one circuit (➡ 85)</p>

WARNING

Do not ride the motorcycle if you have any doubts about the safety of the brake system.

Ignition switch and steering lock

Electronic immobilizer (EWS)

Hazard warning flashers

On-board computer

Kill switch

Heated handlebar grips^{OE}

Setting the clock

Adjusting the windshield

Handlebar levers

Lights

Seat

Mirrors

Spring preload

Ignition switch and steering lock

3

28

Operation

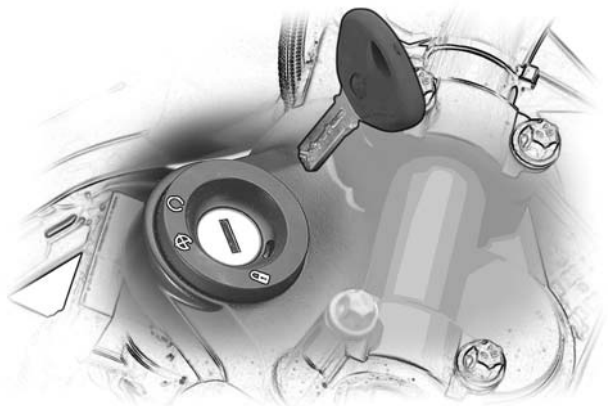

⚠ WARNING

If the motorcycle is fitted with BMW Integral ABS^{OE}, only **RESIDUAL BRAKING FUNCTION** is available when the ignition is switched off (➔ 85)

🔑 NOTE

Ignition switch and steering lock, tank lock and seat lock are actuated with the same key. On request, system cases^{OA} can be arranged to lock with the same key.

Keys

You will receive two master keys and one spare key.

Ignition switch and steering lock

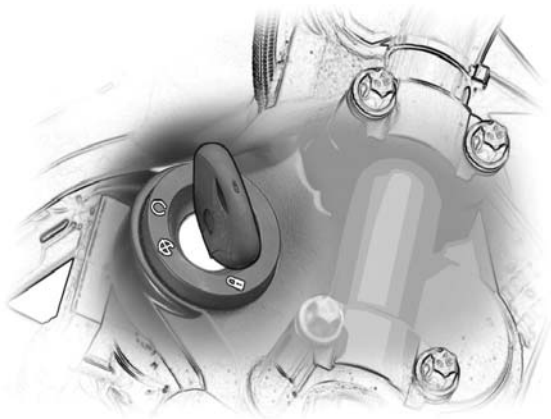



Key positions

⚠ WARNING

Do not switch over to  position while driving!

 *Ignition and lights off, steering lock engaged.

-  Operating position; ignition, parking light and all circuits switched on, predrive check is performed (➡ 64)
-  * Ignition and lights off, steering not locked (handlebars can be turned freely to left or right)

⚠ CAUTION

Turn the handlebars all the way to the left before engaging the steering lock.

NOTE

Switch the parking light on only for limited periods. Note state of battery charge.

* The key can be removed in these positions

Electronic immobilizer (EWS)

3

30

Operation

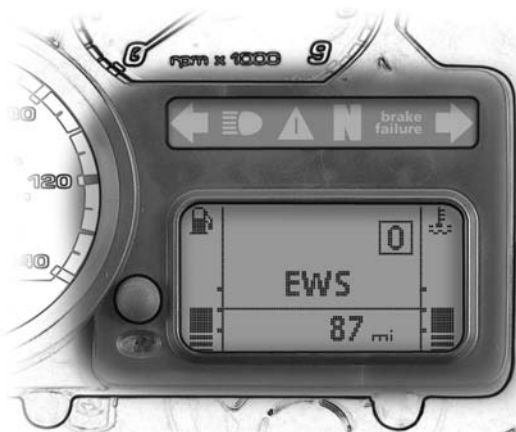

In-key security

The electronic immobilizer helps protect your BMW motorcycle from theft, and this enhanced security is at your disposal without any need for you to set parameters or activate additional systems. The engine of a motorcycle fitted with this electronic immobilizer can be started only with the keys that belong to the vehicle. You can also have your authorized BMW Motorrad retailer bar individual keys, for example if a particular key goes missing. The engine cannot be started with a key that has been barred.

Function

An electronic component is integrated into each of your keys.

The motorcycle's electronics exchange certain continuously changing signals with the electronics in the key; these signals are specific to your motorcycle and they are transmitted by the ignition switch. Ignition, fuel supply and starter are not enabled for starting until the key has been recognized as "authorized" for your motorcycle.

NOTE

A spare key attached to the same ring as the ignition key used to start the engine could “irritate” the electronics, in which case the enabling signal for ignition, fuel supply and starter is not issued. Under these circumstances the motorcycle will refuse to start. Consequently, always keep the spare key or keys separate from the ignition key. Similarly, physical force could damage the ignition key's integral electronics. If this happens, you will not be able to start the engine.

Spare/extra keys

You can obtain spare/extra keys only through an authorized BMW Motorrad retailer. The keys are part of an integrated security system, so the retailer is under an obligation to check the legitimacy of all applications for spare/extra keys.

NOTE

If you want to have a key barred, you have to bring along all the keys that belong to the motorcycle. A key that has been barred can subsequently be cleared and reactivated for use.

Hazard warning flashers

3

32

Operation

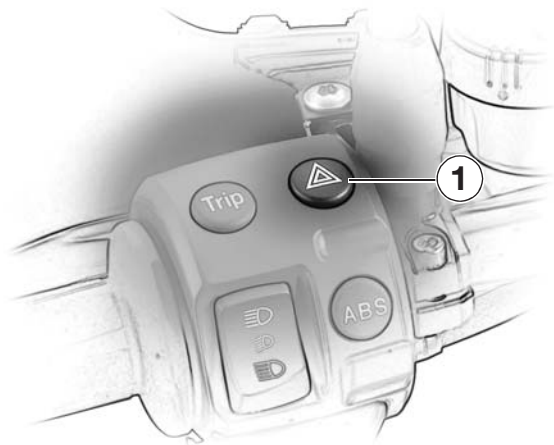

Hazard warning flashers

NOTE

You cannot activate the hazard warning flashers if the ignition is switched off.



Do not use the hazard warning flashers for longer than absolutely necessary.

Note state of battery charge.

Switching on hazard warning flashers

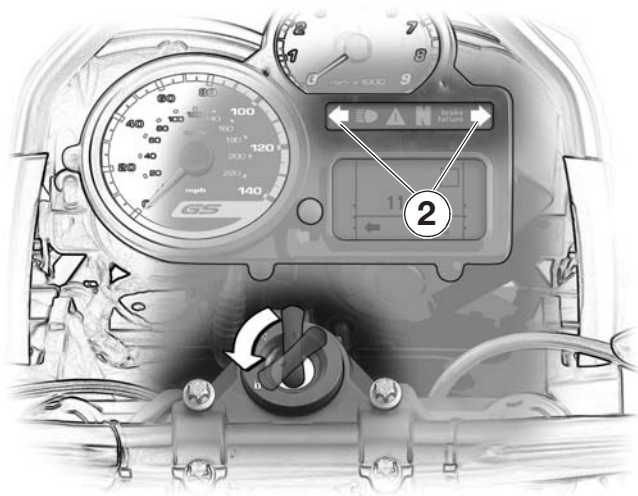
- Switch on the ignition, ignition key in the  position
- Hazard warning flasher switch **1** lights up
- Operate hazard warning flasher switch **1**
- Hazard warning flashers in operation
- Left/right flashing turn indicator lights **2** in the indicator light panel flash



- Switch off the ignition, and with the ignition key in the  position, the hazard warning flashers continue to flash
 - Left/right turn indicator lights **2** in indicator light panel go out
- Turn the handlebars to the position for locking the steering and lock the steering, turn the ignition key to 
 - The hazard warning flashers continue to operate

Switching off hazard warning flashers

- Actuate hazard warning flasher switch **1** or switch on ignition
 - Hazard warning flashers cease to operate

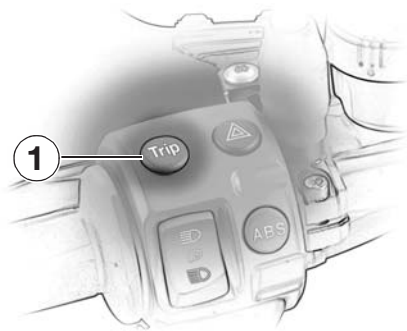

NOTE

You can activate the Tripmaster only when the ignition is switched on, in other words when the ignition key is in the  position.

When you switch on the ignition, the information shown by the Tripmaster when the ignition was switched off always reappears on the multifunction display.

- Each time you briefly press button **1** on the left handlebar fitting, you step from one function to the next in the following sequence:
 - **A** Total distance covered
 - **B** Tripmeter reading 1
 - **C** Tripmeter reading 2
 - **D** Residual range

Residual range

This reading appears only when the fuel level drops to reserve. The range is estimated on the basis of style of riding and taking the remaining supply of available fuel into account.

If the motorcycle is resting on its side stand the level in the tank cannot be measured correctly, so this estimate of residual operating range will be inaccurate.

The display shows residual range in km or miles (depending on the national-market version). Also observe the reading of fuel-level gauge **2** ( 19, 79).

The Tripmaster registers that you have refueled when approximately 3.2 qt (3 liters) have been added.

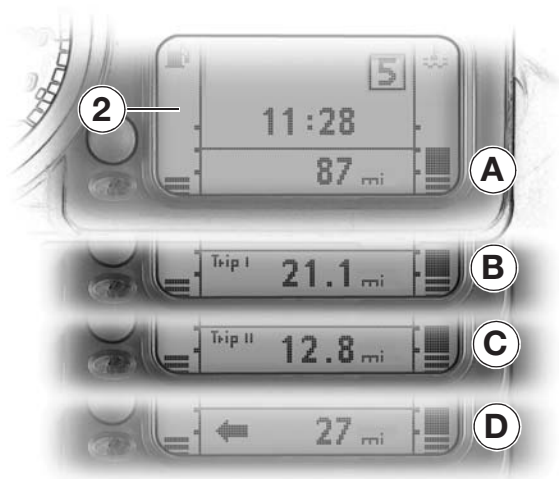

Resetting Tripmeter

- Only when the motorcycle is at a standstill and the ignition switched on, in other words when the ignition key is in the \bigcirc position
- Repeatedly press button **1** (Trip) for less than 2 seconds until
 - **B** Tripmeter reading 1 **Trip I** or
 - **C** Tripmeter reading 2 **Trip II** appears in the display
- Press button **1** (Trip) for longer than 2 seconds
 - Reading is reset to zero

Kill switch

3

36

Operation

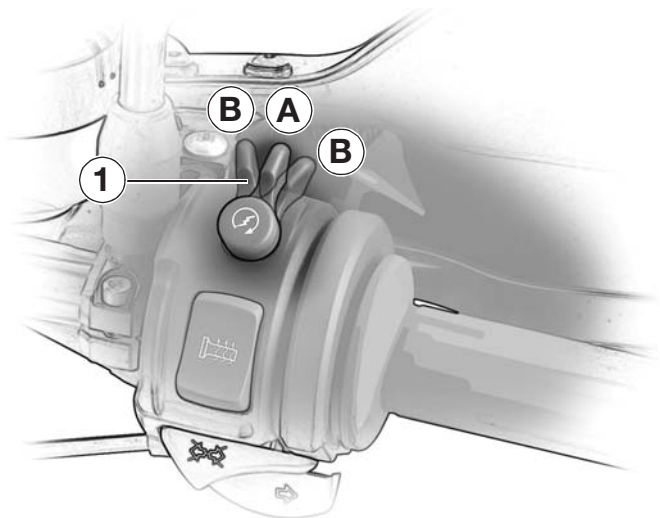

Operating the kill switch

In an emergency only:

- Move switch **1** to the **B** position
- The electrical circuits for the electronic engine management system, instrument panel, fuel pump and starter motor are de-energized

NOTE

If you move the kill switch to position **B** while the ignition is on (switch in the \bigcirc position), the BMW Integral ABS^{OE} remains operational (► 82-89).

Heated handlebar grips^{OE}

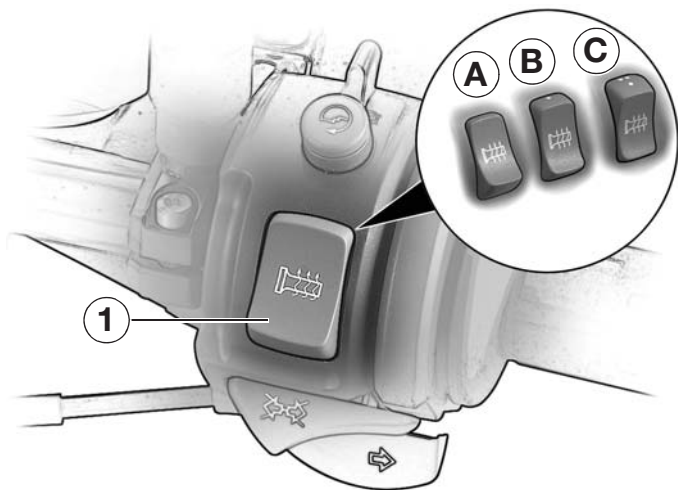

Actuating heated handlebar grips

NOTE

The grip heating is only active with the engine running. The increase in power consumption can drain the battery if you are riding at low engine speeds.

- Operate switch for heated handlebar grips **1**

- A** Heating function OFF
- B** 50% (center position)
- C** 100%

Clock

3

38

Operation

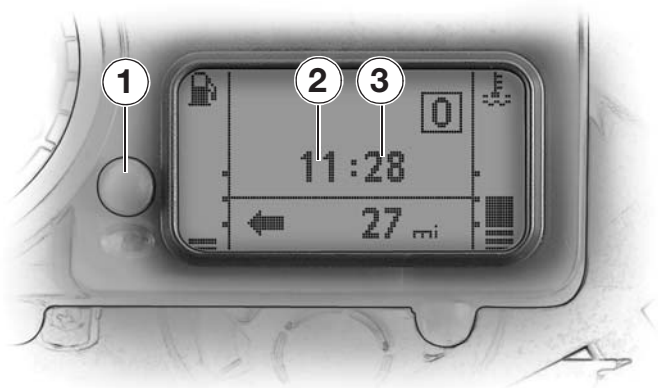

Setting clock

⚠ WARNING

Do not attempt to set the clock unless the motorcycle is at a standstill
– Risk of accident

- Ignition switch in the \bigcirc position
 - Press button **1** for longer than 2 seconds, until the clock enters set mode
 - Hours reading **2** starts flashing: briefly press button **1** to set
 - Press button **1** again for longer than 2 seconds
 - Minutes reading **3** starts flashing: briefly press button **1** to set
 - Press button **1** again for longer than 2 seconds to exit set mode
- Set mode is automatically exited if 20 seconds elapse without the button being pressed.

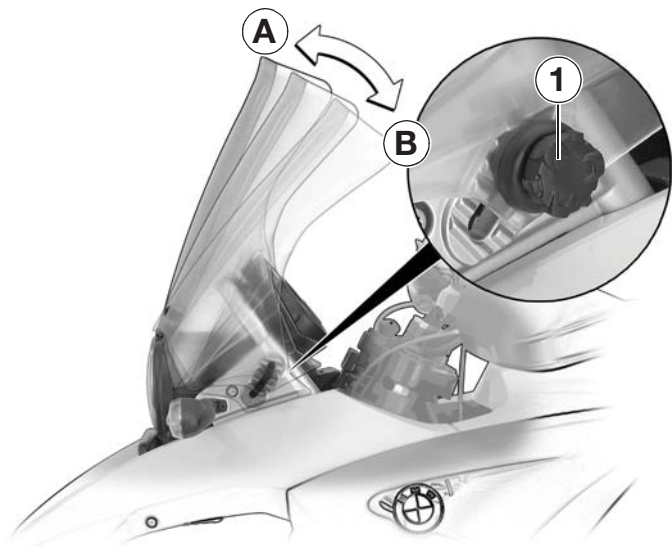

Adjusting windshield

CAUTION

Always be sure to adjust clamping screws **1** on left and right symmetrically and hand-tighten the screws.

- Slacking clamping screws **1** on left and right until the windshield can be adjusted

NOTE

You can set the windshield to any of six different positions.

- Move the windshield in the **A** or **B** direction
- Carefully retighten clamping screws **1** on left and right

Handlebar levers

3

40

Operation

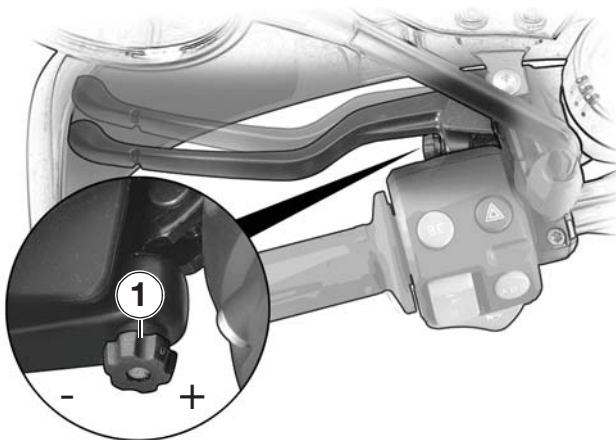

Clutch lever, adjusting

⚠ CAUTION

Sudden changes in the amount of play at the lever or a spongy feeling when it is applied may indicate a fault in the hydraulic system.

If you are doubtful about the reliability of the hydraulic clutch operating system consult a specialized workshop, preferably an authorized BMW Motorrad retailer.

⚠ WARNING

Do not attempt to turn adjusting screw 1 while riding the motorcycle.

- Turn adjusting screw **1** to set the most comfortable span:
 - Turn clockwise: to increase span
 - Turn counter-clockwise: to reduce span

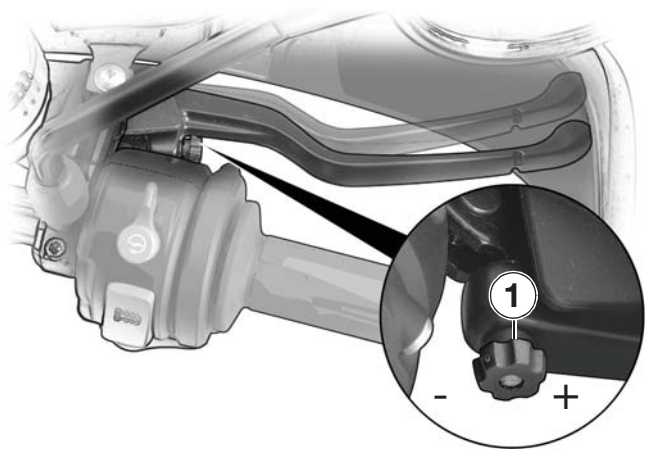

Adjusting handbrake lever

⚠ WARNING

Do not attempt to turn adjusting screw 1 while riding the motorcycle.

- Turn adjusting screw **1** to set the most comfortable span:
 - Turn clockwise: to increase span
 - Turn counter-clockwise: to reduce span

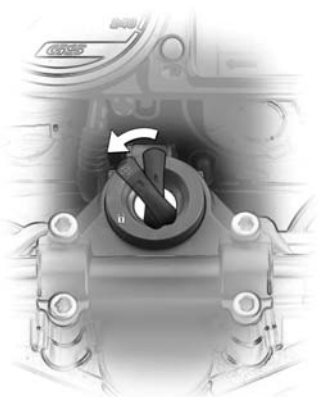

Switching on parking light

NOTE

You can switch on the parking light only immediately after switching off the ignition, when the ignition key is in the  position.

- Switch off the ignition
- Press left turn indicator switch
 - The parking light is on

Switching on low-beam head light

The low-beam head light switches on automatically when you start the engine.

Switching off the parking light

- Switch the ignition on and off again
 - The parking light is off

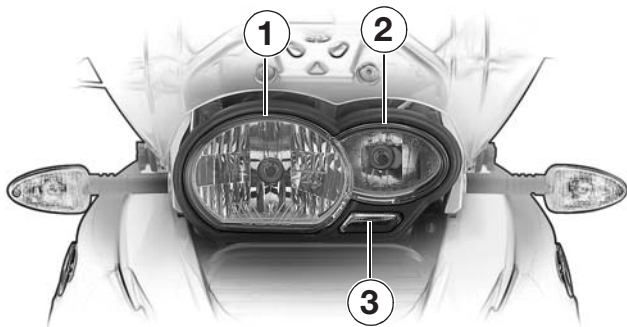



Checking lights

CAUTION

Always check that all lights are in full working order before riding off.

NOTE

If turn indicator repeater flashes at twice the usual speed: Defective flasher bulb.

Similarly, general warning light  and warning indicator  in the multifunction display ( 19) both light up notify you if a bulb fails.

- 1** Low-beam head light
- 2** High-beam headlight
- 3** Parking light

For instructions on changing bulbs for parking light, high-beam/low-beam head lights, rear light, brake light and flashing turn indicators, ( 133-139).

Headlight setting RHD/ LHD traffic

If the motorcycle is ridden in a country where the opposite rule of the road applies, its asymmetric low beam will tend to dazzle oncoming traffic.

Consult a specialized workshop, preferably an authorized BMW motorcycle retailer, to have the headlight adjusted to suit whichever rule of the road applies.

CAUTION

Adhesive films with unsuitable adhesives can damage the headlight lens.

Headlight beam throw adjustment

NOTE

Headlight beam throw is kept constant when spring preload is adjusted to suit load. For instructions on adjusting spring-strut and shock-absorber settings to suit load, (→ 50-52).

Consult a specialized workshop, preferably an authorized BMW motorcycle retailer, if you are unsure whether the headlight basic setting is correct.

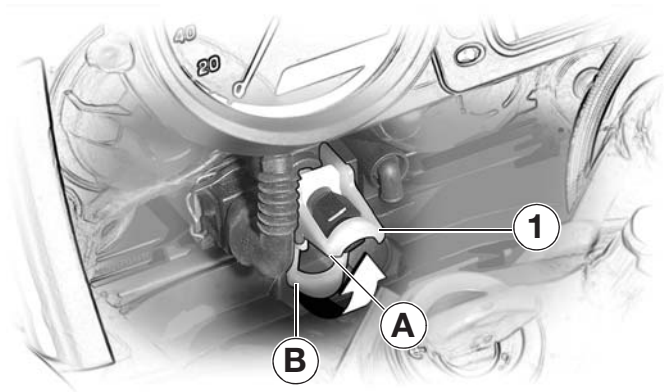

Headlight setting with motorcycle heavily loaded

Only if the load carried on the motorcycle is very high, the headlight beam can also be lowered by moving pivot lever **1**. This shortens the beam throw.

Pivot lever **1**:

A = neutral position

B = high load

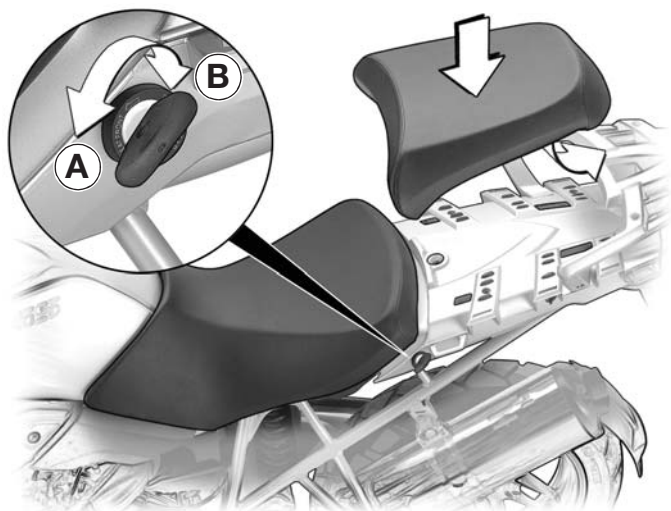

Removing seat

NOTE

You must remove the rear seat before the front seat can be removed.

If it is difficult to turn the key in direction **A**, apply firm pressure on the driver's seat for support.

- Turn the key in the seat lock to position **B**
 - Remove the rear seat
 - Turn the key in the seat lock to position **A**
 - Pull front seat to the rear and remove.
- Toolkit, Rider's Manual and battery are accessible

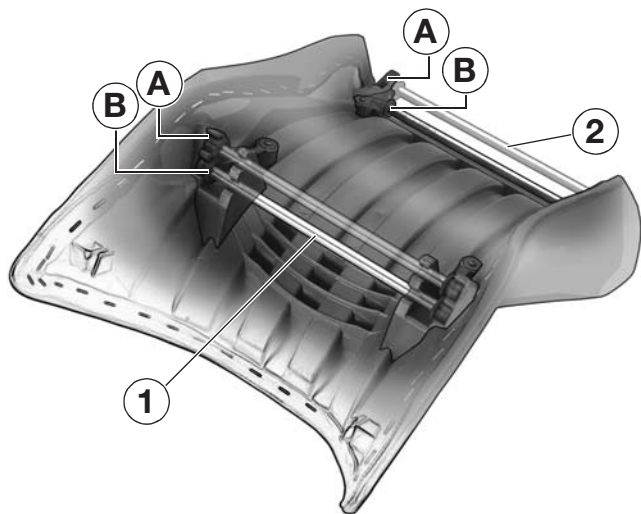

Adjusting seat

CAUTION

Front and rear retainers **1** and **2** for height adjustment must always both be set to the same height. Never set retainer **1** to the high position and retainer **2** to the low position, or vice versa.

- Remove the rear seat
 - Remove the front seat and turn it upside down
- The front seat can be set to either of two positions by means of retainers **1** and **2**:

A = high

B = low

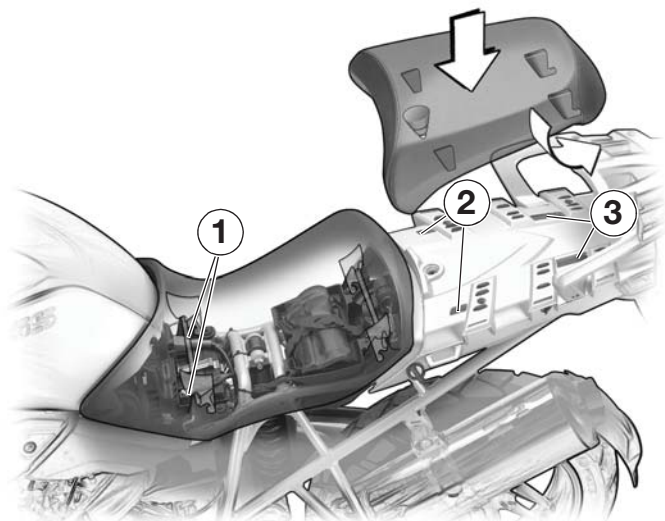

Installing seat

⚠ WARNING

When installing, make sure that front and rear seats are firmly located.

- Set the front seat to the desired height (➡ 47)
- Slide the front seat into front lock **1** and press firmly on the seat to secure it

🔧 NOTE

Toolkit must be packed as flat as possible.

- Engage the rear seat in rear retainers **3** first, and then in front retainers **2**
- Press firmly to engage the seat

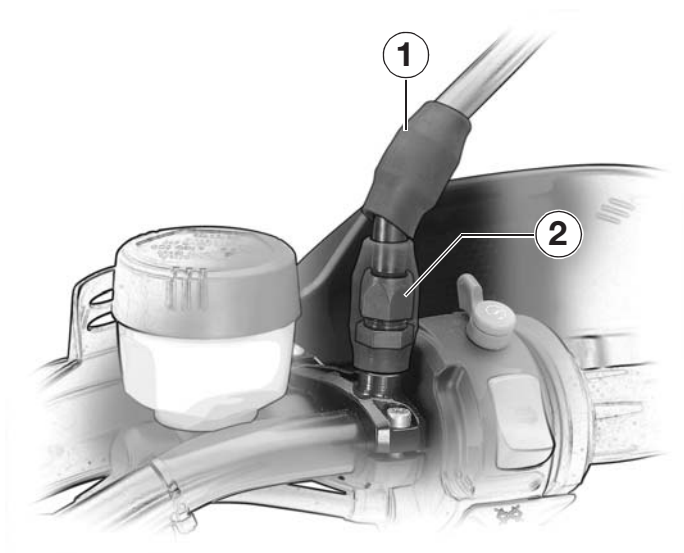

Adjusting mirrors

Simply turn the mirrors to adjust them:

- Grip the mirror by the edge of the glass and
- turn it to the desired position

Adjusting mirror arms

In order to improve ergonomics or if a mirror arm has worked loose:

- Push back protective cap **1** on the threaded fastener of the left or right mirror arm, as applicable
- Loose union nut **2**
- Turn the left or right mirror arm to the desired position
- Retighten union nut **2**
- Pull protective cap **1** back into position concealing the threaded fastener

Spring preload

3

50

Operation

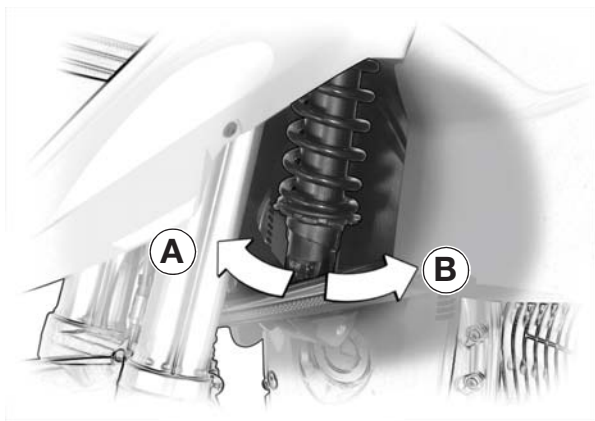

⚠ WARNING

Before starting off, adjust spring preload to suit the surface on which you intend riding.

Check and correct the tire pressures (➔ 53).

Adjusting spring preload of front wheel

- Make sure the ground is level and firm and lift the motorcycle onto its main stand

- Adjust preload of spring to a stage between 1 and 9:
3rd stage – paved road
5th stage – loose gravel or similar
9th stage – off-road

Fine-tune the setting in accordance with your personal preferences.

🔧 NOTE

Stage 1:

Turn all the way in the direction indicated by **A**

Stage 9:

Turn all the way in the direction indicated by **B**

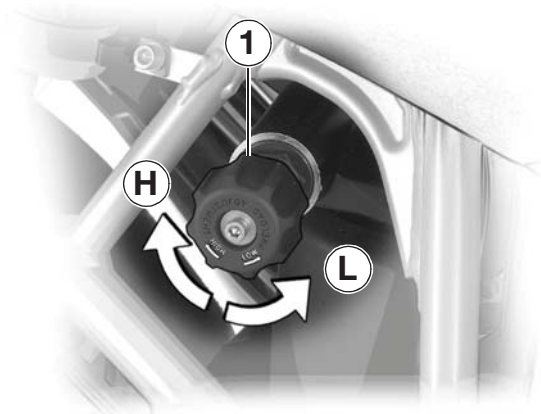

WARNING

Before starting off, adjust spring preload to suit the gross weight of the motorcycle and the surface on which you intend riding.

Check and correct the tire pressures (➔ 53).

For safety reasons, never attempt to alter spring preload while the motorcycle is being ridden.

Always bring the motorcycle to a stop before adjusting.

Adjusting spring preload of rear wheel

LOW setting (one-up):

- Turn knob **1** as far as it will go counter-clockwise in **LOW** direction (**L**) as indicated by arrow.
- Then turn it ten clicks clockwise

HIGH setting (for off-road use, or two-up with luggage)

- Turn knob **1** as far as it will go clockwise in **HIGH** direction (**H**) as indicated by arrow.

Fine-tune the setting in accordance with your personal preferences.

Shock-absorber adjustment

3

52

Operation

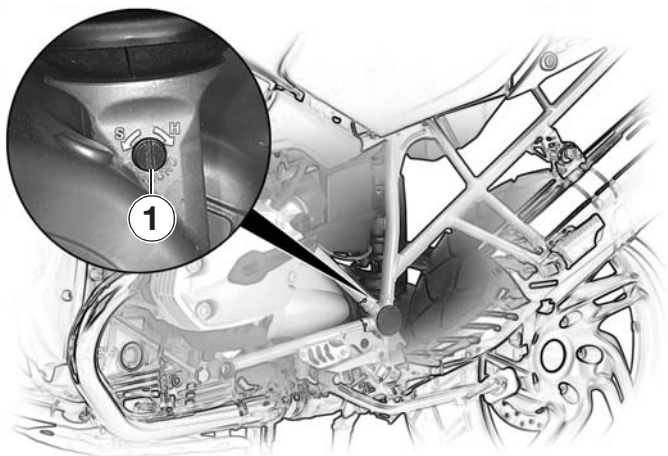

⚠ WARNING

Before starting the journey, adjust the shock absorber to match total weight.

If spring preload is changed, it is essential to adjust the shock-absorber setting accordingly (and vice versa).

- Make sure the ground is level and firm and lift the motorcycle onto its main stand
- Adjust the rear shock absorber

Basic setting (one-up):

- Turn adjusting screw **1** as far as it will go clockwise in the direction indicated by the **H** arrow
- Turn adjusting screw **1** one and a half turns counter-clockwise in the direction indicated by the **S** arrow

Hard setting “H”:

- Turn adjusting screw **1** as far as it will go clockwise in the direction indicated by the **H** arrow

Soft setting “S”:

- Turn adjusting screw **1** as far as it will go counter-clockwise in the direction indicated by the **S** arrow

Checking tire pressures

WARNING

Incorrect tire pressures have a considerable influence on handling and on tire life.

Adjust tire pressures to suit total weight. Never exceed either the motorcycle's gross weight or the individual wheel load limits (► 55).

Tires cold:

- Unscrew and remove valve cap
- Check/correct tire pressure
- Screw the valve caps back on tightly

Tire pressures for road tires and massive-bar tires:

	front	rear
One-up	31.9 psi (2.2 bar)	36.3 psi (2.5 bar)
Two-up or luggage	36.3 psi (2.5 bar)	42 psi (2.9 bar)
passenger and luggage	36.3 psi (2.5 bar)	42 psi (2.9 bar)

Screw the valve caps back on tightly

WARNING

At high road speeds, tire valves have a tendency to open as a result of centrifugal force.

Use only metal valve caps with rubber seals.

Valve caps that are screwed on well prevent air from escaping suddenly.

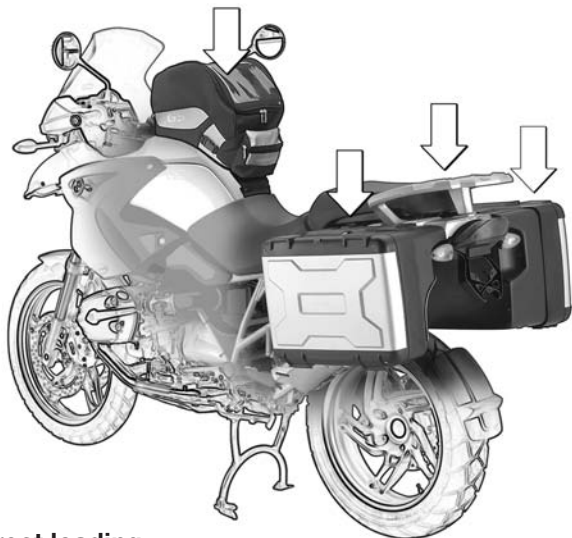

Correct loading

⚠️ WARNING

Overloading can impair the handling of your motorcycle.

- Make sure that the weight is uniformly distributed between right and left
- Pack heavy items at the bottom and toward the inboard side
- Maximum load in each case^{OA} left and right: approx. 22 lbs (10 kg)
- Maximum load in tank-top rucksack^{OA} and topcase^{OA} max. approx. 11 lbs (5 kg) each
- Check that fastenings are correctly positioned and tight

⚠️ WARNING

With cases installed, it is advisable not to exceed 80 mph (130 km/h).

⚠ CAUTION

Do not exceed the gross weight limit of 937 lbs (425 kg)

Do not exceed the wheel load limits of 375 lbs (170 kg) at the front and 617 lbs (280 kg) at the rear.

Adjust shock absorbers front and rear, rear-wheel spring and tire pressures to suit total weight (► 50-, 53).

The total weight is the sum of:

- motorcycle with full tank
 - rider
 - passenger
 - luggage
-

Shift lever

3

56

Operation

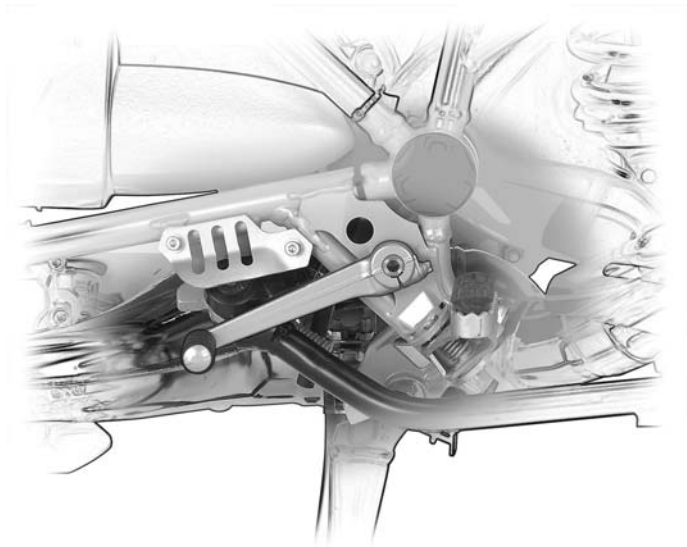

⚠ WARNING

For safety reasons, do not attempt to change the position of the shift lever.

If you would like settings changed to suit your personal preferences, please contact a specialized workshop, preferably your authorized BMW motorcycle retailer.

Safety instructions

Checklist

First time out

Before you start

Starting

Running in

Shifting gear

Off-road riding

Parking

Refueling

Brake system - general

BMW Integral ABS^{OE}

Motorcycle equipped with BMW Integral ABS (➔ 82-89)

⚠ WARNING

When the ignition is switched off or if the BMW Integral ABS fails, only a RESIDUAL BRAKING FUNCTION remains available for slowing the motorcycle (➔ 85).

Under these circumstances you must apply CONSIDERABLY higher pressure to the brake levers in order to apply the brakes, and lever travel is longer.

Risk of poisoning

Exhaust fumes contain carbon monoxide, which is colorless and odorless but highly toxic.

⚠ WARNING

Inhaling exhaust fumes therefore represents a health hazard and can even cause loss of consciousness with fatal consequences.

Do not run the engine in an enclosed space.

Risk of fatal accident

Your motorcycle is equipped with digital engine electronics and a high-power ignition system.

⚠ WARNING

When the engine is running or the ignition switched on, never touch electrically live parts of the ignition system or the digital engine electronics.

Catalytic converter

CAUTION

To avoid damage to the catalytic converter:

- Do not run the fuel tank dry
- Do not run the engine with a spark-plug lead disconnected
- Do not exceed the engine-speed limits marked on the tachometer
- Comply with all specified maintenance intervals
- Stop the engine at once if it is misfiring
- In the event of misfiring or a severe drop in engine power, consult a specialized workshop, preferably an authorized BMW Motorrad retailer.

If misfiring or malfunction of the fuel-air mixture preparation system causes unburned fuel to reach the catalytic converter, there is a risk of it overheating and being damaged.

Risk of fire

High temperatures occur at the exhaust system, particularly if a catalytic converter is installed.

WARNING

Make sure that whether riding or standing still or when the motorcycle is parked, no easily flammable material (for example hay, grass, leaves, clothing or luggage etc.) can come into contact with the hot exhaust system. Do not allow the engine to idle unnecessarily or for prolonged periods of time – risk of overheating or fire! Ride away immediately after starting the engine.

Use the safety checklist – before every journey

Please perform the safety check accurately. If your motorcycle needs any routine maintenance, you may be able to attend to it before the journey starts, see the chapter entitled Maintenance in this manual, or you can have it performed by a specialized workshop, preferably your authorized BMW Motorrad retailer.

This is to ensure that your motorcycle complies with road-vehicle use and safety laws. Your vehicle must be in perfect technical order: this is a basic prerequisite for your safety and the safety of other road users.

Checklist

- Fuel level
 - Positions of the handlebar levers
 - Brakes
 - Brake fluid level
 - Clutch fluid level
 - Warning lights and indicator lights
 - Lights
 - Shock-absorber setting and spring preload
 - Condition of wheels and tires, tread depth and tire pressures
 - Load, gross weight
 - Check secure hold of luggage system
 - Check regularly (every time you stop for fuel):
 - Engine oil level (every second/third stop for fuel):
 - Brake pads
- If you encounter any problems or difficulties, it is always best to contact your authorized BMW motorcycle retailer. He will provide the necessary advice and assistance.

Handling your motorcycle safely

Each motorcycle has a character all its own. It is time now for you to familiarize yourself with the way your own motorcycle behaves:

- acceleration
- roadholding
- cornering
- braking ...

These are all things you need to become familiar with.

Please remember too that if the motorcycle has not yet covered 1,000 kilometers (approx. 600 miles), the engine is not yet fully run in.

CAUTION

BMW Integral ABS^{OE} incorporates a brake booster, so braking efficiency is significantly higher than with conventional brake systems.

If you ride at high speed, always bear in mind that various boundary conditions such as the spring preload setting and the shock absorber setting, an unbalanced luggage load, loose clothing, low tire pressure, poor tire tread, and so on, can affect the handling of your motorcycle.

Safe motorcycling doesn't depend on the motorcycle alone.

Your own skill and common-sense are needed too.

The key to genuine safety on the road is a sensible balance between the motorcycle's technical features and the rider's skill, so that together they form a single efficient unit.

Riding safely in traffic and off-road calls for a sense of responsibility to your passenger and to other road users.

WARNING

Do not ride the motorcycle after drinking alcoholic beverages. Even small amounts of alcohol or drugs, particularly if taken in conjunction with medicines, will adversely affect your perception and your ability to assess situations and make decisions, and also slow down your reflexes.

Take to the road now by all means, but think carefully about everything you do.

Before you start

4

64

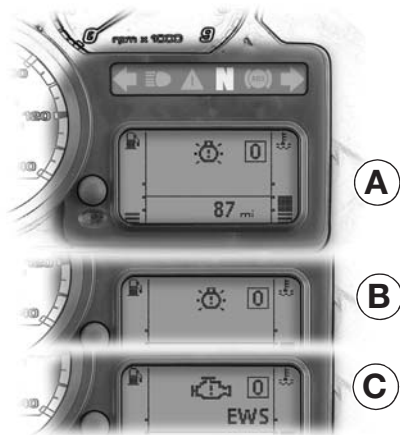

Riding



Predrive check

A predrive check is performed when you switch on the ignition, in other words when the ignition switch is in the  position. All the warning lights come on briefly and then go out again.

The multifunction display shows the following in the order in which they are described below:

- Phase 1, **A**, with General warning light 
- Phase 2, **B**, with General warning light 
- Phase 3, **C**, without General warning light 

Once the predrive check completes, the various gauges and indicators in the instrument panel show their current values.

NOTE

The predrive check is aborted if you start the engine before it completes.

ABS self-diagnosis

If the motorcycle is fitted with BMW Integral ABS^{OE}, the ABS performs self-diagnosis ( 86).

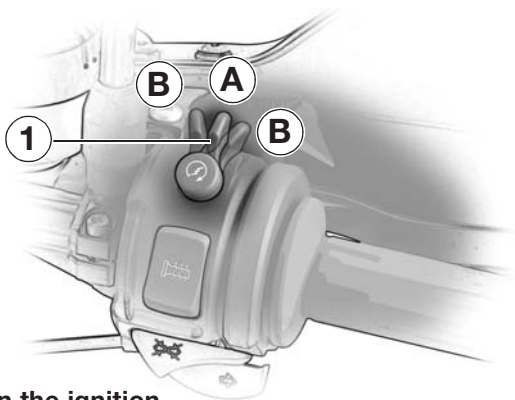

Switching on the ignition

- See the notes on the electronic immobilizer (EWS) (➡ 30)
- Move the kill switch **1** to the run position **A**
- Ignition switch in the  position
- Predrive check is performed
- ABS self-diagnosis is performed

WARNING

ABS^{OE} self-diagnosis is not performed unless both brake levers are in their fully released positions.

Only the RESIDUAL BRAKING FUNCTION is available until self-diagnosis is completed (➡ 85).

NOTE

Starting on gradients:
Always switch on the ignition with gear engaged, clutch lever released and both brake levers released.

Self-diagnosis cannot be performed if you do not follow this procedure.

When self-diagnosis completes, apply the brakes, disengage the clutch, and start the engine.

Before you start

4

66

Riding

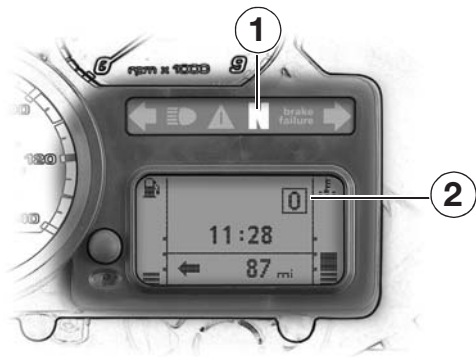

Fully retract side stand

NOTE

If the side stand is extended and a gear engaged, you cannot start the motorcycle.

Selecting neutral

- Neutral indicator light **1** **green**  lights up and gear indicator **2** in the multifunction display shows **0**.

NOTE

Engine does not start:

- Move the gear lever to the  position or
- Do not pull the clutch lever until after you switch on the ignition

Engine stops when first gear is engaged:

- Fully retract the side stand; if necessary consult the troubleshooting chart ( 109)

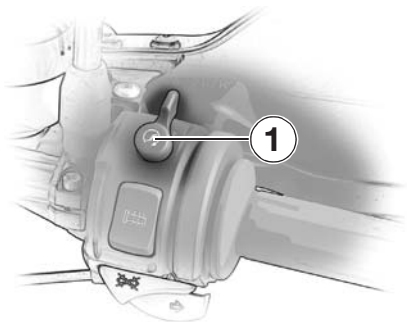

Starting

CAUTION

Do not allow the engine to idle unnecessarily or for prolonged periods of time

– risk of overheating or fire.

Ride away immediately after starting the engine.

To avoid overheating the air-cooled engine and possible damage as a result, avoid even short warming-up periods at a standstill.

Avoid high engine speeds after a cold start.

NOTE

The start attempt is automatically interrupted if battery voltage is too low.

Before trying again: recharge the battery.

NOTE

Do not turn the throttle twistgrip when starting the engine.

At ambient temperatures below 32 °F (0 °C), switch on the ignition and pull the lever to disengage the clutch when starting the engine.

- Press starter pushbutton **1**
 - The engine will then start
- Observe instruments and display for warnings and information (► 20-25)



Running-in engine speeds From 0 to 600 miles (1,000 km)

- Engine speed max. 4,000 rpm and no full-load acceleration
- The first inspection should always be performed after approx. 300 to 700 miles (500 to 1,200 km).

Make an appointment with your authorized BMW Motorrad retailer in good time, so that the work can be performed punctually.

CAUTION

Exceeding the specified engine speeds while running in will lead to increased engine wear.

NOTE

While running in the motorcycle, vary the throttle opening and engine-speed range frequently. Try to do most of your riding during this initial period on twisting, fairly hilly roads rather than high-speed main roads and highways.

From 600 to 1,200 miles (1,000 to 2,000 km)

- Engine speeds can be gradually increased after 600 miles (1,000 km)
- Avoid lengthy periods at full load until approx. 1,200 miles (2,000 km) have been covered

Brake pads: running in

WARNING

New brake pads must “bed down” and therefore do not achieve their optimum friction levels during the first 300 miles (500 km).

This slight initial reduction in braking efficiency can be compensated for by exerting greater pressure on the lever. Try to avoid all unnecessary hard braking during this initial period.

CAUTION

Comply with the notes on BMW Integral ABS^{OE} (►► 82-89).

Tires: running in

WARNING

New tires have a smooth surface. This must be roughened by riding in a restrained manner at various heel angles until the tires are run in. **This running in procedure is essential if the tires are to achieve maximum grip.**

Shifting gears

4

70

Riding

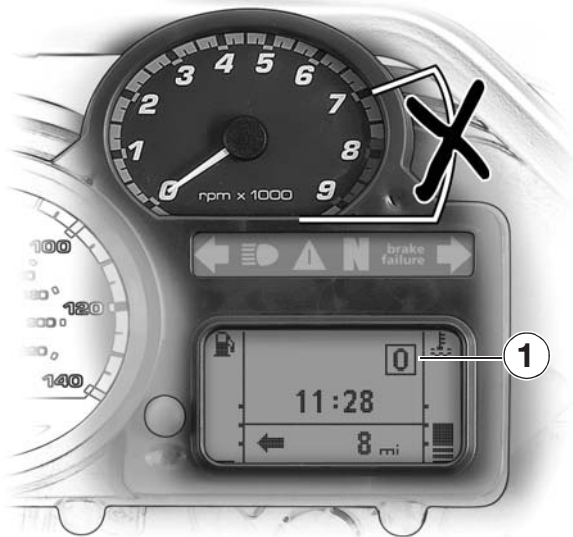

Load changes

⚠ WARNING

Try not to open or close the throttle abruptly, particularly on wet or slippery roads.

Engine speed

Do not use the high end of the engine-revolutions range in any gear unless the engine is at operating temperature

When the tachometer needle enters the red zone on the dial, the fuel supply is interrupted in order to protect the engine against over-revving.

The governor cuts in at 7,900 rpm.

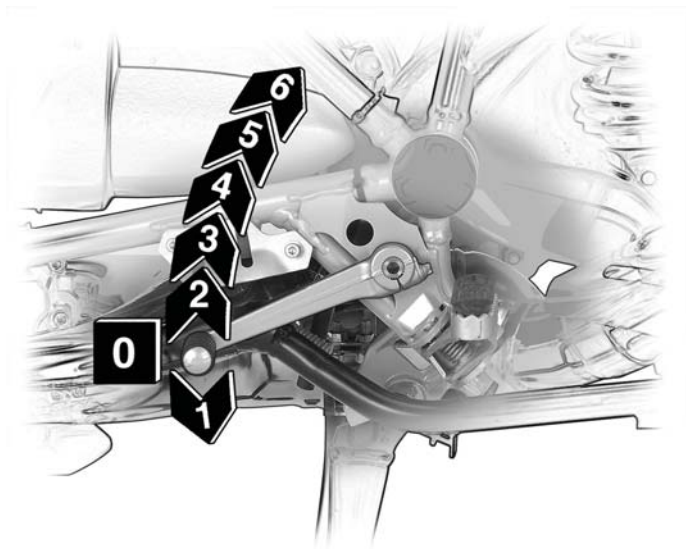

Shifting gears

CAUTION

Always disengage the clutch in order to shift gear.

NOTE

Digital gear indicator **1** in the multifunction display tells you which gear is engaged.

Wheels and tires

WARNING

If you lowered the pressure in the tires for more traction when riding off-road, remember that you must immediately reinflate the tires to the correct pressures when you return to paved roads (► 53).

CAUTION

This motorcycle is a touring Enduro machine, which means it can also be used for light off-roading on unsurfaced tracks. If you are contemplating heavy off-road usage or long trips that will involve a lot of off-road riding, it is advisable to fit cross-spoked wheels^{OE} in order to avoid damage to the cast-aluminum rims of the standard wheels.

Dirt or mud on brakes

WARNING

Dirt on the brake disks or brake pads will increase the braking distance.

The brakes must first be applied until the disks and pads are clean.

Dirt on the brakes increases the rate of pad wear.

BMW Integral ABS^{OE}

If you are riding off-road or on a loose surface, you might prefer to deactivate the ABS function. (►► 88-89).

Spring preload

CAUTION

Adjust spring preload and the shock-absorber settings before you start off-riding.

Remember to reset spring preload and the shock absorbers to the correct setting when you return to paved roads (►► 50-52).



Placing motorcycle on side stand

⚠ WARNING

For safety reasons, never sit on the motorcycle with the side stand extended.

⚠ CAUTION

Stop the engine before using the side stand.

Make sure the surface under the stand is firm.

On a grade, the motorcycle should always face uphill; select 1st gear.

- Switch off the ignition
- Pull the handbrake lever
- Hold the motorcycle upright and balanced
- Use your left foot to extend the side stand fully (arrow)
- Slowly lean the motorcycle to the side until its weight is taken by the stand and dismount from the motorcycle
- Turn the handlebars to full left lock (➡ 29)
- Check that the motorcycle is firmly supported

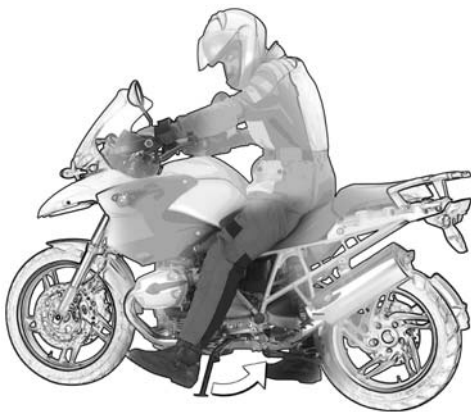



Removing motorcycle from side stand

⚠ WARNING

If the motorcycle is equipped with BMW Integral ABS^{OE} only a **RESIDUAL BRAKING FUNCTION** is available when the ignition is switched off (➡ 85).

Make sure the side stand is fully retracted before you ride off.

– **Allowing the motorcycle to roll with the side stand extended represents a safety risk.**

- Ignition key in the  or  position
 - Handlebars unlocked
- Both feet on the ground, no weight on the motorcycle
- Pull the handbrake lever
- Slowly raise the motorcycle to the upright position and keep it balanced
- Sit on the motorcycle and use your left foot to retract the side stand

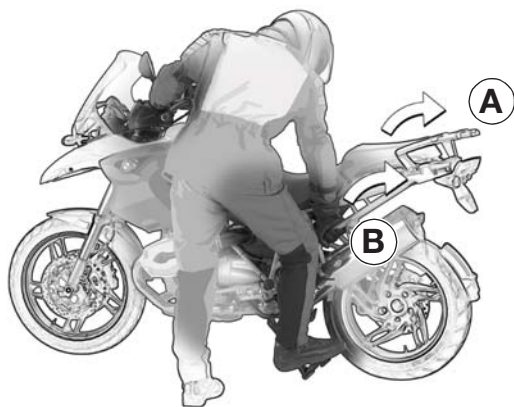

Placing motorcycle on main stand

⚠ WARNING

For safety reasons, never sit on the motorcycle with the main stand extended.

⚠ CAUTION

Stop the engine before using the main stand.

Make sure the surface under the stand is firm.

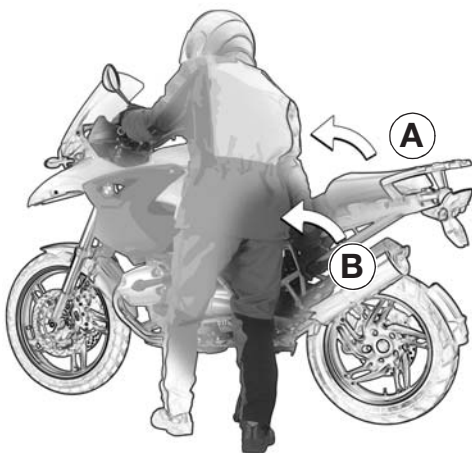

- Switch off the ignition
- Hold the left handlebar grip with your left hand
- Place your right hand on the luggage rack **A** or on the rear frame **B**
- Place your right foot on the pin of the main stand, and press the stand down until its curved feet touch the ground
- Apply all your body weight to the stand
- Pull the motorcycle to the rear and upwards (arrow) until it rests on the main stand
- Check that the motorcycle is firmly supported



Removing motorcycle from main stand

CAUTION

Make sure the main stand is fully retracted before you ride off.

- Ignition key in the  or  position
 - Handlebars unlocked
- Hold the left handlebar grip with your left hand
- Place your right hand on the luggage rack **A** or on the rear frame **B**
- Push the motorcycle forward off the main stand
- Check that the main stand has fully retracted

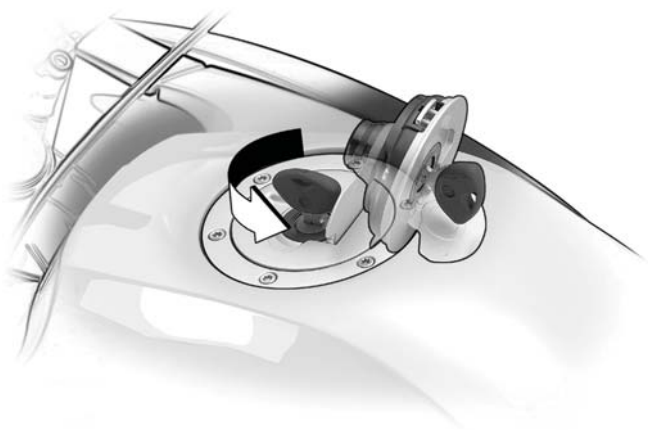

Refueling

⚠ WARNING

Fuel is flammable and explosive. Do not smoke. Never bring a naked flame near the fuel tank.

Fuel expands when hot (for instance if the fuel tank is in the sun). For this reason, only fill as far as the lower edge of the filler neck.

⚠ CAUTION

Leaded fuel will destroy the catalytic converter.

Do not run the fuel tank dry or you may damage the engine or catalytic converter.

Fuel can damage plastic parts, so make sure they are not brought into contact with fuel.

- Make sure the ground is level and firm and lift the motorcycle onto its main stand
- Open the fuel filler cap
- Refuel with fuel of the approved quality
- Close the fuel filler cap

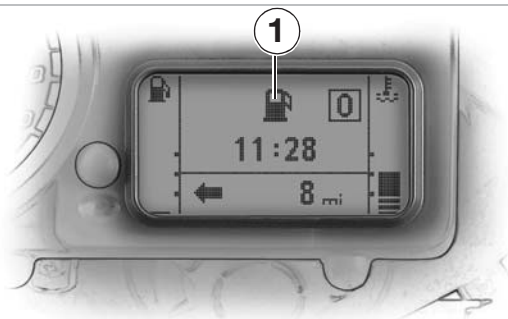

Capacity

NOTE

The fuel gauge in the multifunction display works only when the ignition is switched on, in other words when the ignition key is in the  position.

- Usable tank capacity is 5.3 gal (20 liters), including a reserve of approximately 1 gal (4 liters)

NOTE

When the reserve area is reached, the symbol **1** flashes and the  turns yellow. At this point there are about 1 gal (4 liters) of fuel left in the tank. The estimated residual operating range appears on the Tripmaster's display.

Fuel quality

The engine is designed for:

- Super unleaded gasoline (95 RON) (AKI 90)

It is preferable to use this fuel quality to comply with the nominal values for performance and fuel consumption.

In addition, the following fuel quality can also be used:

- Super Plus gasoline (98 RON) (AKI 93)

The minimum quality is:

- Regular unleaded gasoline (91 RON) (AKI 87)

It is recommended that gasoline with a fuel quality lower than (91 RON) (AKI 87) not be used

Descending mountain passes

CAUTION

There is a danger of the brakes fading if you use only the rear brakes when descending mountain passes. Under extreme conditions, the brakes could overheat and suffer severe damage.

Wet brakes

After the motorcycle has been washed, ridden through water or ridden in the rain, the brake disks and pads may be wet (or iced-over in winter), and may not take effect immediately.

WARNING

The brakes have to dry before they start to bite.

Salt on brakes

The brakes may fail to take effect immediately if the motorcycle was ridden on salt-covered roads and the brakes were not applied for some time.

WARNING

The layer of salt on the brake disks and pads must first be worn away.

Oil and grease on brakes

WARNING

Brake disks and pads must be free from oil and grease.

Dirt or mud on brakes

When riding on loose surfaces or muddy roads, the brakes may fail to take effect immediately because of dirt or moisture on the disks or brake pads.

WARNING

The brakes must first be applied until the disks and pads are clean. Dirt on the brakes increases the rate of pad wear.

WARNING

If the brake lever can be moved right to the limit of its travel, this indicates a mechanical or hydraulic fault. The brake system is defective.

Immediately consult a specialized workshop, preferably an authorized BMW Motorrad retailer.

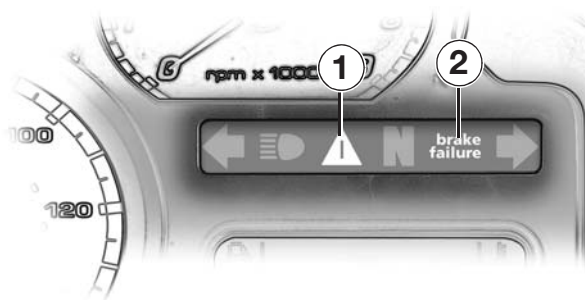

⚠ WARNING

If ABS indicator light 1 or 2 lights up, consult the **ABS troubleshooting table** (► 24-25).

Sensitive electronic control

It takes skill and sensitive control of the brakes to pull up safely on a motorcycle. If the front wheel brake locks and the wheel skids, the necessary longitudinal and lateral stabilizing forces are lost, and a fall can result.

For this reason, the rider seldom makes full use of available braking performance in an emergency.

BMW Integral ABS is the latest-generation BMW Motorrad ABS development: by preventing both wheels from locking and optimizing braking-force distribution by means of the integral function, it offers much improved braking performance (► 84). Full use is made of technical braking capacity to minimize braking distances, even when road conditions are poor. When the motorcycle is ridden in a straight line, the BMW Integral ABS is able to handle emergency braking safely.

Safety margin

But remember: the potentially shorter braking distances which BMW Integral ABS permits must not be used as an excuse for careless riding. ABS is primarily a means of ensuring a safety margin in genuine emergencies.

- You have to familiarize yourself with the new, electronically assisted braking. Try the brakes several times when you take your motorcycle out for the first time. Find out for yourself how the brakes feel.
- Take care when cornering. When you apply the brakes on a corner, the motorcycle's weight and momentum take over and even BMW Integral ABS is unable to counteract their effects.

Partially integral brakes

The integral brake function interlinks the front and rear brakes, so both wheels are braked when you operate the brake lever.

The electronic controller in the BMW Integral ABS computes the braking-force distribution between the front and rear wheels, and applies the brakes accordingly.

Braking-force distribution depends on load and is recalculated every time the ABS controller comes into action.

In this partially integral brake configuration, the integral braking function is activated only when you pull the handbrake lever. The footbrake lever acts only on the rear brake.

Brake booster

The hydraulic pump in the BMW Integral ABS actively boosts the braking force acting on the wheel when the brakes are applied.

By boosting the braking force in this way, BMW Integral ABS achieves higher braking efficiency than standard brake systems.

ABS anti-lock brake system

ABS prevents the wheels locking under heavy braking, thus contributing significantly to road safety.

RESIDUAL BRAKING FUNCTION

If the BMW Integral ABS develops a fault, only a RESIDUAL BRAKING FUNCTION is available in the brake circuits in question.

The RESIDUAL BRAKING FUNCTION is the braking efficiency without the hydraulic servo assistance of the BMW Integral ABS.

Under these circumstances, therefore, you must apply CONSIDERABLY higher pressure to the brake levers in question in order to apply the brakes, and lever travel is longer.

When the RESIDUAL BRAKING FUNCTION is active, the ABS function is unavailable in the brake system in question.

When the RESIDUAL BRAKING FUNCTION is active, the integral braking function is partially or entirely unavailable.

WARNING

When the RESIDUAL BRAKING FUNCTION is active, maintain a defensive riding style and proceed immediately to the nearest specialized workshop, preferably an authorized BMW Motorrad retailer.

NOTE

When the RESIDUAL BRAKING FUNCTION is active at the front wheel, it is advisable to set the adjuster in such a way as to permit maximum movement of the handbrake lever (► 41).

The RESIDUAL BRAKING FUNCTION is active under the following circumstances:

- Ignition off
- Before and during self-diagnosis (► 86)
- Fault in the BMW Integral ABS (► 24-25)

NOTE

When the RESIDUAL BRAKING FUNCTION is active for both brake circuits, the noise of the pump is no longer audible when you operate the brake levers.

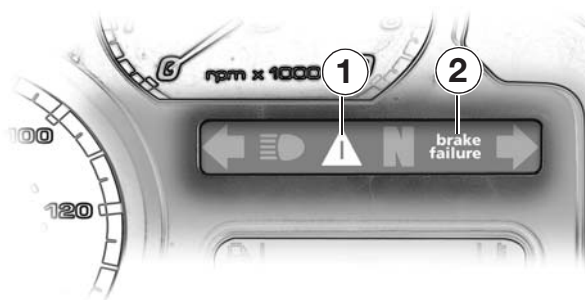

Self-diagnosis with pull-away test

The BMW Integral ABS performs self-diagnosis and a pull-away test to ensure its operability.

Self-diagnosis is performed automatically when you switch on the ignition.

⚠ WARNING

Self-diagnosis is not performed unless both brake levers are in their fully released positions.

Only the RESIDUAL BRAKING FUNCTION is available until self-diagnosis is completed (➡ 85).

- Release the brake levers, if necessary
- Switch on the ignition

Initially:

- ABS warning light **2**: flashes at 4 Hz
- General warning light **1**: ON

➡ Self-diagnosis is in progress

Then:

- ABS warning light **2**: flashes at 1 Hz
- General warning light **1**: OFF

➡ Self-diagnosis successfully completed

- Start the engine.
- Move off
- ABS warning light **1**:
OFF (as of approx. 3 mph
(5 km/h) road speed)
- ▶▶ Pull-away test successfully
completed
- ▶▶ BMW Integral ABS
is available

 NOTE

Flashing at 1 Hz = 1 flash per
second (slow flashing)

Flashing at 4 Hz = 4 flashes per
second (fast flashing)

 NOTE

Starting on gradients:
Always switch on the ignition
with gear engaged, clutch lever
released and both brake levers
released.

Self-diagnosis cannot be per-
formed if you do not follow this
procedure.

When self-diagnosis com-
pletes, apply the brakes, disen-
gage the clutch, and start the
engine.

Off-road deactivation

In contrast to road riding, when BMW Integral ABS should always be active in order to prevent wheel lock and a resulting accident, it may be desirable to dispense with ABS when riding off-road or on a loose surface. This is the reason why the ABS function of BMW Integral ABS can be deactivated.

Deactivating ABS

WARNING

Never switch the ignition off and on unless the motorcycle is at a standstill.

Brake boost and the integral function remain operational, even if the ABS function is deactivated.

NOTE

The ABS function is reactivated once the self-diagnosis routine has completed successfully after you switch off the ignition and switch it on again with the motorcycle at a standstill.

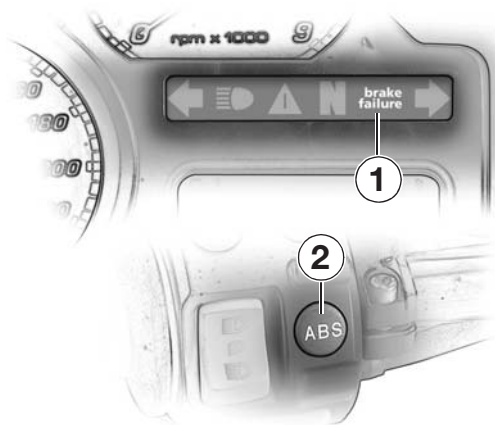

⚠ WARNING

When the ABS function is deactivated – as indicated by the ABS warning light 1 – the safety reserves normally offered by the anti-lock braking system are not available until the ABS function is reactivated.

There is a risk of dropping the motorcycle if the brakes are applied too hard and the front wheel locks or the rear wheel lifts clear of the ground as a result of a high level of front tire adhesion.

- With the motorcycle at a standstill, switch off the ignition
- Press and hold down ABS button **2**
- Switch on the ignition
- Release ABS button **2**
- ABS warning light **1** remains ON
- The ABS function is deactivated
- Warning light **1** remains permanently on to remind you that ABS has been deactivated

General instructions

12 V sockets

Luggage system

NOTE

BMW accessories and BMW-approved products can be obtained from your authorized BMW Motorrad retailer.

WARNING

BMW cannot examine or test each product of outside origin on the accessories and tires market to ensure that it can be used on or in connection with BMW motorcycles without constituting a safety hazard. Even approval by an official inspection authority or an official permit (General Operating Permit) cannot always provide this guarantee. Tests conducted by these instances cannot make provision for all operating conditions experienced by BMW motorcycles and consequently, they are not sufficient in some circumstances.

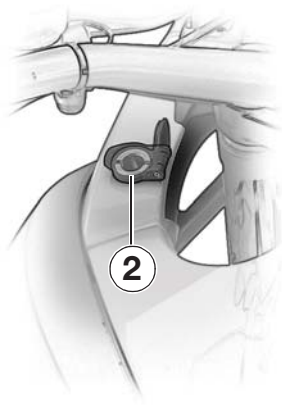

Sockets

The on-board sockets **1** and **2^{OA}** and the plug for optional accessories have a combined maximum rating of 5 A. Socket **2^{OA}** is intended solely for accessories mounted in the cockpit or secured to the handlebars, for example GPS, Roadbook, Tripmaster etc.

NOTE

The supply to the sockets is switched off automatically if battery voltage is low or the load exceeds the maximum rating.

Operating electrical accessories

NOTE

You can start using electrical accessories only when the ignition is switched on, in other words when the ignition key is in the  position. The accessory remains operational if the ignition is subsequently switched off.

Approx. 15 minutes after the ignition is switched off and/or during starting, the on-board sockets are switched off to reduce the load on the on-board electrical system.

Wiring

NOTE

Have the wiring installed by a specialized workshop, preferably an authorized BMW Motorrad retailer.

WARNING

The wiring must be installed in such a way that the cable(s)

- do not impede the rider
- do not restrict or impede movement of the handlebars and/or handling
- cannot be trapped

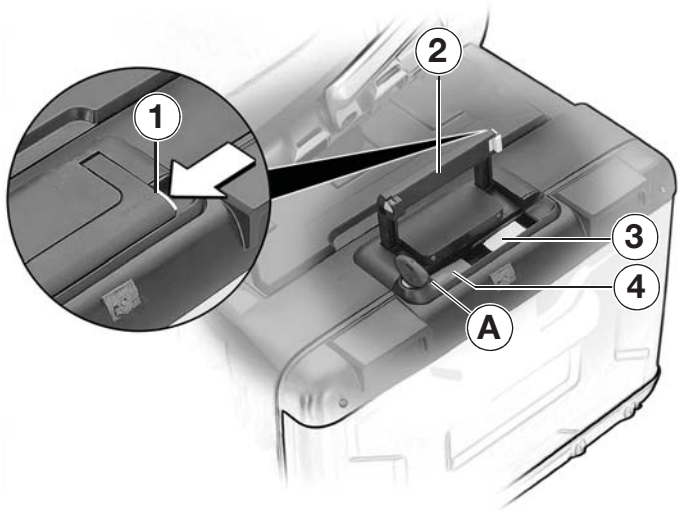

⚠ WARNING

After an accident or if the motorcycle has fallen over, check the system cases for firm seating.

**Max. load per system case:
22 lbs (10 kg).**

With system cases installed, it is advisable not to exceed 80 mph (130 km/h).

Opening system cases^{OA}

- Turn the key in the case lock to position **A**
- Release latch **1** by pressing in the direction indicated by the arrow
- Hold down latch **1** and pull up carrying handle **2**
 - Yellow rocker switch **3** and red lever **4** are accessible
- Press ribbed part of yellow rocker switch **3**
- Hold the rocker switch down and open the lid of the case

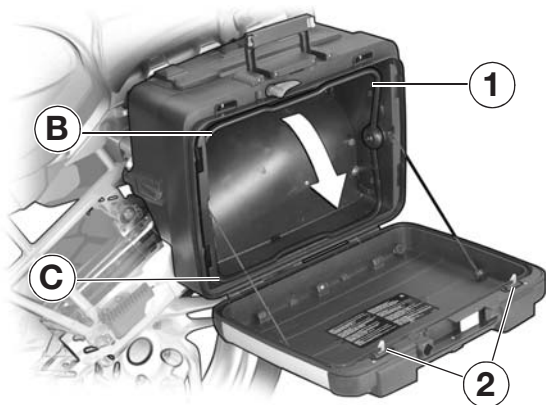

Closing system case^{OA}

⚠ CAUTION

Before closing the carrying handle, make sure that the case lock is in position **A**.
Risk of breaking the locking tongue.

- Turn the key in the case lock to position **A** (→ 97)
- Lift the lid and push it closed until the two hooks **2** at the sides engage with an audible click.
- Fold down the carrying handle
- Lock the case and remove the key

Changing case volume

📄 NOTE

Pivot lever **1** enables you to change the volume of the case.

- Open the system case
 - Take everything out of the system case
 - Turn pivot lever **1** to change the volume of the case
- Turn pivot lever **1** into end position **B**:
- Case set to low volume
- Turn pivot lever **1** into end position **C**:
- Case set to high volume

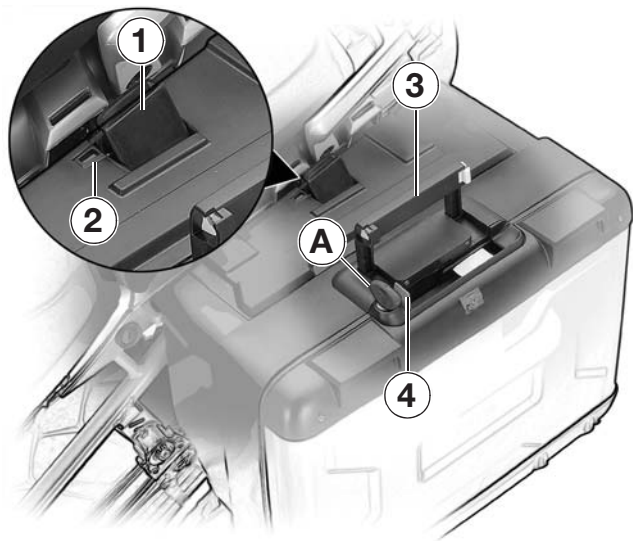

Installing system case^{OA}

⚠ WARNING

When attaching, make sure that the case is retained securely.

An incorrectly secured case could be lost and endanger other road users.

- Fold up carrying handle **3**
- Pull up red lever **4** to unlock latching flap **1**
- Pull latching flap **1** fully open
- Hold the case straight and lower it into the two top holders
- Push down latching flap **1** until window **2** turns black

Luggage system

5

98

Accessories

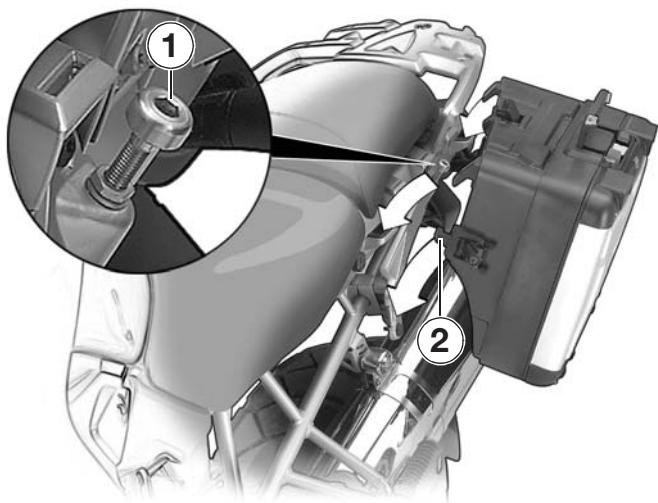

- Turn red lever **7** (➡ 99) down while pressing on the latching flap **3**
 - Latching flap **3** (➡ 99) engages
- Engage locking lever **2** in the holder and close it
- Check the security of the case
- Fold carrying handle (➡ 99) down
- Lock the case and remove the key

NOTE

Mushroom head **1** must be adjusted accordingly if the case sits loose or refuses to latch.

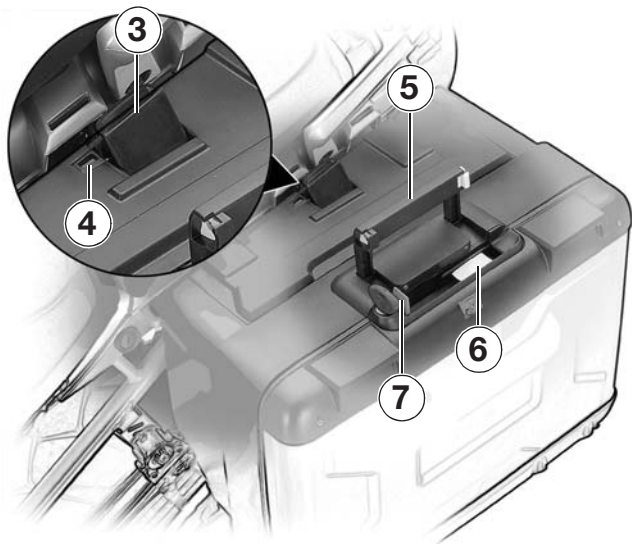

Removing system case^{OA}

- Unlatch carrying handle **5** and pull it up (→ 95)
- Yellow rocker switch **6** and red lever **7** are accessible underneath the handle
- Open locking lever **2**
- Pull up lever **7** to unlock latching flap **3**
- Pull latching flap **3** fully open
 - Window **4** turns red
- Take a firm grip of the handle and lift the case off the holder

Luggage system

5

100

Accessories

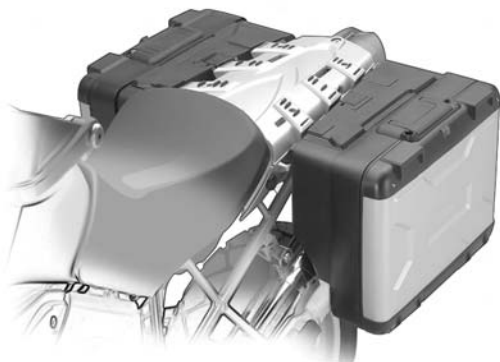

⚠ WARNING

Do not exceed the gross weight limit of the cases.

📄 NOTE

Removing the luggage rack with the passenger seat removed and the system cases^{OA} mounted results in a large-area luggage carrier with various lashing options.

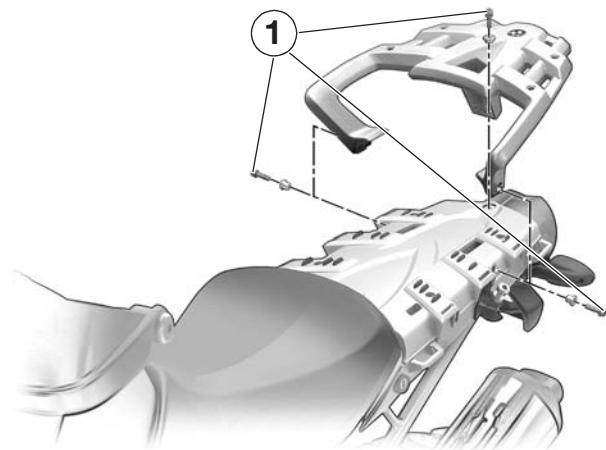

Removing luggage rack

- Remove the rear seat (➔ 46)
- Remove the system cases^{OA}
- Loosen three securing screws **1**
 - and remove complete with sleeves and washers
- Remove the luggage rack
- The procedure for installing the luggage rack is the reverse of the removal procedure
- Tighten the three mounting screws **1** with the specified tightening torque (➔ 172)

- Install the system cases^{OA}

NOTE

When installing, make sure that the spacer sleeves and washers are installed right way round.

CAUTION

Always have the tightening torques checked by a specialized workshop, preferably an authorized BMW Motorrad retailer.

Reliable operation

Service worldwide

Training means extra safety

Know-how...

Regular visits to the workshop for routine servicing are strongly recommended even after the warranty has expired. Only then can you really be sure that your BMW is in optimal condition. For generous treatment of claims submitted after the warranty period has expired, evidence of regular maintenance by an authorized BMW Motorrad retailer is essential.

Certain signs of wear, moreover, may otherwise not be noticed until it is too late to put them right at moderate cost. The staff in the authorized BMW Motorrad retailer's workshop know every detail of your motorcycle and can take remedial action if necessary before minor faults develop into serious problems. By having the necessary repairs done properly and in good time, you save time and money in the long run.

...service

You can obtain accurate advice in all cases, and make appointments with a firm completion deadline which we will comply with punctually. But the most gratifying feeling of all is that your BMW is in genuinely good shape when it leaves the authorized BMW Motorrad retailer's workshop – and above all, safe.

BMW Motorrad Service Card

A Service Card is available for all new BMW motorcycles.

A wide range of emergency-assistance services are in place to help you in the unlikely event of a problem occurring somewhere far from home.

If you have a breakdown anywhere in Europe, just call our Mobile Service Center number from any telephone. Our experts are on duty there day and night to arrange assistance for you. They can provide practical advice on what to do next and can make arrangements on your behalf, for example notifying local emergency services anywhere in Europe, recovery and transportation of the motorcycle to the nearest authorized BMW Motorrad retailer, a taxi for you, and even a replacement vehicle and hotel accommodation, if necessary.

BMW Service worldwide

And if your travels take you even further away from home, you have no need to worry: we are represented in more than 100 countries of the world.

NOTE

Call us if you have any questions about the BMW dealership network. You'll find corresponding telephone numbers in the "Service Kontakt / Service Contact" booklet.

Cornering and braking need to be practiced

Develop a “sixth sense” for potentially dangerous situations. What this means: look ahead, plan how to avoid possibly dangerous situations and study other road users' behavior with a degree of healthy skepticism.

- Take bends smoothly and rhythmically, avoiding harsh braking and acceleration
- Approach bends slower than you feel they can be taken; a neat riding style will get you to your destination more safely than sheer speed
- Ride at the inner edge of the ideal line, look ahead and plan to leave the bend as smoothly as you entered it

Allow for reaction time when judging braking distances.

- At a speed of approx. 30 mph (50 km/h), for instance, one second's hesitation means that about 46 feet (14 meters) are covered before the brakes are applied
- At approx. 55 mph (90 km/h), this distance grows to 82 feet (25 meters).

Practice applying the brakes with and without an extra load on the motorcycle, and study its reactions on various kinds of road surface.

Work up to the wheel lock limit gradually.

BMW has a worthwhile safety contribution to make in this area too – BMW Safety Training.

These programs are a wonderful opportunity: systematic basic and follow-up training enables you to master situations close to the limit and keep your motorcycle under supreme control whatever happens.

Safety information

Troubleshooting chart

Engine oil

Brake system - general

Brake system - without BMW Integral ABS

Brake system - with BMW Integral ABS^{OE}

Clutch

Wheels

Removing the front wheel

Installing the front wheel

Removing rear wheel

Installing the rear wheel

Checking brake pads

Notes on changing bulbs

Bulbs

Air filter

Jump starting

Battery maintenance instructions

Removing and installing battery

Technical modifications

WARNING

The data stored in the engine-electronics control unit is the result of extensive experimental and testing.

Tampering with the engine-electronics control unit represents an increased safety risk for the rider.

NOTE

Manipulation of the control unit of the electronic engine management system voids the warranty in all instances of damage consequential to such manipulation.

Whenever you are planning such modifications, comply with all the legal requirements.

The motorcycle must not infringe your national road-vehicle construction and use regulations.

Your authorized BMW Motorrad retailer will gladly advise you on technical requirements, the manufacturer's recommendations and the overall benefit likely to be obtained.

Troubleshooting chart

Fault: Engine does not start or is very difficult to start

Possible cause	Remedy	See ➡ Page
Kill switch operated	Move the kill switch to the run position&	(➡ 64-66)
Side stand extended and gear engaged	Fully retract the side stand	(➡ 66)
Gear engaged (clutch lever not pulled in)	Select neutral (or disengage clutch)	(➡ 67)
Clutch pulled when ignition was OFF	Switch on the ignition, then pull the clutch lever	
No fuel in tank	Refuel	(➡ 78-79)
Blocked air filter element	Replace	(➡ 140-142)
Spark plugs/leads or caps wet	Dry	
Battery not adequately charged	Recharge battery	(➡ 147)

NOTE

In case of any other faults – and additional work not described on pages 111 - 150 – please contact a specialized workshop, preferably your authorized BMW Motorrad retailer.

NOTE

You can obtain further technical information from the following publications:

- BMW Repair Manual

Checking oil level

Check the oil level at regular intervals.

Always check the oil level when the engine is at operating temperature, because the difference between the oil level indicated when the engine is at operating temperature and the oil level indicated when the engine is very cold can be as much as 0.4 in (10 mm).

After switching off the engine at operating temperature, wait at least 5 minutes for the oil to drain back into the sump.

Checking the oil level after the engine has been run only briefly or when it is not properly warm will falsify the reading and could lead to the engine being operated with the wrong quantity of oil, because cold oil is viscous and takes longer to drain back into the sump. At extremely low outdoor temperatures (14 °F/-10 °C), this can take as long as 12 hours.

CAUTION

To avoid damage to the engine:

- Never exceed the maximum oil level.
- Always keep the level above the minimum mark.

Always check the oil level with the motorcycle upright.

- Check the oil level with the engine at its regular operating temperature
- Check the oil level after the engine has been stopped for at least 5 minutes
- Make sure that the motorcycle is upright
 - Make sure the ground is level and firm.

Engine oil

7
112

Maintenance

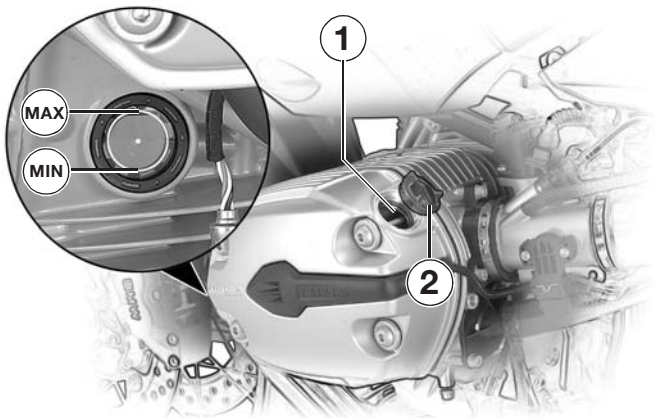

- Check the oil level at the display:
 - MAX** top edge of marking ring
 - MIN** bottom edge of marking ring
- The space between the marks represents approx. 0.53 qt (0.5 liter)
- If necessary, remove oil filler plug **2**
- Add engine oil via filler neck **1**
- Reinstall oil filler plug **2**

⚠ CAUTION

The red General warning light ⚠, in conjunction with the engine oil-pressure warning indicator  indicates no or insufficient oil pressure in the lubrication system; they must not be regarded as an oil level indicator.

Oil pressure builds up in 1-2 seconds after the engine starts, and the engine oil pressure warning  (➡ 19) must disappear and the red General warning light ⚠ (➡ 21) must go out.

BMW recommends Castrol



Brake system, checking

WARNING

Sudden changes in play or spongy action of the brake lever indicate a fault in the brake system.

Before riding off, therefore, always check the resistance of the front and rear brake levers and test operation of the brakes.

Do not ride the motorcycle if you have any doubts about the safety of the brake system.

Immediately seek the advice of a specialized workshop, preferably an authorized BMW Motorrad retailer.

Working on brake system

WARNING

To ensure reliability have all work on the brake systems performed by a specialized workshop, preferably an authorized BMW Motorrad retailer.

Checking brake pads

 WARNING

Have the brake pads replaced as soon as they wear to the minimum permissible thickness: have the work performed by a specialized workshop, preferably an authorized BMW Motorrad retailer.

Brake pad wear depends on your personal style of riding. Frequent off-roading in particular tends to accelerate the rate of brake-pad wear.

To ensure reliable operation of the brakes: have brake pads replaced before the minimum permitted thickness is reached. Checking brake pads (►► 130-131)

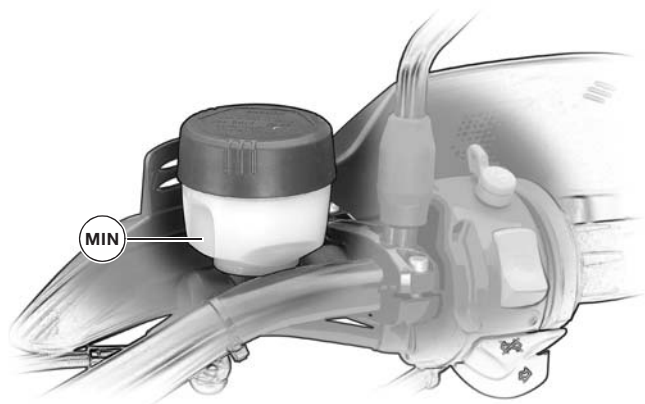

Checking front brake fluid level

WARNING

If the fluid level drops below the MIN mark, assume there is a defect in the brake system.

Have the brake system checked immediately by a specialized workshop, preferably an authorized BMW Motorrad retailer.

- Make sure that the motorcycle is upright
 - Make sure the ground is level and firm
- Handlebars centered
- Check the brake fluid level in the reservoir

MIN Minimum level

NOTE

Without BMW Integral ABS the brake fluid level in the brake fluid reservoir drops in the case of brake pad wear. With BMW Integral ABS^{OE} the brake fluid level remains constant.



Checking rear brake fluid level

⚠ WARNING

If the fluid level drops below the **MIN** mark, assume there is a defect in the brake system. Have the brake system checked immediately by a specialized workshop, preferably an authorized BMW Motorrad retailer.

- Make sure the ground is level and firm and lift the motor-cycle onto its main stand
- Check the brake fluid level in the reservoir

MIN Minimum level

📖 NOTE

Without BMW Integral ABS the brake fluid level in the brake fluid reservoir drops in the case of brake pad wear. With BMW Integral ABS^{OE} the brake fluid level remains constant.

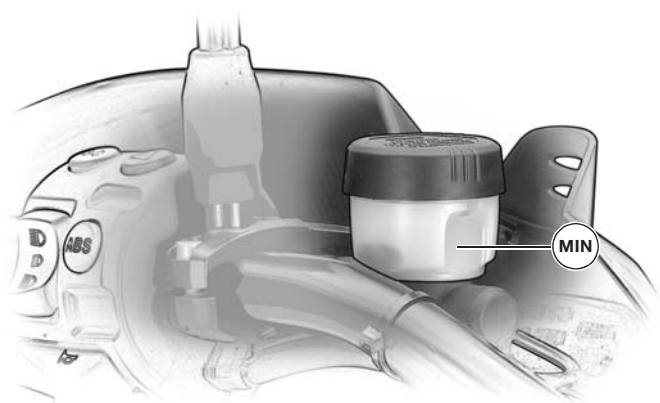

Fluid level in clutch lever fitting

The clutch system is filled with a special hydraulic fluid that does not have to be changed.

NOTE

The fluid level in the reservoir rises as the clutch wears.

CAUTION

Unsuitable hydraulic fluids could cause damage to the clutch system.

Do not top up the level in the system.

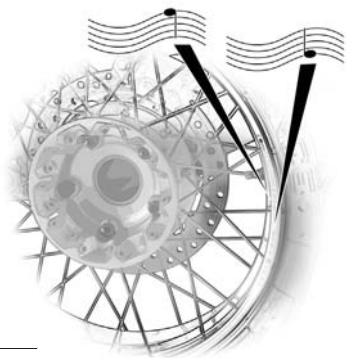

Checking wheel rims

⚠ WARNING

Have damaged wheel rims checked and, if necessary, replaced by a specialized workshop, preferably an authorized BMW Motorrad retailer.

Checking wheel spokes^{OE}

⚠ WARNING

Before every journey, check for damage to the spokes. Always have damaged spokes and irregular spoke tension rectified immediately by a specialized workshop, preferably an authorized BMW Motorrad retailer.

- Make sure the ground is level and firm and lift the motor-cycle onto its main stand
- Tap spokes with adequate device (e.g. screwdriver) and listen for the correct ringing sound

🔧 NOTE

If the note varies, spoke tension is uneven (some spokes too loose or too tight).

Checking tire tread depth

Road and massive-bar tires

⚠ WARNING

Comply with local legal requirements concerning minimum tread depth.

Remember:

Handling and grip can be impaired even before the tires wear to the minimum tire tread depth permitted by law.

- Measure tread depth at the center of the tire tread

⚠ WARNING

The maximum permissible speed for a motorcycle fitted with massive-bar tires^{OE} is 100 mph (160 km/h); do not exceed this limit.

A label stating the maximum permissible speed must be affixed in the rider's field of vision.

⚠ WARNING

Use only wheels and tires that BMW Motorrad has approved for your motorcycle. For each size of tire BMW tests certain makes, and approves those that it certifies as roadworthy.

BMW Motorrad cannot judge the suitability of unapproved wheels and tires, and is therefore unable to accept liability for the driving safety of those products.

Detailed information is available from our BMW Motorrad retailer or on the Internet at "www.bmw-motorrad.com/maintenance"

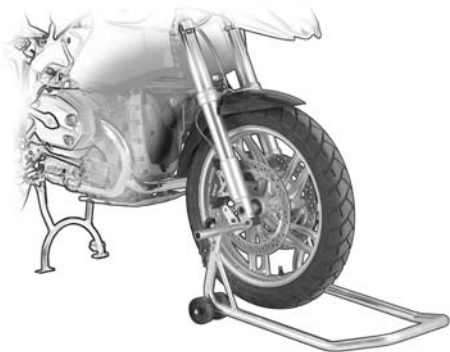

⚠ CAUTION

When removing, avoid damage to brake pipes, brake disks, brake pads and the wheel rim (mask off with tape if necessary).

Do not scratch the rim when forcing back the brake pads or removing the calipers (apply masking tape if necessary).

To prevent damage to the brake caliper and possible difficulty when assembling: never pull the brake lever when the brake calipers have been removed.

Motorcycle with BMW Integral ABS^{OE}:

Do not damage the ABS sensor cable, the ABS sensor ring and the ABS sensor.

Removing front wheel

- Make sure the ground is level and firm and lift the motorcycle onto its main stand
- front wheel with front wheel stand, BMW special tool No. 36 3 970, or a suitable auxiliary stand

🔧 NOTE

Make sure that the auxiliary stand is set to the correct width and height.

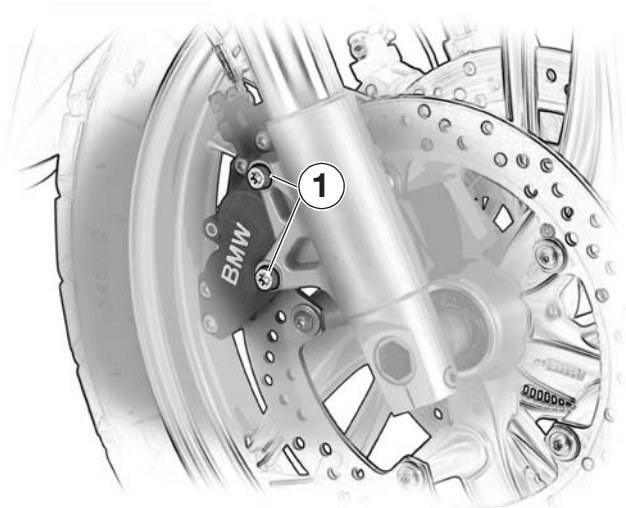

⚠ WARNING

Make sure that the motorcycle is standing firmly and cannot topple forward or to either side.

- Remove securing screws **1** for the left and right brake calipers
- Push the brake pads back a little by lightly rocking the brake calipers
- Carefully take off the left and right brake calipers

🔧 NOTE

(👉 130) Check the brake pads and have them replaced if necessary.

Wheels

7

122

Maintenance

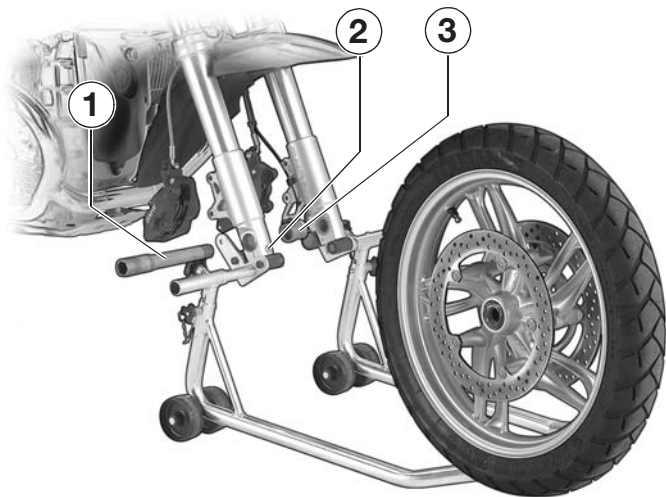

- Loosen axle clamping screw **2**
- Remove quick-release axle **1**
- Roll the front wheel forward and out
- Remove spacing bushing **3** from the wheel hub

⚠ CAUTION

When setting down the front wheel, do not damage the brake disks and ABS sensor ring^{OE}. Keep dirt and moisture away from the wheel bearings.

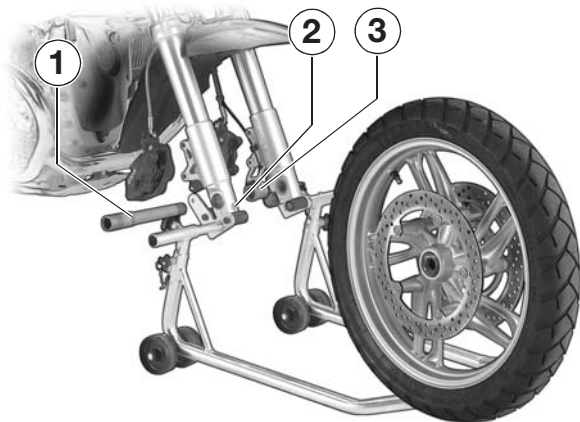

Installing front wheel

CAUTION

Do not damage brake lines, disks and pads when installing. Keep dirt and moisture away from the wheel bearings. Motorcycle with BMW Integral ABS^{OE}: Do not damage the ABS sensor cable, the ABS sensor ring and the ABS sensor.

NOTE

Note arrow on tire indicating correct direction of rotation.

WARNING

Make sure that the motorcycle is standing firmly and cannot topple forward or to either side.

- On left as viewed in forward direction of travel:
 - Insert spacing bushing **3** into the wheel hub
 - Roll the front wheel in between the fork stanchions
 - Clean quick-release axle **1**, lubricate and screw in hand-tight from the right while lifting the wheel
 - Hand-tighten axle clamping screw **2**

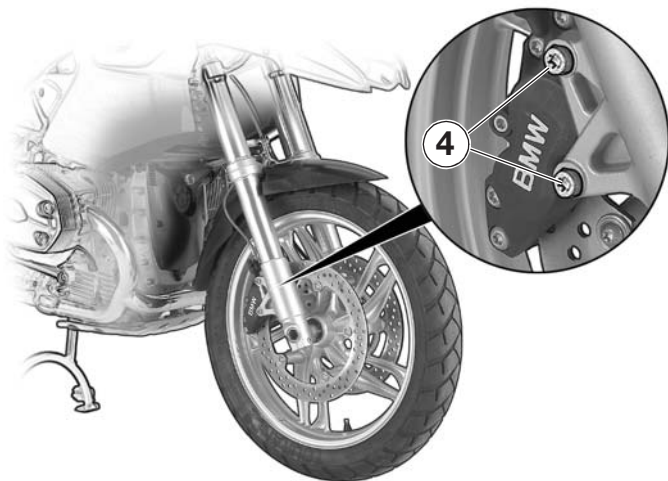

⚠ WARNING

Motorcycle not equipped with BMW Integral ABS: once assembly work on the brake calipers has been completed, pull the handbrake lever firmly several times.

Motorcycle equipped with BMW Integral ABS^{OE}: once assembly work on the brake calipers has been completed, pull the handbrake lever after the ignition has been switched on and self-diagnosis has completed.

- Remove front-wheel stand
- Compress the front forks firmly several times
- Tighten axle **1** to the specified tightening torque (► 172)
- Tighten axle clamping screws **2** (► 172) to the specified tightening torque
- Carefully slip the brake calipers over the left and right brake disks
- Install the brake calipers and tighten screws **4** to the specified tightening torque (► 172)

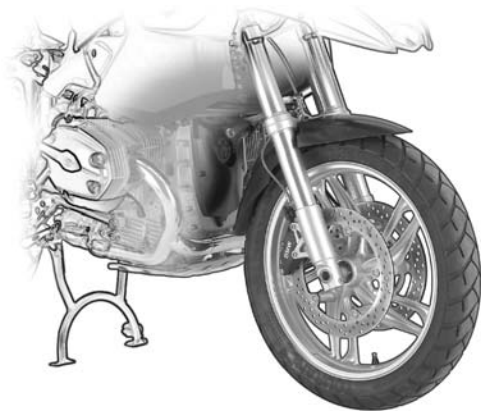

Installing front wheel

Without BMW Integral ABS

- Firmly pull the handbrake lever several times

With BMW Integral ABS^{OE}

- Switch on the ignition
- Wait for self-diagnosis to complete
- Pull the handbrake lever

CAUTION

Always have the tightening torques checked by a specialized workshop, preferably an authorized BMW Motorrad retailer.

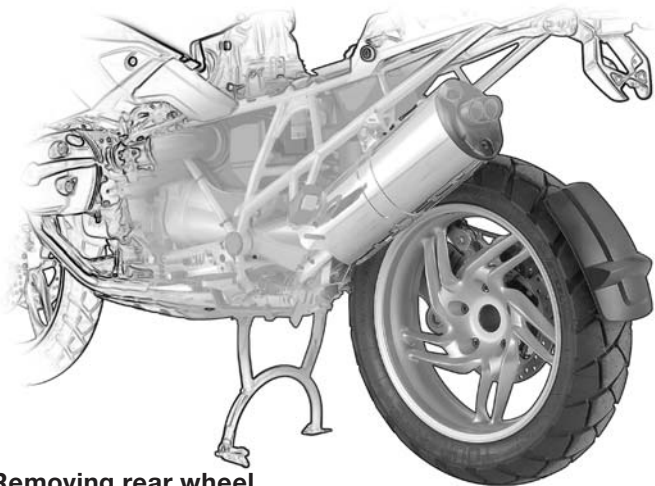

Removing rear wheel

NOTE

Check the brake pads (➔ 131) and have them replaced if necessary.

- Make sure the ground is level and firm and lift the motorcycle onto its main stand

WARNING

Make sure that the motorcycle is standing firmly and cannot topple backwards or to either side.

CAUTION

Do not damage brake lines, brake disk, brake pads, rims and spokes when removing. Motorcycle with BMW Integral ABS^{OE}: Do not damage the ABS sensor cable, the ABS sensor ring and the ABS sensor.

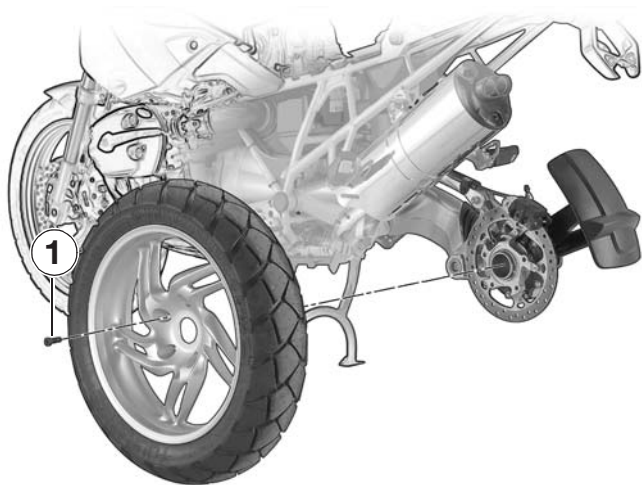

- Apply a weight to the front wheel
- Select 1st gear
- Unscrew five wheel studs **1**
- Lift the rear wheel clear of its centering spigot, tilt it, lower it to the ground and remove it

CAUTION

Protect the wheel hub contact face against dust and dirt.

Installing rear wheel

WARNING

The length code numbers of the wheel studs of the cross-spoked wheel^{OE} and of the cast aluminum wheel differ. Be sure not to mix up the wheel studs or use a mixture of the two lengths.

CAUTION

Use only wheel studs with the same length code number. Do not oil or grease the wheel studs.

Do not damage brake lines, brake disk, brake pads, rim and spokes when installing.

Motorcycle with

BMW Integral ABS^{OE}:

Do not damage the ABS sensor cable, the ABS sensor ring and the ABS sensor.

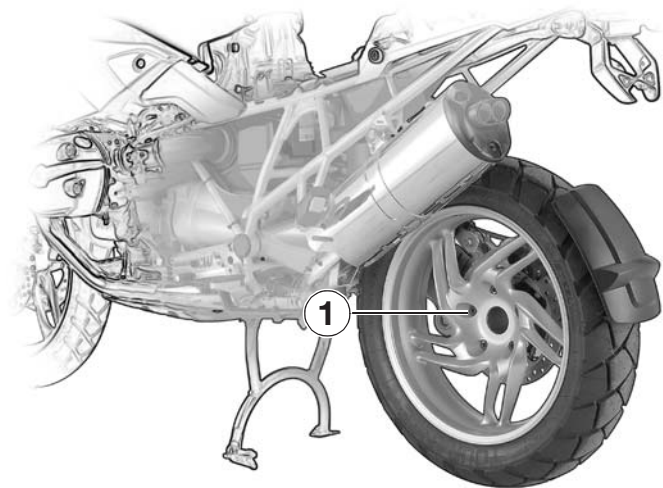

- Check that the wheel centering spigot and the contact faces on the wheel hub are free of grease
- Insert rear wheel into centering hole
- Hand-tighten wheel studs **1** and then tighten in diagonally opposite sequence to preload torque (► 172)

CAUTION

Always have the tightening torques checked by a specialized workshop, preferably an authorized BMW Motorrad retailer.

Brake pads

7
130

Maintenance

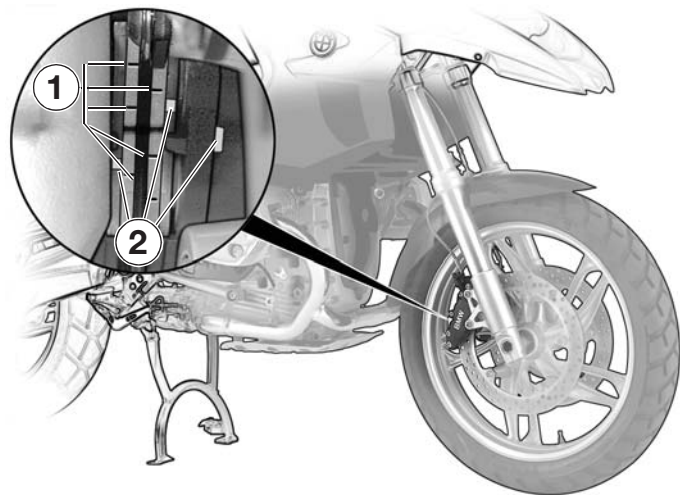

Checking front wheel brake

⚠ CAUTION

Have brake pads replaced before the minimum permitted thickness is reached.

- Make sure the ground is level and firm and lift the motorcycle onto its main stand
 - Visually inspect both sets of brake pads and brake calipers and make sure that they all bear the same color mark **2**
 - Visually check brake pad thickness
- Minimum pad thickness: Wear indicator 1 must be clearly visible on the pads.**
- If the wear indicator is no longer clearly visible: **have the brake pads replaced by a specialized workshop, preferably an authorized BMW Motorrad retailer.**

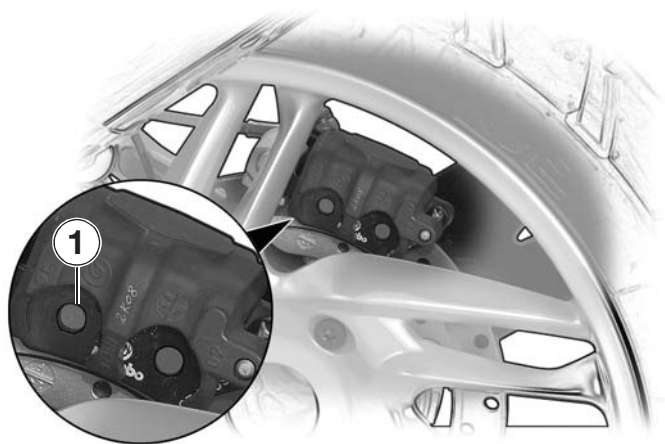

Checking rear wheel brake

CAUTION

Have brake pads replaced before the minimum permitted thickness is reached.

- Make sure the ground is level and firm and lift the motorcycle onto its main stand

- Visually check brake pad thickness

Minimum pad thickness:

Make sure that the brake disk is not visible through bore 1 in the inboard brake pad.

- If the brake disk is visible through bore **1** in the inboard brake pad:

have the brake pads replaced by a specialized workshop, preferably an authorized BMW Motorrad retailer.



⚠ WARNING

When the engine is running or the ignition is switched on, do not touch electrically live components, terminals or wiring.

Risk of fatal accident.

Work on the electrical system only when the circuit has been interrupted (ignition switched off). For greater safety, disconnect and insulate the negative battery lead.

Your motorcycle has one bulb for the low-beam headlight and one for the high-beam headlight, one for the parking light, one for the brake light and one for the rear light, plus four bulbs for the turn indicators.

A bulb failure is indicated by  in the multifunction display, in some instances in combination with the General warning light  (➔ 19-22).

⚠ WARNING

A bulb failure can mean that you will have problems in seeing and being seen.

You should therefore always carry spare bulbs on the motorcycle.

 NOTE

Do not touch the glass of new bulbs with your fingers. Use a clean, dry cloth to hold the bulbs when inserting them. Dirt deposits, in particular oil and grease, interfere with heat radiation from the bulb. This leads to overheating and shortens the bulb's operating life.

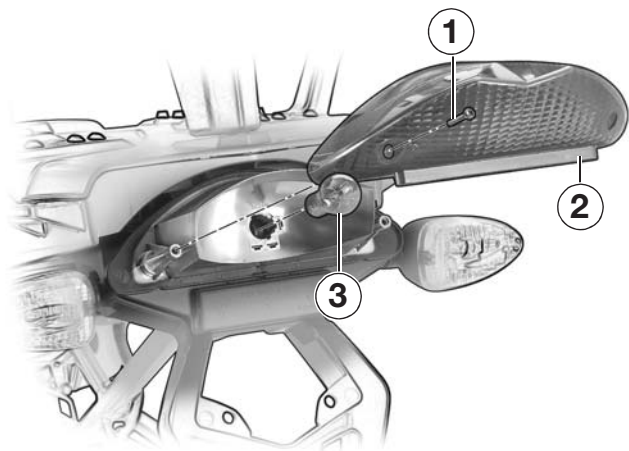

Replacing brake/rear light bulb

CAUTION

Switch off the ignition before changing a bulb.
Risk of short-circuit

- Remove securing screws **1**
 - Remove rear light glass **2**
 - Press bulb **3** into its socket and disengage it by turning it counter-clockwise
 - Remove bulb **3**
 - Installation is the reverse of the removal procedure
- Brake/rear light bulb **3**:
12 V 21/5 W
- Make sure the ground is level and firm and lift the motorcycle onto its main stand

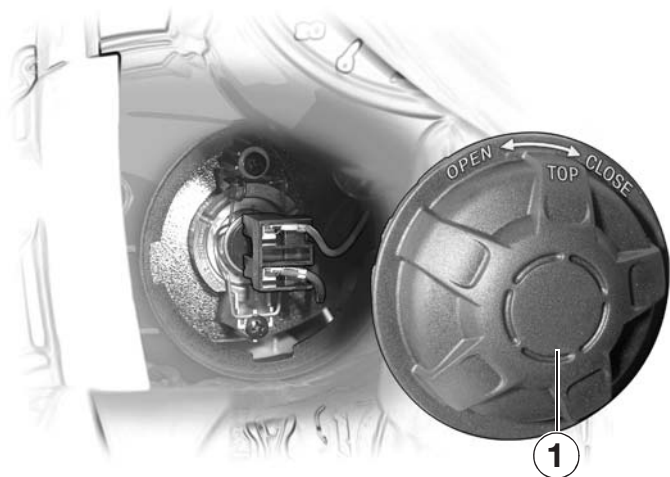

Replacing high-beam headlight bulb

⚠ WARNING

H7 bulbs are pressurized. Wear goggles and protective gloves, risk of injury.

⚠ CAUTION

Switch off the ignition before changing a bulb.
Risk of short-circuit

- Make sure the ground is level and firm and lift the motorcycle onto its main stand
- Turn the handlebars all the way to the right
- Turn left cover **1** counter-clockwise (arrow) to disengage it and remove

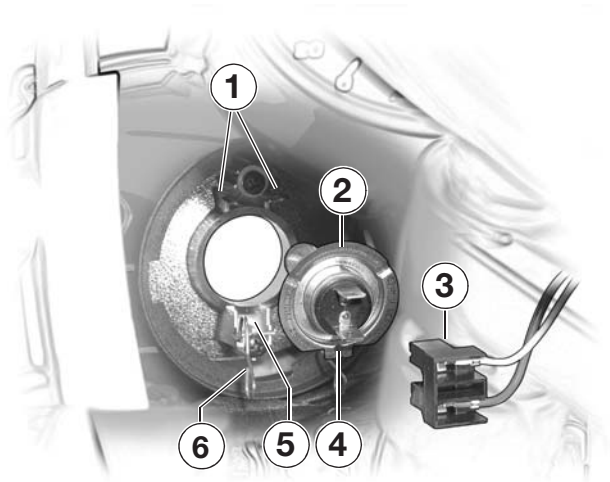

- Disconnect plug **3** from H7 bulb **2**
- Release spring clip **6** from retainers **1** on left and right and swing the clip open
- Pull H7 bulb **2** out of its bulb socket
- Installation is the reverse of the removal procedure

NOTE

Insert H7 bulb **2** with lug **4** in guide **5**.

Make sure that wording **TOP** on the cover (➡ 134) is toward the top.

– High-beam headlight **2**:
H7 12 V 55 W

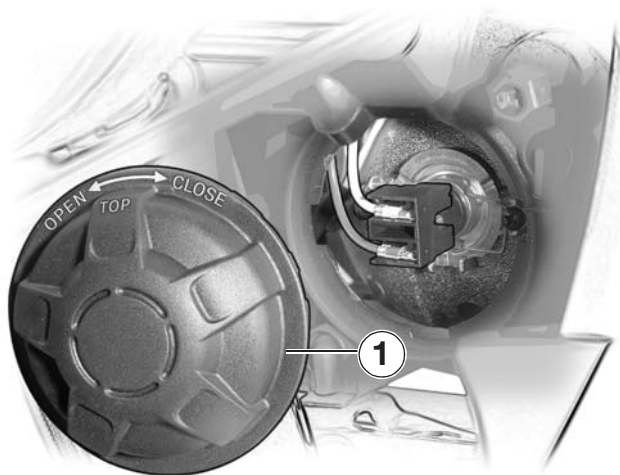

Replacing low-beam headlight bulb

⚠ WARNING

H7 bulbs are pressurized. Wear goggles and protective gloves, risk of injury.

⚠ CAUTION

Switch off the ignition before changing a bulb.
Risk of short-circuit

- Make sure the ground is level and firm and lift the motorcycle onto its main stand
- Turn the handlebars all the way to the left.
- Turn right cover **1** counter-clockwise (arrow) to disengage it and remove

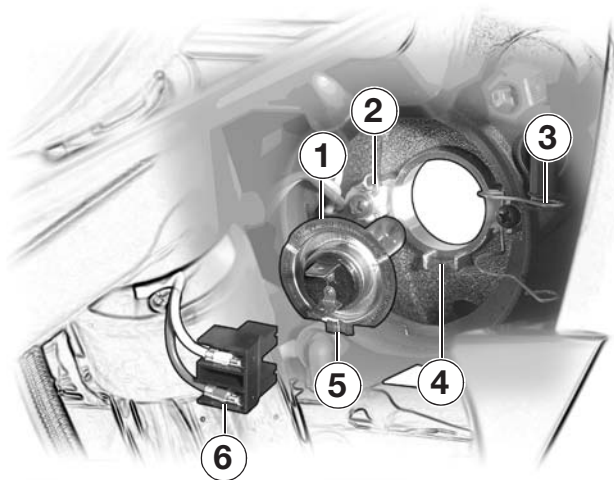

- Disconnect plug **6** from H7 bulb **1**
- Release spring clip **3** from retainers **2** at top and bottom and swing the clip open
- Pull H7 bulb **1** out of its bulb socket
- Installation is the reverse of the removal procedure

NOTE

Insert H7 bulb **1** with lug **5** in guide **4**.

Make sure that wording **TOP** on the cover (➡ 136) is toward the top.

– Low-beam headlight **1**:
H7 12 V 55 W

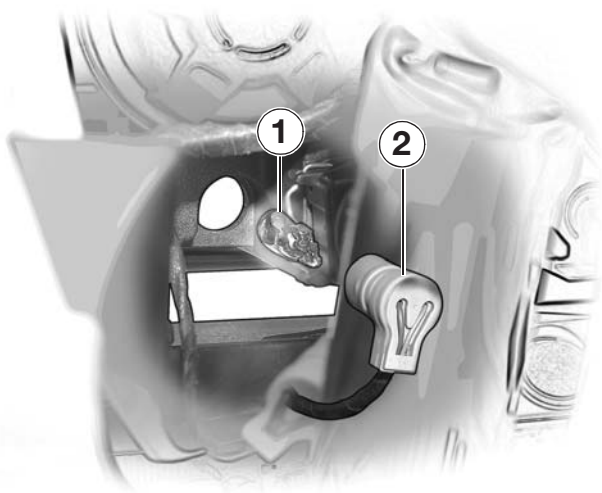

Replacing parking-light bulb

⚠ CAUTION

Switch off the ignition before changing a bulb.
Risk of short-circuit

- Make sure the ground is level and firm and lift the motorcycle onto its main stand
- Turn the handlebars all the way to the right
- Pull bulb holder **2** out of the headlight housing
- Pull bulb **1** out of its bulb socket
- Installation is the reverse of the removal procedure
- Parking-light bulb **1**: **12 V 5 W**

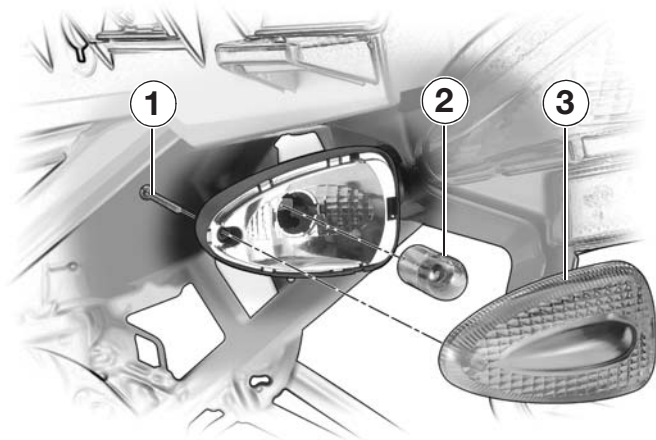

Replacing front/rear turn indicator bulbs

CAUTION

Switch off the ignition before changing a bulb.
Risk of short-circuit

- Make sure the ground is level and firm and lift the motorcycle onto its main stand
- Remove securing screw **1**
- Remove flashing turn indicator glass **3**
- Press bulb **2** into its socket and disengage it by turning it counter-clockwise
- Remove the bulb
- Installation is the reverse of the removal procedure
- Turn indicator bulbs, front/rear **2: 12 V 10 W**

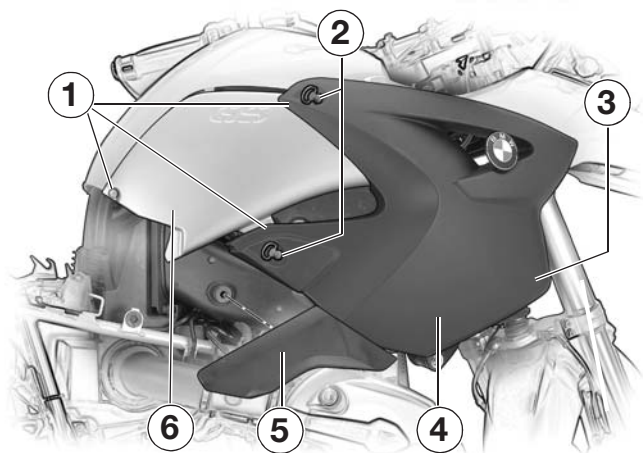

Replacing air filter element

- Make sure the ground is level and firm and lift the motorcycle onto its main stand
- Remove the front and rear seats (➡ 46)
- Remove the right side panel as follows:
- Pull cover **5** out of its holders
- Turn two quick-action adapters **2** counter-clockwise to unlatch
- Working from inside, turn quick-release adapter **3** counter-clockwise to unlatch
- Pull front trim piece **4** upward at front (marking) out of holders and remove
- Remove three securing screws **1** and rear panel **6**

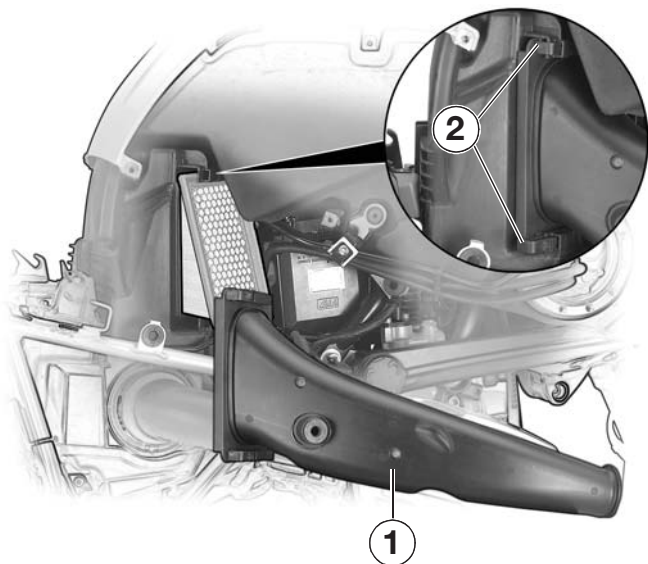

- Unlock two retaining clips **2** by pressing the rear end and pull out
- Remove intake **1**

CAUTION

Make sure that the throttle-valve cable is not disengaged when you remove the air filter element.

- Pull out the old air filter element downward and toward the front as shown

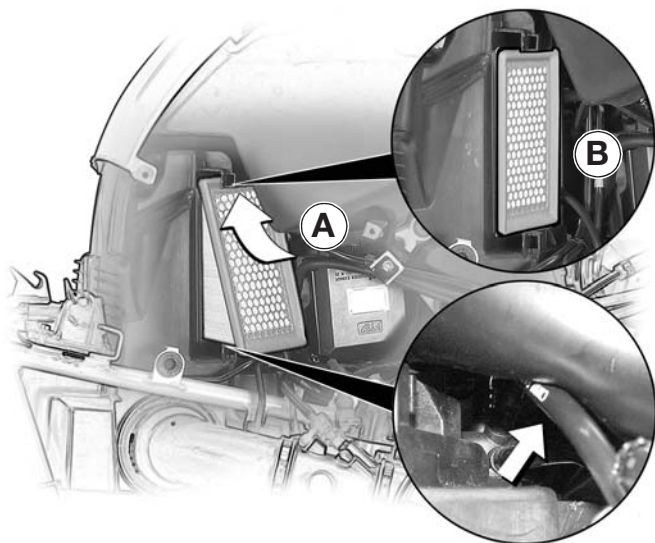

- As shown in the illustration, first insert the new air filter element from above into the air filter housing **A**
- and then press into the air filter housing at the bottom **B**
- From this point on, installation is the reverse of the removal procedure

NOTE

This procedure for removing and installing the air filter element prevents dirt from entering the air filter housing.

CAUTION

After installing, check that both throttle valves move to their limit stops.

Make sure that the throttle-valve cable (arrow) is correctly routed.

Jump starting

CAUTION

Do not attempt to jump-start the motorcycle using the on-board socket.

Risk of fire

The wires leading to the power socket do not have a load-capacity rating adequate for jump-starting the engine.

CAUTION

If you switch on the ignition and the indicator lights fail to light up, the battery is completely flat. In this case, do not attempt to jump-start the motorcycle: recharge the battery instead. Risk of damaging the control units.

NOTE

Do not use proprietary start-assist sprays or other products to start the engine. If the motorcycle's battery charge level is low, you can start the engine of your motorcycle with the aid of another vehicle's 12 V battery and two jump leads. By the same token, you can jump start another motorcycle. Use only jump leads fitted with fully insulated crocodile clips at both ends.

Jump starting

7

144

Maintenance

- When jump-starting the engine, do not disconnect the battery from the on-board electrical system

WARNING

Do not touch live components of the ignition system while the engine is running – Risk of fatal accident.

NOTE

Use the battery adapter point on the positive terminal on your motorcycle and the shock-absorber bolt as a ground connection for connecting the jumper cables.

CAUTION

Make sure that the battery of the other vehicle has a voltage rating of 12 V.

CAUTION

Make sure that there is no contact between the body parts of the two vehicles. Risk of short-circuit.

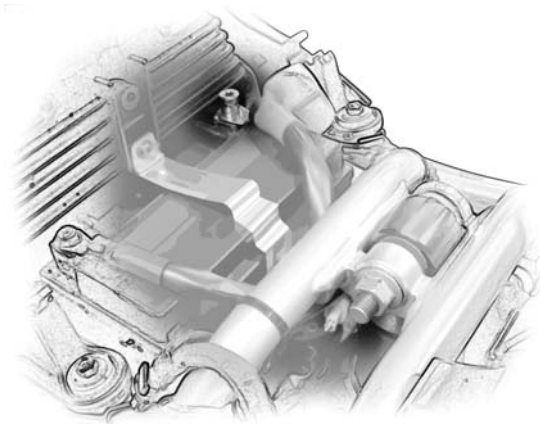

- Remove the protective cap from the battery adapter point
- Begin by connecting one end of the red jump lead to the positive terminal of the discharged battery and the other end to the positive terminal of the donor battery
- Then connect one end of the black jump lead to the negative terminal of the donor battery, and the other end to the negative terminal of the discharged battery
- Start the engine of the donor vehicle and allow it to run for the duration of the jump-start procedure
- Start the engine of the vehicle with the discharged battery in the usual way; if the engine refuses to start wait a few minutes before repeating the attempt
- Allow both engines to idle for a few minutes before disconnecting the jump leads
- Disconnect the jump lead from the negative terminals first, then disconnect the second cable from the positive terminals.
- Remember to reinstall the protective cap on the adapter point

Your motorcycle is supplied with a maintenance-free battery.

▲ CAUTION

Compliance with the points below is important in order to maximize battery life:

- Keep the surface of the battery clean and dry
- Do not attempt to open the battery
- Do not attempt to top up the battery with water
- Be sure to read and comply with the instructions for charging the battery on the next pages
- Do not turn the battery upside down.

Correct upkeep, recharging and storage will prolong the life of the battery and are essential if warranty claims are to be considered.

Charging connected battery

During longer interruptions in driving, the battery must be recharged regularly every four weeks.

▲ CAUTION

If the battery is not disconnected, the on-board electronics (clock, etc.) will drain the battery. This can cause the battery to run flat. If this happens, warranty claims will not be accepted.

It is advisable to disconnect the battery if the motorcycle is going to be off the road for a lengthy period.

If the battery is completely flat it must always be recharged directly at the terminals. In order to recharge the battery in this way, it is essential to disconnect it from the on-board electrical systems.

NOTE

BMW Motorrad has developed a trickle-charger specially designed for compatibility with the electronics of your motorcycle. Using this charger, you can keep the battery charged during long periods of disuse, without having to disconnect the battery from the motorcycle's on-board systems. Your authorized BMW Motorrad retailer will be happy to provide you with more information.

You can charge a battery that is not completely flat via the on-board socket. To do so:

- Disconnect electrical accessories, if any, connected to the second on-board socket
- Switch on the ignition
- Plug in the charger
- Switch off the ignition

NOTE

The motorcycle's on-board electronics know when the battery is fully charged. In this case the on-board socket is deenergized. If you are unable to charge the battery via the on-board socket, then the charger used may not be matched to the electronics of your motorcycle. In this case, please charge the battery directly at the terminals.

CAUTION

Remember that you must disconnect the battery from the on-board systems if you want to connect your charger directly to the battery terminals.

Charging disconnected battery

- Charge the battery, using a suitable charger
- Once the battery is fully charged, disconnect the charger's crocodile clips from the battery terminals
- If the battery is in storage for an extended period of time, recharge it at regular intervals of approx. 4 months.
- Always fully recharge the battery before returning it to use

In case of doubt ask a specialized workshop, preferably an authorized BMW Motorrad retailer, to prepare the vehicle for storing and to undertake the necessary battery maintenance and storage

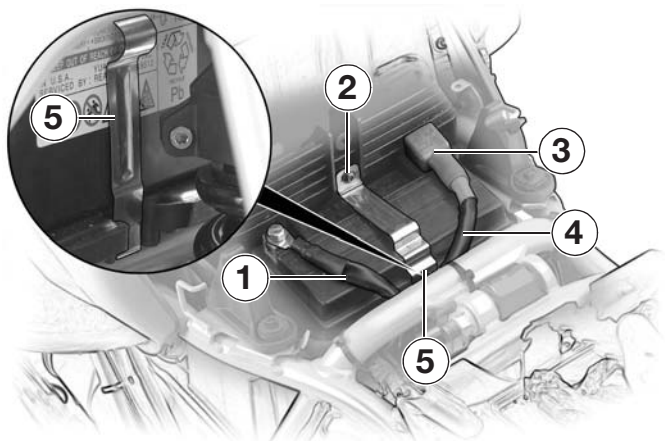

Removing battery

⚠ WARNING

Before disconnecting the battery, switch off the ignition.

To do so, turn the ignition switch to position **I, and make sure the steering lock is engaged.**

To avoid short-circuits:

- First disconnect the **negative** battery lead (-),
- then disconnect the **positive** battery lead (+).
- Remove the front and rear seats (➡ 46)
- Disconnect **negative** battery lead **1**
- Open protective cap for the battery's positive terminal **3**
- Disconnect **positive** battery lead **4**
- Remove securing screw **2** from retaining strap **5**
- Unhook retaining strap **5** at bottom and remove, see magnifying glass
- Lift out the battery

- Make sure the ground is level and firm and lift the motorcycle onto its main stand

Installing battery

7
150

Maintenance

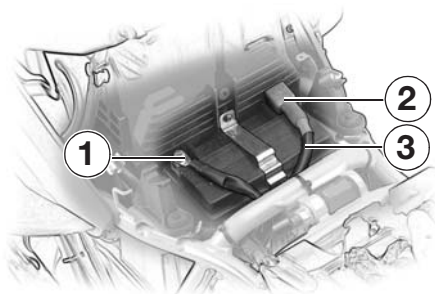

Installing battery

Installation of the battery is the reverse of the removal procedure.

⚠ WARNING

Before connecting the battery, make sure the ignition is switched off.

To do so, turn the ignition switch to position , and make sure the steering lock is engaged.

To avoid short-circuits:

- **Connect the positive battery lead (+) 3 first**
- **Close protective cap 2 for the positive battery post**
- **Never install the battery without the protective cap**
- **Connect negative battery lead (-) 1**

- Tighten battery-terminal clamps
- Switch on the ignition
- Fully open the throttle once or twice
- The engine's control unit registers the throttle-valve positions

NOTE

Remember to reset the clock after reconnecting the battery.

Washing the motorcycle

Removing road salt

Cleaning the windshield

Cleaning/care

Touching up minor damage

Care of muffler system

Cleaning/care

Storing

Returning to use

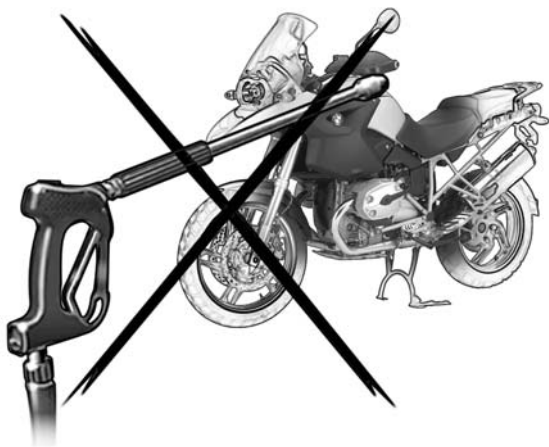

⚠ CAUTION

Do not use aggressive or penetrating cleaning agents or solvents, as they would cause damage to rubber and plastic parts.

Use only solvent-free cleaning agents to clean the seat.

Do not use a steam jet or high-pressure cleaning equipment. High water pressure can damage seals, the hydraulic brake system or the complete electrical system.

📖 NOTE

Regular cleaning, using the correct methods, is an important factor in maintaining the value of your motorcycle.

It also ensures that safety-relevant parts remain in full working order.



Washing motorcycle

⚠ WARNING

After cleaning and before starting a journey, always test the brakes.

- Make sure the ground is level and firm and lift the motorcycle onto its main stand
- Apply a mild cleaning agent to the wheels, engine block, transmission and swinging arm, in accordance with the manufacturer's instructions
- Thoroughly dry all wet surfaces
- Do not use solvents or cleaning agents to clean the instrument panel, switches and windshield – take care not to scratch the windshield
- Remove tar splashes only with an approved product – rinse thoroughly with water afterwards.
- Clean flies and other insects off the fork stanchions
- Treat painted and chrome-plated surfaces regularly with the approved care products



Removing road salt

- Wash the motorcycle down immediately with cold water at the end of the journey.

NOTE

Do not use warm water – this aggravates the effect of the salt.

- Thoroughly dry the motorcycle
- Apply a wax-based corrosion-proofing product to chrome-plated parts
- Coat/polish fairing elements after cleaning and drying with a recommended wax

Cleaning windshield

CAUTION

Do not use cleaning agents. Fuel or chemical solvents attack the windshield material.

- Remove dirt and dead insects with a soft sponge and plenty of water

NOTE

Soften stubborn dirt or insects by soaking with a wet paper towel.

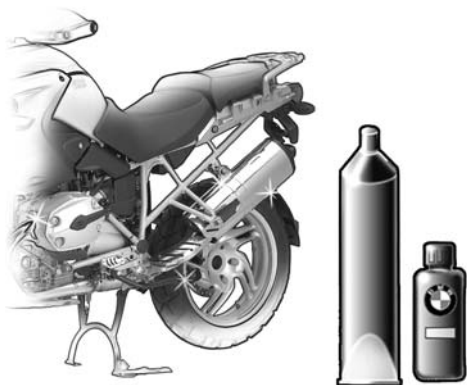

Touching up minor damage

CAUTION

Comply with the manufacturer's working instructions and safety precautions.

- Minor damage caused by stones striking the painted surface can be touched up with a BMW touch-up pencil of the correct color

NOTE

Have severe damage repaired by a specialized workshop, preferably your authorized BMW Motorrad retailer.

Care of muffler system

- Changes in the appearance of the mufflers during operation or as a result of environmental influences can be treated with a polish available from your authorized BMW Motorrad retailer.



Storing

- Clean the motorcycle (➡ 153)
- Remove the battery (➡ 149-150)
- Spray the brake and clutch lever pivots and the main and side stand pivots with a suitable lubricant
- Coat bright metal/chrome-plated parts with an acid-free grease (e.g. Vaseline)
- Place the motorcycle on its main stand in a dry room
- Support the motorcycle under the engine so that the wheels are not taking any weight

NOTE

Before laying the vehicle up out of use have the engine oil and the oil filter element changed by a specialized workshop, preferably your authorized BMW Motorrad retailer.

It is always a good idea to combine the preparations for storage and post-storage work with a Service check or Inspection conducted by a specialized workshop, preferably your authorized BMW Motorrad retailer.



Returning to use

- If necessary, remove protective wax coating
- Clean the motorcycle (➡ 153)
- Install a charged battery (➡ 149-150)
- Perform all safety checks (➡ 60)
- Check brakes (➡ 80-88), (➡ 113-116) and (➡ 130-131)
- Check/correct tire pressures (➡ 53)

Engine

Power train

Frame and suspension

Fuel and lubricants

Electrical system

Dimensions and weights

Performance data

Tightening torques

Engine

R 1200 GS

Type Two-cylinder, four-stroke EVO
opposed-twin engine

Displacement 1,170 cc

Max. output to DIN 70 020

74 kW

- at engine speed 7,000 rpm

Max. torque 115 Nm

- at engine speed 5,500 rpm

Permissible engine speeds

Engine speed, maximum 7,800 rpm

Idle speed 1,150^{±50} rpm

Bore/stroke 4/2.9 in (101/73 mm)

Compression ratio 11.0 : 1

Fuel consumption to ISO 7118

constant approx. 55 mph 55 mpg
(90 km/h) (4.3 l/100 km)

constant approx. 75 mph 43 mpg
(120 km/h) (5.5 l/100 km)

Maximum oil consumption 1.7 qt / 1,000 miles
(1 l/1,000 km)

R 1200 GS

Clutch

Single-plate dry clutch

Clutch plate dia.

7 in (180 mm)

Transmission

6-speed with claw shift and integral torsional vibration damper

Gear ratios

1st gear = 4.15

2nd gear = 2.89

3rd gear = 2.30

4th gear = 1.88

5th gear = 1.65

6th gear = 1.47

Transmission from transmission to rear wheel drive

Universal shaft with integrated torsional damper

Rear wheel drive

Bevel gears

Final drive ratio

1 : 2.82

Frame and suspension

9

162

Technical data

R 1200 GS

Frame

Three-part frame concept with load-bearing engine. Tubular steel front and rear frames.

Location of type plate

Under left-hand side cover

Location of vehicle identification number (VIN)

On front frame at right

Front brake

Two floating brake disks with 4-piston fixed calipers

Sintered metal brake-pad linings

Rear brake

One fixed brake disk with 2-piston floating caliper

Organic brake pads

Frame and suspension

R 1200 GS

Wheel location

Front	BMW Telelever
Rear	BMW-EVO Paralever swinging arm
Steering lock angle	2 x 42°

Frame and suspension

R 1200 GS

Front suspension system Central spring strut with twin-tube shock absorber, spring preload adjustable in nine stages

Spring travel (bump) 4.8 in (122 mm)

Spring travel (rebound) 2.7 in (68 mm)

Total suspension travel 7.5 in (190 mm)

Fixed tube diameter 1.6 in (41 mm)

Front wheel castor in normal-load position 4.3 in (110 mm)

Rear suspension system Central spring strut with single-tube shock absorber with progressive damping. Spring preload and rebound damping steplessly variable

Spring travel (bump) 5.3 in (135 mm)

Spring travel (rebound) 2.6 in (65 mm)

Total suspension travel (at wheel) 7.9 in (200 mm)

Swinging arm length 21 in (535 mm)

Frame and suspension

R 1200 GS

Wheels and tires



You can obtain detailed information on approved tire sizes and makes from your authorized BMW motorcycle retailer or by visiting "www.bmw-motorrad.com/maintenance"

Front wheel

Angled rim shoulder and double tire retaining hump

Rim size

2.50 x 19"

Tire size

110/80-19

Rear wheel

Angled rim shoulder and double tire retaining hump

Rim size

4.00 x 17"

Tire size

150/70-17

Frame and suspension

R 1200 GS

Tire pressures (with tires cold)

One-up	Front	31.9 psi (2.20 bar)
	Rear	36.3 psi (2.50 bar)
Two-up	Front	36.3 psi (2.50 bar)
	Rear	42 psi (2.90 bar)
Two-up and luggage		
	Front	36.3 psi (2.50 bar)
	Rear	42 psi (2.90 bar)

Recommended minimum tire tread depth

Comply with local legal requirements concerning minimum tread depth.



Handling and grip can be impaired even before the tires wear to the minimum tire tread depth permitted by law.

Engine oil

Brand-name HD oil of API classification SF, SG or SH; CD or CE amendments are permissible; or brand-name HD oil of CCMC classification G4 or G5; amendment PD2 is permissible.

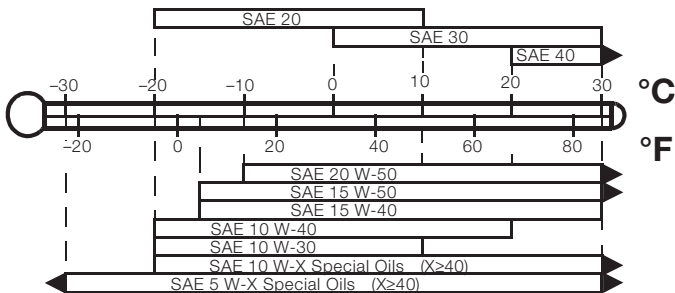

The viscosity class depends on outside temperatures. Temperatures above or below the limits quoted for the individual SAE classifications are permitted for brief periods only.

All engine oils supplied by BMW are subject to regular BMW quality assurance checks.

BMW does not approve the use of any upper-cylinder lubricants or similar oil additives.

Engine oil capacity

With filter change 4.2 qt (3.95 l)

Fuel and lubricants

R 1200 GS

Gear oils

Transmission

Castrol SAF XO

Capacity

approx. 0.85 qt (0.8 l)
(to bottom edge of filler neck)

Fuel grade

**Super (premium) unleaded fuel to
DIN 51 607 standard, minimum
octane number 95 (RON) (AKI 90)**

Fuel tank capacity (usable)

5.3 gal (20 l)
including approx. 1 gal (4 l) reserve

Brake fluid

DOT 4
We recommend BMW brake fluids

CAUTION

Use only new brake fluid to DOT 4 specification.

NOTE

Oil in fork tubes and in rear wheel drive:

Lifetime filling

Electrical system

R 1200 GS

Battery 12 V 14 Ah, maintenance-free

Low temperature test current 100 A

Spark plugs

Approved types

Primary spark plug BOSCH YR5LDE

Secondary spark plug BOSCH YR5LDE

Electrode gap 0.031 in (0.8 mm)

Wear limit 0.039 in (1.0 mm)

Fuses

All circuits are electronically protected, so plug-in fuses are no longer necessary. If a circuit has been switched off by an electronic fuse and the triggering fault has been rectified, then the circuit is active again after the ignition is switched on.

Headlights

Dual halogen headlights

Bulbs

High-beam headlight H7 halogen bulb 12 V 55 W

Low-beam headlight (riding light) H7 halogen bulb 12 V 55 W

Parking light DIN 72 601 12 V 5 W
Standard designation T 8/4

Brake light/tail light DIN 72 601 12 V 21/5 W
Standard designation P 25-2

Flashing turn indicators DIN 72 601 12 V 10 W
Standard designation P 25-1

Power socket

12 V 5 A for connecting GPS, Roadbook, Tripmaster etc.

Dimensions and weights

R 1200 GS

Maximum length	87 in (2,210 mm)
Maximum width (without mirrors)	36 in (915 mm)
Maximum height (without rider)	56.3 in (1,430 mm)
Seat height	33.1/33.9 in (840/860 mm)
Wheelbase	
- in normal-load position	59.8 in (1,520 mm)
Ground clearance	
- in normal-load position	7.4 in (187 mm)
DIN unladen weight	496 lbs (225 kg)
Dry weight (according to EU specification)	465 lbs (211 kg)
Permitted gross weight	937 lbs (425 kg)
Maximum payload	441 lbs (200 kg)
Permissible wheel loads	
Front	375 lbs (170 kg)
Rear	618 lbs (280 kg)

Performance data

R 1200 GS

Top speed

more than 124 mph (200 km/h)

Ride-past noise level

According to EU
specification

79 dB (A)

Stationary noise level

According to
EU specification

87 dB (A) at 3,500 rpm

Acceleration

0-62 mph (0-100 km/h)

3.4 s

Tightening torques

R 1200 GS

Front wheel

Brake caliper screws	30 Nm
----------------------	-------

Quick-release axle	50 Nm
--------------------	-------

Axle clamping screw	19 Nm
---------------------	-------

Rear wheel

Wheel studs	60 Nm
-------------	-------

Spark plugs

Primary spark plug	Engine cold	22.5 Nm
--------------------	-------------	---------

Secondary spark plug	Engine cold	22.5 Nm
----------------------	-------------	---------

Battery

Battery-terminal clamps	3.5 Nm
-------------------------	--------

Luggage rack

Luggage rack on rear frame	10 Nm
----------------------------	-------

Some maintenance tasks have to be performed after a certain time, others depend on the distance covered by the motorcycle.

BMW running-in check

The BMW running-in check has to be performed when the motorcycle has covered between 300 miles (500 km) and 700 miles (1,200 km).

BMW Annual Inspection

Some maintenance tasks have to be performed at least once a year.

Other tasks depend on the distance the motorcycle has covered.

BMW Service

After the first 6,000 miles (10,000 km) and every further 12,000 miles (20,000 km) (18,000 miles, 30,000 miles, 42,000 miles) (30,000 km, 50,000 km, 70,000 km...) if covered within a year

BMW Inspection

After the first 12,000 miles (20,000 km) and every further 12,000 miles (20,000 km) (24,000 miles, 36,000 miles, 48,000 miles) (40,000 km, 60,000 km, 80,000 km...) if covered within a year

Maintenance schedules

If you are interested, you can view and download the current maintenance schedule for your motorcycle on the Internet at “www.bmw-motorrad.com/maintenance”.

NOTE

Every BMW Motorrad retailer has a fixed scale of charges based on work times and carefully calculated hourly rates. Fuel, lubricants and similar substances, filters, gaskets, etc. are charged separately.

Confirmation of maintenance

10

174

Service

BMW Pre-delivery Check

Performed in accordance with
manufacturer's instructions

Odometer
reading _____

Date, stamp, signature

BMW Running-In Check

Performed in accordance with
manufacturer's instructions

Odometer
reading _____

Brake fluid changed:

Without BMW Integral ABS

With BMW Integral ABS

Wheel circuit

Control circuit

Date, stamp, signature

Confirmation of maintenance

BMW Service

- BMW Annual Inspection
- BMW Service
- BMW Inspection

Performed in accordance with manufacturer's instructions

Odometer reading _____

Brake fluid changed:

Without BMW Integral ABS

With BMW Integral ABS

- Wheel circuit
- Control circuit

Date, stamp, signature

BMW Service

- BMW Annual Inspection
- BMW Service
- BMW Inspection

Performed in accordance with manufacturer's instructions

Odometer reading _____

Brake fluid changed:

Without BMW Integral ABS

With BMW Integral ABS

- Wheel circuit
- Control circuit

Date, stamp, signature

Confirmation of maintenance

10
176

Service

BMW Service

- BMW Annual Inspection
- BMW Service
- BMW Inspection

Performed in accordance with manufacturer's instructions

Odometer reading _____

Brake fluid changed:

Without BMW Integral ABS

With BMW Integral ABS

- Wheel circuit
- Control circuit

Date, stamp, signature

BMW Service

- BMW Annual Inspection
- BMW Service
- BMW Inspection

Performed in accordance with manufacturer's instructions

Odometer reading _____

Brake fluid changed:

Without BMW Integral ABS

With BMW Integral ABS

- Wheel circuit
- Control circuit

Date, stamp, signature

Confirmation of maintenance

BMW Service

- BMW Annual Inspection
- BMW Service
- BMW Inspection

Performed in accordance with manufacturer's instructions

Odometer reading _____

Brake fluid changed:

Without BMW Integral ABS

With BMW Integral ABS

- Wheel circuit
- Control circuit

Date, stamp, signature

BMW Service

- BMW Annual Inspection
- BMW Service
- BMW Inspection

Performed in accordance with manufacturer's instructions

Odometer reading _____

Brake fluid changed:

Without BMW Integral ABS

With BMW Integral ABS

- Wheel circuit
- Control circuit

Date, stamp, signature

Confirmation of maintenance

10
178

Service

BMW Service

- BMW Annual Inspection
- BMW Service
- BMW Inspection

Performed in accordance with manufacturer's instructions

Odometer reading _____

Brake fluid changed:

Without BMW Integral ABS

With BMW Integral ABS

- Wheel circuit
- Control circuit

Date, stamp, signature

BMW Service

- BMW Annual Inspection
- BMW Service
- BMW Inspection

Performed in accordance with manufacturer's instructions

Odometer reading _____

Brake fluid changed:

Without BMW Integral ABS

With BMW Integral ABS

- Wheel circuit
- Control circuit

Date, stamp, signature

Confirmation of maintenance

10
179

Service

BMW Service

- BMW Annual Inspection
- BMW Service
- BMW Inspection

Performed in accordance with
manufacturer's instructions

Odometer
reading _____

Brake fluid changed:

Without BMW Integral ABS

With BMW Integral ABS

- Wheel circuit
- Control circuit

Date, stamp, signature

BMW Service

- BMW Annual Inspection
- BMW Service
- BMW Inspection

Performed in accordance with
manufacturer's instructions

Odometer
reading _____

Brake fluid changed:

Without BMW Integral ABS

With BMW Integral ABS

- Wheel circuit
- Control circuit

Date, stamp, signature

Confirmation of maintenance

10
180

Service

BMW Service

- BMW Annual Inspection
- BMW Service
- BMW Inspection

Performed in accordance with manufacturer's instructions

Odometer reading _____

Brake fluid changed:

Without BMW Integral ABS

With BMW Integral ABS

- Wheel circuit
- Control circuit

Date, stamp, signature

BMW Service

- BMW Annual Inspection
- BMW Service
- BMW Inspection

Performed in accordance with manufacturer's instructions

Odometer reading _____

Brake fluid changed:

Without BMW Integral ABS

With BMW Integral ABS

- Wheel circuit
- Control circuit

Date, stamp, signature

Now it's your turn

- Regular care is important, with all functions checked before the journey starts.
- Use only genuine BMW accessories. These satisfy all safety requirements and are precisely matched to your BMW motorcycle.
- Have your motorcycle serviced only by the trained, expert personnel at your local authorized BMW Motorrad retailer.
- Do not under any circumstances install unapproved accessories. This can represent a safety risk, invalidate the motorcycle's general operating permit or cause you to lose your insurance cover.
- Technical modifications should always be entrusted to your authorized BMW Motorrad retailer.

NOTE

Your local authorized BMW Motorrad retailer can supply you with useful items to add to your motorcycle's toolkit and accompany the maintenance instructions.

– BMW Repair Manual

It's good to know you've thought of everything, isn't it?

Our aim is to make your journey safer

We want you to reach all your destinations safely – and we want you to enjoy riding your BMW as a constant source of relaxed pleasure and satisfaction.

A

- About this Rider's Manual, 2
- ABS anti-lock brake system, 84
- ABS warning lights, 24, 25
- Adjusting mirror arms, 49
- Adjusting mirrors, 49
- Adjusting seat, 47
- Adjusting shock absorber, 52
- Adjusting spring preload of front wheel, 50
- Adjusting the windshield, 39, 41
- Air filter, 140, 141, 142
- Ambient temperature below 32 °F (0 °C), 67
- Annual Inspection, notes, 173
- Anti-lock braking system
 - deactivating, 88

B

- Battery
 - charging, 146
 - charging when connected, 146
 - charging when disconnected, 148
 - installing, 150
 - removing, 149
 - technical data, 169
 - warranty, 146
- Battery adapter point, 144
- Battery charge current, 19
- Battery maintenance
 - instructions, 146, 147, 148
- BMW Inspection, 173
- BMW Integral ABS, 58
- BMW Motorrad Service Card, 105
- Bore/stroke, 160
- Brake booster, 84
- Brake fluid level
 - checking
 - front brake, 115
- Brake lever movement to limit of travel, 81
- Brake pads, 130
 - rear-wheel brake, 131
- Brake system, 116
 - Brake fluid level, 115
- Brake system -
 - general, 81, 113, 114
- Brake system - with BMW Integral ABS, 82, 83, 84, 85, 86, 87, 88
- Brake system, checking, 113
- Brake-fluid level
 - checking
 - rear brake, 116
- Brakes
 - brake fluid, 168
 - minimum pad thickness, 130
 - pad wear indicator, 130
 - technical data, 162
- Braking-force distribution, 84
- Bulb failure, 19
- Bulbs
 - changing
 - parking light, 138
 - turn indicators, 139
 - information, 132
 - technical data, 169

- Bulbs, changing
 - notes, 132
 - turn indicators, 139

C

- Capacity
 - transmission, 168
- Catalytic converter, 59
 - safety instructions, 59
- Changing case volume, 96
- Checking brake pads, 114
- Checking lights, 43
- Checking oil level, 111
- Checking tire pressures, 53
- Checking wheel rims, 118
- Checking wheel spokes, 118
- Checklist, 61
- Cleaning the windshield, 154
- Cleaning/
 - care, 152, 153, 154, 155
 - general instructions, 152, 154
 - paint damage, 155
 - removing road salt, 154
 - washing, 153
- Clock, 19, 20
- Closing the system case, 96
- Clutch, 161
 - fluid level, 117
- Clutch lever, 40
- Clutch lever, adjusting, 40
- Cockpit, 16
 - general view, 16

- Compression ratio, 160
- Concluding thoughts, 183
- Confirmation of
 - maintenance, 174, 175, 176, 177, 178, 179, 180
- Confirmation of service, 181, 182
- Control unit, electronic engine management system, 108
- Correct loading, 54, 55
- Currency, 5
- Custom equipment, 4

D

- Descending mountain passes, 80
- Digital engine electronics, 58
- Dimensions, 170
- Direction-of-rotation arrow, 123
- Dirt or mud on brakes, 81
- Displacement, 160
- Display
 - engine oil, 112
- Display panel, 19
- Display panel for on-board computer, 19
- Drag coefficient, 171

E

- Electrical accessories, 93
- Electrical system, 169
- Electronic immobilizer (EWS), 30
- Electronic immobilizer active, 19
- Emergency off (kill) switch for ignition, 15

Engine oil, 111, 112
 capacity, 167
 consumption, 160
 oil filler neck, 12, 112
 technical data, 167
 viscosity, 167

Engine speed limit, 160

Engine speed, maximum, 160

Engine temperature, 20

Engine, type, 160

Exhaust emissions, 58

Exhaust system, care
 products, 155

F

Fault in electronic engine
 management system, 19

Filling capacity
 engine, 167

First time out, 62

Flashing turn indicators, indicator
 lights, 18

For your own safety, 5

Frame, 162

Front brake
 Checking brake fluid level, 115

Front brake,
 brake-fluid reservoir, 13

Front seat, adjusting, 47

Front suspension, 50

Front wheel
 technical data, 165

Front-wheel stand, 120

Fuel, 78
 consumption, 160
 grade, 168
 refueling, 78

Fuel and lubricants, 167, 168

Fuel filler cap, 13, 78

Fuel gauge, 79

Fuel level, 19, 20

Fuel tank capacity, 79

Function indicators, 20

Fuses, 169

G

Gear
 ratios, 161

Gear indicator, 19, 20

General view, left side, 12

General view, right side, 13

Gross weight, 55, 170

Ground clearance, 170

H

Handlebar levers,
 clutch lever, 40
 handbrake lever, 41

Handling your motorcycle
 safely, 62

Hazard warning flashers, 32

Headlight beam throw
 adjustment, 43, 44

Headlight setting
 with motorcycle heavily
 loaded, 45

Headlight setting RHD/LHD
 traffic, 44, 45

Heated handlebar grips, 15, 37
High-beam/low-beam headlight switch, 14
Horn push, 14
Hours reading, 38

I
Idle speed, 160
Ignition switch and steering lock, 16, 28
Indicator and warning lights, 18
 ABS, 18
Indicator lights
 Flashing turn indicator, left, 18
 Flashing turn indicator, right, 18
 High-beam headlight, 18
 Neutral, 18
In-key security, 30
Inspection (running-in check), notes, 173
Inspection 600 miles (1,000 km), 173
Installing front wheel, 125
Installing rear wheel, 128
Installing seat, 48
Installing system case, 97
Installing the front wheel, 123
Instruments, cockpit, 16

J
Jump starting, 143, 144, 145

K
Key positions, 29
Keys, 28

Kill switch, 36
Knob
 for spring preload, 51

L
Left handlebar fitting, 14
Length codes, 128
LHD traffic
 headlight adjustment, 44, 45
Loading, 54
low-beam switch, 14
Lube-oil system, 112
Luggage carrier, 100
Luggage
 system, 96, 97, 98, 99, 100, 101

M
Main stand, 76, 77
Maintenance, 173
Maintenance schedules, 173
Marking ring
 display, 112
Massive-bar tires, 119
Minimum permissible tread depth, 119
Minutes reading, 38
Misfiring, 59

N
Neutral, 66
Neutral, selecting, 66

O
Off-road riding, 72, 73
Oil and grease on brakes, 81

Oil capacity
 engine, 167
 transmission, 168
Oil filler neck, 12, 112
Oil level
 check, 112
Oil level check, 111
Oil pressure, 19, 112
Oil temperature, 19
Open the system case, 95
Operating electrical
 accessories, 93
Optional accessories, 3
Optional equipment, 3
Overloading, 54

P

Paralever, 163
Partially integral brakes, 84
Performance data, 171
Pivot lever, 45
Placing motorcycle on main
 stand, 76
Placing motorcycle on side
 stand, 74
Plastics, cleaning, 152
Power output, 160
Power socket, 12, 93
Power socket 12 V
 cable routing, 94
Predrive check, 64
Pull-away test, 87

Q

Quantity of oil, 111
Quick-release axle, 122

R

Rear shock absorber,
 adjusting, 52
Rear wheel
 technical data, 165
Rear wheel drive
 technical data, 161
Rear-wheel brake
 brake pads, 131
Rear-wheel brake,
 brake-fluid reservoir, 13
Refueling, 78
Reliable operation, 104
Removing and installing
 battery, 149, 150
Removing front wheel, 120
Removing luggage rack, 101
Removing motorcycle from main
 stand, 77
Removing motorcycle from side
 stand, 75
Removing rear wheel, 126
Removing road salt, 154
Removing system case, 99
Removing the front wheel, 120
Removing the seat, 46
Replacing air filter element, 140
Replacing parking-light bulb, 138
Replacing turn indicator
 bulbs, 139
Resetting the tripmeter, 35
Residual braking function, 85
Residual range, 34
Returning to use, 157

RHD traffic
 headlight adjustment, 44, 45
Ride-past noise level, 171
Rider Information Display (RID)
 position, 16
Riding, 79
Right handlebar fitting, 15
Rims, 118, 165
Risk of fire, 59
Risk of overheating, 59, 67
Risk of poisoning, 58
Road tires, 119
Running in new brake pads, 69
Running in new tires, 69

S

Safe motorcycling, 63
Safety check, 60
Safety information, 108
Safety instructions, 58, 132
 catalytic converter, 59
Safety instructions,
 braking, 80, 81
Salt damage, 154
Salt on brakes, 80
Screw the valve caps back on
 tightly, 53
Seat, 48
Seat height, 170
Seat lock, 12, 46
Securing bulky luggage, 100
Self-diagnosis with pull-away
 test, 86

Service Card, 105
Service worldwide, 105
Service, notes, 173
Setting the clock, 38
Shift lever, 56
Shifting gear, 79
Shock-absorber adjustment, 52
Side panel, 140
Side stand, 74, 75
Single seat, 48
Spacer bushing, 122
Spare/extra keys, 31
Spark plugs, 169
Speedometer, 16
Spokes, 118
Spring preload,
 front wheel, 50
 rear wheel, 51
Spring travel, 164
Starter pushbutton, 15
Starting, 67
Starting on gradients, 65
Steering lock angle, 163
Storing, Motorcycle, 156
Switch on the ignition, 65, 66
Switching off the hazard warning
 flashers, 33
Switching off the parking light, 42
Switching on low-beam/high-
 beam headlight, 42
Switching on the hazard warning
 flashers, 32
Switching on the parking light, 42
Symbols and abbreviations, 2

- T**
- Tachometer, 16
 - Technical data, from page, 160
 - Technical modifications, 108
 - Technical specifications, 4
 - Telelever, 163
 - The right clothing, 6
 - Tightening torques, 172
 - front wheel, 172
 - front wheel brake caliper, 172
 - Tire tread, 119
 - Tires, 165
 - approved sizes, 165
 - running in, 69
 - technical data, 165
 - tire pressures, 53, 166
 - tread depth, 119, 166
 - Top speed, 171
 - Torque, 160
 - Total distance covered, 34
 - Touching up minor damage, 155
 - Training means extra safety, 106
 - Transmission
 - capacity, 168
 - oil capacity, 168
 - oil grades, 168
 - technical data, 161
 - Tripmeter reading 1, 34
 - Tripmeter reading 2, 34
 - Troubleshooting, 109
 - Troubleshooting chart, 109, 110
 - Turn indicator bulbs, 139
 - Turn indicator switch,
 - left, 14
 - right, 15
 - Type plate, 13, 162
- U**
- Unladen weight, 170
- V**
- Valve caps, 53
- W**
- Warning indicator,
 - battery charge current, 22
 - bulb failure, 22
 - electronic immobilizer, 23
 - engine, 21
 - oil pressure, 21
 - Warning indicators, 21
 - Warning light, general, 18
 - Warning lights
 - ABS, 18
 - general, 18
 - Weights, 170
 - Wet brakes, 80
 - Wheel loads, 55, 170
 - Wheel location, 163
 - Wheel studs
 - length codes, 128
 - Wheelbase, 170
 - Wheels, 118, 119, 120, 123
 - not approved, 119
 - Wheels, technical data, 165

Vehicle/dealership data

Vehicle data

Model

Vehicle identification number

Color code

First registration

Registration number

Dealership data

Contacts in Service Department

Ms./Mr.

Phone number

Dealership address/phone (company stamp)



You might need certain items of information when you stop to refuel, so it is a good idea to write down the important data in this chart.

Fuel

Designation	Super (premium) fuel
RON: Minimum	95

Engine oil

Grade	
The difference between the min. and max. marks is equal to approximately 0.53 qt (0.5 liter).	

Tire pressures	Front	Rear
One-up	31.9 psi (2.20 bar)	36.3 psi (2.50 bar)
With passenger	36.3 psi (2.50 bar)	42 psi (2.90 bar)
Two-up with luggage	36.3 psi (2.50 bar)	42 psi (2.90 bar)

BMW Motorrad Printed information

Order No.:
01 47 7 690 587
05.2004
2nd edition US / RF



The Ultimate
Driving Machine

Please attach this sticker to the inside back cover page of your Rider's Manual

Reporting Safety Defects

If you believe that your vehicle has a defect which could cause a crash or could cause injury or death, you should immediately inform the National Highway Traffic Safety Administration (NHTSA) in addition to notifying BMW of North America, LLC.

If NHTSA receives similar complaints, it may open an investigation, and if it finds that a safety defect exists in a group of vehicles, it may order a recall and remedy campaign. However, NHTSA cannot become involved in

individual problems between you, your dealer, or BMW of North America, LCC.

To contact NHTSA, you may call the Vehicle Safety Hotline toll-free at 1-888-327-4236 (TTY: 1-800-424-9153); go to <http://www.safercar.gov>; or write to: Administrator, NHTSA, 400 Seventh Street, SW., Washington, DC 20590. You can also obtain other information about motor vehicle safety from <http://www.safercar.gov>.

BMW Motorrad

Order No: 01 47 7 706 697

08.2006

Information on BMW Motorrad Integral ABS

How does ABS work?

The maximum braking force which can be transferred to the road surface is partially dependent on the coefficient of friction of the road surface. Gravel, ice, snow and wet road surfaces offer a considerably poorer coefficient of friction than a dry, clean layer of asphalt. The lower the coefficient of friction of the road surface is, the longer the braking distance will be. If the maximum transferrable braking force is exceeded when the driver increases the brake pressure applied, the wheels begin to lock and the driving stability is lost,

resulting in a danger of falling. Before this situation occurs, the ABS intervenes and adjusts the brake pressure to the maximum transferrable braking force. As a result, the wheels continue to turn and the driving stability is maintained regardless of the road surface condition.

What happens on uneven road surfaces?

Wavy ground or uneven road surfaces can briefly result in a loss of contact between the tire and the road surface, and the transferrable braking force decreases to zero. If the brakes are applied in this situation, the ABS must reduce the brake pressure to

ensure driving stability when contact with the road surface is restored. At this point in time the BMW Motorrad Integral ABS must assume extremely low coefficients of friction (gravel, ice or snow) so that the wheels turn in every imaginable case and the driving stability is ensured. After the actual conditions are detected, the system adjusts the brake pressure to the optimum value.

What must be observed during driving safety training?

Compared to normal braking, braking during which the ABS must intervene in a regulating manner requires a consider-

ably increased amount of current, which places a heavy load on the battery.

During normal driving the battery is constantly charged, and therefore has a sufficient capacity.

During driving breaks of several weeks, a trickle-charger available from an authorized BMW Motorrad retailer should be connected or the battery should be disconnected and recharged before the next time the motorcycle is driven.

During driving-safety training courses an unusually high number of ABS-controlled braking actions take place within a short time. Between those actions there are waiting and evaluation phases during which the motorcycle is not

driven. The battery is heavily loaded by the ABS control actions, however at the same time it is not recharged, as virtually no driving takes place. In isolated cases, braking actions of this kind in this artificially produced situation during which the brake lever is pulled with maximum force and extremely quickly, in combination with a decreasing electrical system voltage, push the ABS to technical limits at which the control function is no longer fulfilled. Field observations by BMW Motorrad show that no comparable situations occur in road traffic or during circuit training.

During safety training the following instructions must be followed:

- Observe the warning and control lights before each braking exercise
- Drive a longer distance after a maximum of five braking exercises to charge the battery
- Switch off consumers like seat and hand grip heaters, radio, navigation system and accessories connected to the sockets
- Switch off the ignition during breaks and conversations. If the engine is switched off with the emergency ON/OFF switch, the light and all electronic systems remain switched on and load the battery

How can the shortest braking distance be achieved?

During braking the dynamic load distribution between the front and rear wheel changes. The heavier braking is, the higher the load on the front wheel. The greater the wheel load, the more braking force can be transferred.

To achieve the shortest possible braking distance, the front brake must be operated quickly and with increasing force. This optimally utilizes the dynamic load increase on the front wheel. At the same time, the clutch should also be disengaged.

With the "forced braking" often practiced, during which the brake pressure is generated

as quickly as possible and with maximum force, the dynamic load distribution is unable to follow the increase in deceleration and the brake force cannot be completely transferred to the road surface. To prevent locking of the front wheel, the ABS must intervene and reduce the brake pressure, which increases the braking distance.

What happens when the ABS control function fails?

A fault in the BMW Motorrad Integral ABS is indicated by a corresponding warning in the instrument cluster.

If only the ABS control function fails, the integral system and the brake booster continue to operate. If these systems also

fail, the residual braking function is activated. In this case, the forces to be applied to the brake levers are considerably higher and the required lever travel increases.

The residual braking function is a mechanical function and is always available when the BMW Motorrad Integral ABS fails, regardless of the battery charging level. It meets all requirements of the worldwide legislation on the brake design of motor vehicles and enables the rider to brake the motorcycle.

When driving with the residual braking function, the following instructions must be followed:

- Adjust the brake levers to the maximum travel

- Always brake with the front and rear brakes
- In clear situations, carry out test braking to learn the response behavior of the brakes
- Observe the condition of the road surface and adapt the braking force applied accordingly
- As it is an emergency running function, you should drive to a specialized workshop, preferably an authorized BMW Motorrad retailer, as quickly as possible

How important is regular maintenance?



Any technical system is always only as good as its maintenance status. To ensure that the BMW Motorrad Integral ABS is in optimum condition with regard to maintenance, the specified inspection intervals must always be complied with. ◀

How is the BMW Motorrad Integral ABS designed?

The BMW Motorrad Integral ABS ensures the driving stability of the motorcycle on any surface within the physical limits of driving. The system is not optimized for special requirements resulting under extreme weather conditions on offroad terrain or on racing circuits.

BMW Motorrad

Order No.:
01 47 7 699 277
07.2005
1st edition US/RF



The Ultimate
Riding Machine

Subject: Motorcycles with hand protectors

Malfunctions due to twisted hand protector

If the hand protector and the handlebar lever are twisted relative to each other so that they touch, a permanent actuation of the respective handlebar lever can result. This can lead to faults in clutch or brake operation.

Possible causes include:

- Accident or fall
- Improper transport
- Loose threaded connections
- Impermissible ergonomic settings (see Rider's Manual "Adjusting clutch/ handlebar lever" or "Adjusting brake/handlebar lever")
- Always check the smooth movement of the clutch and brake lever before driving off.

Checking smooth movement of handlebar levers

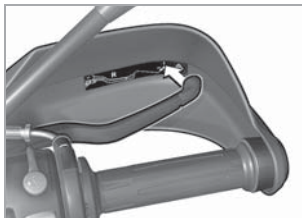

Smooth movement is ensured when

- a finger fits between the handlebar lever and the hand protector
- or
- the handlebar lever can easily be moved forward out of the rest position.

Aligning hand protector

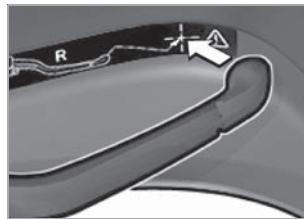

- Press the handlebar lever forward. Twist the hand protector so that the end of the handlebar lever touches the cross on the adhesive label.
- Have adjustments and torques checked by a specialized workshop, preferably by an authorized BMW Motorrad retailer.



Note on safety