



**BMW
MOTORRAD**

RIDER'S MANUAL

K 1600 B



MAKE LIFE A RIDE

Vehicle data

Model

Vehicle Identification Number

Colour code

Date of first registration

Registration number

Dealership details

Person to contact in Service department

Ms/Mr

Phone number

Dealership address/phone number (company stamp)

YOUR BMW.

We congratulate you on your choice of a vehicle from BMW Motorrad and welcome you to the community of BMW riders. Familiarise yourself with your new vehicle so that you can ride it safely and confidently in all traffic situations.

About this rider's manual

Read this rider's manual carefully before starting to use your new BMW. It contains important information on how to operate the controls and how to make the best possible use of all your BMW's technical features.

In addition, it contains information on maintenance and care to help you maintain your vehicle's reliability and safety, as well as its value.

If the time comes to sell your BMW, please remember to hand over this rider's manual to the new owner. It is an important part of the vehicle.

We hope you will enjoy riding your BMW and that all your journeys will be pleasant and safe

BMW Motorrad.

01 GENERAL INSTRUCTIONS	2	03 STATUS INDICATORS	26
Quick & easy reference	4	Indicator and warning lights	28
Abbreviations and symbols	4	TFT display in Pure Ride view	29
Equipment	5	TFT display in Menu view	30
Technical data	5	Warning indicators	31
Currency	6		
Additional sources of information	6	04 OPERATION	62
Certificates and operating licences	6	Ignition switch/steering lock	64
Data memory	6	Ignition with Keyless Ride	65
Intelligent emergency call system	11	Emergency-off switch (kill switch)	71
		Intelligent emergency call	71
02 GENERAL VIEWS	16	Lighting	74
General view, left side	18	Anti-theft alarm (DWA)	79
General view, right side	19	Dynamic Traction Control (DTC)	82
Overall view of cockpit	20	Electronic Suspension Adjustment (D-ESA)	82
Underneath the seat	21	Riding mode	83
Multifunction switch, left	22	Adaptive cruise control	84
Multifunction switch, right	23	Hill Start Control	87
Multifunction switch, right	24	Reverser	89
Instrument cluster	25	Central locking system	90
		Heating	91
		Slipstream deflector	93
		Seat	94
		Cases	94
		Storage compartments	96

05 TFT DISPLAY	100	08 RIDING	142
General notes	102	Safety information	144
Principle	103	Regular check	147
Pure Ride view	109	Starting	147
Splitscreen	110	Running in	150
General settings	111	Shifting gear	151
Bluetooth	112	Brakes	151
WIFI	115	Parking your motorcycle	154
My vehicle	116	Refuelling	155
On-board computer	119	Securing motorcycle for transportation	160
Navigation	120		
Media	122		
Telephone	123		
Favourites buttons	124		
Display software version	124	09 ENGINEERING DETAILS	162
Display licence information	124	General notes	164
		Antilock Brake System (ABS)	164
06 AUDIO SYSTEM	126	Dynamic Traction Control (DTC)	168
Radio	128	Dynamic engine brake control	169
Audio settings	130	Electronic chassis and suspension adjustment	170
Player	132	Riding mode	170
Satellite radio	132	Tyre pressure monitoring (RDC)	172
HD Radio Empfang	134	Gear Shift Assistant	173
In-helmet audio playback	135	Hill Start Control	174
		Adaptive headlight	176
07 ADJUSTMENT	136		
Mirrors	138		
Windscreen	138		
Clutch	139		
Brakes	139		

10 MAINTENANCE	178	13 TECHNICAL DATA	218
General notes	180	Troubleshooting chart	220
Toolkit	180	Threaded fasteners	223
Front-wheel stand	181	Fuel	225
Rear-wheel stand	182	Engine oil	226
Engine oil	182	Engine	226
Brake system	184	Clutch	227
Clutch	189	Transmission	227
Coolant	189	Final drive	228
Tyres	190	Frame	228
Wheel rims	191	Chassis and suspension	228
Wheels	191	Brakes	229
Lighting	198	Wheels and tyres	229
Jump-starting	198	Electrical system	230
Battery	200	Anti-theft alarm	231
Fuses	204	Dimensions	232
Diagnostic connector	205	Weights	232
		Performance figures	232
11 ACCESSORIES	208		
General notes	210	14 SERVICE	234
Power sockets	210	Reporting safety-relevant defects	236
12 CARE	212	BMW Motorrad Service	237
Care products	214	BMW Motorrad Service history	237
Washing the vehicle	214	BMW Motorrad Mobility services	238
Cleaning easily damaged components	215	Maintenance work	238
Care of paintwork	216	Maintenance schedule	240
Vehicle preservation	217	Maintenance confirmations	241
Laying up motorcycle	217	Service confirmations	253
Restoring motorcycle to use	217		

APPENDIX	256
Declaration of Con-	
formity	257
Certificate for TFT	
instrument cluster	262
Certificate for audio	
system	266
Certificate for elec-	
tronic immobiliser	267
Certificate for Key-	
less Ride	270
Certificate for tyre	
pressure control (Re-	
ifendruck-Control,	
RDC)	274
Emergency call	275

INDEX	280
--------------	------------

GENERAL INSTRUCTIONS

01

QUICK & EASY REFERENCE	4
ABBREVIATIONS AND SYMBOLS	4
EQUIPMENT	5
TECHNICAL DATA	5
CURRENCY	6
ADDITIONAL SOURCES OF INFORMATION	6
CERTIFICATES AND OPERATING LICENCES	6
DATA MEMORY	6
INTELLIGENT EMERGENCY CALL SYSTEM	11

4 GENERAL INSTRUCTIONS

QUICK & EASY REFERENCE

Chapter 2 of these operating instructions will provide you with an initial overview of your motorcycle. All maintenance and servicing work on the motorcycle is documented in the "Service" section. The record of the maintenance work you have had performed on your vehicle is a precondition for generous treatment of goodwill claims. If the time comes to sell your BMW, please remember to hand over these operating instructions to the new owner. They are an important part of the motorcycle.

ABBREVIATIONS AND SYMBOLS

 **CAUTION** Low-risk hazard. Non-avoidance can lead to slight or moderate injury.

 **WARNING** Medium-risk hazard. Non-avoidance can lead to fatal or severe injury.

 **DANGER** High-risk hazard. Non-avoidance leads to fatal or severe injury.

 **ATTENTION** Special notes and precautionary measures. Non-compliance can lead

to damage to the vehicle or accessory and, consequently, to voiding of the warranty.

 Specific instructions on how to operate, control, adjust or look after items of equipment on the motorcycle.

• Instruction.

» Result of an activity.

 Reference to a page with more detailed information.

◁ Indicates the end of a passage relating to specific accessories or items of equipment.

 Tightening torque.

 Technical data.

NV National-market version.

OE Optional equipment. The vehicles are assembled complete with all the BMW Motorrad optional equipment originally ordered.

- OA Optional accessories. You can obtain BMW Motorrad optional accessories through your authorised BMW Motorrad dealer; optional accessories have to be retrofitted to the vehicle.
- ABS Anti-lock brake system.
- D-ESA Electronic chassis and suspension adjustment.
- DTC Dynamic Traction Control.
- DWA Anti-theft alarm.
- EWS Electronic immobiliser.
- RDC Tyre pressure monitoring.

EQUIPMENT

When you ordered your BMW Motorrad, you chose various items of custom equipment. These operating instructions describe the optional equipment (OE) offered by BMW and selected optional accessories (OA). This explains why the manual may also contain descriptions

of equipment that you might not have selected. Please note, too, that on account of country-specific differences, your motorcycle might not be exactly as illustrated. If your motorcycle contains equipment that has not been described, its description can be found in a separate manual.

TECHNICAL DATA

All dimensions, weights and power ratings stated in the operating instructions are quoted to the standards and comply with the tolerance requirements of the Deutsches Institut für Normung e.V. (DIN). Technical data and specifications in this rider's manual serve as reference points. The vehicle-specific data may deviate from these, for example as a result of selected optional equipment, the national-market version or country-specific measuring procedures. Detailed values can be taken from the vehicle registration documents, or can be obtained from your authorised BMW Motorrad retailer or another qualified service partner or specialist workshop. The specifications in the vehicle documents always

6 GENERAL INSTRUCTIONS

have priority over the information provided in this rider's manual.

CURRENCY

The high safety and quality standards of BMW motorcycles are maintained by constant development work on designs, equipment and accessories. Because of this, your motorcycle may differ from the information supplied in the Rider's Manual. Nor can BMW Motorrad entirely rule out errors and omissions. We hope you will appreciate that no claims can be entertained on the basis of the data, illustrations or descriptions in these operating instructions.

ADDITIONAL SOURCES OF INFORMATION

Authorised BMW Motorrad retailer

Your authorised BMW Motorrad retailer will be happy to answer any questions you may have.

Internet

The rider's manual for your vehicle, operating and installation instructions for accessories and general information about BMW Motorrad, in relation to

technology, for example, are available for download from bmw-motorrad.com/manuals.

CERTIFICATES AND OPERATING LICENCES

The certificates for the vehicle and the official operating licences for accessories can be downloaded from bmw-motorrad.com/certification.

DATA MEMORY

General

Control units are installed in the vehicle. Control units process data that they receive, for example, from vehicle sensors, or that they generate themselves or exchange between each other. Some control units are required for the vehicle to function safely or provide assistance during riding, for example assistance systems. In addition, control units enable comfort or infotainment functions.

Information on data that has been stored or exchanged can be obtained from the manufacturer of the vehicle, for example via a separate booklet.

Personal reference

Each vehicle is identified with a clear vehicle identification number. Depending on the country, the vehicle identification number, the number plate and the corresponding authorities can be referenced to ascertain the vehicle owner. There are also other ways to use data obtained from the vehicle to trace the rider or vehicle owner, for example using the Connected-Drive user account.

Data protection rights

In accordance with applicable data protection laws, vehicle users have certain rights in relation to the manufacturer of the vehicle or in relation to companies which collect or process personal data. Vehicle users have the right to obtain full information at no cost from persons or entities storing personal data of the vehicle user.

These entities may include:

- Manufacturer of the vehicle
- Qualified service partners
- Specialist workshops
- Service providers

Vehicle users have the right to request information on what personal data has been stored, for what purpose the data

is used, and where the data comes from. To obtain this information, proof of ownership or use is required.

The right to information also includes information about data that has been shared with other companies or entities. The website of the vehicle manufacturer contains the applicable data protection information. This data protection information includes information on the right to have data deleted or corrected. The manufacturer of the vehicle also provides their contact details and those of the data protection officer on their website.

The vehicle owner can also request that a BMW Motorrad retailer or another qualified service partner or specialist workshop read out the data that is stored in the vehicle for a charge.

The vehicle data is read out using the legally prescribed socket for on-board diagnosis (OBD) in the vehicle.

8 GENERAL INSTRUCTIONS

Legal requirements for the disclosure of data

As part of its legal responsibilities, the manufacturer of the vehicle is obligated to make its stored data available to the relevant authorities. This data is provided in the required scope in individual cases, for example to clarify a criminal offence. In the context of applicable laws, public agencies are entitled in individual cases to read out data from the vehicle themselves.

Operating data in the vehicle

Control units process data to operate the vehicle.

This includes, for example:

- Status reports of the vehicle and its individual components, for example wheel speed, wheel circumferential velocity, deceleration
- Environmental conditions, for example temperature

The data is only processed in the vehicle itself and is generally non-permanent. The data is not stored beyond the operating period.

Electronic components, for example control units, contain components for storing technical information. Information can be temporarily or perman-

ently stored on the vehicle condition, component loads, incidents or errors.

This information is generally used to document the condition of a component, a module, a system or the surrounding area, for example:

- Operating conditions of system components, for example filling levels, tyre pressure
- Malfunctions and faults in important system components, for example light and brakes
- Response of the vehicle in special riding situations, for example engagement of the driving dynamics systems
- Information on incidents resulting in damage to the vehicle

The data is necessary for the provision of control unit functions. Furthermore, the data is used to detect and rectify malfunctions and to enable the vehicle manufacturer to optimise vehicle functions.

The vast majority of this data is non-permanent and is only processed in the vehicle itself. Only a small amount of the data is stored in incident or fault memories as required by events.

If services are accessed, for example repairs, service processes, warranty cases and quality assurance measures, this technical information can be read out of the vehicle together with the vehicle identification number.

The information can be read out by a BMW Motorrad retailer or another qualified service partner or specialist workshop. The legally stipulated socket for on-board diagnosis (OBD) in the vehicle is used to read out the data.

The data is obtained, processed and used by the relevant parts of the retailer network. The data is used to document the technical conditions of the vehicle, to help with error localization, to comply with warranty obligations and to improve quality.

In addition, the manufacturer has various product monitoring obligations arising from product liability legislation. To meet these obligations, the vehicle manufacturer requires technical data from the vehicle. The data from the vehicle can also be used to check warranty claims from the customer.

Error and incident memories in the vehicle can be reset during servicing or repair work by a BMW Motorrad retailer or another qualified service partner or specialist workshop.

Data input and data transfer in the vehicle

General

Depending on the equipment, comfort and customised settings can be stored in the vehicle and can be changed or reset at any time.

If required, data can be entered in the entertainment and communication system of the vehicle, for example using a smartphone.

Depending on the individual equipment, this includes:

- Multimedia data, such as music for playback
- Contacts data for use in connection with a communication system or an integrated navigation system
- Entered destinations
- Data on the use of internet services. This data can be stored locally in the vehicle or is located on a device that is connected to the vehicle, for example smartphone, USB stick, MP3 player. If this data is stored in the vehicle, the

10 GENERAL INSTRUCTIONS

data can be deleted at any time.

This data is transferred to third parties only if personally requested within the context of using online services. This depends on the selected settings when using the services.

Incorporation of mobile devices

Depending on the equipment, mobile devices connected to the vehicle, for example smartphones, can be controlled using the operating elements of the vehicle.

The image and sound of the mobile device can then be output via the multimedia system.

At the same time, specific information is transferred to the mobile device. Depending on the type of integration, this includes, for example, position data and additional general vehicle information. This enables optimal use of the selected apps, for example navigation or music playback.

The type of additional data processing is determined by the provider of the respective app. The scope of the possible settings depends on the corresponding app and the operating system of the mobile device.

Services

General

If the vehicle has a wireless connection, this enables the exchange of data between the vehicle and other systems. The wireless connection is enabled by the vehicle's own transceiver unit or using personally integrated mobile devices, for example smartphones. Online functions can be accessed through this wireless connection. These include online services and apps that are provided by the vehicle manufacturer or by other providers.

Services of the vehicle manufacturer

For online services of the vehicle manufacturer, the individual functions are described at suitable points, for example rider's manual, website of the manufacturer. At the same time, information is also provided on the relevant data protection law. Personal data may be used to provide online services. Data is exchanged using a secure connection, for example with the IT systems provided by the vehicle manufacturer.

Obtaining, processing and using personal data outside of the normal provision of services requires legal permission, contractual agreement or consent. It is also possible to have the entire data connection activated or deactivated. Statutory functions are excluded from this.

Services from other providers

When using online services from other providers, these services are subject to the responsibility and the data protection and operating conditions of the individual provider. The vehicle manufacturer has no influence on the content that is exchanged in this instance. Information on the type, scope and purpose of the data capture and use of personal data as part of the services of third parties can be ascertained from the individual provider.

INTELLIGENT EMERGENCY CALL SYSTEM

–with intelligent emergency call^{OE}

Principle

The intelligent emergency call system enables manual or automatic emergency calls, for example in the event of an accident.

The emergency calls are received by an emergency call centre that is commissioned by the vehicle manufacturer. For information on operating the intelligent emergency call system and its functions see (▣▣▣▣ 71).

Legal basis

Processing of personal data using the intelligent emergency call system is in line with the following regulations:

- Protection of personal data: Directive 95/46/EC of the European Parliament and of the Council.
- Protection of personal data: Directive 2002/58/EC of the European Parliament and of the Council.

The legal basis for the activation and function of the intelligent emergency call system is the concluded ConnectedRide contract for this function, as well as the corresponding laws, ordinances and directives of

12 GENERAL INSTRUCTIONS

the European Parliament and of the European Council.

The relevant ordinances and directives regulate the protection of natural persons during the processing of personal data.

The processing of personal data by the intelligent emergency call system satisfies the European directives for the protection of personal data.

The intelligent emergency call system processes personal data only with the agreement of the vehicle owner.

The intelligent emergency call system and other services with additional benefits may only process personal data with the express permission of the person affected by the data processing, for example the vehicle owner.

SIM card

The intelligent emergency call system operates via the mobile phone network using the SIM card installed in the vehicle.

The SIM card is permanently logged into the mobile phone network to enable rapid connection setup. Data is sent to the vehicle manufacturer in the event of an emergency.

Improving quality

The data that is transferred in an emergency is also used by the manufacturer of the vehicle to improve product and service quality.

Location determination

The position of the vehicle can be determined exclusively by the mobile phone network provider based on the mobile phone site locations. It is not possible for the provider to trace a connection between the vehicle's VIN and the phone number of the installed SIM card. Only the manufacturer of the vehicle can link a VIN and the phone number of the SIM card installed in a particular vehicle.

Log data of emergency calls

The log data of emergency calls is stored in a memory of the vehicle. The oldest log data is regularly deleted. The log data includes, for example, information on when and where an emergency call was made. In exceptional cases, the log data can be read out of the vehicle memory. As a rule, log data is only read out following a court order, and this is only possible if the corresponding

devices are connected directly to the vehicle.

Automatic emergency call

The system is designed so that, following a sufficiently serious accident, which is detected by sensors in the vehicle, an emergency call is automatically activated.

Sent information

When making an emergency call using the intelligent emergency call system, the system forwards the same information to the designated emergency call centre as is forwarded to the public emergency operations centre by the statutory emergency call system eCall. In addition, the intelligent emergency call system sends the following additional information to an emergency call centre commissioned by the vehicle manufacturer and, if required, to the emergency services:

- Accident data, for example the direction of impact detected by the vehicle sensors, to assist the emergency services response.
- Contact details, for example the phone number of the SIM card installed in the vehicle

and, if available, the phone number of the rider, to enable rapid contact with those involved in the accident if the need arises.

Data storage

The data for an activated emergency call is stored in the vehicle. The data contains information on the emergency call, for example the location and time of the emergency call. The voice recordings of the emergency call are stored at the emergency call centre. The voice recordings of the customer are stored for 24 hours in case details of the emergency call need to be analysed. After this, the voice recordings are deleted. The voice recordings of the employee of the emergency call centre are stored for 24 hours for quality assurance purposes.

Information on personal data

The data that is processed as part of the intelligent emergency call is processed exclusively to carry out the emergency call. As part of its statutory obligation, the manufacturer of the vehicle provides information about the data that

14 GENERAL INSTRUCTIONS

it has processed and any data
that it still has stored.

GENERAL VIEWS

02

GENERAL VIEW, LEFT SIDE	18
GENERAL VIEW, RIGHT SIDE	19
OVERALL VIEW OF COCKPIT	20
UNDERNEATH THE SEAT	21
MULTIFUNCTION SWITCH, LEFT	22
MULTIFUNCTION SWITCH, RIGHT	23
MULTIFUNCTION SWITCH, RIGHT	24
INSTRUMENT CLUSTER	25

18 GENERAL VIEWS

GENERAL VIEW, LEFT SIDE

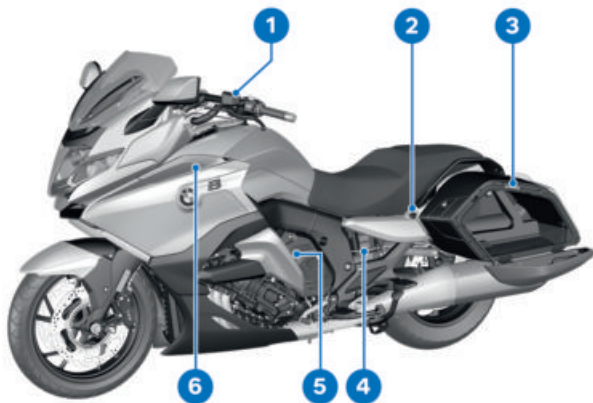

- 1 Clutch-fluid reservoir
(189)
- 2 Passenger-seat socket for accessories (210)
- 3 Seat unlocking (94)
- 4 Payload table
Tyre pressures table
- 5 Storage compartment
(96)
- 6 Slipstream deflector
(93)

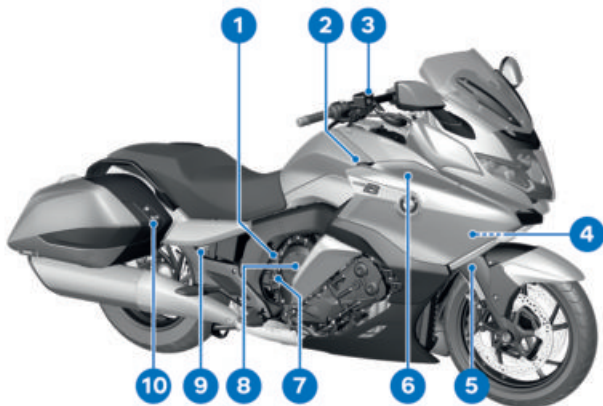
GENERAL VIEW, RIGHT SIDE

- | | |
|---|--|
| <p>1 Engine number (above oil filler neck)
Vehicle identification number (above the oil filler neck on the rear part of the main frame)</p> <p>2 Power socket (► 210)</p> <p>3 Brake-fluid reservoir, front (► 186)</p> <p>4 Coolant level indicator (behind the side trim panel) (► 189)</p> <p>5 Type plate (wheel carrier, front right)</p> <p>6 Slipstream deflector (► 93)</p> | <p>7 Oil filler opening (► 182)</p> <p>8 Storage compartment (► 96)</p> <p>9 Brake-fluid reservoir, rear (► 188)</p> <p>10 Passenger seat heating (► 92)</p> |
|---|--|

20 GENERAL VIEWS

OVERALL VIEW OF COCKPIT

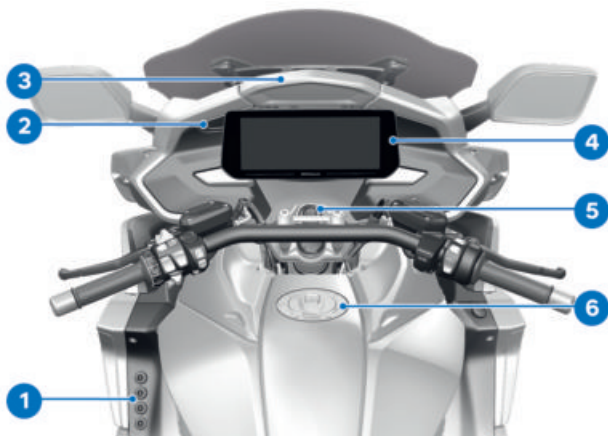

- 1 Favourites buttons (☛ 124)
- 2 Button, charging storage compartment (☛ 96)
- 3 Charging storage compartment (☛ 96)
- 4 TFT display (☛ 29)
- 5 Ignition switch/steering lock (☛ 64)
- 6 Fuel filler neck (☛ 156)

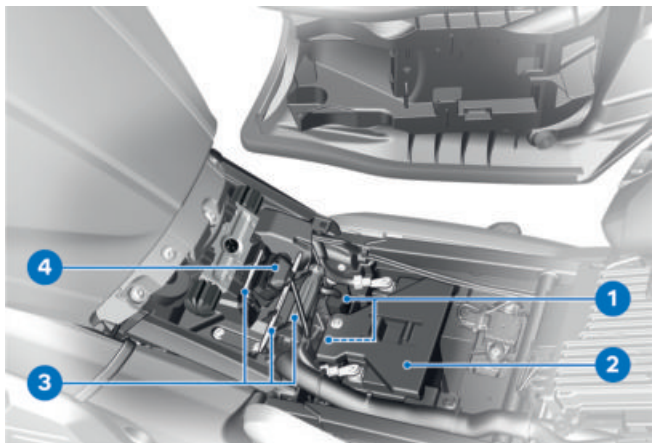
UNDERNEATH THE SEAT

- 1 Fuses (▮▮▮▮ 204)
- 2 Battery (▮▮▮▮ 200)
- 3 Toolkit (▮▮▮▮ 180)
- 4 Diagnostic connector (▮▮▮▮ 205)

22 GENERAL VIEWS

MULTIFUNCTION SWITCH, LEFT



- 1 High-beam headlight and headlight flasher (➡ 74)
- 2 Adaptive cruise control (➡ 85)
- 3 Hazard warning lights (➡ 77)
- 4 Windscreen (➡ 138)
- 5 Reverser (➡ 89)
- 6 Auxiliary headlights (➡ 75)
- 7 Turn indicators (➡ 78)
- 8 Horn
- 9 MENU rocker button (➡ 103)
- 10 Multi-Controller (➡ 103)
- 11 Daytime riding light (➡ 76)

MULTIFUNCTION SWITCH, RIGHT

–with intelligent emergency call^{OE}



- 1** Central locking system
(➡ 90)
- 2** Riding mode (➡ 83)
- 3** Emergency-off switch (kill switch) (➡ 71)
- 4** Starter button (➡ 147)
- 5** SOS button
Intelligent emergency call
(➡ 71)

24 GENERAL VIEWS

MULTIFUNCTION SWITCH, RIGHT

—without intelligent emergency call^{OE}

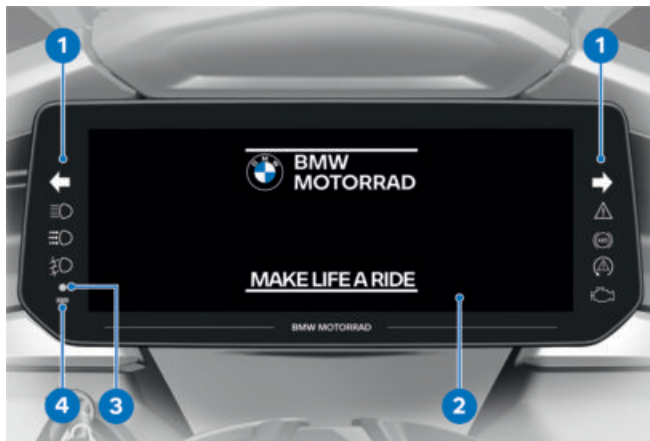

- 1 Central locking system (➡ 90)
- 2 Riding mode (➡ 83)
- 3 Emergency-off switch (kill switch) (➡ 71)
- 4 Starter button (➡ 147)

INSTRUMENT CLUSTER

- 1 Indicator and warning lights (➡ 28)
- 2 TFT display (➡ 29)
- 3 Indicator light
DWA (➡ 80)
Keyless Ride (➡ 65)
- 4 Photosensor (for adapting the brightness of the instrument lighting)

STATUS INDICATORS

03

INDICATOR AND WARNING LIGHTS	28
TFT DISPLAY IN PURE RIDE VIEW	29
TFT DISPLAY IN MENU VIEW	30
WARNING INDICATORS	31

28 STATUS INDICATORS

INDICATOR AND WARNING LIGHTS



- 1 Turn indicators, left (➡ 78)
- 2 High-beam headlight (➡ 74)
- 3 General warning light (➡ 31)
- 4 Turn indicators, right (➡ 78)
- 5 Warning light, drive malfunction (➡ 46)
- 6 DTC (➡ 54)
- 7 ABS (➡ 53)
- 8 Daytime riding light (➡ 76)
- 9 Auxiliary headlights (➡ 75)

TFT DISPLAY IN PURE RIDE VIEW

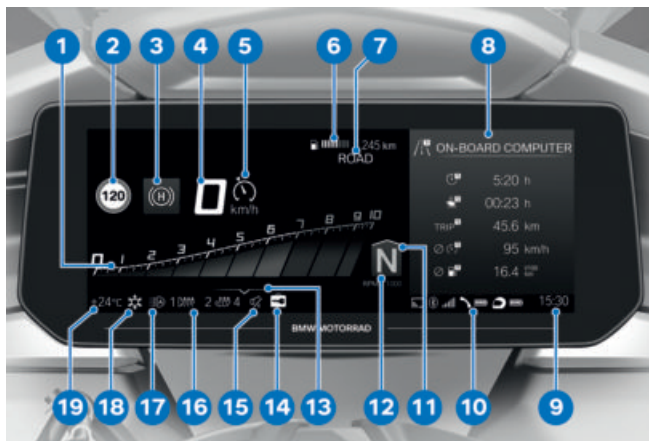

- | | |
|--|--|
| 1 Rev. counter (➡ 109) | 12 Gear indicator; "N" indicates neutral. |
| 2 Speed Limit Info (➡ 108) | 13 Operating pointer (➡ 104) |
| 3 Hill Start Control (➡ 87) | 14 Central locking system (➡ 90) |
| 4 Speedometer | 15 Muting (➡ 111) |
| 5 Adaptive cruise control (➡ 85) | 16 Heating (➡ 91) |
| 6 Rider info. status line (➡ 107) | 17 Automatic daytime riding light (➡ 77) |
| 7 Riding mode (➡ 83) | 18 Outside temperature warning (➡ 39) |
| 8 Splitscreen (➡ 110) | 19 Ambient temperature |
| 9 Clock (➡ 111) | |
| 10 Connection status (➡ 113) | |
| 11 Recommendation to up-shift (➡ 110) | |

30 STATUS INDICATORS

TFT DISPLAY IN MENU VIEW



- | | |
|---|---|
| 1 Hill Start Control (►►► 87) | 12 Muting (►►► 111) |
| 2 Speedometer | 13 Heating (►►► 91) |
| 3 Adaptive cruise control (►►► 85) | 14 Automatic daytime riding light (►►► 77) |
| 4 Rider info. status line (►►► 107) | 15 Outside temperature warning (►►► 39) |
| 5 Riding mode (►►► 83) | 16 Ambient temperature |
| 6 Gear indicator; "N" indicates neutral. | 17 Menu section |
| 7 Splitscreen (►►► 110) | |
| 8 Clock (►►► 111) | |
| 9 Connection status (►►► 113) | |
| 10 Operating pointer (►►► 104) | |
| 11 Central locking system (►►► 90) | |

WARNING INDICATORS

Mode of presentation

Warnings are indicated by the corresponding warning lights. Warnings are indicated by the 'General' warning light showing in combination with a dialogue in the TFT display. The 'General' warning light shows yellow or red, depending on the urgency of the warning.



The status of the 'General' warning light matches the most urgent warning. The possible warnings are listed on the next pages.

- Green CHECK OK **1**: No message, optimum values.
- White circle with small "i" **2**: Information.
- Yellow warning triangle **3**: Warning, value not ideal.
- Red warning triangle **3**: Warning, value critical.



Values display

Symbols **4** differ in how they show on the display. The colours used differ and reflect the urgency of the message. Along with numerical values **8** with units **7**, texts **6** are displayed as well:

Colour of the symbol

- Green: (OK) Current value is ideal.
- Blue: (Cold!) Current temperature is low.
- Yellow: (Low!/High!) Current value is too low or too high.
- Red: (Hot!/High!) Current temperature or value is too high.

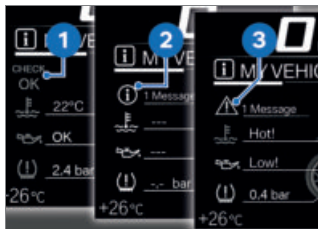

Check Control display

The messages differ in how they show on the display. Different colours and symbols are used depending on priority:

32 STATUS INDICATORS

–White: (---) No valid value available. Dashes **5** are displayed instead of a numerical value.

 The assessment of some values is only possible from a certain journey duration or speed. If a measured value is still not being displayed because the conditions for measurement have not been met, dashes are displayed instead as a placeholder. If there are no valid measured values, there will be no assessment in the form of a coloured symbol.

ledged by tilting the Multi-Controller to the left.

–Check Control messages are attached dynamically to the pages as additional tabs in the **My vehicle** menu ( 105). The message can be called up again as long as the fault persists.

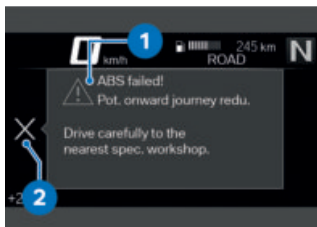





















Check Control dialogue



















Messages are output as Check Control dialogues **1**.



















- If there are two or more Check Control messages of equal priority, the messages keep changing in the order of their occurrence until they are acknowledged.
- If symbol **2** is actively displayed, it can be acknow-

Warnings, overview





















Indicator and warning lights	Display text	Meaning
	 is displayed.	Outside temperature warning (➡ 39)
 lights up yellow.	 Remote key not in range.	Radio-operated key out of range (➡ 39)
 lights up yellow.	 Keyless Ride failure	Keyless Ride failed (➡ 40)
 lights up yellow.	 Remote key battery weak.	Replace the battery of the radio-operated key (➡ 40)
	 is displayed in yellow.	Voltage of the vehicle electrical system too low (➡ 40)
	 Vehicle voltage low.	
 lights up yellow.	 is displayed in yellow.	Voltage of the vehicle electrical system critical (➡ 41)
	 Vehicle voltage critical!	
 flashes yellow.	 is displayed in yellow.	Charging voltage critical (➡ 41)
	 Battery voltage critical!	
 lights up yellow.	 The faulty bulb is displayed.	Bulb faulty (➡ 42)
 flashes yellow.	 The faulty bulb is displayed.	
 lights up yellow.	 Light control failure!	Light control failed (➡ 43)















34 STATUS INDICATORS

Indicator and warning lights	Display text	Meaning
	 Alarm system batt. capacity weak.	Anti-theft alarm battery weak (▶▶▶▶ 43)
	 Alarm system battery empty.	Anti-theft alarm battery flat (▶▶▶▶ 44)
	 Alarm system failure	DWA failed (▶▶▶▶ 44)
 lights up yellow.	 Engine oil level Check engine oil level.	Engine-oil level too low (▶▶▶▶ 45)
 lights up yellow.	 Coolant temperature too high!	Coolant temperature too high (▶▶▶▶ 45)
 lights up.	 Engine!	Drive malfunction (▶▶▶▶ 46)
 flashes red.	 Serious fault in the engine control!	Serious drive malfunction (▶▶▶▶ 46)
 flashes.		
 lights up yellow.	 No communication with engine control.	Engine control failed (▶▶▶▶ 46)
 lights up.		
 lights up yellow.	 Fault in the engine control.	Engine in emergency-operation mode (▶▶▶▶ 46)
 flashes red.	 Serious fault in the engine control!	Serious fault in engine control (▶▶▶▶ 47)







Indicator and warning lights	Display text	Meaning
 lights up yellow.	 is displayed in yellow.	Tyre pressure close to limit of permitted tolerance (➡ 49)
	 Tyre pressure does not match setpoint	
 flashes red.	 is displayed in yellow.	Tyre pressure outside permitted tolerance (➡ 49)
	 Tyre pressure does not match setpoint	
	 Tyre press. control. Loss of pressure.	
	 "----"	Transmission fault (➡ 50)
 lights up yellow.	 "----"	Sensor faulty or system fault (➡ 51)
 lights up yellow.	 Tyre pressure check failure!	Tyre pressure monitoring (RDC) failed (➡ 51)
 lights up yellow.	 RDC sensor battery weak.	Battery for tyre pressure sensor weak (➡ 51)
	 Drop sensor faulty.	Drop sensor defective (➡ 52)
	 Cannot start engine.	Motorcycle dropped (➡ 52)
 lights up yellow.	 Emergency call system restricted.	Emergency call function restricted (➡ 52)

36 STATUS INDICATORS

Indicator and warning lights	Display text	Meaning
 lights up yellow.	 Emergency call system error.	Emergency call function failed (▶▶▶▶ 52)
 lights up yellow.	 Side stand monitoring faulty.	Side stand monitoring is faulty (▶▶▶▶ 53)
 flashes.		ABS self-diagnosis not completed (▶▶▶▶ 53)
 lights up yellow.	 Limited ABS availability!	ABS fault (▶▶▶▶ 53)
 lights up.		
 lights up yellow.	 ABS Pro failure!	ABS Pro failed (▶▶▶▶ 54)
 lights up.		
 quick-flashes.		DTC intervention (▶▶▶▶ 54)
 slow-flashes.		DTC self-diagnosis not completed (▶▶▶▶ 54)
 lights up.	 Off!	DTC switched off (▶▶▶▶ 54)
	 Traction control deactivated.	
 lights up yellow.	 Traction control limited!	DTC restricted (▶▶▶▶ 55)
 lights up.		
 lights up yellow.	 Traction control failure!	DTC fault (▶▶▶▶ 55)

Indicator and warning lights	Display text	Meaning
 lights up.		DTC fault (►►► 55)
 lights up yellow.	 Spring strut adjustment faulty!	D-ESA fault (►►► 56)
	 shows green.	Hill Start Control active (►►► 56)
	 flashes yellow. HSC not available. Side stand extended.	Hill Start Control automatically deactivated (►►► 56)
	 is displayed. HSC not available. Engine not running.	Hill Start Control cannot be activated (►►► 57)
 lights up yellow.	 Brake temp. high!	The temperature of the brakes is too high (►►► 57)
 lights up yellow.	 Brake temp. critical!	Temperature of brake critical (►►► 57)
 lights up yellow.	 Cruise control has no function.	Adaptive cruise control failed (►►► 58)
	 Audio system too hot: Level 3	Temperature of audio system too high (►►► 58)
	 Audio system voltage high!	Voltage of audio system too high (►►► 59)

38 STATUS INDICATORS

Indicator and warning lights	Display text	Meaning
	 Tank reserve level reached.	Fuel down to reserve (→ 59)
	 The gear indicator flashes.	Gear not trained (→ 59)
 flashes green.		Hazard warning lights system
 flashes green.		is switched on (→ 59)
	 is displayed in white. Service due!	Service due (→ 60)
 lights up yellow.	 is displayed in yellow. Service overdue!	Service-due date has passed (→ 60)

Ambient temperature

The outside temperature is displayed in the status line of the TFT display.

When the vehicle is at a standstill, the heat of the electrical machine can falsify the ambient-temperature reading. If the heat of the electrical machine is affecting it too much, dashes are temporarily shown in place of the value.



There is a risk of black ice if the ambient temperature falls below the limit value of approx. 3 °C.

The first time the temperature drops below this value, the ambient-temperature reading and the ice crystal symbol flash in the status line of the TFT display.

Outside temperature warning



is displayed.

Possible cause:

	<p>The air temperature measured at the vehicle is lower than:</p>
<p>approx. 3 °C</p>	



WARNING

Risk of black ice forming even when temperature is above approx. 3 °C

Risk of accident

- Always take extra care when temperatures are low; remember that there is particular danger of black ice forming on bridges and where the road is in shade.

- Ride carefully and think well ahead.

Radio-operated key out of range

–with Keyless Ride^{OE}



lights up yellow.



Remote key not in range. Not possible to switch on ignition again.

Possible cause:

Communication between radio-operated key and engine electronics is disrupted.

- Check the battery in the radio-operated key.
 - with Keyless Ride^{OE}
- Replace the battery of the radio-operated key (➔ 69).
- Use the spare key to continue your journey.

40 STATUS INDICATORS

–with Keyless Ride^{OE}

- Battery of the radio-operated key is empty or loss of the radio-operated key (➡ 69).
- Remain calm if the Check Control dialogue appears on the display while you are riding. You can continue your journey, the engine will not switch off.
- Have the faulty radio-operated key replaced by an authorised BMW Motorrad retailer.

Keyless Ride failed

–with Keyless Ride^{OE}

 lights up yellow.

 Keyless Ride failure. Do not stop the engine. It may not be possible to restart the engine.

Possible cause:

The Keyless Ride control unit has diagnosed a communication fault.

- Do not switch off the engine. Proceed as directly as possible to an authorised workshop, preferably an authorised BMW Motorrad retailer.
 - » Engine start with Keyless Ride no longer possible.
 - » DWA can no longer be activated.

Replace the battery of the radio-operated key

–with Keyless Ride^{OE}

 lights up yellow.

 Remote key battery weak. Limited central locking function. Change battery.

Possible cause:

- The integral battery in the radio-operated key has lost a significant proportion of its original capacity. There is no assurance of how long the radio-operated key can remain operational.
- Replace the battery of the radio-operated key (➡ 69).

Voltage of the vehicle electrical system too low

 is displayed in yellow.

 Vehicle voltage low. Switch off unnecessary consumers.

The voltage of the vehicle electrical system is too low. If you continue to ride the motorcycle the on-board electronics will drain the battery.

Possible cause:

Consumers with high power consumption are in operation (such as heated body warmers), too many consumers are in operation at one time, or battery faulty.

- Switch off non-essential consumers or disconnect them from the vehicle's electrical system.
- If the fault persists or occurs without consumers connected, have the fault rectified as quickly as possible by a specialist workshop, preferably an authorised BMW Motorrad retailer.

Voltage of the vehicle electrical system critical



lights up yellow.



is displayed in yellow.



Vehicle voltage critical! Consumers were switched off. Check battery condition.



WARNING

Failure of the vehicle systems

Risk of accident

- Do not continue your journey.

The voltage of the vehicle electrical system is critical. If you continue to ride the motorcycle the on-board electronics will drain the battery.

Possible cause:

Consumers with high power consumption are in operation (such as heated body warmers), too many consumers are in operation at one time, or battery faulty.

- Switch off non-essential consumers or disconnect them from the vehicle's electrical system.
- If the fault persists or occurs without consumers connected, have the fault rectified as quickly as possible by a specialist workshop, preferably an authorised BMW Motorrad retailer.

Charging voltage critical



flashes yellow.

42 STATUS INDICATORS

 is displayed in yellow.

 Battery voltage critical! Accident risk. Stop driving.

WARNING

Failure of the vehicle systems

Risk of accident

- Do not continue your journey.

The battery is not being charged. If you continue to ride the motorcycle the on-board electronics will drain the battery.

Possible cause:

Alternator or alternator drive faulty.

- Have the fault rectified as quickly as possible by a specialist workshop, preferably an authorised BMW Motorrad dealer.

Bulb faulty

 lights up yellow.

 The faulty bulb is displayed:

 High beam faulty!

 Front left turn indicator faulty! or Front right turn indicator faulty!

 Low-beam headlight faulty!

 Front side light faulty!

–with daytime riding light^{OE}

 Daytime riding light faulty!◁

–with additional headlight^{OE}

 Left additional headlight faulty! or Right additional headlight faulty!◁

 Tail light faulty!

 Brake light faulty!

 Rear left turn indicator faulty! or Rear right turn indicator faulty!

 Number plate light faulty!

–Have it checked by a specialist workshop.

 flashes yellow.

 The faulty bulb is displayed:

 Active headlight faulty.

 **WARNING**

Vehicle overlooked in traffic due to failure of the lights on the vehicle

Safety risk

- Always replace a faulty bulb at the earliest possible opportunity. Consult a specialist workshop, preferably an authorised BMW Motorrad Retailer.

Possible cause:

Bulb faulty.

- Visually inspect to ascertain which bulb is faulty.
- Have LED light sources replaced as complete units; consult a specialist workshop, preferably an authorised BMW Motorrad retailer.

Light control failed

 lights up yellow.

 Light control failure! Have it checked by a specialist workshop.

 **WARNING**

Vehicle overlooked in traffic on account of failure of the vehicle lighting

Safety risk

- Have the fault rectified as quickly as possible by a specialist workshop, preferably an authorised BMW Motorrad retailer.

Possible cause:

Light control has diagnosed a communication fault.

- Have the fault rectified as quickly as possible by a specialist workshop, preferably an authorised BMW Motorrad retailer.

Anti-theft alarm battery weak
—with anti-theft alarm (DWA)^{OE}

 Alarm system batt. capacity weak. No restrictions. Make an appointment at a specialist workshop.

 This error message shows briefly only after the Pre-Ride-Check completes.

44 STATUS INDICATORS

Possible cause:

The integral battery in the anti-theft alarm has lost a significant proportion of its original capacity. There is no assurance of how long the anti-theft alarm can remain operational if the vehicle's battery is disconnected.

- Seek the advice of a specialist workshop, preferably an authorised BMW Motorrad dealer.

Anti-theft alarm battery flat

–with anti-theft alarm (DWA)^{OE}

 Alarm system battery empty. No independent alarm. Make an appointment at a specialist workshop.

 This error message shows briefly only after the Pre-Ride-Check completes.

Possible cause:

The integral battery in the anti-theft alarm has lost its entire original capacity. There is no assurance that the anti-theft alarm will be operational if the vehicle's battery is disconnected.

- Seek the advice of a specialist workshop, preferably an authorised BMW Motorrad dealer.

DWA failed

–with anti-theft alarm (DWA)^{OE}

 Alarm system failure
Have it checked by a specialist workshop.

Possible cause:

The DWA control unit has diagnosed a communication fault.

- Consult a specialist workshop, preferably an authorised BMW Motorrad retailer.
 - » DWA can no longer be activated or deactivated.
 - » False alarm possible.

Electronic oil-level check

 The electronic oil-level check assesses the oil level in the engine as OK or Low!

The preconditions for the electronic oil-level check are as follows:

- Engine idling for at least 10 seconds.
- Engine is at operating temperature.
- No brake applied.
- Vehicle is standing upright on a smooth, level surface.
- Side stand is retracted or vehicle propped on its centre stand.

If measurement is incomplete or if these conditions are not met, the oil level cannot be

judged by the system. Dashes (---) appear on the display instead of a reading.

Engine-oil level too low



lights up yellow.



Engine oil level
Check engine oil level.

Possible cause:

The electronic oil-level sensor has registered an excessively low oil level. Check the engine oil level using the oil dipstick at the next refuelling stop:

- Check the engine oil level (▣▣▣▶ 182).

If the oil level is too low:

- Top up the engine oil (▣▣▣▶ 183).

Coolant temperature too high



lights up yellow.



Coolant temperature too high! Check coolant level. Continue driving in part. load to cool down.



ATTENTION

Riding with overheated engine

Engine damage

- Compliance with the information set out below is essential.

Possible cause:

The coolant level is too low.

- Check the coolant level (▣▣▣▶ 189).

If the coolant level is too low:

- Have the coolant topped up and the coolant system checked by a specialist workshop, preferably by an authorised BMW Motorrad retailer.

Possible cause:

The coolant temperature is too high.

- If possible, ride in the part-load range to cool down the engine.
- In traffic jams, switch off the engine, but leave the ignition switched on so that the radiator fan continues to operate.
- If the coolant temperature is frequently too high, have the fault rectified as soon as possible by a specialist workshop, preferably an authorised BMW Motorrad dealer.

46 STATUS INDICATORS

Drive malfunction



lights up.



Engine! Have it checked by a specialist workshop.

Possible cause:

The engine control unit has diagnosed a fault which affects the pollutant emissions.

- Have the fault rectified by a specialist workshop, preferably an authorised BMW Motorrad dealer.
- » You can continue riding; pollutant emissions are higher than the threshold values.

Serious drive malfunction



flashes red.



flashes.



Serious fault in the engine control! Riding at mod. speed pos. Damage possible. Have checked by workshop.

Possible cause:

The engine control unit has diagnosed a fault that can lead to damage to the exhaust system.

- Have the fault rectified as quickly as possible by a specialist workshop, preferably an

authorised BMW Motorrad retailer.

» It is possible to continue to ride but not recommended.

Engine control failed



lights up yellow.



lights up.



No communication with engine control. Multiple sys. affected. Ride carefully to the next specialist workshop.

Possible cause:

Communication with the engine control unit has failed.

- Have the fault rectified as quickly as possible by a specialist workshop, preferably an authorised BMW Motorrad retailer.

Engine in emergency-operation mode



lights up yellow.



Fault in the engine control. Onward journey possible. Ride carefully to next specialist workshop.

**WARNING****Unusual ride characteristics when engine running in emergency-operation mode**

Risk of accident

- Avoid accelerating sharply and overtaking.

Possible cause:

The engine control unit has diagnosed a fault. In exceptional cases, the engine stops and refuses to start. Otherwise, the engine runs in emergency operating mode.

- You can continue to ride, but bear in mind that the usual engine performance might not be available.
- Have the fault rectified as quickly as possible by a specialist workshop, preferably an authorised BMW Motorrad retailer.

Serious fault in engine control

flashes red.



Serious fault in the engine control! Riding at mod. speed pos. Damage possible. Have checked by workshop.

**WARNING****Engine damage when running in emergency-operation mode**

Risk of accident

- Ride slowly, avoid accelerating sharply and overtaking.
- If possible, have the vehicle picked up and have the fault rectified by a specialist workshop, preferably an authorised BMW Motorrad Retailer.

Possible cause:

The engine control unit has diagnosed a fault which may cause severe secondary faults. The engine is in emergency-operation mode.

- It is possible to continue to ride but not recommended.
- Avoid high load and rpm ranges if possible.
- Have the fault rectified as quickly as possible by a specialist workshop, preferably an authorised BMW Motorrad retailer.

48 STATUS INDICATORS

Tyre pressure

In addition to the MY VEHICLE menu screen and the Check Control messages, there is also the TYRE PRESSURE screen for showing the tyre pressures:

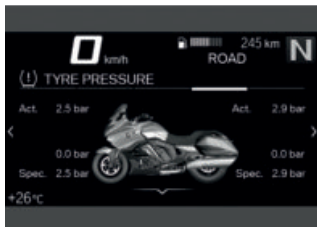

The values on the left are for the front wheel; those on the right are for the rear wheel. Actual and specified tyre pressures and the difference between them are displayed for each wheel. Immediately after the ignition is switched on, only dashes are displayed. The sensors do not start transmitting tyre pressure signals until the first time the vehicle accelerates to more than the minimum speed stated below:



RDC sensor is not active

min 30 km/h (The RDC sensor does not transmit its signal to the vehicle until a certain minimum speed has been reached.)



The tyre pressures are shown in the TFT display as temperature compensated and always refer to the following tyre air temperature:

20 °C



If the tyre symbol appears as well, showing yellow or red, this is a warning. The pressure difference is highlighted with an exclamation point in the same colour.



If the value in question is close to the limit of the permissible tolerance range, the reading is accompanied by the 'General' warning light showing yellow.



The 'General' warning light flashes red if the tyre pressure registered by the sensor is outside the permissible tolerance range.

For further information about BMW Motorrad RDC, see the section entitled "Engineering details" (▶▶ 172).

Tyre pressure close to limit of permitted tolerance

 lights up yellow.

 is displayed in yellow.

 Tyre pressure does not match setpoint
Check tyre pressure.

Possible cause:

Measured tyre pressure is close to the limit of permitted tolerance.

- Correct tyre pressure.
- Before adjusting tyre pressure, read the information on temperature compensation and adjusting pressure in the section entitled "Engineering details" (▶▶ 172).

- » Find the correct tyre pressures in the following places:
- Back cover of the rider's manual
 - Instrument cluster in the TYRE PRESSURE view
 - Sign on left fork leg

Tyre pressure outside permitted tolerance

 flashes red.

 is displayed in yellow.

 Tyre pressure does not match setpoint
Stop immediately! Check tyre pressure.

 Tyre press. control.
Loss of pressure.
Stop immediately! Check tyre pressure.

WARNING

Tyre pressure outside the permitted tolerance.

Risk of accident, degradation of the vehicle's driving characteristics.

- Adapt your style of riding accordingly.

Possible cause:

Measured tyre pressure is outside permitted tolerance.

- Check the tyre for damage and to ascertain whether the vehicle can be ridden with the tyre in its present condition. If the vehicle can be ridden with the tyre in its present condition:

50 STATUS INDICATORS

- Correct the tyre pressure at the earliest possible opportunity.
- Before adjusting tyre pressure, read the information on temperature compensation and adjusting pressure in the section entitled "Engineering details" (▮▮▮▮ 172).

» Find the correct tyre pressures in the following places:

- Back cover of the rider's manual
- Instrument cluster in the TYRE PRESSURE view
- Sign on left fork leg

- Have the tyre checked for damage by a specialist workshop, preferably an authorised BMW Motorrad retailer.

If you are unsure whether the vehicle can be ridden with the tyre in its present condition:

- Do not continue your journey.
- Notify the breakdown service.

Transmission fault



"----"

Possible cause:

The vehicle has not reached the minimum speed (▮▮▮▮ 172).



RDC sensor is not active

min 30 km/h (The RDC sensor does not transmit its signal to the vehicle until a certain minimum speed has been reached.)

- Increase speed above this threshold and observe the RDC readings. Assume that a permanent fault has not occurred unless the 'General' warning light comes on to accompany the symptoms. Under these circumstances:
- Have the fault rectified by a specialist workshop, preferably an authorised BMW Motorrad retailer.

Possible cause:

Wireless communication with the RDC sensors has been disrupted. Possible causes include radio-communication systems operating in the vicinity and interfering with the link between the RDC control unit and the sensors.

- Move to another location and observe the RDC readings. Assume that a permanent fault has not occurred unless the 'General' warning light comes on to accompany the

symptoms. Under these circumstances:

- Have the fault rectified by a specialist workshop, preferably an authorised BMW Motorrad retailer.

Sensor faulty or system fault



lights up yellow.



"----"

Possible cause:

Motorcycle is fitted with wheels not equipped with RDC sensors.

- Fit wheels and tyres equipped with RDC sensors.

Possible cause:

One or two RDC sensors have failed or a system fault has occurred.

- Have the fault rectified by a specialist workshop, preferably an authorised BMW Motorrad retailer.

Tyre pressure monitoring (RDC) failed



lights up yellow.



Tyre pressure check failure! Function limited. Have it checked by a specialist workshop.

Possible cause:

The tyre pressure monitoring (RDC) control unit has diagnosed a communication fault.

- Consult a specialist workshop, preferably an authorised BMW Motorrad retailer.
- » Tyre pressure warnings not available.

Battery for tyre pressure sensor weak



lights up yellow.



RDC sensor battery weak. Function limited. Have it checked by a specialist workshop.



This error message shows briefly only after the Pre-Ride-Check completes.

Possible cause:

The integral battery in the tyre-pressure sensor has lost a significant proportion of its original capacity. There is no assurance of how long the tyre pressure monitoring system can remain operational.

- Consult a specialist workshop, preferably an authorised BMW Motorrad retailer.

52 STATUS INDICATORS

Drop sensor defective

 Drop sensor faulty. Have it checked by a specialist workshop.

Possible cause:

The drop sensor is not available.

- Consult a specialist workshop, preferably an authorised BMW Motorrad retailer.

Motorcycle dropped

 Cannot start engine. Stand motorcycle upright. Switch ignition on/off. Start the engine.

Possible cause:

The drop sensor has detected a drop and has cut out the engine.

- Hold the vehicle upright and check it for damage.
- Switch the ignition off and then on again or switch the kill switch on and then off again.

Emergency call function restricted

–with intelligent emergency call^{OE}

 lights up yellow.

 Emergency call system restricted. If this occurs again, have the vehicle checked by a specialist workshop.

Possible cause:

The emergency call cannot be made automatically or cannot be made via BMW.

- Consult the information on operating the intelligent emergency call on page (📖 71)ff.
- Consult a specialist workshop, preferably an authorised BMW Motorrad retailer.

Emergency call function failed

–with intelligent emergency call^{OE}

 lights up yellow.

 Emergency call system error. Make an appointment at a specialist workshop.

Possible cause:

The control unit of the emergency call system has diagnosed a fault. The emergency call function has failed.

- Bear in mind that an emergency call cannot be made.
- Consult a specialist workshop, preferably an authorised BMW Motorrad retailer.

Side stand monitoring is faulty



lights up yellow.



Side stand monitoring faulty. Onward journey possible. Engine stop. when stationary! Have checked by workshop.

Possible cause:

The side-stand switch or its wiring are damaged. The engine is shut down when speed drops below 5 km/h. You cannot resume your journey.

- Consult a specialist workshop, preferably an authorised BMW Motorrad retailer.

ABS self-diagnosis not completed



flashes.

Possible cause:



ABS self-diagnosis not completed

The ABS function is not available, because self-diagnosis did not complete. (The motorcycle has to reach a defined minimum speed with the engine running for the wheel sensors to be checked: min 5 km/h)

- Pull away slowly. Bear in mind that the ABS function is not available until self-diagnosis has completed.

ABS fault



lights up yellow.



lights up.



Limited ABS availability! Onward journey possible. Ride carefully to next specialist workshop.

Possible cause:

The ABS control unit has detected a fault. The partial integral brake has failed. The ABS function is available, subject to restrictions.

- You can continue to ride. Bear in mind the more detailed information on certain situations that can lead to an ABS fault message (166).
- Have the fault rectified as quickly as possible by a specialist workshop, preferably an authorised BMW Motorrad retailer.

54 STATUS INDICATORS

ABS Pro failed

 lights up yellow.

 lights up.

 ABS Pro failure! Onward journey possible. Ride carefully to next specialist workshop.

Possible cause:

The ABS Pro control unit has detected a fault. The ABS Pro function is not available. The ABS function is still available. ABS provides support only for braking in straight-ahead driving.

- You can continue to ride. Bear in mind the more detailed information on certain situations that can lead to an ABS Pro fault message (➔ 166).
- Have the fault rectified as quickly as possible by a specialist workshop, preferably an authorised BMW Motorrad retailer.

DTC intervention

 quick-flashes.

The DTC has detected a degree of instability at the rear wheel and has intervened to

reduce torque. The indicator and warning light flashes for longer than DTC intervention lasts. This affords the rider visual feedback on control intervention even after the critical situation has been dealt with.

DTC self-diagnosis not completed

 slow-flashes.

Possible cause:

 DTC self-diagnosis not completed

The DTC function is not available, because self-diagnosis did not complete. (The motorcycle has to reach a defined minimum speed with the engine running for the wheel sensors to be checked: min 5 km/h)

- Pull away slowly. Bear in mind that the DTC function is not available until self-diagnosis has completed.

DTC switched off

 lights up.

 Off!

 Traction control deactivated.

Possible cause:

The rider has switched off the DTC system.

- Switch the DTC function off and on (➔ 82).

DTC restricted

 lights up yellow.

 lights up.

 Traction control limited! Onward journey possible.

Ride carefully to next specialist workshop.

Possible cause:

The DTC control unit has detected a fault.



ATTENTION

Damaged components

Damage to sensors, for example, which causes malfunctions

- Do not transport any objects underneath the driver or passenger seat.
- Secure the toolkit.

- Do not damage the angular rate sensor.

- Bear in mind that the DTC function and dynamic engine brake control are restricted.

- You can continue to ride.

Bear in mind the more detailed information on situations that can lead to a DTC fault (➔ 168).

- Have the fault rectified as quickly as possible by a specialist workshop, preferably an authorised BMW Motorrad retailer.

DTC fault

 lights up yellow.

 lights up.

 Traction control failure! Onward journey possible.

Ride carefully to next specialist workshop.

Possible cause:

The DTC control unit has detected a fault.

56 STATUS INDICATORS



ATTENTION

Damaged components

Damage to sensors, for example, which causes malfunctions

- Do not transport any objects underneath the driver or passenger seat.
 - Secure the toolkit.
- Do not damage the angular rate sensor.
 - Bear in mind that the DTC function and dynamic engine brake control are not available.
 - You can continue to ride. Bear in mind the more detailed information on situations that can lead to a DTC fault (► 168).
 - Have the fault rectified as quickly as possible by a specialist workshop, preferably an authorised BMW Motorrad retailer.

D-ESA fault



lights up yellow.



Spring strut adjustment faulty! Onward journey possible. Ride carefully to next specialist workshop.

Possible cause:

The D-ESA control unit has detected a fault. In this condition, the motorcycle has too much damping and is uncomfortable to drive, especially on roads in poor condition.

- Have the fault rectified as quickly as possible by a specialist workshop, preferably an authorised BMW Motorrad dealer.

Hill Start Control active



shows green.

Possible cause:

Hill Start Control (► 174) has been activated by the rider.

- Switch off Hill Start Control.
- Operate Hill Start Control Pro (► 88).

Hill Start Control automatically deactivated



flashes yellow.

HSC not available. Side stand extended.

Possible cause:

Hill Start Control has been automatically deactivated.

- Retract the side stand.
- » Hill Start Control is operational only with the side stand retracted.
- Start the engine.

- » Hill Start Control is operational only while the engine is running.

Hill Start Control cannot be activated



is displayed.

HSC not available. Engine not running.

Possible cause:

Hill Start Control has been automatically deactivated.

- Retract the side stand.
- » Hill Start Control is operational only with the side stand retracted.
- Start the engine.
- » Hill Start Control is operational only while the engine is running.

The temperature of the brakes is too high



lights up yellow.



Brake temp. high! Continue riding carefully to cool down. Avoid dynamic riding.



DANGER

Riding with overheated brakes

Risk of accident due to failure of brakes

- Adapt your riding style accordingly.
- Avoid frequent braking by using the engine brake.



WARNING

Failure to observe service intervals

Risk of accident

- Observe the valid service intervals for brakes.

Temperature of brake critical



lights up yellow.



Brake temp. critical! Continue riding carefully to cool down. Avoid dynamic riding.

58 STATUS INDICATORS



DANGER

Riding with overheated brakes

Risk of accident due to failure of brakes

- Adapt your riding style accordingly.
- Avoid frequent braking by using the engine brake.



WARNING

Failure to observe service intervals

Risk of accident

- Observe the valid service intervals for brakes.

Possible cause:

The temperature of the brake is in a critical range.

- By adopting a moderate riding style you can continue to ride until the warning light goes out.

Adaptive cruise control failed



lights up yellow.



Cruise control has no function. Onward journey possible. Inspection at workshop required.

Possible cause:

The control unit has detected a fault.

- Bear in mind that cruise control is not available.
- You can continue to ride.

Have the fault rectified as quickly as possible by a specialist workshop, preferably an authorised BMW Motorrad retailer.

Temperature of audio system too high



Audio system too hot: Level 3 Audio system has been switched off.

The temperature of the control unit for the audio system is too high. The audio system is powered down.

Possible cause:

The audio system control unit has diagnosed an excessively high temperature.

- Protect the motorcycle from the direct rays of the sun.
- If the fault persists, have it rectified as quickly as possible by a specialist workshop, preferably an authorised BMW Motorrad retailer.

Voltage of audio system too high

 Audio system voltage high! Audio system has been muted.

Possible cause:

The audio system control unit has diagnosed an excessively high voltage.

- Have the fault rectified as quickly as possible by a specialist workshop, preferably an authorised BMW Motorrad retailer.

Fuel down to reserve

 Tank reserve level reached. Ride to the next filling station.

WARNING

Irregular engine operation or engine shutdown due to lack of fuel

Risk of accident, damage to catalytic converter

- Do not run the fuel tank dry.

Possible cause:

The fuel tank contains no more than the reserve quantity of fuel.



Reserve fuel

approx. 4 l

- Refuel (➡ 156).

Gear not trained

–with shift assistant Pro^{OE}

 The gear indicator flashes.

Possible cause:

–with shift assistant Pro^{OE}

The gearbox sensor is not fully trained.

- Select neutral N and allow the engine to idle for at least 10 seconds to teach the neutral position.
- Use clutch control to engage each gear in turn and ride for a minimum of 10 seconds in each gear.
 - » The gear indicator stops flashing when the gearbox sensor has been trained successfully.
- When the gearbox sensor has been taught successfully, Gear Shift Assistant Pro works as described (➡ 173).
- If teaching is not successful, have the fault rectified by a specialist workshop, preferably an authorised BMW Motorrad retailer.

Hazard warning lights system is switched on

 flashes green.

60 STATUS INDICATORS

 flashes green.

Possible cause:

The driver has switched on the hazard warning lights system.

- Hazard warning lights ( 77).

Service-due indicator

 If service is overdue, the due date or the odometer reading at which service was due is accompanied by the 'General' warning light showing yellow.

If the service is overdue, a yellow CC message is displayed. Exclamation marks also draw your attention to the displays for service, service appointment and countdown distance in the MY VEHICLE and SERVICE REQUIREMENTS menu screens.

 If the service-due indicator appears more than a month before the service date, the current date has to be corrected. This situation can occur if the battery was disconnected.

Service due

 is displayed in white.

Service due! Have service performed by a specialist workshop.

Possible cause:

Service is due, because of either distance covered or time expired.

- Have your motorcycle serviced regularly by a specialist workshop, preferably an authorised BMW Motorrad retailer.
- » The vehicle remains operationally reliable and road-worthy.
- » The vehicle retains its value.

Service-due date has passed

 lights up yellow.

 is displayed in yellow.

Service overdue! Have service performed by a specialist workshop.

Possible cause:

Service is overdue because of the driving performance or the date.

- Have your motorcycle serviced regularly by a specialist workshop, preferably an authorised BMW Motorrad retailer.
- » The vehicle remains operationally reliable and road-worthy.
- » The vehicle retains its value.

OPERATION

04

IGNITION SWITCH/STEERING LOCK	64
IGNITION WITH KEYLESS RIDE	65
EMERGENCY-OFF SWITCH (KILL SWITCH)	71
INTELLIGENT EMERGENCY CALL	71
LIGHTING	74
ANTI-THEFT ALARM (DWA)	79
DYNAMIC TRACTION CONTROL (DTC)	82
ELECTRONIC SUSPENSION ADJUSTMENT (D-ESA)	82
RIDING MODE	83
ADAPTIVE CRUISE CONTROL	84
HILL START CONTROL	87
REVERSER	89
CENTRAL LOCKING SYSTEM	90
HEATING	91
SLIPSTREAM DEFLECTOR	93
SEAT	94
CASES	94
STORAGE COMPARTMENTS	96

64 OPERATION

IGNITION SWITCH/STEERING LOCK

Keys

You receive 2 vehicle keys. If a key is lost or mislaid, consult the notes on the electronic immobiliser (EWS) (▮▮▮ 68).

The following locks are operated with the same key:

- Ignition switch/steering lock
- Cases locks
- Storage-compartment lock
- Fuel filler cap
- Seat lock

Engaging steering lock



ATTENTION

Incorrect handlebar angle upon parking on the side stand

Component damage caused by the vehicle falling over

- On level ground, always turn the handlebars to the left to set the steering lock.
- Turn the handlebars all the way to the left.

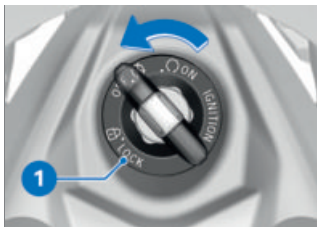

- Turn the ignition key to position **1**, while moving the handlebars slightly.
 - » Ignition, lights and all function circuits switched off.
 - » Steering lock engaged.
 - » Vehicle key can be removed.

Switching on ignition

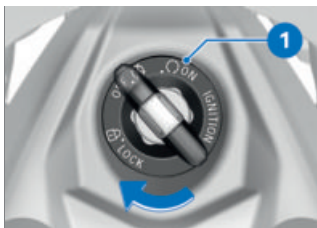

- Turn the ignition key to position **1**.
 - » Side lights and all function circuits switched on.
 - » Pre-Ride-Check is performed. (▮▮▮ 148)
 - » ABS self-diagnosis is in progress. (▮▮▮ 148)
 - » DTC self-diagnosis is in progress. (▮▮▮ 149)

Switching off ignition



- Turn the ignition key to position **1**.
- » When the ignition is switched off, the instrument cluster remains switched on for a short time and displays any existing fault messages.
- » Windscreen moves to the bottom end position.
- » Handlebars not locked.
- » Electrically powered accessories remain operational for a limited period of time.
- » The battery can be recharged via the socket in the cockpit.
- » Vehicle key can be removed.

–with daytime riding light^{OE}

- The daytime riding light goes out soon after the ignition is switched off.◁

–with additional headlight^{OE}

- The LED auxiliary headlights go out soon after the ignition is switched off.◁

IGNITION WITH KEY-LESS RIDE

Keys

–with Keyless Ride^{OE}

 The telltale light for the radio-operated key flashes while the search for the radio-operated key is in progress. The light goes out as soon as the radio-operated key or the emergency key is found. The light goes out briefly if the search times out without the radio-operated key or the emergency key being found.

You receive one radio-operated key and one spare key. If a key is lost or mislaid, consult the notes on the electronic immobiliser (EWS) (▶ 68).

Ignition, fuel filler cap, central locking system and anti-theft device all work with the radio-operated key. Seat lock, storage compartments and cases can be locked and unlocked manually.

 The vehicle cannot be started and the central locking system cannot be locked or unlocked if the radio control key is not within range (e.g. key inside a case). If the key is out of range, the ignition is switched off after

66 OPERATION

approximately 1.5 minutes, but the central locking system is **not** locked.

It is advisable to keep the radio-operated key on your person (e.g. in a jacket pocket) and to have the spare key with you as an alternative.



Range of the Keyless Ride radio-operated key

approx. 1 m

Engaging steering lock

—with Keyless Ride^{OE}

Requirement

Handlebars are turned to the left. Radio-operated key is within range.



ATTENTION

Incorrect handlebar angle upon parking on the side stand

Component damage caused by the vehicle falling over

- On level ground, always turn the handlebars to the left to set the steering lock.

- Press and hold down button **1**.
 - » The steering lock engages with an audible click.
 - » Ignition, lights and all function circuits switched off.
- Short-press button **1** to disengage the steering lock.

Switching on ignition

—with Keyless Ride^{OE}

Requirement

Radio-operated key is within range.



- There are **two** ways of activating the ignition.

Version 1:

- Short-press button **1**.
 - » Side lights and all function circuits are switched on.
 - with daytime riding light^{OE}
 - » Daytime riding light is switched on.◁
 - with additional headlight^{OE}
 - » LED auxiliary headlights are switched on.◁
 - » Pre-Ride-Check is performed. (▮▮▮ 148)
 - » ABS self-diagnosis is in progress. (▮▮▮ 148)
 - » DTC self-diagnosis is in progress. (▮▮▮ 149)

Version 2:

- Steering lock is engaged; press and hold down button **1**.
 - » The steering lock disengages.
 - » Side lights and all function circuits switched on.
 - with daytime riding light^{OE}
 - » Daytime riding light is switched on.◁

- with additional headlight^{OE}
 - » LED auxiliary headlights are switched on.◁
 - » Pre-Ride-Check is performed. (▮▮▮ 148)
 - » ABS self-diagnosis is in progress. (▮▮▮ 148)
 - » DTC self-diagnosis is in progress. (▮▮▮ 149)

Switching off ignition

- with Keyless Ride^{OE}

Requirement

Radio-operated key is within range.



- There are **two** ways of deactivating the ignition.

Version 1:

- Short-press button **1**.
 - » When the ignition is switched off, the instrument cluster remains switched on for a short time and displays any existing fault messages.
 - » Windscreen moves to the bottom end position.

68 OPERATION

- » Ground light comes on for a short time.
- » Handlebars not locked.
- » Electrically powered accessories remain operational for a limited period of time.
- » The battery can be recharged via the socket in the cockpit.

Version 2:

- Turn the handlebars all the way to the left.
- Press and hold down button **1**.
- » When the ignition is switched off, the instrument cluster remains switched on for a short time and displays any existing fault messages.
- » Windscreen moves to the bottom end position.
- » Ground light comes on for a short time.
- » Steering lock engaged.
- » Electrically powered accessories remain operational for a limited period of time.
- » The battery can be recharged via the socket in the cockpit.

Electronic immobiliser (EWS)

The on-board electronics access the data saved in the vehicle key via a ring aerial in the R/C ignition lock. The ignition is not enabled for starting until the engine control unit has recognised the ignition

key as "authorised" for your motorcycle.



Another vehicle key attached to the same ring as the vehicle key used to start the engine could "irritate" the electronics, in which case the enabling signal for starting is not issued. The warning with the key symbol appears in the multifunction display. Always keep other vehicle keys separate from the vehicle key used to start the engine.

If you lose a key, you can have it barred by your authorised BMW Motorrad retailer. If you wish to do this, you will need to bring all other keys for the motorcycle with you.

The engine cannot be started by a barred ignition key, but an ignition key that has been barred can subsequently be reactivated.

You can obtain spare keys only through an authorised BMW Motorrad retailer. The ignition keys are part of an integrated security system, so the retailer is under an obligation to check the legitimacy of all applications for replacement/extra keys.

Battery of the radio-operated key is empty or loss of the radio-operated key

—with Keyless Ride^{OE}

- Make sure the ground is level and firm and place the motorcycle on its stand.
- If a key is lost or mislaid, consult the information on the electronic immobiliser (EWS) (▣▣▣ 68).
- If you happen to lose or mislay the radio-operated key while on a journey, you can use the spare key to start the vehicle.
- If the battery of the radio-operated key is flat, the motorcycle can be started by touching the tank cover with the radio-operated key.

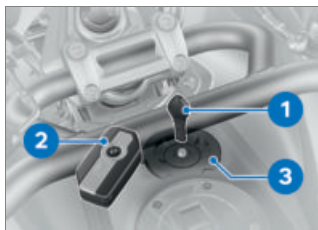

- Hold spare key **1** or radio-operated key with empty battery **2** at the tank cover above radio aerial **3**.



Time during which the engine has to be started. The unlocking procedure has to be repeated if this time is allowed to expire.

30 s

- » Pre-Ride-Check is performed. (▣▣▣ 148)
- » Key has been recognised.
- Start the engine (▣▣▣ 147).

Replacing battery of radio-operated key

—with Keyless Ride^{OE}

If the radio-operated key does not react when you short-press or long-press a button:

- Battery of the radio-operated key is not at full capacity.



Remote key battery weak. Limited central locking function. Change battery.

70 OPERATION

DANGER

Swallowing a battery

Risk of injury or death

- An ignition key contains a button cell as its battery. Batteries or button cells, if swallowed, can cause serious or fatal injury within two hours, for example resulting from internal burns or caustic action.
- Keep ignition keys and batteries out of reach of children.
- If there is any suspicion that a battery or button cell has been swallowed or is inside a part of the body, seek medical assistance immediately.

- Change the battery.

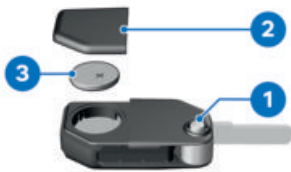

- Press button **1**.
 - » Key bit flips out.
- Push battery cover **2** up.
- Remove battery **3**.

- Dispose of the old battery in accordance with all applicable laws and regulations; do not attempt to dispose of batteries as domestic waste.

ATTENTION

Unsuitable or incorrectly inserted batteries

Component damage

- Use a battery compliant with the manufacturer's specifications.
 - When inserting the battery, always make sure polarity is correct.
- Insert the new battery with the positive terminal up.



Battery type

For Keyless Ride radio-operated key

CR 2032

- Install battery cover **2**.
 - » Indicator light in the instrument cluster flashes.
 - » The radio-operated key is again ready for use.

EMERGENCY-OFF SWITCH (KILL SWITCH)



- 1 Emergency-off switch (kill switch)



WARNING

Operation of the kill switch while riding

Risk of fall due to rear wheel locking

- Do not operate the kill switch when riding.

The emergency off switch is a kill switch for switching off the engine quickly and easily.



- A Engine switched off
B Normal operating position (run)

INTELLIGENT EMERGENCY CALL

–with intelligent emergency call^{OE}

Emergency call via BMW

Only press the SOS button in an emergency or when help is necessary.

Even if an emergency call using BMW is not possible, the system may make an emergency call to a public emergency call number. This depends on the respective mobile phone network and the national regulations.

The emergency call is not able to be ensured because of technical reasons due to unfavourable conditions, e.g. in areas where there is no mobile phone reception.

72 OPERATION

Language for emergency call

Each vehicle has a language assigned to it depending on the market for which it is intended. The BMW Call Center answers in this language.

 A changeover of the language for the emergency call can only be performed by the BMW Motorrad partner. The language assigned to the vehicle varies from the selectable language the driver can choose as the display language in the multifunction display.

Manual emergency call Requirement

An emergency call has occurred. The vehicle is at a standstill. The ignition is switched on.

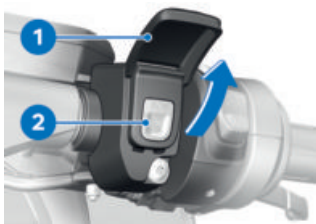

- Open cover **1**.
- Short-press SOS button **2**.

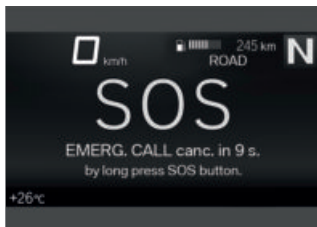

The time until transmission of the emergency call is displayed. During this time, the emergency call can be cancelled by pressing and holding the SOS button.

- Operate the emergency-off switch to stop the engine.
 - Remove helmet.
- » After expiry of the timer, a voice contact to the BMW Call Center is established.

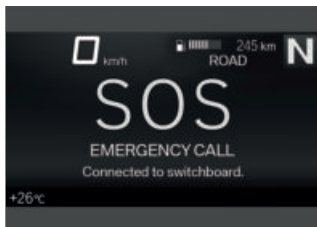

The connection was established.



- Provide information to the emergency services using the microphone **3** and speaker **4**.

Automatic emergency call

The intelligent emergency call is active after the ignition is switched on and reacts if a fall or crash occurs.

Emergency call in the event of a light fall

- A light fall or a crash was detected.
- » An acoustic signal is sounded.

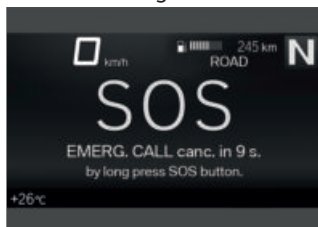

The time until transmission of the emergency call is displayed. During this time, the emergency call can be cancelled by

pressing and holding the SOS button.

- If possible, remove helmet and stop engine.
- » After expiry of the timer, a voice contact to the BMW Call Center is established.

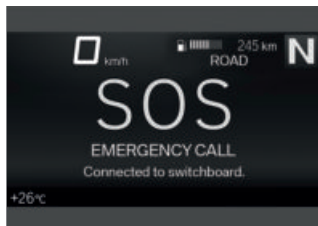

The connection was established.

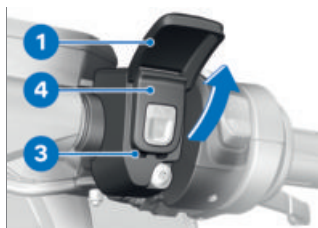

- Open cover **1**.
- Provide information to the emergency services using the microphone **3** and speaker **4**.

Emergency call in the event of a severe fall

- A severe fall or a crash is detected.

74 OPERATION

» The emergency call is placed automatically without delay.

LIGHTING

Side light

The side lights switch on automatically when the ignition is switched on.

 The side lights place a strain on the battery. Do not switch the ignition on for longer than absolutely necessary.

Switching on low-beam headlight

- Switch on the ignition (▮▮▮▮ 64).
- Start the engine (▮▮▮▮ 147).



- Alternatively: With the ignition switched on, pull switch **1**.

 The low-beam headlight places a strain on the battery. When the engine is not running, do not switch on the low-beam headlight for longer than absolutely necessary.

High-beam headlight and headlight flasher

- Switch on the ignition (▮▮▮▮ 64).



- Push switch **1** forward to switch on the high-beam headlight.
- Pull switch **1** back to operate the headlight flasher.

 The high-beam headlight can also be switched on when the engine is not running.

 The high-beam headlight places a strain on the battery. When the engine is not running, do not switch on the high-beam headlight for longer than absolutely necessary.

Headlight courtesy delay feature

- Switch off the ignition (▮▮▮▮ 65).



- Immediately after switching off the ignition, pull switch **1** back and hold it in that position until the headlight courtesy delay feature comes on.
 - » The vehicle's lights come on for one minute and then switch off automatically.
 - This can be used to light up the path to the house door after the vehicle has been parked, for example.

Ground lighting

–with floor lighting^{OE}

The ground light comes on for a short time after the ignition is switched off or after the anti-theft alarm system is deactivated with the radio-operated key.

Parking lights

- Switch off the ignition (▮▮▮▮▶ 65).



- Immediately after switching off the ignition, push button **1** to the left and hold it in that position until the parking lights come on.
- Switch the ignition on and off again to switch off the parking lights.

Auxiliary headlights

–with additional headlight^{OE}

Requirement

The low-beam headlight must be switched on.

 The auxiliary headlights have approval as fog lights and their use is permissible in bad weather conditions only. Always comply with the road traffic regulations in force in the country in which the vehicle is used.

76 OPERATION



- Press button **1** to switch on the auxiliary headlights.



lights up.

- Press button **1** again to switch off the auxiliary headlights.

Manual daytime riding light

—with daytime riding light^{OE}

Requirement

Automatic daytime riding light is switched off.



WARNING

Switching on the daytime riding light in the dark.

Risk of accident

- Do not use the daytime riding light in the dark.



By comparison with the low-beam headlight, the daytime running light makes the vehicle more visible to on-coming traffic. This improves daytime visibility.

- Start the engine (→ 147).
- Navigate to Settings, Vehicle settings, Lights and switch off the Auto. daytime light function.



- Press button **1** to switch on the daytime riding light.



lights up.

- » The low-beam headlight, the front side lights and the auxiliary headlight are switched off.
- In the dark or in tunnels: Press button **1** again to switch off the daytime riding light and switch on the low-beam headlight and the front side lights. The auxiliary headlight is also switched on again.



The daytime riding light is switched off after approximately 2 seconds and the high-beam headlight, low-beam headlight, front side lights and

the additional headlight, as appropriate, are switched on if the high beam is switched on while the daytime riding light is on.

If the high beam headlight is switched off again, the daytime running light is not automatically reactivated, but must be switched on again if required.

Automatic daytime riding light –with daytime riding light^{OE}



WARNING

The automatic daytime riding light is not a substitute for the rider's personal judgement of the light conditions

Risk of accident

- Switch off the automatic daytime riding light in poor light conditions.



WARNING

Switching on the daytime riding light in the dark.

Risk of accident

- Do not use the daytime riding light in the dark.



By comparison with the low-beam headlight, the daytime running light makes

the vehicle more visible to oncoming traffic. This improves daytime visibility.



The changeover between daytime riding light and low-beam headlight including front side lights can be effected automatically.

- Switch on the ignition (▣▣▣ 64).
- Call up the **Settings** and then select **Vehicle settings**.
- Select **Lights** and switch on **Auto. daytime light**.
 is displayed.

» If the ambient brightness decreases below a certain value (e.g. in a tunnel) while the daytime riding light function is active, the low-beam headlight is automatically switched on. When sufficient ambient brightness is detected, the daytime riding light is switched back on.



lights up.

Hazard warning lights

- Switch on the ignition (▣▣▣ 64).



The hazard warning flashers place a strain on the battery. Do not use the hazard warning flashers for longer than absolutely necessary.

ANTI-THEFT ALARM (DWA)

–with anti-theft alarm (DWA)^{OE}

Activation

- Switch on the ignition (▮▮▮▮ 64).
- Adapt DWA (▮▮▮▮ 81).
- Switch off the ignition (▮▮▮▮ 65).

» If the anti-theft alarm system (DWA) is activated, the alarm system is armed automatically when you switch the ignition off.

» Activation takes approximately 30 seconds to complete.

» Turn indicators flash twice.

» Confirmation tone sounds twice (if programmed).

» Anti-theft alarm (DWA) is active.

–with central locking system^{OE}
or

–with Keyless Ride^{OE}

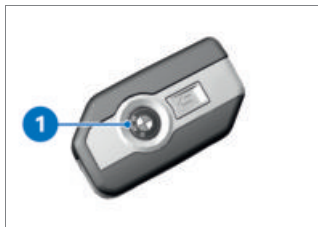

- Switch off the ignition (▮▮▮▮ 65).
- Press button **1** on the radio-operated key twice.



See also the other functions of the remote control for the central locking system.

» Activation takes 30 seconds to complete.

» Turn indicators flash twice.

» Confirmation tone sounds twice (if programmed).

» Anti-theft alarm (DWA) is active.◀

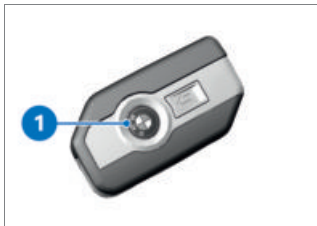

- To deactivate the tilt sensor (for example if you are about to transport the motorcycle on a train and the swaying movement of the moving train could trip the alarm), press button **1** on the radio-operated key again during the activation phase.

» Turn indicators flash three times.

» Confirmation tone sounds three times (if programmed).

» Tilt sensor is deactivated.

80 OPERATION

Alarm signal

A DWA alarm can be triggered by:

- Tilt sensor
- Switch-on attempt with an ignition key.
- Disconnection of the DWA anti-theft alarm from the motorcycle's battery (DWA internal battery in the anti-theft alarm provides power – acoustic alarm only, the turn indicators do not flash).
- with Keyless Ride^{OE}

 When the radio-operated key is within range, an alarm triggered by the tilt sensor is suppressed.◀

All functions are sustained even if the internal battery of the DWA anti-theft alarm system is flat; the only difference is that an alarm cannot be triggered if the system is disconnected from the motorcycle's battery.

An alarm lasts for approximately 26 seconds. While an alarm is in progress an alarm tone sounds and the turn indicators flash. The type of acoustic alarm tone can be set by an authorised BMW Motorrad retailer.



You can cancel an alarm at any time by pressing button **2** on the radio-operated key; this does not deactivate the DWA.

If an alarm was triggered while the motorcycle was unattended, the rider is notified accordingly by an alarm tone sounding once when the ignition is switched on. The indicator light in the instrument cluster then signals the reason for the alarm for one minute.

Light signals issued by the indicator light:

- Flashes 1x: Tilt sensor 1
- Flashes 2x: Tilt sensor 2
- Flashes 3x: Ignition switched on with unauthorised key
- Flashes 4x: Disconnection of the DWA anti-theft alarm from the motorcycle's battery
- Flashes 5x: Tilt sensor 3

Deactivation

- Switch on the ignition (▣▣▣ 64).
- » Turn indicators flash once.
- » Confirmation tone sounds once (if programmed).
- » DWA is switched off.
- with central locking system^{OE}
- or
- with Keyless Ride^{OE}

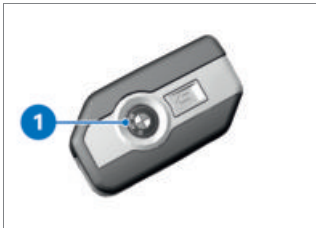

- Press button 1 on the radio-operated key once.

i If the alarm function is deactivated by the radio-operated key and the ignition is not subsequently switched on, the alarm function is automatically reactivated after approx. 30 seconds if Arm automatically is switched on.

- » Turn indicators flash once.
- » Ground light comes on for a short time.
- » Confirmation tone sounds once (if programmed).
- » DWA is switched off.◀

Adapting DWA

- Switch on the ignition (▣▣▣ 64).
- Navigate to Settings, Vehicle settings and select Alarm system.
- » The following adaptation settings are available:
 - Adapt Warning signal
 - Switch Tilt sensor on or off
 - Switch Arming tone on or off
 - Switch Arm automatically on or off

Possibilities for adjustment

Warning signal: Set the rising and falling or intermittent alarm tone.

Tilt sensor: Activate tilt sensor to monitor the inclination of the vehicle. The anti-theft alarm (DWA) is tripped if any attempt is made to steal a wheel or lift the vehicle for towing, for example.

i When the vehicle is going to be transported, deactivate the tilt sensor to prevent the anti-theft alarm (DWA) from being triggered.

Arming tone: In addition to turn indicators flashing, alarm tone sounds as confirmation of activation/deactivation of the DWA.

82 OPERATION

Arm automatically: Automatic activation of the alarm function when the ignition is switched off.

DYNAMIC TRACTION CONTROL (DTC)

Switching DTC function off and on

- Switch on the ignition (▣▣▣▣ 64).
- Navigate to *Settings, Assist* and select *DTC*.
- Deactivate *DTC* to switch off Dynamic Traction Control (DTC) temporarily until the next time the ignition is switched on.

 lights up.

- Activate *DTC* to switch on Dynamic Traction Control (DTC). Alternatively: Switch ignition off and on again.

 goes out, if self-diagnosis has not completed the DTC indicator and warning light starts flashing.

- For more information on Dynamic Traction Control (DTC), see the section entitled "Engineering details" (▣▣▣▣ 168).

ELECTRONIC SUSPENSION ADJUSTMENT (D-ESA)

Possibilities for adjustment, Dynamic ESA

Dynamic ESA is an electronic system that enables your motorcycle's suspension to adjust automatically to suit the load the vehicle is carrying.

For more information on Dynamic ESA, see the section entitled "Engineering details" (▣▣▣▣ 170).

Adjusting suspension damping

- Switch on the ignition (▣▣▣▣ 64).
- Navigate to *Settings, Assist* and select *Damping*.
- Select the desired suspension-damping setting.

 You can adjust the damping characteristic while the motorcycle is on the move.

 The suspension damping settings are retained in memory, even after the ignition is switched off.

Adjusting for loaded state

- Start the engine (▣▣▣▣ 147).
- Navigate to *Settings, Assist* and select *Load*.
- Select the desired loaded-state setting.

 The load setting is retained in memory, even after the ignition is switched off.

 The load cannot be set while the motorcycle is in motion.

The following message is displayed if no load setting is possible: *Action not possible. Engine must be on.*

The following message is displayed if no load setting is possible because speed is too high: *Action not possible. Speed too high.*

RIDING MODE

Use

BMW Motorrad has developed operational scenarios for your motorcycle from which you can select the scenario suitable for your situation:

- RAIN: Riding on rain-wet roads.
- ROAD: Riding on dry roads.
- DYNAMIC: Dynamic riding on a dry road surface.

The optimum interplay of engine characteristic, chassis and suspension settings and DTC control is provided for each of these scenarios.

 See the section entitled "Engineering details" for more information on the selectable riding modes.

Setting riding mode

- Switch on the ignition (➔ 64).



- Press button 1.

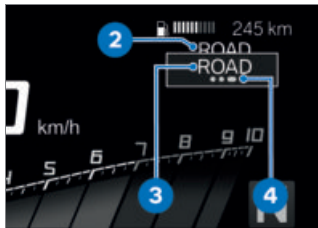

The riding mode currently active 2 is sent to the back and is displayed in the pop-up 3. The

84 OPERATION

guide 4 indicates how many riding modes are available.



- Repeatedly press button 1 until the riding mode you want is displayed.
 - » With the vehicle at a standstill, the selected mode is activated after approximately 2 seconds.
 - » The following conditions must be satisfied for activation of a new riding mode while riding:
 - Throttle grip is in idle position.
 - Brake is not applied.
 - Adaptive cruise control is deactivated.
 - » The riding mode selected in this way is retained, with the engine-characteristic and DTC adaptation settings, even after the ignition has been switched off.

ADAPTIVE CRUISE CONTROL

Display when adjusting settings (Speed Limit Info not active)



The symbol 1 for adaptive cruise control is displayed in the Pure Ride view and in the top status line.

Display when adjusting settings (Speed Limit Info active)



The symbol 1 for adaptive cruise control is displayed in the Pure Ride view and in the top status line.

Switching on adaptive cruise control



WARNING

Use of cruise control in unsuitable road conditions

Risk of falling

- Do not use cruise control when road conditions are unsuitable, for example in snow, ice, heavy rain, off-road or on slippery surfaces.
- Do not use cruise control on very twisty stretches of road.



- Slide switch **1** to the right.
 - » Button **2** is enabled for operation.

Setting road speed



- Short-push button **1** forward.



Adjustment range for adaptive cruise control (gear-dependent)

15...220 km/h



is displayed.

- » The motorcycle maintains your current cruising speed and the setting is saved.

Accelerating



Depending on which unit of speed is selected in the instrument cluster, speed is increased or decreased in either km/h or mph.

86 OPERATION



- Short-push button **1** forward.
 - » Speed is increased by approx. 1 km/h or 1 mph, as applicable, each time you push the button.
- Push button **1** forward and hold it in this position.
 - » Speed is increased in steps of 10 km/h or 5 mph, as applicable.
 - » The current speed is maintained and saved if button **1** is not pushed again.

Decelerating

 Depending on which unit of speed is selected in the instrument cluster, speed is increased or decreased in either km/h or mph.



- Short-push button **1** back.
 - » Speed is reduced by 1 km/h or 1 mph, as applicable, each time you push the button.
- Push button **1** back and hold it in this position.
 - » Speed is reduced in steps of 10 km/h or 5 mph, as applicable.
 - » The current speed is maintained and saved if button **1** is not pushed again.

Deactivating adaptive cruise control

- Brake or turn the throttle grip (close the throttle by turning the grip back past the idle position) to deactivate adaptive cruise control.

 Cruise control is deactivated if the clutch is pulled for longer than 1.5 seconds.

- » A message appears on the display.

Resuming former cruising speed

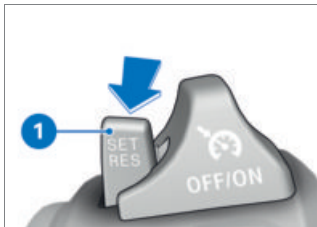

- Short-push button **1** back to return to the speed saved beforehand.

 Opening the throttle does not deactivate cruise control. When the twistgrip is released the motorcycle decelerates only to the speed saved in memory, even if the rider intended slowing to a lower speed.



is displayed.

Switching off adaptive cruise control



- Slide switch **1** to the left.

» The system is deactivated.



disappears.

» Button **2** is disabled.

HILL START CONTROL

Setting up Hill Start Control Pro

- Switch on the ignition (➡ 64).
- Navigate to *Settings*, *Assist* and select *HSC Pro*.
- To switch on manual Hill Start Control Pro, select *Manual*.
 - » Hill Start Control Pro can be activated by forcefully operating the handbrake or foot-brake lever.
- To switch off Hill Start Control Pro, select *Off*.
 - » Hill Start Control Pro is deactivated.
- To switch on automatic Hill Start Control Pro, select *Auto*.
 - » Hill Start Control Pro can be activated by forcefully operating the handbrake or foot-brake lever.
 - » If the brake is actuated for approximately one second after the vehicle has come to a standstill and the motorcycle is on a gradient of at least 3%, Hill Start Control Pro is automatically activated.

88 OPERATION

» The selected setting remains stored even after the ignition is switched off.



Symbol **1** for Hill Start Control is displayed in the top status line and in the Pure Ride view.

Operating Hill Start Control Pro

Requirement

Vehicle stationary and upright, engine running.

ATTENTION

Failure of Hill Start Control

Risk of accident

- Apply the brakes manually to hold the vehicle.

 The drive-off assistant Hill Start Control Pro is only a comfort system to enable easier riding off on gradients and should not be confused with an electromechanical holding brake.

 The Hill Start Control Pro drive-off assistant should not be used on inclines of over 40 %.

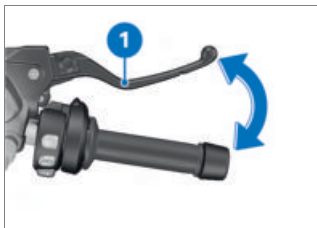

- Apply firm pressure to handbrake lever **1** or to the footbrake lever and then quickly release the lever.
- Alternatively, apply the brake for about one second beyond the vehicle reaching a standstill on an incline of at least 3 %.

 shows green.

- » Hill Start Control Pro is activated.
- To switch off Hill Start Control Pro, operate handbrake lever **1** or the footbrake lever again.

 If Hill Start Control Pro has been deactivated by means of the handbrake lever, automatic Hill Start Control is deactivated for the next 4 m.

 is displayed in white.

- Alternatively, ride off in 1st or 2nd gear.

 When riding off, Hill Start Control Pro is automatically deactivated.

 disappears as soon as the brake is fully released.

» Hill Start Control Pro is deactivated.

- For more information on Hill Start Control Pro, see the section entitled "Engineering details" (📖 174)

REVERSER

Requirements

The following prerequisites must have been met to be able to use the reverser:

- Motorcycle at standstill.
- Engine running.
- Brake applied.
- Transmission in idle.
- Side stand has been retracted.
- Clutch is not disengaged.

Reverse without passenger.

On uphill/downhill gradients the reverser cannot guarantee the vehicle is held, as would be the case if a gear were engaged.

Do not use the reverser on excessive uphill/downhill gradients.



Activating the reverser



- Press button **1**.
- » Gear indicator **2** switches from N to R.
- » You can use the reverser as soon as the "R" indicator stops flashing.

Using the reverser



- Release the brake.
- Press and hold starter button **1** to reverse.

90 OPERATION

Automatic termination

Reversing is cancelled automatically:

- On excessive uphill/downhill gradients
- In the event of obstructions
- If the reversing motor has overheated
- If the side stand has been extended
- If the brake is operated

If reversing is cancelled, the "R" in the display flashes.

Deactivating the reverser



- Press button **1**.
- » Gear indicator switches from R to N.

CENTRAL LOCKING SYSTEM

-with central locking system^{OE}

Locking



- Switch on the ignition and press button **1**.
 - Alternatively: Press button **2** on the radio-operated key.
 - » The storage compartments and the cases are locked.
-  is displayed.

Unlocking



- Switch on the ignition and press button **1**.
- Alternatively: Press button **2** on the radio-operated key.
- » The storage compartments and the cases are unlocked.
- » Once a lock has been locked manually it subsequently has

to be unlocked manually as well.

Emergency unlocking

To manually open cases and storage compartments with the ignition key if it is no longer possible to unlock the central locking system:

- Open the cases (▮▮▮ 94).
- Opening and closing storage compartment (▮▮▮ 96).

HEATING

Operating heated handlebar grips

 The heating in the heated handlebar grips can be activated only when the engine is running.

 The increase in power consumption caused by having the heated handlebar grips switched on can drain the battery if you are riding at low engine speeds. If the charge level is low, the heated handlebar grips are switched off to ensure the battery's starting capability.

- Start the engine (▮▮▮ 147).
- Navigate to *Settings*, *Heating* and select *Grip heating*.

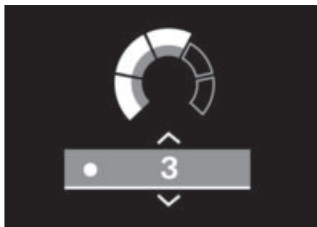

The grips have five-stage heating. Stage five is for heating the grips quickly: it is advisable to switch back to a lower stage as soon as the grips are warm.

- Select the desired heating stage.

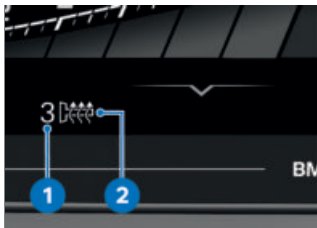

Selected heating stage **1** and heated-grip symbol **2** are displayed.

Operating rider's seat heating

 Seat heating can be activated only when the engine is running.

- Start the engine (▮▮▮ 147).

92 OPERATION

- Navigate to Settings, Heating and select Seat heating.

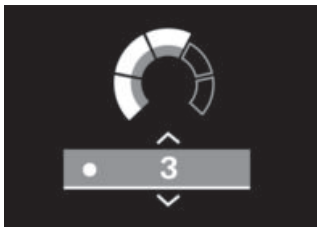

The rider's seat has five-stage heating. Stage five is for heating the seat quickly: it is advisable to switch back to a lower stage as soon as the seat is warm.

- Select the desired heating stage.

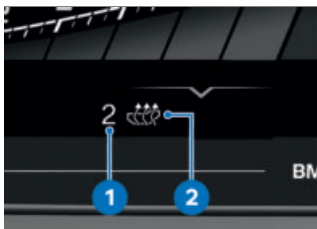

Selected heating stage **1** and seat-heating symbol **2** are displayed.

Operating passenger-seat heating

 Seat heating can be activated only when the engine is running.

- Start the engine (➡ 147).



- Set switch **1** to the desired heating stage.



The passenger seat has two-stage heating. Stage two is for heating the seat quickly: it is advisable to switch back to stage one as soon as the seat is warm.

- 2** Switch centred: Heating off.
- 3** Switch pressed at one dot: low heating power.

- 4 Switch pressed at two dots:
high heating power.

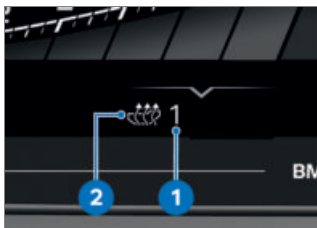

Selected heating stage **1** and seat-heating symbol **2** are displayed.

SLIPSTREAM DEFLECTOR



1 Slipstream deflector



WARNING

Adjusting the slipstream deflector while riding.

Risk of accident

- Adjust the slipstream deflector when the motorcycle is at a standstill.

Opening or closing the slipstream deflectors influences the extent to which cooling air from the slipstream is directed toward or away from the rider.



- A** Slipstream deflectors closed: High level of protection against wind and weather, highest level of riding comfort.
- B** Slipstream deflectors open: Increased flow of air from slipstream directed toward the rider, increased cooling effect when outside temperatures are high.



With the slipstream deflectors opened, at high speeds turbulence occurring around the helmet can have a negative effect on riding comfort. BMW Motorrad recommends closing the slipstream deflector.

94 OPERATION

ors in preparation for riding at high speeds.

SEAT

Removing seat

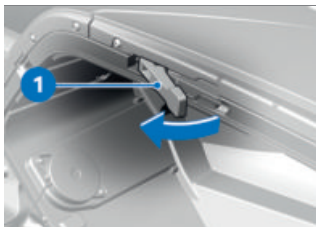

- Open left case.
- Operate release **1** and lift the rear slightly at the rear.

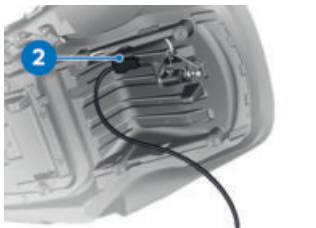

- Disconnect plug connection **2** of the seat heating and remove the seat.
- Place the seat, upholstered side down, on a clean surface.

Installing seat

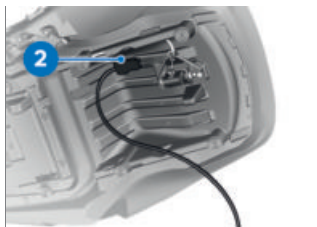

- Connect plug connection **2** for the seat heating.

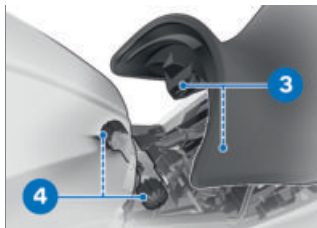

- Position the seat with mounts **3** in rubber buffers **4** on left and right.
- Lower the rear of the seat and engage the seat in the latching mechanism.

CASES

Opening cases

- with central locking system^{OE}
- If necessary, unlock the central locking system.◁



- Turn the key to the in the case lock to the position indicated by the dot.



- Press lock barrel **1** down.
» Release lever **2** pops up.
- Pull release lever **2** all the way up and open the case lid.

Closing cases



- Pull release lever **2** all the way up.
- Close the lid of the case and press it down. Check that nothing is trapped between the lid and the case.



The case can also be snapped shut when the lock is in the **LOCK** position. Make sure that the ignition key is not left inside the case.

- Push release lever **2** down until it engages.
- Turn the key in the case lock to the **LOCK** position and remove the key from the lock.

Maximum payload

Note the maximum payload and the maximum permissible speed.

The values for the combination described here are as follows:



Maximum speed for riding with a loaded case

max 180 km/h

96 OPERATION



Payload per case

max 10 kg

STORAGE COMPARTMENTS

Opening and closing storage compartment

—with central locking system^{OE}

- If necessary, unlock the central locking system. ◀



- Turn the key in the storage compartment lock to the position indicated by the dot.
- Press the unlocked lock barrel to open the flap.
- The description applies by analogy to the storage compartment on the right side.



ATTENTION

High temperatures in the storage compartments, particularly in summer

Damage to objects stowed away, particularly electronic devices, such as mobile phones and MP3 players

- Consult the operating instructions of your electronic device and check for possible usage restrictions.

- In summer, do not place heat-sensitive objects in the storage compartments.

Opening and closing charging storage compartment

 The charging storage compartment can be opened only when the windscreen is at its top limit position.

- Adjust the windscreen (▮▮▮▮▶ 138).

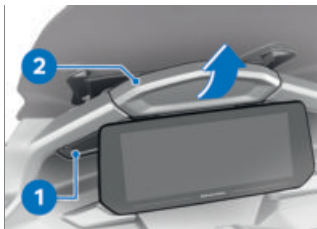

- Press button **1** and open lid **2** in the direction indicated by the arrow.
- To close: Firmly press lid **2** into the lock.

 The charging storage compartment cannot be locked.



ATTENTION

High temperatures in the storage compartments, particularly in summer

Damage to objects stowed away, particularly electronic devices, such as mobile phones and MP3 players

- Consult the operating instructions of your electronic device and check for possible usage restrictions.

- In summer, do not place heat-sensitive items in the charging storage compartment.

Ventilation

To ensure adequate circulation of air, a fan is switched on if the temperature in the charging storage compartment rises above 30 °C. The fan switches off again as soon as the temperature inside the charging storage compartment is less than 25 °C.

Charging smartphone Requirement

Ignition is switched on.

- Open the charging storage compartment.



- Flip retainer **1** up.

98 OPERATION



- Connect smartphone **2** to USB-C charging interface **3** and place the smartphone, display to the front as viewed in the forward direction of travel, in the charging storage compartment.

 BMW Motorrad recommends using the BMW Motorrad USB cable for charging smartphones inside the storage compartment. Another commercially available charging cable might not have sufficient space in the storage compartment and could suffer damage.



- Flip retainer **1** down.
 - Close lid **2**.
- » The smartphone is secured.

Notes on use

The storage compartment is suitable for smartphones up to max 158 mm x 78 mm x 10 mm in size. For small mobile phones that might not be held securely by the holder, BMW Motorrad recommends using the BMW Motorrad smartphone pouch.

Charge current

This is a 5 V USB-C charging interface that provides a maximum charge current of 1.5 A (maximum charging power 7.5 W).

Automatic shutdown

The USB-C charging interface is shut down automatically under the following circumstances:

- If battery charge state is too low, to maintain the vehicle's start capability.
- If the maximum load capacity as stated in the technical data is exceeded.
- During the starting operation.

TFT DISPLAY

05

GENERAL NOTES	102
PRINCIPLE	103
PURE RIDE VIEW	109
SPLITSCREEN	110
GENERAL SETTINGS	111
BLUETOOTH	112
WIFI	115
MY VEHICLE	116
ON-BOARD COMPUTER	119
NAVIGATION	120
MEDIA	122
TELEPHONE	123
FAVOURITES BUTTONS	124
DISPLAY SOFTWARE VERSION	124
DISPLAY LICENCE INFORMATION	124

102 TFT DISPLAY

GENERAL NOTES

Warnings

WARNING

Operation of a smartphone while riding the vehicle

Risk of accident

- Always comply with the road traffic regulations in force where you are riding.
- Do not use a smartphone while riding. This applies with the exception of applications without operation, such as hands-free telephony.

WARNING

Distraction from the road and loss of control

Operating the integrated information system and communication devices while driving results in a risk of accident

- Operate those systems or devices only when the traffic situation allows for it.
- If necessary, stop and operate the systems or devices when stationary.

Connectivity functions

Connectivity functions include media, telephony and navigation. Connectivity functions can be used when the TFT display is connected to a mobile device and a helmet (113). For more information on the Connectivity functions go to: **bmw-motorrad.com/connectivity**

 If the fuel tank is between the mobile device and the TFT display, the Bluetooth connection may be restricted. BMW Motorrad recommends storing the device above the fuel tank (e.g. in your jacket pocket).

 Depending on the mobile device, the scope of the Connectivity functions may be restricted.

BMW Motorrad Connected app

The BMW Motorrad Connected app enables the user to call up usage data and vehicle status information. For some functions such as navigation, for example, the app has to be installed on the mobile device and paired to the TFT-display. The app is used to start route guidance and adjust the naviga-

ation. In addition to Bluetooth pairing, the WiFi function has to be activated on the mobile device.

 On some mobile devices, e.g. those with iOS operating systems, the BMW Motorrad Connected App must be opened before use.

Currency

The TFT display may be updated after the publication date. Because of this, your motorcycle may differ from the information supplied in the Rider's Manual. Up-to-date information is available at: **bmw-motorrad.com/service**

PRINCIPLE

Controls

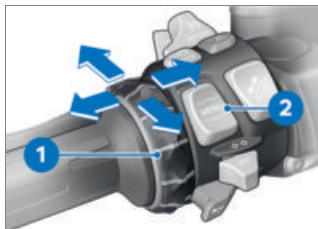

All display content is controlled by means of the Multi-Controller **1** and MENU rocker button **2**.

Depending on the context, various functions are possible.

Functions of the Multi-Controller

Turn Multi-Controller up:

- Move the cursor up in lists.
- Adjust settings.
- Increase volume.

Turn Multi-Controller down:

- Move the cursor down in lists.
- Adjust settings.
- Decrease volume.

Tilt Multi-Controller to the left:

- Activate the function in accordance with the operation feedback.
- Activate the function to the left or back.
- Go back to the Menu view after making the settings.
- In Menu view: Change up one level.
- In the *My vehicle* menu: Advance one menu screen.
- In the Pure Ride view: Return to the previous splitscreen display.

Tilt Multi-Controller to the right:

- Activate the function in accordance with the operation feedback.
- Confirm selection.
- Confirm settings.

104 TFT DISPLAY

- Advance a menu step.
- Scroll to the right in lists.
- In the *My vehicle* menu:
 - Advance one menu screen.
- In the Pure Ride view: Advance to the next splitscreen display.

MENU rocker button functions

 Instructions given by the navigation system are displayed in a dialogue box if the Navigation menu has not been called up. Operation of the MENU rocker button is temporarily restricted.

Short-press the top section of the MENU button:

- In Menu view: Change up one level.
- In Pure Ride view: Change the display for rider info. status line.

Long-press the top section of the MENU button:

- In Menu view: Call up Pure Ride view.

Short-press the bottom section of the MENU button:

- Change down a level.
- No function if the lowest hierarchical level has been reached.

Long-press the bottom section of the MENU button:

- Change back to the last menu after a previous menu change effected by long-pressing the top section of the MENU rocker button.

Operating pointers in the main menu

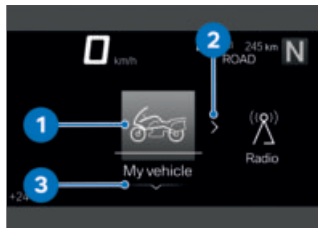

Operating pointers show whether interactions are possible, and which ones.

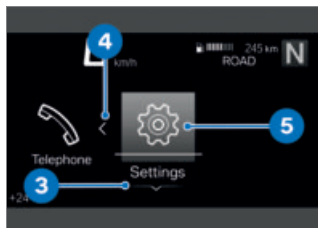

Meaning of the operating pointers:

- Operating pointer 1: Left end reached.
- Operating pointer 2: You can scroll to the right.

- Operating pointer **3**: You can scroll down.
- Operating pointer **4**: You can scroll to the left.
- Operating pointer **5**: Right end reached.

Operating pointers in submenus

In addition to the operating pointers in the main menu, there are additional operating pointers in the submenus.

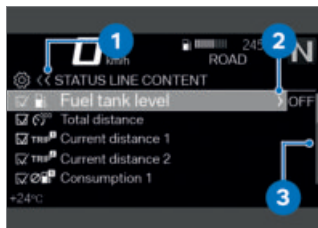

Meaning of the operating pointers:

- Operating pointer **1**: The current display is in a hierarchical menu. One symbol represents one submenu level. Two symbols represent two or more submenu levels. The colour of the symbol changes, depending on whether you can return to a higher level.
- Operating pointer **2**: One more submenu level can be accessed.

- Operating pointer **3**: There are more entries than can be displayed.

Display Pure Ride view

- Long-press the top section of the MENU rocker button.

Switching functions on and off

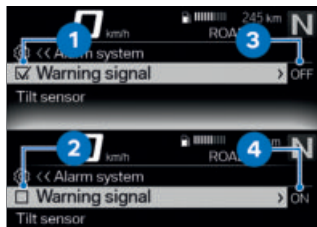

Some menu items have a check box in front of them. The check box shows whether the function is on or off. Action symbols after the menu items indicate what action you can trigger by short-tilting the Multi-Controller to the right.

Examples for switching on and off:

- Symbol **1** shows that the function is switched on.
- Symbol **2** shows that the function is switched off.
- Symbol **3** shows that the function can be switched off.
- Symbol **4** shows that the function can be switched on.

106 TFT DISPLAY

Calling up menu

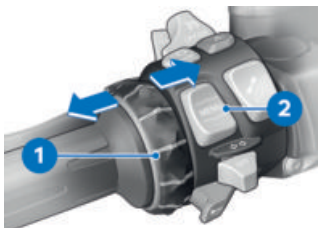

- Display Pure Ride view (▣▣▣▣ 105).
- Short-press the bottom section of button **2**.

The following menus can be called up:

- My vehicle
- Radio
- Navigation
- Media
- Telephone
- Settings

- Repeatedly short-push Multi-Controller **1** to the right until the menu item you want is highlighted.
- Short-press the bottom section of button **2**.

Moving cursor in lists

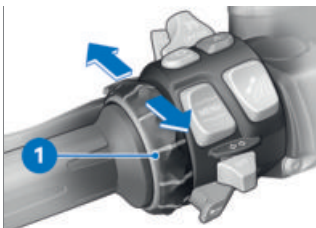

- Call up the menu (▣▣▣▣ 106).
- To move the cursor down in a list, turn Multi-Controller **1** down until the entry you want is highlighted.
- To move the cursor up in a list, turn Multi-Controller **1** up until the entry you want is highlighted.

Confirming selection

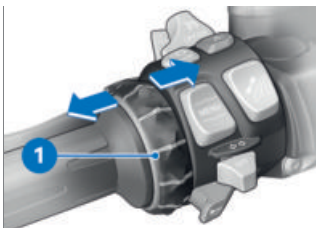

- Select the desired entry.
- Short-push Multi-Controller **1** to the right.

108 TFT DISPLAY



Break 2



Speed 1 (Average)



Speed 2 (Average)



Tyre pressure



Fuel tank level



Range

Selecting content of top status line

- Navigate to Settings, Display, Status line content.
- Switch on the desired displays.
- » You can switch between the selected displays in the top status line. If no displays are selected, only the range will be displayed.

Adjust settings

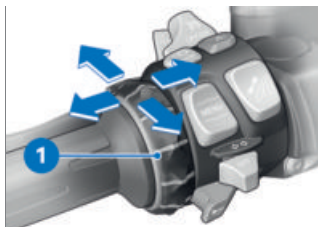

- Select and confirm the desired settings menu.
- Turn Multi-Controller **1** down until the setting you want is highlighted.
- If an operating pointer shows, tilt Multi-Controller **1** to the right.
- If no operating pointer shows, tilt Multi-Controller **1** to the left.
- » The setting is saved.

Switching Speed Limit Info on or off

Requirement

Vehicle is connected with a compatible mobile device. The BMW Motorrad Connected app is installed on the mobile device.

- Speed Limit Info shows the maximum speed permitted at the time, if this information is made available by the publisher of the map material in the navigation system.

- Navigate to Settings, Display.
- Switch Speed Limit Info on or off.

PURE RIDE VIEW

Rev. counter

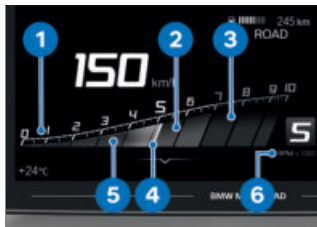

- 1 Scale
- 2 Low engine speed range
- 3 Upper/red engine speed range
- 4 Needle
- 5 Secondary indicator
- 6 Unit for engine speed display:
1000 revolutions per minute

 The red engine speed range changes depending on the coolant temperature: The colder the engine, the lower the engine speed at which the red engine speed range starts. The warmer the engine, the higher the speed at which the red engine speed range starts.

When operating temperature is reached, the display of the red engine speed range no longer changes.

Range



The range readout **1** indicates how far you can ride with the fuel remaining in the tank. This distance is calculated on the basis of average consumption and the quantity of fuel on board.

- When the vehicle is propped on its side stand the slight angle of inclination means that the sensor cannot register the fuel level correctly. This is the reason why the range is recalculated only when the side stand is in the retracted position.
- The range is shown together with a warning once the fuel reserve has been reached.
- After a refuelling stop, range is recalculated if the amount

110 TFT DISPLAY

of fuel in the tank is greater than the reserve quantity.

–The calculated range is only an approximate figure.

Recommendation to upshift



The recommendation to upshift in the Pure Ride view **1** or in the status line **2** indicates the best time to upshift economically.

SPLITSCREEN

Switching on splitscreen view and selecting display

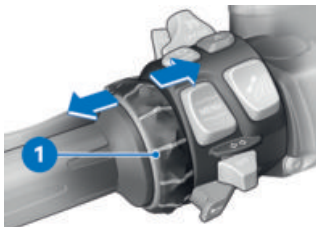

- Display Pure Ride view (➡ 105).
- Repeatedly short-push Multi-Controller **1** to the right or

left until the display you want appears.

- Alternatively: Long-push Multi-Controller **1** to the right to return to the display last selected in splitscreen view. The following displays can be selected:

- ON-BOARD COMPUTER
- TRIP COMPUTER
- Navigation
- MEDIA

MEDIA or RADIO can be displayed, depending on the selected audio source.

» The display you select is retained in memory, even after the ignition is switched off.

Switching off splitscreen

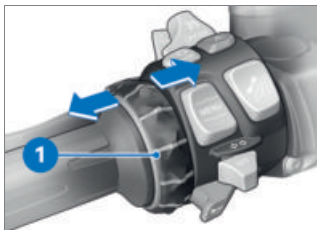

- Display Pure Ride view (➡ 105).
- Repeatedly short-push Multi-Controller **1** to the left until the splitscreen view is switched off.

- Alternatively: Long-push Multi-Controller **1** to the left.

GENERAL SETTINGS

Adjusting volume

- Connect rider's and passenger's helmet (▣▣▣ 114).
 - To increase volume: Turn Multi-Controller up.
 - To reduce volume: Turn Multi-Controller down.
 - To mute: Turn Multi-Controller all the way down.
- » Muting pauses media playback.

Setting the date

- Switch on the ignition (▣▣▣ 64).
- Navigate to Settings, System settings, Date and time, Set date.
- Set Day, Month and Year.
- Confirm setting.

Set date format

- Navigate to Settings, System settings, Date and time, Date format.
- Select the desired setting.
- Confirm setting.

Setting clock

- Switch on the ignition (▣▣▣ 64).
- Navigate to Settings, System settings, Date and time, Set time.
- Set Hour and Minute.

Setting time format

- Navigate to Settings, System settings, Date and time, Time format.
- Select the desired setting.
- Confirm setting.

Setting units of measurement

- Navigate to Settings, System settings, Units.
- The following units of measurement can be set:
- Pressure
 - Temperature
 - Speed
 - Consumption

Setting language

- Navigate to Settings, System settings, Language.
- The following languages can be set:
- German
 - English (UK)
 - English (US)
 - Spanish
 - French
 - Italian
 - Dutch
 - Polish
 - Portuguese (Brazil)
 - Portuguese (Portugal)
 - Turkish
 - Russian
 - Ukrainian
 - Chinese
 - Japanese
 - Korean
 - Thai

112 TFT DISPLAY

Adjusting brightness

- Navigate to `Settings`, `Display`, `Brightness`.
- Adjust display brightness.
- » When ambient brightness drops below a defined threshold, the display is dimmed to the brightness set here.
- » If the TFT display is faulty, consult the troubleshooting chart in the section entitled "Technical data". (▶▶▶ 221)

Resetting all settings

- All the settings in the `Settings` menu can be reset to the factory settings.
- Call up the `Settings` menu.
- Select `Reset all` and confirm.

The settings in the following menus are reset:

- Vehicle settings
- System settings
- Connections
- Display
- Information

- » Existing Bluetooth connections are not deleted.

BLUETOOTH

Short-range wireless technology

Bluetooth is a short-range wireless technology. Bluetooth devices are short-range devices transmitting on the license-free ISM band (Industrial, Scientific, Medical) between 2.402 GHz and 2.480 GHz. They can be operated anywhere in the world without a licence being required.

Although Bluetooth is designed to establish and sustain robust connections over short distances, as with every other wireless technology disruptions are possible. Interference can affect connections or connections can sometimes fail. Particularly when multiple devices operate in a Bluetooth network, with wireless technology of this nature it is not possible to ensure fault-free communications in every situation.

Possible sources of interference:

- interference zones due to transmission masts and similar.
- devices with non-compliant Bluetooth implementations.

- proximity of other Bluetooth-compatible devices.
- Shielding by metal objects or bodies.

Pairing

Two Bluetooth devices have to recognise each other before they can communicate. This process of mutual recognition is known as pairing. When two devices have paired they remember each other, so the pairing process is conducted only once, on initial contact.

 On some mobile devices, e.g. those with iOS operating systems, the BMW Motorrad Connected App must be opened before use.

During the pairing process, the TFT display searches for other Bluetooth-compatible devices within its reception range. The conditions that have to be satisfied before the audio system can recognise another device are as follows:

- The device's Bluetooth function must be active
- The device must be "visible" to others
- Other Bluetooth-compatible devices that are not to be paired (e.g. mobile phones

and navigation systems) must be OFF.

Please consult the operating instructions for your communication system.

Pairing

- Call up the `Settings, Connections` menu.

» Bluetooth connections can be established, managed and deleted in the `CONNECTIONS` menu. The following Bluetooth connections are displayed:

- Mobile device
- Rider's helmet
- Passenger helm.

The connection status for mobile devices is displayed.

Connect mobile device

- Pairing ( 113).
 - Activate the mobile device's Bluetooth function (see mobile device's operating instructions).
 - Select `Mobile device` and confirm.
 - Select `Pair new mobile device` and confirm.
- Mobile devices are being searched for.

 flashes in the bottom status line during pairing.

114 TFT DISPLAY

Mobile devices found are displayed.

- Select and confirm mobile device.
- Follow the instructions on the mobile device.
- Confirm that the code matches.
 - » The connection is established and the connection status updated.
 - » If the connection is not established, consult the troubleshooting chart in the section entitled "Technical data". (▣▣▣ 220)
 - » Depending on the mobile device, telephone data is transferred to the vehicle automatically.
 - » Telephone data (▣▣▣ 123)
 - » If the phonebook is not displayed, consult the troubleshooting chart in the section entitled "Technical data". (▣▣▣ 222)
 - » If the Bluetooth connection does not work as expected, consult the troubleshooting chart in the section entitled "Technical data". (▣▣▣ 221)

Connect rider's and passenger's helmet

- Pairing (▣▣▣ 113).

- Select Rider's helmet or Passenger helm. and confirm.
- Make the helmet's communication system visible.
- Select Pair new rider's helmet or Pair new passenger helmet and confirm. Helmets are searched for.



flashes in the bottom status line during pairing.

Helmets found are displayed.

- Select and confirm helmet.
 - » The connection is established and the connection status updated.
 - » If the connection is not established, consult the troubleshooting chart in the section entitled "Technical data". (▣▣▣ 220)
 - » If the Bluetooth connection does not work as expected, consult the troubleshooting chart in the section entitled "Technical data". (▣▣▣ 221)

Deleting connections

- Call up the Settings, Connections menu.
- Select Delete connections.
- To delete an individual connection, select the connection and confirm.

- To delete all connections, select `Delete all connections` and confirm.

WiFi

WiFi connection

A WiFi connection is used to transmit the map view from a mobile phone to the TFT display. WiFi has to be activated on the mobile phone in order for the full scope of this functionality to be used. For more information on activating WiFi see the operating instructions for the mobile phone.

Depending on the specifics of the local situation, for example in the presence of numerous wifi networks, temporary restrictions and loss of connection are possible.

116 TFT DISPLAY

MY VEHICLE START SCREEN

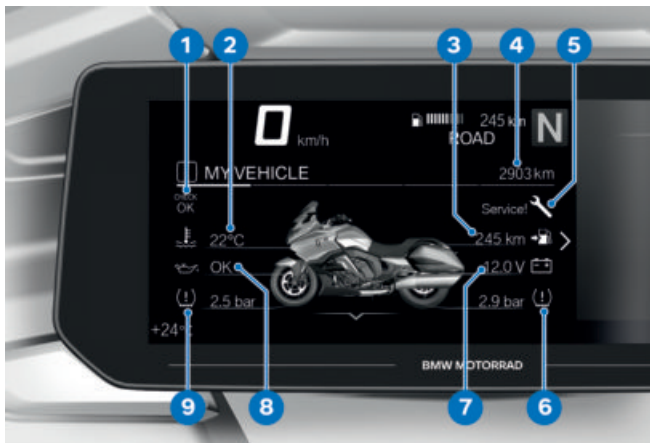

- 1 Check Control display
Mode of presentation
(⇒ 31)
- 2 Coolant temperature
(⇒ 45)
- 3 Range (⇒ 109)
- 4 Odometer
- 5 Service display (⇒ 60)
- 6 Tyre pressure, rear
(⇒ 48)
- 7 On-board voltage
(⇒ 200)
- 8 Engine oil level (⇒ 45)
- 9 Tyre pressure, front
(⇒ 48)

Operating pointers

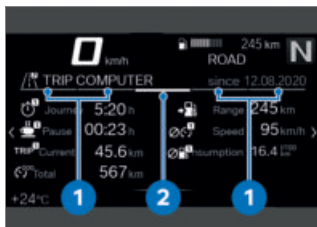

- Operating pointer 1: Indicators showing how far you can scroll to the left or right.
- Operating pointer 2: Indicator showing the position of the current menu screen.

Scrolling through menu screens

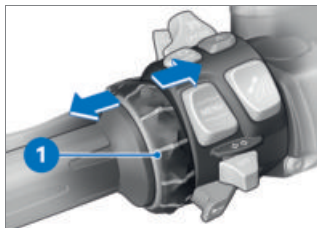

- Call up the My vehicle menu.
- To scroll to the right, short-push Multi-Controller 1 to the right.
- To scroll to the left, short-push Multi-Controller 1 to the left.

The My vehicle menu contains the following screens:

- MY VEHICLE
- ON-BOARD COMPUTER
- TRIP COMPUTER
- TYRE PRESSURE
- SERVICE REQUIREMENTS
- CC MESSAGE (if available)

- For more information on Check Control messages, see the section entitled "Displays" (▶▶ 31).

 Check Control messages are attached dynamically to the menu screens as additional tabs in the My vehicle menu.

On-board computer and trip computer

The ON-BOARD COMPUTER and TRIP COMPUTER menu screens display vehicle and trip data, such as average values.

Service requirements

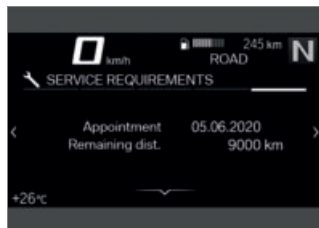

When the next service is due within less than a month or

118 TFT DISPLAY

within 1000 km, a white Check Control message is displayed.

ON-BOARD COMPUTER

Calling up on-board computer

- Call up the *My vehicle* menu.
- Scroll to the right until the ON-BOARD COMPUTER menu screen is displayed.
- » Alternatively, the on-board computer can also be shown on the splitscreen.
- Switch on splitscreen view and select display (➡ 110).

Resetting on-board computer

- Call up the on-board computer (➡ 119).
- Press down the MENU rocker button.
- Select *Reset all values* or *Reset individual values* and confirm.

The following values can be reset:



Break



Journey



Current



Speed



Consump.

Calling up trip computer

- Call up the on-board computer (➡ 119).
- Scroll to the right until the TRIP COMPUTER menu screen is displayed.
- » Alternatively, the trip computer can also be shown on the splitscreen.
- Switch on splitscreen view and select display (➡ 110).

Resetting trip computer

- Call up the trip computer (➡ 119).
- Press down the MENU rocker button.
- Select *Autom. reset* or *Reset all values and confirm*.
- » If *Autom. reset* is selected, the trip computer is automatically reset when a minimum of 6 hours have passed and the date has changed since the ignition was switched off.

NAVIGATION

Warnings



WARNING

Operation of a smartphone while riding the vehicle

Risk of accident

- Always comply with the road traffic regulations in force where you are riding.
- Do not use a smartphone while riding. This applies with the exception of applications without operation, such as hands-free telephony.



WARNING

Distraction from the road and loss of control

Operating the integrated information system and communication devices while driving results in a risk of accident

- Operate those systems or devices only when the traffic situation allows for it.
- If necessary, stop and operate the systems or devices when stationary.

Precondition

The vehicle is connected via Bluetooth to a compatible mobile device.

The BMW Motorrad Connected app is installed on the connected mobile device.



On some mobile devices, e.g. those with iOS operating systems, the BMW Motorrad Connected App must be opened before use.

Showing map view

Requirement

WiFi is activated on the Bluetooth-paired mobile device.

- Connect mobile device (📶 113).
- Call up the BMW Motorrad Connected app.
- Call up the `Navigation` menu.



If the `NAVIGATION` view is selected in splitscreen and the `NAVIGATION` menu is called up, the splitscreen view is automatically exited and the entire TFT display is used for navigation.

Entering destination address

- Connect mobile device (📶 113).

- Call up the BMW Motorrad Connected app and start the route guidance.
- Call up the **Navigation** menu.
 - » Active route guidance is displayed.
 - If WiFi is not activated on the mobile device, route guidance is displayed as arrow navigation.
 - » If active route guidance is not displayed, consult the troubleshooting chart in the section entitled "Technical data". (►► 222)

Selecting destination from recent destinations

- Call up the **Navigation, Recent destinations** menu.
- Select and confirm destination.
- Select **Start route guidance**.

Selecting destination from favourites

- The **FAVOURITES** menu displays all the destinations saved as favourites in the BMW Motorrad Connected app. You cannot use the TFT display to add favourites to the list.
- Navigate to **Navigation, Favourites**.

- Select and confirm destination.
- Select **Start guidance**.

Entering special destinations

- Special destinations, such as points of interest, can be displayed on the map.
- Call up the **Navigation, POIs** menu.

The following locations can be selected:

- At current location
- At destination
- Along the route
- Select where the special destinations should be looked for. For example, the following special destination can be selected:
 - Filling station
- Select and confirm the special destination.
- Select **Start route guidance** and confirm.

Setting route criteria

- Call up the **Navigation, Route criteria** menu. The following criteria can be selected:
 - Route type
 - Avoid
 - Select desired **Route type**.
 - Switch desired **Avoid** on or off.
- The number of avoidances activated is displayed in brackets.

122 TFT DISPLAY

Ending route guidance

- Call up the Navigation, Active route guidance menu.
- Select End route guidance and confirm.

Switching spoken instructions on or off

- Connect rider's and passenger's helmet (►► 114).
- The navigation can be read out by a computer voice. For this purpose, Spoken instruction must be switched on.
- Call up the Navigation, Active route guidance menu.
- Switch Spoken instruction on or off.

Repeating last spoken instruction

- Call up the Navigation, Active route guidance menu.
- Select Current instruction and confirm.



MEDIA

Precondition

The vehicle is connected to a compatible mobile device and helmet.

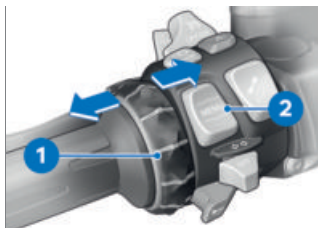
Control music playback



- Call up the Media menu.
-  BMW Motorrad recommends setting the volume on the mobile end device for media and calls to maximum before setting off.
- Adjust the volume (►► 111).
- To select the next track in the player: short-tilt Multi-Controller **1** to the right.
- To select the preceding track or start of current track: Short-tilt Multi-Controller **1** to the left.
- Call up context menu: Press bottom section of button **2**.
-  Depending on the mobile device, the scope of the Connectivity functions may be restricted.
- » The following functions can be used in the context menu:
 - Playback or Pause.
 - Select the Now playing, All artists, All albums or

All tracks category for search and playback.

–Select Playlists.

You can make the following adjustments in the Audio settings submenu:

–Switch Shuffle on or off.

–Repeat: Select Off, One (current track) or All.

–Select Output device.

–Select Sound profile.

–Set up Equaliser.

» If the playlist is not shown on the TFT display, consult the troubleshooting chart in the section entitled "Technical data". (►► 222)

TELEPHONE

Precondition

The vehicle is connected to a compatible mobile device and helmet.

Telephone calls

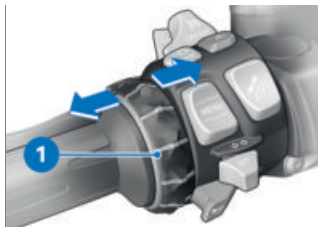

- Call up the Telephone menu.

 A pop-up opens when a call is incoming.

- Accept call: Tilt Multi-Controller 1 to the right.
- Reject call: Tilt Multi-Controller 1 to the left.
- End call: Tilt Multi-Controller 1 to the left.

Muting

During active phone calls, the microphone in the helmet can be muted.

Phone calls with multiple participants

While a phone call is in progress, a second call can be accepted. The first phone call is put on hold. The number of active calls is shown in the Telephone menu. It is possible to switch between two phone calls.

Telephone data

Depending on the mobile device, when pairing (►► 113) completes telephone data are automatically sent to the vehicle.

Phone book: List of contacts saved on the mobile device

Call list: List of calls with the mobile device

Favourites: List of favourites saved on the mobile device

124 TFT DISPLAY

FAVOURITES BUTTONS

Operating favourites buttons



Individual functions can be assigned to the favourites buttons.

- Light pressure on a button.
 - » The function assigned to the button is shown on the TFT display.
- Firm pressure on a button.
 - » The function assigned to the button is performed.

Assigning functions

- Navigate to Settings, System settings, Favourite button.
- Select a favourites button from Favourite button 1 to Favourite button 4.
- Select the desired function or Not assigned.
 - » The function is assigned to the selected favourites button.

DISPLAY SOFTWARE VERSION

- Navigate to Settings, Information, Software version.

DISPLAY LICENCE INFORMATION

- Navigate to Settings, Information, Licences.

AUDIO SYSTEM

06

RADIO	128
AUDIO SETTINGS	130
PLAYER	132
SATELLITE RADIO	132
HD RADIO EMPFANG	134
IN-HELMET AUDIO PLAYBACK	135

128 AUDIO SYSTEM

RADIO

Starting

- Switch on the ignition (➡ 64).

 The radio menu becomes available shortly after the ignition is switched on.

Switching radio on and off



- Call up the Radio menu and switch Radio on or off.
» When the radio is switched off, Radio off appears in the bottom status line.

Selecting source

- without Canada export^{NV}
 - Call up the Source menu. Select Favourites, AM, FM or DAB (might not be available, depending on country).◀
- with Canada export^{NV}
 - Select the Source menu. Select Favourites, AM, FM or SiriusXM. For the AM and FM wavebands you have the option of selecting HD Radio (might not be available, depending on country).◀

Selecting station

- without Canada export^{NV}
 - Select the source (➡ 128).
 - Select the FM station menu.
 There is a corresponding transmitter menu for each selectable source.◀

- with Canada export^{NV}
 - Select the source (➡ 128).
 - Select the FM station menu.
 There is a corresponding transmitter menu for each selectable source.
 -  HD Radio stations: several program streams selectable via the stations list.◀



- Turn Multi-Controller **1** in direction **A** or direction **B** to browse through the stations.
- Push the Multi-Controller to the right to select the station you want.

Selecting frequency

- without Canada export^{NV}
 - Call up the Source menu and select AM or FM.
 - In the AM options or FM options menu, go to Search selection and select the Frequency setting.
 - Switch to the player.◀

–with Canada export^{NV}

- Call up the *Source* menu and select *AM* or *FM*.
- In the *AM* options or *FM* options menu, go to *Search* selection and select the *Frequency* setting.
- Switch to the player.

 **HD Radio stations:** several program streams selectable within a frequency range.◁

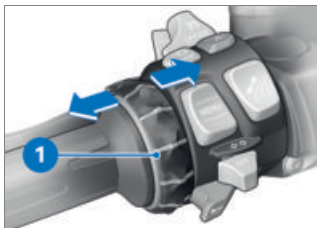

- Push Multi-Controller **1** to the left or right to select the frequency you want in the wave-band.

Save the station

- Select a station or frequency from the frequency band.
- Push the Multi-Controller to the right.
 - » The stations list is opened.

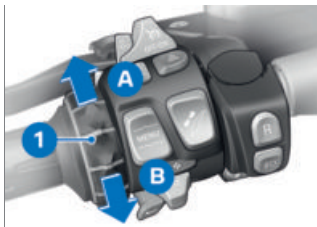

- Turn Multi-Controller **1** in direction **A** or **B** to select the memory slot of your choice.
 - » The current assignment of this memory slot appears on the display.
 - » If a station has already been assigned to the memory slot you select, a message to this effect appears on the display. Your choices are as follows:
 - Select *Cancel* if you do not want to save the station you selected.
 - Select *Save* to overwrite the contents of the memory slot.
 - » The list of channels is reopened.

Favourites list

Selected stations or frequencies can be saved as favourites. Up to 20 favourites can be saved.

There are two ways of adding favourites to the list:

130 AUDIO SYSTEM

Variant 1

- Select the station (▣▣▣ 128).
- Select **Add to Favourites**.
 - » The station selected before-hand appears in the favourites list.
- Push the Multi-Controller to the right.
 - » The station you selected has been saved as a favourite.

Variant 2

- Select the station (▣▣▣ 128).
- Push the Multi-Controller to the right again.
 - » The favourites list opens.
- Push the Multi-Controller to the right again.
 - » The station you selected has been saved as a favourite.
 - » The view automatically returns to the stations list.

Deleting favourites list

Requirement

A favourites list with at least one entry exists.

- Select **Delete Favourites list** at the bottom of the favourites list.
 - » A dialogue opens.
- Confirm deletion.
 - » The favourites list is deleted.

AUDIO SETTINGS

Speakers and Bluetooth

Audio playback is via the on-board speakers, a Bluetooth-paired output device, or the speakers in the helmet. If the Bluetooth function is not available in a particular country, only audio playback via the speakers is available.

When a BMW Motorrad communication system with Bluetooth standard 2.0 or higher is paired, the Multi-Controller can be used to control volume (▣▣▣ 135). If devices that do not support Bluetooth standard 2.0 or higher are paired, the Multi-Controller cannot be used to control volume.

Adjusting volume

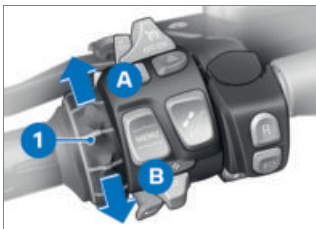

- Turn Multi-Controller **1** in direction **A** to increase volume.
- Turn Multi-Controller **1** in direction **B** to reduce volume.

- » Volume is adjusted automatically for the selected output device.

Selecting output device

- Navigate to **Media, Audio settings** and select **Output device**.
- » The following settings are available:
 - Loudspeakers: **Speakers** selected for audio playback.
 - Helmet: **Helmet** or other **Bluetooth-enabled output device** selected for audio playback.
- » The default setting is **Loudspeakers**.

Selecting sound profile

- Navigate to **Radio, Audio settings** and select **Sound profile**.
- » The following settings are available:
 - Bass-Boost
 - Treble-Boost
 - Voice
 - Studio
 - Balanced
- » The default setting is **Bass-Boost**. All sound profiles have an effect only when **Loudspeakers** is selected.
- » For an optimum sound experience without in-helmet playback, select the **Studio** sound profile. All other sound

profiles are optimised for in-helmet playback.

Adjusting sound settings

- Navigate to **Radio, Audio settings** and select **Equaliser**.
- » The following settings are available:
 - Treble: Reduce (-1...-5) or increase (+1...+5) treble
 - Bass: Reduce (-1...-5) or increase (+1...+5) bass
 - Volume equalisation: Switch off speed-dependent volume boost (1) or select a boost level (2...4).
- Select the menu item you want, select the setting of your choice and exit the menu.
- » The sound settings have an effect only when **Loudspeakers** is selected as the output device.

Volume and speed

The audio system can automatically adapt the volume to the speed of the motorcycle. The rate at which the volume increases in relation to vehicle speed can be set in four stages. Level 4 corresponds to the biggest boost. Selecting level 1 switches speed-dependent volume boost off.

132 AUDIO SYSTEM

Automatic speed-dependent volume adjustment works only when **Loudspeakers** is selected as the output device.

PLAYER

Status indicators on the display

The following information (country-specific) can be shown on the TFT display:

- Selected source (▶▶▶ 128).
- Station (▶▶▶ 128).
- Frequency
- Artist
- Track
- Waveband

Changing station or frequency Requirement

Selecting a frequency is possible only in the **AM** or **FM** waveband and **Frequency** only when the appropriate item has been selected in the options.

- Select the source (▶▶▶ 128).
- Push the Multi-Controller to the right to left select the station or the frequency you want.

 To change the frequency, navigate to **AM options** or **FM options** and select **Frequency** from the menu.

SATELLITE RADIO

-with Canada export^{NV}

Availability

The functions for reception of satellite radio described in this section are available only in countries in which reception of **SiriusXM** is possible.

Subscribing to channel

You have to subscribe to a channel in order to listen to it. Subscribing to a channel can result in costs that are not borne by BMW Motorrad. For information on the available channels go to **siriusxm.com**.

Activation of channels

To activate a channel, call 1-888-539-7474. The **Radio ID** is also required.

Calling up information

Navigate to **Radio**, **SiriusXM** information to view the following list entry:

Radio ID: XXXXXXXXXXXX

For support, please contact **SiriusXM** Customer Care at: 1-888-539-7474

Signal strength

If the signal is not strong enough, **SiriusXM No signal** appears on the display.

Selecting category and channel

- If you want to change the category, navigate to **SiriusXM** station and select **Cat-** **egory**.
 - » The choices at your disposal are as follows:
 - All categories: Shows all subscribed channels
 - Category: E.g. Rock
 - Stations not inc.: Shows all not subscribed channels
- Select the channel of your choice.



- Turn Multi-Controller **1** in direction **A** or **B** to select the channel of your choice from the selected category.

Saving channel

- Select the category and channel (☰ 133).
- Push the Multi-Controller to the right to select a channel.
- Push the Multi-Controller to the right again and select **Add to Favourites**.
 - » The favourites list is opened.

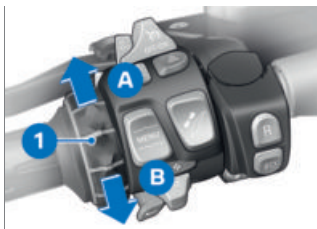

- Turn Multi-Controller **1** in direction **A** or **B** to select the memory slot of your choice.
 - » The current assignment of this memory slot appears on the display.
 - » If a station has already been assigned to the memory slot you select, a message to this effect appears on the display. Your choices are as follows:
 - Select **Cancel** if you do not want to save the station you selected.
 - Select **Save** to overwrite the contents of the memory slot.

134 AUDIO SYSTEM

- » The favourites list closes automatically and the display returns to the preceding view.

Calling up channel saved in memory

Requirement

The selected **Source** has to be **Favourites**.

- Select **Favourites**.
- » The favourites list appears on the display.
- Push the Multi-Controller to the right to select the channel you want.

System messages

Under appropriate circumstances, the following messages appear on the display:

SiriusXM Subscription updated.
Updating subscription.

SiriusXM Channel not subscribed.
No subscription to this channel.

SiriusXM No signal.
SiriusXM service interrupted because of a poor signal.

HD RADIO EMPFANG

–with Canada export^{NV}

The signal strength of HD Radio stations can vary from place to place. If the digital signal is not strong enough, the system automatically switches to reception of the analog signal. A short interruption in reception might occur as the changeover takes place. If AM is selected as the source, audio quality might be perceptibly poorer after this changeover. As soon as the digital signal is available again, reception automatically returns to the HD Radio station.

IN-HELMET AUDIO PLAYBACK

Rider's helmet paired



If a rider's helmet with BMW Motorrad communication system with Bluetooth standard 2.0 is paired:

- The volume of playback via the in-helmet speakers can be set directly using Multi-Controller **1**.
- Any change in helmet volume is shown on the display.

The volume for helmet 2 cannot be adjusted using the Multi-Controller.

ADJUSTMENT

07

MIRRORS	138
WINDSCREEN	138
CLUTCH	139
BRAKES	139

138 ADJUSTMENT

MIRRORS

Adjusting mirrors



- Pivot the mirror to the correct position by pressing gently at the edge.

WINDSCREEN

Adjusting windscreen

- Switch on the ignition (▣▣▣▣ 64).
- » As you ride off, the windscreen automatically moves to its last position before the ignition was switched off.



- Press top section of button **1** to raise the windscreen.
- Press bottom section of button **1** to lower the windscreen.

- Switch off the ignition (▣▣▣▣ 65).
 - » The windscreen automatically moves to the bottom end position.
 - Make sure that nothing obstructs the windscreen's freedom of movement.
- The windscreen does not automatically move to the bottom end position:
- Switch on the ignition (▣▣▣▣ 64).
 - Press button **1** to move the windscreen to its top and bottom end positions.
 - Switch off the ignition (▣▣▣▣ 65).
 - » The windscreen's range of adjustment is calibrated.
 - » Windscreen does not react when button **1** is pressed.
 - Consult a specialist workshop, preferably an authorised BMW Motorrad retailer.

Correct anti-trap mechanism functionality cannot be guaranteed if a windscreen has been installed that has not been approved by BMW Motorrad.

- Under these circumstances: Before switching off the ignition, make sure that nothing obstructs the windscreen's freedom of movement.

CLUTCH

Adjusting clutch lever



WARNING

Changed clutch-fluid reservoir position

Air in the clutch system

- Do not twist the handlebar operating element.



WARNING

Adjusting the clutch lever while riding

Risk of accident

- Adjust the clutch lever only when the motorcycle is at a standstill.

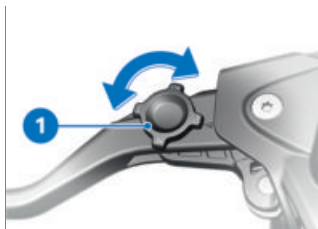

- Turn adjuster knob **1** to the desired position.

 The adjuster is easier to turn if you push the clutch lever forward.

» Adjustment options:

- Position 1: Narrowest span between handlebar grip and clutch lever
- Position 4: Widest span between handlebar grip and clutch lever

BRAKES

Adjusting handbrake lever



WARNING

Changed position of the brake fluid reservoir

Air in the brake system

- Do not turn the handlebar fitting on the handlebar.



WARNING

Adjusting the handbrake lever while riding

Risk of accident

- Do not attempt to adjust the handbrake lever unless the motorcycle is at a standstill.

140 ADJUSTMENT

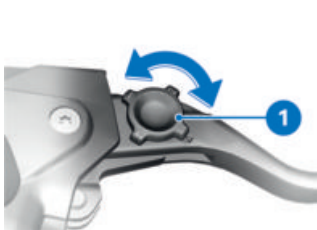

- Turn adjuster knob **1** to the desired position.

 The adjuster is easier to turn if you push the brake lever forward.

» Adjustment options:

- Position 1: Narrowest span between handlebar grip and handbrake lever
- Position 4: Widest span between handlebar grip and handbrake lever

RIDING

08

SAFETY INFORMATION	144
REGULAR CHECK	147
STARTING	147
RUNNING IN	150
SHIFTING GEAR	151
BRAKES	151
PARKING YOUR MOTORCYCLE	154
REFUELLING	155
SECURING MOTORCYCLE FOR TRANSPORTATION	160

SAFETY INFORMATION

Rider's equipment

Do not ride without the correct clothing! Always wear

- Helmet
- Suit
- Gloves
- Boots

This applies even to short journeys, and to every season of the year. Your authorised BMW Motorrad retailer will be happy to advise you on the correct clothing for every purpose.



ATTENTION

Use of non-colour-fast materials (e.g. blue jeans) on the seat

Discolouration on the seat

- Avoid contact with non-colour-fast materials.



WARNING

Loose textiles, items of luggage or straps snagged by open rotating parts of the vehicle (wheels, drive shaft)

Risk of accident

- Make sure that loosely worn or carried textiles cannot be snagged by openly rotating parts of the vehicle.
- Keep all items of luggage and straps well clear of openly rotating parts of the vehicle.

Loading correctly



WARNING

Handling adversely affected by overloading and imbalanced loads

Risk of falling

- Do not exceed the permissible gross weight and be sure to comply with the instructions on loading.
- Make sure that the weight is uniformly distributed between right and left.
- Pack heavy items at the bottom and toward the inboard side.
- Note the maximum permissible payload and maximum

permissible speed with cases fitted, see also the section entitled "Operation".

Speed

If you ride at high speed, always bear in mind that various boundary conditions can adversely affect the handling of your motorcycle:

- Imbalanced load
- Loose clothing
- Insufficient tyre pressure
- Poor tyre tread
- Etc.

-with footboard^{OE}

Footboard

There is no footbrake lever on the footboard!

For information about the partially integral brakes, see the section entitled "Engineering details" (164).



Only the handbrake lever can be used to apply the brakes, so comply with the maximum speed for riding with footboards fitted to the vehicle.



Top speed

max 180 km/h (Maximum speed for journeys with footboard)

Risk of poisoning

Exhaust fumes contain carbon monoxide, which is colourless and odourless but highly toxic.



WARNING

Exhaust gases adversely affecting health

Risk of asphyxiation

- Do not inhale exhaust fumes.
- Do not run the engine in an enclosed space.



WARNING

Inhalation of harmful vapours

Health hazard

- Do not inhale vapours from operating fluid and plastics.
- Use the vehicle only outdoors.

Risk of burning



CAUTION

Engine and exhaust system become very hot when the vehicle is in use

Risk of burn injury

- When you park the vehicle make sure that no-one and no objects can come into contact with the hot engine and exhaust system.



WARNING

Opening radiator cap

Risk of burning

- Do not open the radiator cap when the system is hot.
- Check and, if necessary, top up the coolant in the expansion tank only.

Catalytic converter

If misfiring causes unburned fuel to enter the catalytic converter, there is a danger of overheating and damage.

The following guidelines must be observed:

- Do not run the fuel tank dry.
- Do not attempt to start or run the engine with a spark-plug cap disconnected.
- Stop the engine immediately if it misfires.

- Use only unleaded fuel.
- Comply with all specified maintenance intervals.



ATTENTION

Unburned fuel in catalytic converter

Damage to catalytic converter

- Note the points listed for protection of the catalytic converter.

Risk of overheating



ATTENTION

Engine running for prolonged period with vehicle at standstill

Overheating due to insufficient cooling; in extreme cases vehicle fire

- Do not allow the engine to idle unnecessarily.
- Ride away immediately after starting the engine.

Manipulation



ATTENTION

Tampering with the motorcycle (e.g. engine management ECU, throttle valves, clutch)

Damage to the affected parts, failure of safety-relevant functions, voiding of warranty

- Do not tamper with the vehicle in any way that could result in tuned performance.

REGULAR CHECK

Comply with checklist

At regular intervals, use the checklist below to check your motorcycle.

Always before riding off

- Check operation of the brake system (▣▣▣ 184).
- Check operation of the lights and signalling equipment.
- Check operation of the clutch (▣▣▣ 189).
- Check the tyre tread depth (▣▣▣ 191).
- Check the tyre pressures (▣▣▣ 190).
- Check security of luggage.

Every 3rd refuelling stop

- Check the engine oil level (▣▣▣ 182).
- Check the brake pad thickness, front brakes (▣▣▣ 184).
- Check the brake pad thickness, rear brakes (▣▣▣ 185).
- Check the brake-fluid level, front brakes (▣▣▣ 186).
- Check the brake-fluid level, rear brakes (▣▣▣ 188).

STARTING

Starting engine

- Switch on the ignition (▣▣▣ 64).
 - » Pre-Ride-Check is performed. (▣▣▣ 148)
 - » ABS self-diagnosis is in progress. (▣▣▣ 148)
 - » DTC self-diagnosis is in progress. (▣▣▣ 149)
 - Select neutral or, if a gear is engaged, pull the clutch lever.
-  You cannot start the motorcycle with the side stand extended and a gear engaged. The engine will switch itself off if you start it with the gearbox in neutral and then engage a gear before retracting the side stand.
- Cold starts and low temperatures: Pull the clutch lever and turn the throttle grip to open the throttle slightly.



- Press starter button **1**.

 The start attempt is automatically interrupted if battery voltage is too low. Recharge the battery before you start the engine, or use jump leads and a donor battery to start.

See the subsection on jump starting in "Maintenance" for more details.

- » The engine starts.
- » Consult the troubleshooting chart below if the engine refuses to start. (▣▶ 220)

Pre-Ride-Check

The instrument cluster runs a test of the instruments and the indicator and warning lights when the ignition is switched on. This test is known as the Pre-Ride-Check. The test is aborted if you start the engine before it completes.

Phase 1

All indicator and warning lights are switched on.

After a longer vehicle stand-still period, an animation is displayed when the system starts up.

Phase 2

The 'General' warning light changes from red to yellow.

Phase 3

All the indicator and warning lights switched on in the initial phase are switched off in reverse sequence.

The malfunction indicator lamp (MIL) does not go out until 15 seconds have elapsed.

If one of the indicator and warning lights did not switch on:

- Have the fault rectified as quickly as possible by a specialist workshop, preferably an authorised BMW Motorrad retailer.

ABS self-diagnosis

BMW Motorrad Integral ABS Pro performs self-diagnosis to ensure its operability. Self-diagnosis starts automatically when you switch on the ignition.

Phase 1

- » Test of the diagnosis-compatible system components with the vehicle at a standstill.



flashes.

Phase 2

- » Test of the wheel-speed sensors as the vehicle pulls away from rest.



flashes.

ABS self-diagnosis completed

- » The ABS indicator and warning light goes out.



ABS self-diagnosis not completed

The ABS function is not available, because self-diagnosis did not complete. (The motorcycle has to reach a defined minimum speed with the engine running for the wheel sensors to be checked: min 5 km/h)

If an indicator showing an ABS fault appears when ABS self-diagnosis completes:

- You can continue to ride. Bear in mind that neither the ABS function nor the integral braking function is available.
- Have the fault rectified as quickly as possible by a spe-

cialist workshop, preferably an authorised BMW Motorrad retailer.

DTC self-diagnosis

BMW Motorrad DTC performs self-diagnosis to ensure its operability. Self-diagnosis is performed automatically when you switch on the ignition.

Phase 1

- » Test of the diagnosable system components with the vehicle at a standstill.



slow-flashes.

Phase 2

- » Pullaway test of the system components with diagnostic capability.



slow-flashes.

DTC self-diagnosis completed

- » The DTC symbol no longer shows.
- Observe all the indicator and warning lights.

150 RIDING



DTC self-diagnosis not completed

The DTC function is not available, because self-diagnosis did not complete. (The motorcycle has to reach a defined minimum speed with the engine running for the wheel sensors to be checked: min 5 km/h)

If an indicator showing a DTC fault appears when DTC self-diagnosis completes:

- You can continue to ride. Bear in mind that the DTC function is not available or the functionality might be subject to certain restrictions.
- Have the fault rectified as quickly as possible by a specialist workshop, preferably an authorised BMW Motorrad retailer.

RUNNING IN

Engine

- Until the running-in check, vary the throttle opening and engine-speed range frequently; avoid riding at constant engine rpm for prolonged periods.
- Try to do most of your riding during this initial period on twisting, fairly hilly roads.

- Comply with the running-in speeds.



Running-in speed

<5000 min⁻¹ (Odometer reading 0...300 km)

<6500 min⁻¹ (Odometer reading 300...1000 km)

no full load (Odometer reading 0...1000 km)

- Note the mileage after which the running-in check should be carried out.



Running-in check

500...1200 km

Brake pads

New brake pads have to bed down before they can achieve their optimum friction levels. You can compensate for this initial reduction in braking efficiency by exerting greater pressure on the levers.



WARNING

New brake pads

Longer stopping distance, risk of accident

- Apply the brakes in good time.

Tyres

New tyres have a smooth surface. This must be roughened by riding in a restrained manner at various heel angles until the tyres are run in. This running in procedure is essential if the tyres are to achieve maximum grip.



WARNING

New tyres losing grip on wet roads and at extreme bank angles

Risk of accident

- Ride carefully and avoid extremely sharp inclines.

SHIFTING GEAR

–with shift assistant Pro^{OE}

Gear Shift Assistant Pro



See the section entitled "Engineering details" for more information on Gear Shift Assistant Pro.

- You select the gear in the usual way by means of the foot-operated shift lever.
- » A sensor on the gearshift shaft registers the gearshift request and triggers shift assistance.
- » When riding at a steady speed in a low gear at high engine rpm, an attempt to

shift gear without pulling the clutch can cause a severe load-change reaction. BMW Motorrad recommends disengaging the clutch for shifts in these circumstances. It is advisable to avoid using the shift assistant at engine speeds close to the limits at which the governor cuts in to limit engine rpm.

- » Shift assistance is not available in the following situations:
 - Clutch pulled.
 - Gearshift lever not in its initial position.
 - Upshifts with the throttle valve closed (engine overrun) and when slowing.
 - Downshifts with throttle valve open and when accelerating.
 - After a gearshift, the shift lever has to be fully released before another gearshift with the shift assistant can take place.

BRAKES

How can stopping distance be minimised?

Each time the brakes are applied, a load distribution shift takes place with the load shifting forward from the rear to the front wheel. The sharper the motorcycle decelerates,

152 RIDING

the more load is shifted to the front wheel. The higher the wheel load, the more braking force can be transmitted without the wheel locking. To optimise stopping distance, apply the front brakes rapidly and keep on increasing the force you apply to the brake lever. This makes the best possible use of the dynamic increase in load at the front wheel. Remember to pull the clutch at the same time. In the "emergency braking situations" that are trained so frequently, braking force is applied as rapidly as possible and with the rider's full force applied to the brake levers; under these circumstances the dynamic shift in load distribution cannot keep pace with the increase in deceleration and the tyres cannot transmit the full braking force to the surface of the road. BMW Motorrad Integral ABS prevents the front wheel from locking up.



WARNING

Rear wheel lift due to severe braking

Risk of falling

- When you brake sharply, bear in mind that ABS control cannot always be relied on to prevent the rear wheel from lifting clear of the ground.

Emergency braking

If you brake sharply from a speed in excess of 50 km/h, the brake light flashes rapidly as a warning for road users behind you.

If you brake until your speed is less than 15 km/h, the hazard warning lights start to flash as well. The hazard warning lights switch off automatically as soon as you start to accelerate and vehicle speed reaches 20 km/h.

Descending mountain passes



WARNING

Braking only with the rear brake on mountain descents.

Brake fade. Destruction of the brakes due to overheating.

- Use the front brake and utilise engine braking.



DANGER

Riding with overheated brakes

Risk of accident due to failure of brakes

- Adapt your riding style accordingly.
- Avoid frequent braking by using the engine brake.



WARNING

Failure to observe service intervals

Risk of accident

- Observe the valid service intervals for brakes.

Wet and dirty brakes

Wetness and dirt on the brake discs and the brake pads diminish braking efficiency. Delayed braking action or poor braking efficiency must be reckoned with in the following situations:

- Riding in the rain or through puddles of water.
- After the motorcycle has been washed.
- Riding on salted or gritted roads.
- After work has been carried on the brakes, due to traces of oil or grease.
- Riding on dirt-covered surfaces or off-road.



WARNING

Wetness and dirt result in diminished braking efficiency

Risk of accident

- Apply the brakes lightly while riding to remove wetness and dirt, or dismount and clean the brakes.
- Think ahead and brake in good time until full braking efficiency is restored.

154 RIDING

ABS Pro

Physical limits applicable to motorcycling

WARNING

Braking when cornering

Risk of crash despite ABS Pro

- Invariably, it remains the rider's responsibility to adapt riding style to riding conditions.
- Do not take risks that would negate the additional safety offered by this system.

ABS Pro is available in all riding modes.

Possibility of a fall not precluded

Although ABS Pro provides the rider with valuable assistance and constitutes a huge advance in safety for braking with the motorcycle banked for cornering, it cannot under any circumstances be considered as re-defining the physical limits that apply to motorcycling. It is still possible for these limits to be overshoot due to misjudgement or rider error. In extreme cases this can result in a crash.

Use on public roads

ABS Pro helps make the motorcycle even safer for riding on public roads. When the brakes are applied because of an unforeseen hazard when the motorcycle is banked for cornering, within the physical limits that apply to motorcycling the ABS Pro system prevents the wheels from locking and skidding away.



ABS Pro was not developed to enhance individual braking performance with the motorcycle banked into corners.

PARKING YOUR MOTORCYCLE

Side stand

- Switch off the engine.

ATTENTION

Poor ground underneath the stand

Risk of damage to parts if vehicle topples

- Always check that the ground under the stand is level and firm.
- Extend the side stand and prop the motorcycle on the stand.

**ATTENTION****Additional weight placing strain on the side stand**

Risk of damage to parts if vehicle topples

- Do not sit or lean on the vehicle while it is propped on the side stand.

- If the camber of the roadway permits, turn the handlebars all the way to the left.
- On a gradient, the motorcycle should always face uphill; select 1st gear.

Centre stand

—with centre stand^{OE}

- Switch off the engine.

**ATTENTION****Poor ground underneath the stand**

Risk of damage to parts if vehicle topples

- Always check that the ground under the stand is level and firm.

**ATTENTION****Centre stand retracts due to severe movements**

Risk of damage to parts if vehicle topples

- Do not lean or sit on the vehicle with the centre stand extended.

- Extend the centre stand and lift the motorcycle on to the stand.
- On a gradient, the motorcycle should always face uphill; select 1st gear.

REFUELLING**Fuel grade****Requirement**

For optimum fuel consumption, fuel should be sulphur-free or as low-sulphur as possible.

**ATTENTION****Engine operation with leaded fuel**



Damage to catalytic converter



- Do not attempt to run the vehicle on leaded fuel or fuel with metallic additives (e.g. manganese or iron).

- Observe the maximum ethanol content of the fuel.

156 RIDING

 Fuel additives clean the fuel injection system and the combustion zone. It is advisable to use fuel additives when the engine is operated with low-grade fuel or if the vehicle is to be out of use for a lengthy period of time. More information is available from your authorised BMW Motorrad retailer.

	Recommended fuel grade
	Premium unleaded (maximum 15 % ethanol, E15)
	95 ROZ/RON 90 AKI

	Alternative fuel grade
	Regular unleaded (power- and consumption-related restrictions)
	(max 15 % ethanol, E10/E15) 91 ROZ/RON 87 AKI

» Look for these symbols on the fuel filler cap and on the fuel pump:



Refuelling



WARNING

Fuel is highly flammable

Risk of fire and explosion

- Do not smoke. Never bring a naked flame near the fuel tank.



WARNING

Escape of fuel due to heat-induced expansion if fuel tank is overfilled

Risk of falling

- Do not overfill the fuel tank.



ATTENTION

Wetting of plastic surfaces by fuel

Damage to the surfaces (surfaces become unsightly or dull)

- Clean plastic surfaces immediately after contact with fuel.

- Make sure the ground is level and firm and place the motorcycle on its stand.

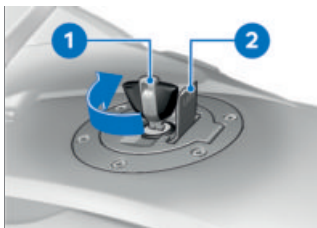

- Open the protective cap **2**.
- Unlock the cap of the fuel tank by turning ignition key **1** clockwise in the lock and pop the cap open.



- Refuel with fuel of the grade stated above; do not fill the tank past the bottom edge of the filler neck.

 When refuelling after running on reserve, make sure that you top up the tank to a level above reserve, so that the new level is detected and the fuel reserve indicator light is switched off.

 The "usable fuel capacity" specified in the technical data is the quantity that the fuel tank could hold if refilled after it had been run dry and the engine had cut out due to a lack of fuel.



Usable fuel capacity

approx. 26.5 l



Reserve fuel

approx. 4 l

- Press the fuel tank cap down firmly to close.
- Remove the ignition key and close the protective cap.

Refuelling

–with Keyless Ride^{OE}

Requirement

The steering lock is disengaged.



WARNING

Fuel is highly flammable

Risk of fire and explosion

- Do not smoke. Never bring a naked flame near the fuel tank.



WARNING

Escape of fuel due to heat-induced expansion if fuel tank is overfilled

Risk of falling

- Do not overfill the fuel tank.



ATTENTION

Wetting of plastic surfaces by fuel

Damage to the surfaces (surfaces become unsightly or dull)

- Clean plastic surfaces immediately after contact with fuel.

- Make sure the ground is level and firm and place the motorcycle on its stand.

–with Keyless Ride^{OE}

- Switch off the ignition (→ 67).



The fuel filler cap can be opened within the defined waiting time after the ignition has been switched off, without the radio-operated key being within range.



Waiting time for opening the fuel filler cap

2 min

- » There are **two variant ways** of opening the fuel filler cap:
 - Within the waiting time.
 - After the waiting time has expired.

Variant 1

Requirement

Within the waiting time

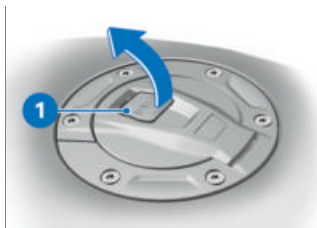

- Slowly pull tab **1** on the fuel filler cap up.
- » Fuel filler cap unlocks.
- Fully open the fuel filler cap.

Variant 2

Requirement

After the waiting time has expired

- Bring the radio-operated key into range.
- Slowly pull tab **1** up.
- » The indicator light for the radio-operated key flashes while the search for the radio-operated key is in progress.
- Slowly pull tab **1** on the fuel filler cap up again.
- » Fuel filler cap unlocks.

- Fully open the fuel filler cap.



- Refuel with fuel of the grade stated above; do not fill the tank past the bottom edge of the filler neck.

 When refuelling after running on reserve, make sure that you top up the tank to a level above reserve, so that the new level is detected and the fuel reserve indicator light is switched off.

 The "usable fuel capacity" specified in the technical data is the quantity that the fuel tank could hold if refilled after it had been run dry and the engine had cut out due to a lack of fuel.



Usable fuel capacity

approx. 26.5 l



Reserve fuel

approx. 4 l

- Press down firmly on the filler cap of the fuel tank.
 - » The fuel filler cap engages with an audible click.
 - » The fuel filler cap locks automatically when the waiting time expires.
 - » The engaged fuel filler cap locks immediately when you secure the steering lock or switch on the ignition.

Opening fuel filler cap emergency release

—with Keyless Ride^{OE}

Fuel filler cap cannot be opened.

- Have the fault rectified as quickly as possible by a specialist workshop, preferably an authorised BMW Motorrad retailer.

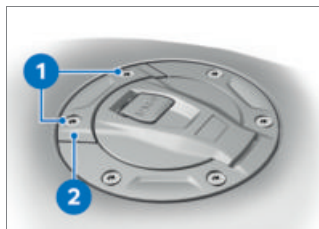

- Remove screws **1**.
- Remove emergency release **2**.
 - » Fuel filler cap unlocks.
- Fully open the fuel filler cap.
- Refuel (➔ 157).

160 RIDING

- Close the fuel filler cap emergency release (▶▶▶ 160).

Closing fuel filler cap emergency release

—with Keyless Ride^{OE}

Requirement

Fuel filler cap is in closed position.

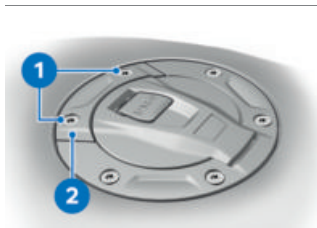

- Hold emergency release **2** in position.
- Install screws **1**.

SECURING MOTORCYCLE FOR TRANSPORTATION

- Make sure that all components that might come into contact with straps used to secure the motorcycle are adequately protected against scratching. Use adhesive tape or soft cloths, for example, for this purpose.



ATTENTION

Vehicle topples to side when being lifted on to stand

Risk of damage to parts if vehicle topples

- Secure the vehicle to prevent it toppling, preferably with the assistance of a second person.
- Push the motorcycle on to the transportation flat and hold it in position: do not place it on the side stand or centre stand.
- Have a helper hold the motorcycle to make sure that it cannot topple.



ATTENTION

Routing of tensioning straps not in compliance with correct procedure

Damage to brake lines, Bowden cables, bearings and trim panels

- Carefully route retaining straps.
 - Use a cloth to protect painted components from scratches.
- Guide the tensioning straps through the front suspension on the left and right and then tighten towards the bottom.
 - At the rear, secure the straps to the rear frame on both sides and tighten the straps.
 - Do not pull the tensioning straps over the footrests.
 - Tighten all the straps uniformly; the vehicle's suspension should be compressed as tightly as possible front and rear.

ENGINEERING DETAILS

09

GENERAL NOTES	164
ANTILOCK BRAKE SYSTEM (ABS)	164
DYNAMIC TRACTION CONTROL (DTC)	168
DYNAMIC ENGINE BRAKE CONTROL	169
ELECTRONIC CHASSIS AND SUSPENSION ADJUST- MENT	170
RIDING MODE	170
TYRE PRESSURE MONITORING (RDC)	172
GEAR SHIFT ASSISTANT	173
HILL START CONTROL	174
ADAPTIVE HEADLIGHT	176

GENERAL NOTES

To find out more about engineering, go to:

bmw-motorrad.com/technik

ANTILOCK BRAKE SYSTEM (ABS)

Partially integral brakes

Your motorcycle is equipped with partially integral brakes. Both front and rear brakes are applied when you pull the handbrake lever. The foot-brake lever acts only on the rear brake.

While the brakes are slowing the motorcycle, the BMW Motorrad Integral ABS adapts braking-force distribution between front and rear brakes to suit the load on the motorcycle.



ATTENTION

Attempted burn-out despite Integral braking function

Damage to rear brake and clutch

- Do not burn out tyres.

How does Integral ABS work?

The amount of braking force that can be transferred to the road depends on factors that include the coefficient of friction of the road surface. Loose stones, ice and snow or a wet road all have much lower coefficients of friction than a clean and dry asphalt surface. The lower the coefficient of friction, the longer the stopping distance.

If the rider increases braking pressure to the extent that braking force exceeds the maximum transferrable limit, the wheels start to lock and the motorcycle loses its directional stability; a fall is imminent. Before this situation can occur, ABS intervenes and adapts braking pressure to the maximum transferable braking force. The wheels continue to turn and the driving stability is retained irrespective of the road condition.

What are the effects of surface irregularities?

Humps and surface irregularities can cause the wheels to lose contact temporarily with the road surface; if this happens the braking force that can be transmitted to

the road can drop to zero. If the brakes are applied under these circumstances the ABS has to reduce braking force to ensure that directional stability is maintained when the wheels regain contact with the road surface. At this instant the BMW Motorrad Integral ABS must assume an extremely low coefficient of friction, so that the wheels will continue to rotate under all imaginable circumstances, because this is the precondition for ensuring directional stability. As soon as it registers the actual circumstances, the system reacts instantly and adjusts braking force accordingly to achieve optimum braking.

What feedback does the rider receive from the BMW Motorrad Integral ABS?

If the ABS system has to reduce braking force on account of the circumstances described above, vibration is perceptible through the handbrake lever. When the handbrake lever is pulled, brake pressure is also built up at the rear wheel by the integral function. If the brake pedal is depressed after the handbrake lever is pulled, the brake pressure built up

beforehand is perceptible as counter-pressure sooner than in the case when the brake pedal is depressed either before or at the same time as the brake lever is pulled.

Rear wheel lift

Under very severe and sudden deceleration, however, under certain circumstances it is possible that the BMW Motorrad Integral ABS will be unable to prevent the rear wheel from lifting clear of the ground. If this happens the outcome can be a highsiding situation in which the motorcycle can flip over.



WARNING

Rear wheel lift due to severe braking

Risk of falling

- When you brake sharply, bear in mind that ABS control cannot always be relied on to prevent the rear wheel from lifting clear of the ground.

166 ENGINEERING DETAILS

What is the design baseline for BMW Motorrad Integral ABS?

Within the limits imposed by physics, the BMW Motorrad ABS ensures directional stability on any surface.

At speeds above min 4 km/h, within the limits imposed by physics the BMW Motorrad ABS can ensure directional stability on any surface. Limitations inherent to the design principle mean that at lower speeds the BMW Motorrad ABS cannot provide optimum assistance on all surfaces.

The system is not optimised for special requirements that apply under extreme competitive conditions off-road or on the track.

Special situations

The speeds of the front and rear wheels are compared as one means of detecting a wheel's incipient tendency to lock. If the system registers implausible values for a lengthy period the ABS function is deactivated for safety reasons and an ABS fault message is issued. Self-diagnosis has to complete before fault messages can be issued.

In addition to problems with the BMW Motorrad Integral ABS, exceptional riding conditions can lead to a fault message being issued.

Exceptional riding conditions:

- Heating up with the motorcycle on the centre stand or an auxiliary stand, engine idling or with a gear engaged.
- Rear wheel locked by the engine brake for a lengthy period, for example while descending on a loose surface.

If a fault message should be triggered due to one of the above-described driving conditions, the ABS function can be re-activated by switching the ignition off and then on again.

What significance devolves on regular maintenance?



WARNING

Brake system not regularly serviced.

Risk of accident

- In order to ensure that the ABS is always maintained in optimum condition, it is essential for you to comply strictly with the specified inspection intervals.

Safety reserves

The potentially shorter braking distances which BMW Motorrad Integral ABS permits must not be used as an excuse for careless riding. The system is primarily a means of ensuring a safety margin in genuine emergencies.



WARNING

Braking when cornering

Risk of accident despite ABS

- Invariably, the rider bears responsibility for assessing road and traffic conditions and adopting his or her style of riding accordingly.
- Do not take risks that would negate the additional margin of safety offered by this system.

Evolution of ABS to ABS Pro

Until now, the BMW Motorrad ABS helped ensure a very high degree of safety for braking with the motorcycle upright and travelling in a straight line. Now ABS Pro offers enhanced safety for braking in corners as well. ABS Pro prevents the wheels from locking even under sharp braking. ABS Pro reduces abrupt changes in steering force, particularly in panic-

braking situations, counteracting the vehicle's otherwise natural but undesirable tendency to straighten up.

ABS intervention

Technically speaking, depending on the riding situation ABS Pro adapts ABS intervention to the motorcycle's bank angle. Signals for rate of roll and rate of yaw and lateral acceleration are used to calculate bank angle. As the motorcycle is heeled over more and more as it banks into a corner, an increasingly strict limit is imposed on the brake-pressure gradient for the start of brake application. This slows the build-up of brake pressure to a corresponding degree. Additionally, pressure modulation is more uniform across the range of ABS intervention.

Advantages for the rider

The advantages of ABS Pro for the rider are sensitive response and high braking and directional stability combined with best-case deceleration of the motorcycle, even when cornering.

DYNAMIC TRACTION CONTROL (DTC)

How does traction control work?

Traction control compares the front and rear wheel circumferential velocities. The differential is used to compute slip as a measure of the reserves of stability available at the rear wheel. If slip exceeds a certain limit, the engine management system intervenes and adapts engine torque accordingly. BMW Motorrad DTC is designed as an assistant system for the rider and for use on public roads. The extent to which the rider affects DTC control can be considerable (weight shifts when cornering, items of luggage loose on the motorcycle), especially when the style of riding takes rider and machine close to the limits imposed by physics. The system is not optimised for special requirements that apply under extreme competitive conditions off-road or on the track. The BMW Motorrad DTC can be deactivated in these cases.



WARNING

Risky riding

Risk of accident despite DTC

- Invariably, the rider bears responsibility for assessing road and traffic conditions and adopting his or her style of riding accordingly.
- Do not take risks that would negate the additional safety offered by this system.

Special situations

In accordance with the laws of physics, the ability to accelerate is restricted more and more as the angle of heel increases. Consequently, there can be a perceptible reduction in acceleration out of very tight bends.

With DTC, the speeds of the front and rear wheels are compared and the angle of heel taken into account as one means of detecting the rear wheel's incipient tendency to spin or slip sideways.

If the lean angle values are identified as implausible over an extended period of time, a substitute value is used for the lean angle or the DTC is switched off. Under these circumstances the indicator for

a DTC fault shows. Self-diagnosis has to complete before fault messages can be issued. The BMW Motorrad traction control may switch off automatically under the exceptional riding conditions outlined below.

Exceptional riding conditions:

- Riding for a lengthy period with the front wheel lifted off the ground (wheelie).
- Rear wheel rotating with the vehicle held stationary by applying the front brake (burn-out).
- Warming up with the motorcycle on the centre stand, in neutral or with a gear engaged.

DYNAMIC ENGINE BRAKE CONTROL

How does dynamic engine brake control work?

The purpose of dynamic engine brake control is to prevent the unstable riding states that can be produced by excessive engine braking moment acting on the rear wheel. Depending on the road condition and riding dynamic, excessive braking torque can produce a sharp rise in rear-wheel slip and impair directional stability.

Dynamic engine brake control limits this slip at the rear wheel to a safe, mode-dependent regulated slip.

Causes for excessive slip at the rear wheel:

- Riding with engine overrun on a surface with a low coefficient of friction (e.g. wet leaves).
- Rear-wheel hop when rider downshifts.
- Sharp braking during sporty riding.

In the same way as BMW Motorrad DTC dynamic traction control, dynamic engine brake control compares the wheel circumferential velocities of the front and rear wheels calculated from the wheel speeds and the tyre radius. Dynamic engine brake control uses this differential to compute slip as a measure of the reserve of stability available at the rear wheel.

If slip overshoots the applicable limit, the throttle valves are opened very slightly to increase engine torque. Slip is reduced and the vehicle is stabilised.

170 ENGINEERING DETAILS

Effect of dynamic engine brake control

- In RAIN and ROAD riding modes: Maximum stability.
- In DYNAMIC riding mode: Compared to RAIN and ROAD riding modes, reduced intervention.

ELECTRONIC CHASSIS AND SUSPENSION ADJUSTMENT

Riding position equaliser

Dynamic ESA is an electronic system that enables your motorcycle's suspension to adjust automatically to suit the load the vehicle is carrying. When spring adjustment is set to *Auto*, the rider does not have to adjust the suspension to suit the load.



BMW Motorrad recommends the *Auto* chassis and suspension setting.

When driving off and when riding, the system monitors the suspension at the rear wheel and corrects the spring setting in order to set the correct riding position. The damping is also adjusted automatically to the load.

By interpreting ride height sensor signals, Dynamic ESA detects movements in the

suspension and responds by adjusting the damper valves. This enables the suspension to adapt to the terrain. Dynamic ESA calibrates itself at regular intervals to ensure the system functions correctly.

Possibilities for adjustment Damping modes

- Road: Normal damping characteristic
- Cruise: Comfortable damping characteristic

Load settings

- Min: Minimum spring setting (only to make the motorcycle easier for the rider to mount)
- Auto: Active ride compensation with automatic adjustment of the spring setting and damping (recommended suspension setting)

RIDING MODE

Selection

To adjust the motorcycle to the road condition and the desired driving experience, the following riding modes can be selected:

- RAIN
- ROAD
- DYNAMIC

For each of these riding modes, there is a matching setting for the DTC system, for dynamic engine brake control and for throttle response.

Dynamic ESA can be parametrised independently of the selected riding mode.

DTC can be switched off in each riding mode. The explanations below always refer to the riding dynamics control systems that are switched on.

Throttle response

- In RAIN riding mode: Gentle throttle response.
- In ROAD riding mode: Optimum throttle response.
- In DYNAMIC riding mode: Direct throttle response.

Traction control DTC

- In RAIN riding mode: Maximum stability on wet roads. Acceleration on dry roads might be reduced.
- In ROAD riding mode: High stability on dry roads. DTC intervenes later than in RAIN riding mode. This prevents the rear wheel from spinning whenever possible.

- In RAIN and ROAD riding modes, the front wheel is prevented from lifting.
- In DYNAMIC riding mode, DTC intervention is later than in RAIN and ROAD riding modes. High performance on dry roads. If road conditions are poor, optimum stability cannot be ensured.

Mode changes

The riding mode can be changed while the vehicle is stationary with the ignition on. Under the following precondition, it is also possible to change modes while riding:

- No drive torque on the rear wheel.
- No brake pressure in the brake system.

The following steps must be taken to change the riding mode:

- Close the throttle twistgrip.
- Release the brake levers.
- Deactivate adaptive cruise control.

The desired riding mode is initially preselected. The mode change does not take place until the systems in question are all in the appropriate state. The selection menu does not disappear from the display until

172 ENGINEERING DETAILS

the mode change has taken place.

TYRE PRESSURE MONITORING (RDC)

Function

A sensor integrated into each tyre measures the air temperature and the air pressure inside the tyre and transmits this information to the control unit. Each sensor has a centrifugal-force tripswitch that does not enable transmission of the measured values until the motorcycle has accelerated to a defined minimum speed for the first time.



Minimum speed for transmission of the RDC measured values:

min 30 km/h

The display shows -- for each tyre until the tyre-pressure signal is received for the first time. The sensors continue to transmit the measured-value signals for some time after the vehicle comes to a stop.



Time for transmission of measured values after vehicle comes to a stop:

min 15 min

An error message is issued if wheels without sensors are fit-

ted to a vehicle equipped with an RDC control unit.

Tyre pressure ranges

The RDC control unit distinguishes between three tyre pressure ranges matched to the vehicle:

- Tyre pressure within permitted tolerance.
- Tyre pressure close to limit of permitted tolerance.
- Tyre pressure outside permitted tolerance.

Temperature compensation

Tyre pressure is a temperature-dependent variable: pressure increases as tyre air temperature rises and decreases as tyre air temperature drops. Tyre-air temperature depends on ambient temperature as well as on the style of riding and the duration of the ride.



The tyre pressures are shown in the TFT display as temperature compensated and always refer to the following tyre air temperature:

20 °C

The air lines available to the public in petrol stations and motorway service areas have gauges that do not compensate for temperature; the reading

shown by a gauge of this nature is the temperature-dependent tyre-air pressure. As a result, the values displayed there usually do not correspond to the values displayed in the display.

Pressure adaptation

Compare the RDC value on the display with the value in the table on the back cover of the rider's manual. Then use the air-line gauge at a service station to compensate for the difference between the RDC reading and the value in the table.

	Example
According to the operating instructions, the tyre pressure should be:	
2.5 bar	
The following display is shown in the TFT display:	
2.3 bar	
So pressure is low by:	
0.2 bar	
The gauge on the air line shows:	
2.4 bar	
You must now increase tyre pressure until the value is:	
2.6 bar	

GEAR SHIFT ASSISTANT

–with shift assistant Pro^{OE}

Gear Shift Assistant Pro

Your vehicle is equipped with G Shift Assistant, a system originally developed for racing and now adapted for the touring sector. It permits upshifts and downshifts without de-clutching or closing the throttle in virtually all load and rpm ranges.

Advantages

- 70-80 % of all gearshifts on a trip can be done without using the clutch.
- Less relative movement between rider and passenger because the shift pauses are shorter.
- It is not necessary to close the throttle valve when shifting under acceleration.
- When braking and downshifting (throttle valve closed), engine speed is adjusted by blipping the throttle.
- Shift time is shorter than a gearshift with clutch actuation.

174 ENGINEERING DETAILS

In order for the system to identify a request for a gearshift, the rider has to move the shift lever from its idle position in the desired direction against the force of the spring through a certain "overtravel" at ordinary speed or rapidly and keep the shift lever in this position until the gearshift is completed. It is not necessary to increase the force applied to the gearshift lever while shifting is in progress. Once the gearshift has completed the shift lever has to be fully released before another gearshift with the Gearshift Assistant Pro can take place. When shifting gears with the Gear Shift Assistant, the rider has to keep load state (throttle twistgrip position) constant before and during the gearshift. A change in the position of the throttle twistgrip during a gearshift can cause the function to abort and/or lead to a missed shift. The shift assistant provides no assistance for the gearshift if the rider declutches.

Downshifting

–Downshifting is assisted until maximum rpm for the target gear to be selected is reached. This prevents over-revving.



Maximum engine speed

max 8500 min⁻¹

Upshifting

–Upshifting is assisted until idle rpm for the target gear to be selected is reached.
–This prevents the engine from dropping below idle speed.



Idle speed

900±50 min⁻¹ (Engine at regular operating temperature)

HILL START CONTROL

Hill Start Control function

Hill Start Control Pro is a pullaway assistant that operates on the partially integral ABS system to prevent the vehicle from rolling back on a gradient, without the rider having to keep pressure applied to the brake lever. When Hill Start Control Pro is activated, pressure is built up in the rear brake system to keep

the machine at a standstill on a gradient.

The brake pressure in the brake system is dependent on the gradient.

Influence of the brake pressure on the riding off behaviour

- If the motorcycle is stopped on a gentle incline, only low brake pressure is built up. In this case, the brakes are quickly released when driving off. The motorcycle can be moved off more gently. It is not necessary to turn the throttle grip again.
- If the motorcycle is stopped on a steep incline, high brake pressure is built up. In this case, the brakes take longer to release when driving off. More torque is required for driving off which also requires the rider to turn the throttle grip again.

Behaviour when the motorcycle rolls or slips

- If the vehicle starts to roll while Hill Start Control Pro is active, brake pressure is increased.
- If the rear wheel slips, the brake is released again after approx. approx. 1 m. This keeps the vehicle from slip-

ping downhill with a locked rear wheel, for example.

Releasing the brake when stopping the engine

Hill Start Control Pro is deactivated if the rider stops the engine by hitting the emergency-off switch (kill switch) or when the side stand is extended. In addition to the indicator and warning lights, the rider should be made aware that Hill Start Control Pro has been deactivated by the following behaviour:

Brake warning jolt

- The brake is released briefly and reactivated immediately.
- This creates a jolt which the rider feels.
- The partial integral ABS brake system limits the speed of movement to approx. 3 km/h.
- The rider must brake the motorcycle manually.
- After two minutes, or when the brake is actuated, Hill Start Control Pro is completely deactivated.



The holding pressure is released immediately without a brake warning jolt as soon as the ignition is switched off.

ADAPTIVE HEADLIGHT

How does the adaptive cornering headlight work?

The low-beam unit installed as standard in the headlight consists of two reflectors that produce a low beam from an LED light source. Ride height sensors on front and rear suspension supply data for permanent beam throw adjustment. While the motorcycle is moving straight ahead, pitch compensation keeps the throw of the headlight beam constantly in the optimum, preset range, regardless of ride and load state. With the Adaptive headlight function, the low-beam unit is additionally rotated about an axis to a degree that varies with the bank angle, compensating for the vehicle's angle of lean. The angle of rotation is $70^\circ (\pm 35^\circ)$. Along with pitch compensation, therefore, the throw of the low-beam headlight also compensates for the rider's chosen bank angle through corners. The two movements are superimposed, so as the motorcycle is steered through a bend the headlight beam is directed into the bend for better illumination of the road ahead. The results

are considerably better illumination of the road ahead when the motorcycle corners, and a huge increase in active riding safety.

MAINTENANCE

10

GENERAL NOTES	180
TOOLKIT	180
FRONT-WHEEL STAND	181
REAR-WHEEL STAND	182
ENGINE OIL	182
BRAKE SYSTEM	184
CLUTCH	189
COOLANT	189
TYRES	190
WHEEL RIMS	191
WHEELS	191
LIGHTING	198
JUMP-STARTING	198
BATTERY	200
FUSES	204
DIAGNOSTIC CONNECTOR	205

180 MAINTENANCE

GENERAL NOTES

The Maintenance chapter describes straightforward procedures for checking and replacing certain wear parts.

Special tightening torques are listed as applicable. The tightening torques for the threaded fasteners on your vehicle are listed in the section entitled "Technical data".

Microencapsulated screws

The microencapsulation is a chemical thread-locker. An adhesive compound creates a secure connection between bolt and nut or between screw and component. Consequently, microencapsulated screws are for once-only use and are not intended for re-installation after being slackened.

After removal of the screw, clean the internal thread to remove all traces of thread-locking compound. Always use new microencapsulated screws when re-assembling. Consequently, prior to disassembly make sure that you have suitable tools for cleaning the threads and a new replacement for each screw to be removed. If the job is not done correctly there is no guaran-

tee that the screw will remain secure, which means that you would be putting yourself at risk!

Some of the work calls for special tools and a thorough knowledge of the technology involved. If you are in doubt, consult a specialist workshop, preferably your authorised BMW Motorrad retailer.

TOOLKIT

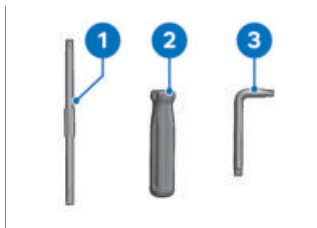

- 1 Reversible screwdriver blade
Slotted bit and Torx T25
- 2 Screwdriver handle
- 3 Torx wrench, T25/T30
T25 on short end, T30 on long end

182 MAINTENANCE

REAR-WHEEL STAND

Installing rear-wheel stand



- The description of how to fit the rear-wheel stand correctly will be found in the instructions for the stand.
- BMW Motorrad offers an auxiliary stand suitable for every vehicle. Your BMW Motorrad retailer will be happy to help you with the selection of a suitable auxiliary stand.

ENGINE OIL

Checking engine oil level

WARNING

Engine oil level low

Risk of accident as a result of a blocked engine

- Always make sure that the oil level is correct.

ATTENTION

Misinterpretation of oil level reading, because oil level is temperature-dependent (the higher the temperature, the higher the oil level)

Engine damage

- Check the oil level only after a lengthy ride or when the engine is at operating temperature.

–with centre stand^{OE}

- Make sure the ground is level and firm and with the engine at operating temperature, place the motorcycle on its centre stand.◀

–without centre stand^{OE}

ATTENTION

Vehicle toppling sideways

Risk of damage to parts if vehicle topples

- Secure the vehicle, preferably with the assistance of a second person, so that it cannot topple sideways.

- Make sure the engine is at operating temperature and hold the motorcycle upright.◀



- Remove oil dipstick **1** and wipe it with a clean, dry cloth.
- Seat the oil dipstick on the oil filler neck, but do not engage the threads.
- Remove the oil dipstick and check the oil level.

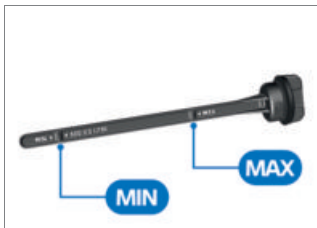

Engine oil, specified level

Between **MIN** and **MAX** marks (Engine at regular operating temperature)



Engine oil, quantity for topping up

max 0.5 l (Difference between **MIN** and **MAX**)

If the oil level is below the **MIN** mark:

- Top up the engine oil (→ 183).

If the oil level is above the **MAX** mark:

- Have the oil level corrected by a specialist workshop, preferably an authorised BMW Motorrad retailer.
- Install the oil dipstick.

Topping up engine oil

- Make sure the ground is level and firm and place the motorcycle on its stand.
- Wipe the area around the filler neck clean.



- Remove oil dipstick **1**.



ATTENTION

Use of insufficient engine oil or too much engine oil

Engine damage

- Always make sure that the oil level is correct.

184 MAINTENANCE

- Top up the engine oil to the specified level.
- Check the engine oil level (▮▮▮▮▶ 182).
- Install oil dipstick **1**.

BRAKE SYSTEM

Checking function of brakes

- Make sure the ground is level and firm and place the motorcycle on its stand.
- Pull the front brake lever.
 - » The pressure point must be clearly perceptible.
- Press the footbrake lever.
 - » The pressure point must be clearly perceptible.

If pressure points are not clearly perceptible:



ATTENTION

Work on brake system not in compliance with correct procedure

Risk to operational reliability of the brake system

- Have all work on the brake system undertaken by trained and qualified specialists.
- Have the brakes checked by a specialist workshop, preferably an authorised BMW Motorrad dealer.

Checking brake pad thickness, front brakes

- Make sure the ground is level and firm and place the motorcycle on its stand.

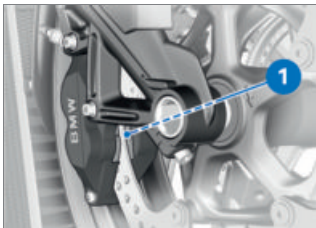

- Visually inspect the left and right brake pads to ascertain their thickness. Viewing direction: Between front suspension and brake caliper mount toward brake pads **1**.

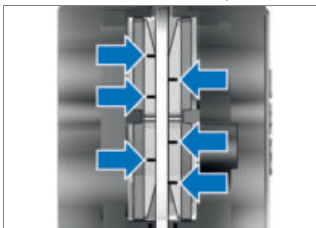

Brake-pad wear limit, front

min 1.0 mm (Friction pad only, without backing plate. The wear indicators (grooves) must be clearly visible.)

If the wear indicating marks are no longer clearly visible:



WARNING

Brake-pad thickness less than permissible minimum

Diminished braking effect, damage to the brakes

- In order to ensure the dependability of the brake system, do not permit the brake pads to wear past the minimum permissible thickness.
- Have the brake pads replaced by a specialist workshop, preferably an authorised BMW Motorrad retailer.

Checking brake pad thickness, rear brakes

- Make sure the ground is level and firm and place the motorcycle on its stand.

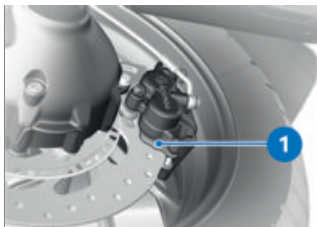

- Visually inspect the brake pads to ascertain their thickness. Viewing direction: From below toward brake pads **1**.

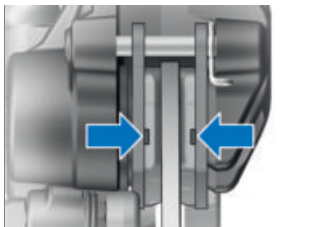

 Brake-pad wear limit, rear

min 1.0 mm (Friction pad only, without backing plate. Do not permit wear to progress to the point at which the wear indicators (grooves) are reached.)

If the wear indicating mark is no longer visible:



WARNING

Brake-pad thickness less than permissible minimum

Diminished braking effect, damage to the brakes

- In order to ensure the dependability of the brake system, do not permit the brake pads to wear past the minimum permissible thickness.
- Have the brake pads replaced by a specialist workshop, preferably an authorised BMW Motorrad retailer.

Checking brake-fluid level, front brakes



WARNING

Not enough brake fluid in brake fluid reservoir, or contaminants in brake fluid

Considerably reduced braking power due to presence of air, contaminants or water in the brake system

- Cease operation of the vehicle immediately and do not ride it until the fault has been rectified.
 - Check the brake-fluid levels at regular intervals.
 - Always make sure that the lid of the brake fluid reservoir and the area around the lid are cleaned before opening.
 - Make sure that only fresh brake fluid from a sealed container is used.
- with centre stand^{OE}
- Make sure the ground is level and firm and place the motorcycle on its centre stand.◁

—without centre stand^{OE}



ATTENTION

Vehicle toppling sideways

Risk of damage to parts if vehicle topples

- Secure the vehicle, preferably with the assistance of a second person, so that it cannot topple sideways.
- Make sure the ground is level and firm and hold the motorcycle upright.◁
- Turn the handlebars to a position in which the brake fluid reservoir is horizontal.



- Check the brake fluid level in brake fluid reservoir for front wheel brake **1**.

 Wear of the brake pads causes the brake fluid level in the reservoir to sink.



Brake fluid level, front

Brake fluid, DOT4

It is not permissible for the brake fluid level to be below the **MIN** mark. (Brake-fluid reservoir horizontal, motorcycle upright and handlebars centred.)

If the brake fluid level drops below the permitted level:

- Have the fault rectified as quickly as possible by a specialist workshop, preferably an authorised BMW Motorrad retailer.

188 MAINTENANCE

Checking brake-fluid level, rear brakes

WARNING

Not enough brake fluid in brake fluid reservoir, or contaminants in brake fluid

Considerably reduced braking power due to presence of air, contaminants or water in the brake system

- Cease operation of the vehicle immediately and do not ride it until the fault has been rectified.
- Check the brake-fluid levels at regular intervals.
- Always make sure that the lid of the brake fluid reservoir and the area around the lid are cleaned before opening.
- Make sure that only fresh brake fluid from a sealed container is used.

—with centre stand^{OE}

- Make sure the ground is level and firm and place the motorcycle on its centre stand.◁

—without centre stand^{OE}

ATTENTION

Vehicle toppling sideways

Risk of damage to parts if vehicle topples

- Secure the vehicle, preferably with the assistance of a second person, so that it cannot topple sideways.
- Make sure the ground is level and firm and hold the motorcycle upright.◁

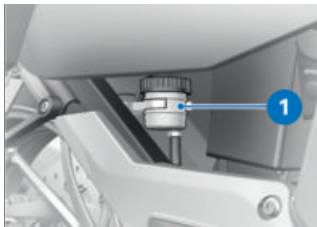

- Check the brake fluid level in brake fluid reservoir for rear wheel brake **1**.

 Wear of the brake pads causes the brake fluid level in the reservoir to sink.



Brake fluid level, rear

Brake fluid, DOT4

It is not permissible for the brake fluid level to be below the **MIN** mark. (Brake-fluid reservoir horizontal, motorcycle upright.)

If the brake fluid level drops below the permitted level:

- Have the fault rectified as quickly as possible by a specialist workshop, preferably an authorised BMW Motorrad retailer.

CLUTCH

Checking clutch function

- Pull the clutch lever.
 - » The pressure point must be clearly perceptible.

If the pressure point is not clearly perceptible:

- Have the clutch checked by a specialist workshop, preferably an authorised BMW Motorrad dealer.

COOLANT

Checking coolant level

- Make sure the ground is level and firm and place the motorcycle on its stand.
- Allow the engine to cool down.



- Check the coolant level in expansion tank **1**.

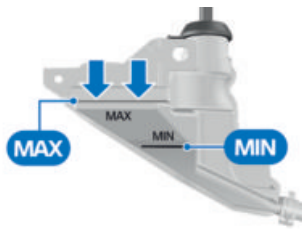

 Specified coolant level

Between **MIN** and **MAX** marks on the expansion tank (Engine cold)

If the coolant drops below the permitted level:

- Have the fault rectified as quickly as possible by a specialist workshop, preferably an authorised BMW Motorrad retailer.

TYRES

Tyre recommendation

For each size of tyre, BMW Motorrad tests and classifies as roadworthy certain makes. BMW Motorrad cannot assess the suitability or provide any guarantee of road safety for other tyres.

BMW Motorrad recommends using only tyres tested by BMW Motorrad.

Detailed information is available from your

authorised BMW Motorrad dealer or in the internet at bmw-motorrad.com/service.

Checking tyre pressures

WARNING

Incorrect tyre pressure

Impaired handling characteristics of the motorcycle, shorter useful tyre life

- Always check that the tyre pressures are correct.

WARNING



Tendency of valve inserts installed vertically to open by themselves at high riding speeds

Sudden loss of tyre pressure

- Install valve caps fitted with rubber sealing rings and tighten firmly.

- Make sure the ground is level and firm and place the motorcycle on its stand.
- Check tyre pressures against the data below.

 Before adjusting tyre pressure, read the information on temperature compensation and adjusting pressure in the section entitled "Engineering details".

	Tyre pressure, front
2.9 bar (tyre cold)	
	Tyre pressure, rear
2.9 bar (tyre cold)	

If tyre pressure is too low:

- Correct tyre pressure.

Checking tyre tread depth



WARNING

Riding with badly worn tyres

Risk of accident due to impaired handling

- If applicable, have the tyres changed in good time before they wear to the minimum tread depth permitted by law.

- Make sure the ground is level and firm and place the motorcycle on its stand.
- Measure the tyre tread depth in the main tread grooves with wear marks.



Wear indicators are built into the main profile grooves on each tyre. The tyre is worn out when the tyre tread has worn down to the level of the marks. The locations of the marks are indicated on the

edge of the tyre, e.g. by the letters TI, TWI or by an arrow.

If the tyre tread is worn to minimum:

- Replace tyre or tyres, as applicable.

WHEEL RIMS

Checking rims

- Make sure the ground is level and firm and place the motorcycle on its stand.
- Visually inspect the rims for defects.
- Have any damaged rims inspected by a specialist workshop and replaced if necessary, preferably by an authorised BMW Motorrad dealer.

WHEELS

Effect of wheel size on chassis and suspension control systems

Wheel size is very important as a parameter for the frame and suspension control systems ABS and DTC. In particular, the diameter and the width of the vehicle's wheels are programmed into the control unit and are fundamental to all calculations. Any change in these influencing variables, caused for example by a switch to wheels other than those installed ex-

192 MAINTENANCE

works, can have serious effects on the performance of the control systems.

The sensor rings are essential for correct wheel speed detection; they too must match the motorcycle's control systems and consequently cannot be replaced.

If you decide that you would like to fit non-standard wheels to your motorcycle, it is very important to consult a specialist workshop beforehand, preferably an authorised BMW Motorrad dealer. In some cases, the data programmed into the control units can be changed to suit the new wheel sizes.

Remove the front wheel

—with centre stand^{OE}

- Make sure the ground is level and firm and place the motorcycle on its centre stand.◀

—without centre stand^{OE}

- Place the motorcycle on an auxiliary stand; BMW Motorrad recommends you use the BMW Motorrad rear-wheel stand.
- Install the rear-wheel stand (▶ 182).◀

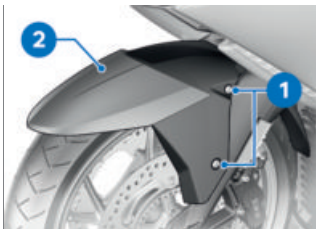

- Remove screws **1** on left and right.
- Pull front-wheel cover **2** forward to remove.



- Disengage the cable for the wheel speed sensor from holding clip **1** and remove cable tie **2**.
- Remove screw **3** and remove the wheel speed sensor from its bore.
- Remove mounting bolts **4** of the left and right brake calipers.



- Force brake pads **1** slightly apart by rocking brake caliper **2** back and forth against brake disc **3**.

**ATTENTION****Use of hard or sharp-edged objects in proximity to component**

Component damage

- Take care not to scratch components; cover or mask as necessary.
- Mask off the parts of the wheel rim that could be scratched in the process of removing the brake calipers.

**ATTENTION****Unwanted inward movement of the brake pads**

Component damage on attempt to install the brake caliper or because brake pads have to be forced apart

- Do not operate the brakes with a brake caliper not correctly secured.
- Carefully pull the brake calipers back and out until clear of the brake discs.
- Raise front of motorcycle until the front wheel can turn freely. Use a suitable front-wheel stand to lift the front of the motorcycle.
- Install the front-wheel stand (👉 181).

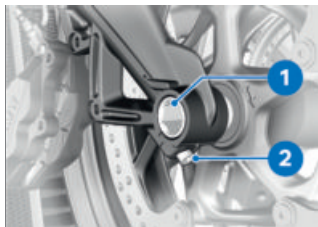

- Undo right axle clamping screw **2**.
- Support the front wheel and remove quick-release axle **1**.

194 MAINTENANCE

- Set down front wheel and roll forwards out of the front suspension.

Installing front wheel

WARNING

Use of a non-standard wheel

Malfunctions in operation of ABS and DTC

- See the information on the effect of wheel size on the ABS and DTC systems at the start of this chapter.

ATTENTION

Tightening threaded fasteners to incorrect tightening torque

Damage, or threaded fasteners work loose

- Always have the security of the fasteners checked by a specialist workshop, preferably an authorised BMW Motorrad dealer.

ATTENTION

Front wheel installed wrong way round

Risk of accident

- Note direction-of-rotation arrows on tyre or rim.

- Roll the front wheel into position between the forks of the front suspension.



- Lubricate quick-release axle **1**.



Lubricant

Optimoly TA

WARNING

Improper installation of the quick-release axle

Loosening of the front wheel

- After securing the brake calipers and relieving the front forks, tighten the quick-release axle and the axle clamping to the specified tightening torque.

- Raise the front wheel, insert quick-release axle **1** and tighten to specified torque.

 Quick-release axle in threaded bush (wheel carrier)

M24 x 1.5

50 Nm

- Tighten right axle clamping screw **2** to specified torque.

 Clamping screw for quick-release axle to wheel carrier

M8 x 30

19 Nm

- Remove the front-wheel stand.
- Position left and right brake calipers on the brake discs.

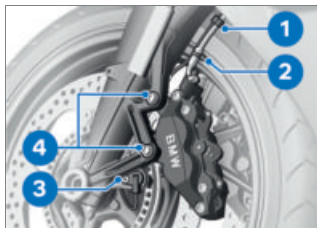

- Install securing screws **4** on left and right and tighten to specified tightening torque.

 Front brake caliper to wheel carrier

M8 x 30 - 10.9

28 Nm

- Remove the adhesive tape from the wheel rim.

 **WARNING**

Brake pads not lying against the brake disc

Risk of accident due to delayed braking effect.

- Before driving, check that the brakes respond without delay.
- Operate the brake several times until the brake pads are bedded.
- Seat the cable for the wheel speed sensor in holding clip **1** and install cable tie **2**.
- Insert the wheel speed sensor into the bore hole and install screw **3**.

 Wheel-speed sensor to front suspension/rear brake caliper

M5 x 10 - 10.9

Thread-locking compound: micro-encapsulated

4.6 Nm

196 MAINTENANCE



- Hold front wheel cover **2** in position and install screws **1** on left and right.



Front-wheel cover to wheel carrier

M6 x 16

Thread-locking compound: micro-encapsulated

2 Nm

Remove the rear wheel

—with centre stand^{OE}

- Make sure the ground is level and firm and place the motorcycle on its centre stand.◁

—without centre stand^{OE}

- Place the motorcycle on an auxiliary stand; BMW Motorrad recommends you use the BMW Motorrad rear-wheel stand.
- Install the rear-wheel stand (▶▶ 182).◁



- Remove screws **1**.
- Swing number plate carrier **2** up.
- Engage first gear.



CAUTION

Hot exhaust system

Risk of burn injury

- Do not touch a hot exhaust system.
- Remove bolts **1** from the rear wheel, while supporting the wheel.
- Roll the rear wheel out toward the rear.

Install the rear wheel

WARNING

Use of a non-standard wheel
Malfunctions in operation of ABS and DTC

- See the information on the effect of wheel size on the ABS and DTC systems at the start of this chapter.

ATTENTION

Tightening threaded fasteners to incorrect tightening torque

Damage, or threaded fasteners work loose

- Always have the security of the fasteners checked by a specialist workshop, preferably an authorised BMW Motorrad dealer.

ATTENTION

Rear wheel installed with tyre's direction of rotation incorrect

Risk of accident

- Note direction-of-rotation arrows on tyre or rim.

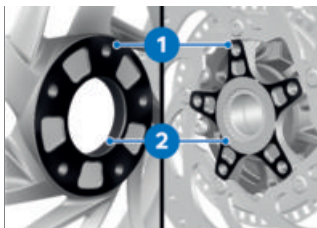

- Clean the contact surfaces of wheel hub **1** and wheel centring spigot **2**.
- Roll the rear wheel to the rear-wheel mounting and position it.



- Install screws **1** and tighten to the specified torque in diagonally opposite sequence.

 Rear wheel to wheel flange

Tightening sequence: tighten in diagonally opposite sequence

M10 x 1.25 x 40

60 Nm

198 MAINTENANCE



- Swing number plate carrier **1** down.
- Install screws **2**.

 Number-plate carrier to rear frame

M6 x 17.5

8 Nm

LIGHTING

Replacing LED light sources

WARNING

Vehicle overlooked in traffic due to failure of the lights on the vehicle

Safety risk

- Always replace a faulty bulb at the earliest possible opportunity. Consult a specialist workshop, preferably an authorised BMW Motorrad Retailer.

All light sources of the vehicle are LED light sources. The service life of the LED light sources is longer than the presumed vehicle service life. If an LED light source is faulty contact a specialist workshop, preferably an authorised BMW Motorrad retailer.

JUMP-STARTING

CAUTION

Touching live parts of the ignition system when the engine is running

Electric shock

- Do not touch parts of the ignition system when the engine is running.

**ATTENTION****Excessive current flowing when the motorcycle is jump-started**

Wiring smoulders/ignites or damage to the on-board electronics

- If the motorcycle has to be jump-started connect the leads to the battery terminals; never attempt to jump-start the engine by connecting leads to the on-board socket.

**ATTENTION****Contact between crocodile clips of jump leads and vehicle**

Risk of short-circuit

- Use jump leads fitted with fully insulated crocodile clips at both ends.

**ATTENTION****Jump-starting with a voltage greater than 12 V**

Damage to the on-board electronics

- Make sure that the battery of the donor vehicle has a voltage rating of 12 V.

- When jump-starting the engine, do not disconnect the battery from the on-board electrical system.
- Remove the seat (▣▣▣ 94).
- Remove the battery cover (▣▣▣ 202).
- Run the engine of the donor vehicle during jump-starting.
- Begin by connecting one end of the red jump lead to the positive terminal of the discharged battery and the other end to the positive terminal of the donor battery.
- Connect one end of the black jump lead to the negative terminal of the donor battery, then connect the other end to the negative terminal of the discharged battery.
- Start the engine of the vehicle with the discharged battery in the usual way; if the engine does not start, wait a few minutes before repeating the attempt in order to protect the starter motor and the donor battery.
- Allow both engines to run for a few minutes before disconnecting the jump leads.
- Disconnect the jump lead from the negative terminal first, then from the positive terminal.

200 MAINTENANCE

- Install the battery cover (👉 202).
- Install the seat (👉 94).

BATTERY

Maintenance instructions

Correct upkeep, recharging and storage will prolong the life of the battery and are essential if warranty claims are to be considered.

Compliance with the points below is important in order to maximise battery life:

- Keep the surface of the battery clean and dry.
- Do not open the battery.
- Do not top up with water.
- Be sure to read and comply with the instructions for charging the battery on the following pages.
- Do not turn the battery upside down.



ATTENTION

On-board electronics (e.g. clock) draining connected battery

Battery is deep-discharged; this voids the guarantee

- Connect a float charger to the battery if the motorcycle is to remain out of use for more than four weeks.



BMW Motorrad has developed a float charger specially designed for compatibility with the electronics of your motorcycle. Using this charger, you can keep the battery charged during long periods of disuse, without having to disconnect the battery from the motorcycle's on-board systems. You can obtain additional information from your authorised BMW Motorrad dealer.

Charging battery when connected



ATTENTION

Charging the battery that is connected to the vehicle via the battery terminals

Damage to the on-board electronics

- Disconnect the battery at the battery terminals before charging.

**ATTENTION****Recharging a fully discharged battery via the power socket or extra socket**

Damage to the vehicle electronics

- If a battery has discharged to the extent that it is completely flat (battery voltage less than 12 V, indicator lights and multifunction display remain off when the ignition is switched on) always charge the **disconnected** battery with the charger connected directly to the battery terminals.

**ATTENTION****Unsuitable chargers connected to a socket**

Damage to charger and vehicle electronics

- Use suitable BMW chargers. The suitable charger is available from your authorised BMW Motorrad dealer.

- With the battery connected to the vehicle's on-board electrical system, charge via the power socket in the cockpit.



The motorcycle's on-board electronics know when the battery is fully charged. The on-board socket is switched off when this happens.

- Comply with the operating instructions of the charger.



If you are unable to charge the battery through the on-board socket, you may be using a charger that is not compatible with your motorcycle's electronics. In this case, directly charge the battery at the terminals of the battery that has been disconnected from the vehicle.

Charging battery when disconnected**ATTENTION****Charging the battery that is connected to the vehicle via the battery terminals**

Damage to the on-board electronics

- Disconnect the battery at the battery terminals before charging.

- Disconnecting battery from motorcycle (➔ 202).
- Charge the battery using a suitable charger.

202 MAINTENANCE

- Comply with the operating instructions of the charger.
- Once the battery is fully charged, disconnect the charger's terminal clips from the battery terminals.

 The battery has to be recharged at regular intervals in the course of a lengthy period of disuse. See the instructions for caring for your battery. Always fully recharge the battery before restoring it to use.

- Connecting battery to motorcycle (▮▮▮ 203).

Removing battery cover

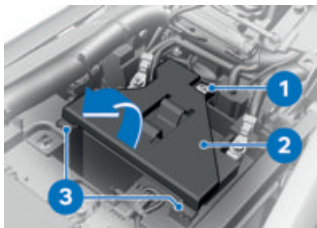

- Remove screw **1**.
- Swing up cover **2**, taking care with the retaining lugs **3**.

Installing battery cover

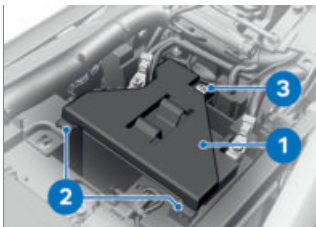

- Fit the cover **1** with the retaining lugs **2**.
- Install screw **3**.

 Battery bracket on rear carrier

M6 x 14.5

8 Nm

Disconnecting battery from motorcycle

- Make sure the ground is level and firm and place the motorcycle on its stand.
- Remove the seat (▮▮▮ 94).
- Remove the battery cover (▮▮▮ 202).

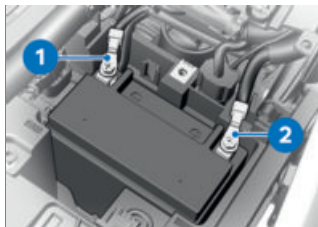
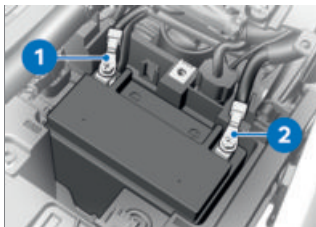

ATTENTION

Battery not disconnected in accordance with correct procedure

Risk of short-circuit

- Always proceed in compliance with the specified disconnection sequence.
- First disconnect negative battery cable **1**.
- Then disconnect positive battery cable **2**.

Connecting battery to motorcycle



ATTENTION

Battery not connected in accordance with correct procedure

Risk of short-circuit

- Always proceed in compliance with specified installation sequence.

- First connect positive battery cable **2**.
- Then connect negative battery cable **1**.
- Install the battery cover (▣▣▣ 202).
- Install the seat (▣▣▣ 94).

Removing battery

- Remove the battery cover (▣▣▣ 202).
- Disconnecting battery from motorcycle (▣▣▣ 202).
–with anti-theft alarm (DWA)^{OE}
- Switch off the anti-theft alarm system.◁
- Switch off the ignition.

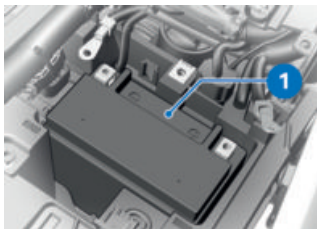

- Lift battery **1** up and out; work it slightly back and forth if it is difficult to remove.

Installing battery

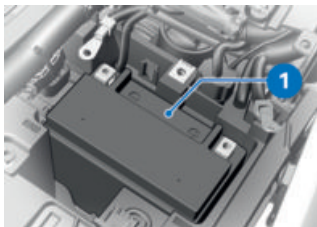

- Insert battery **1** into the battery compartment, positive terminal on the left in the forward direction of travel.

–with anti-theft alarm (DWA)^{OE}

- Switch on the anti-theft alarm.
◁
- Connecting battery to motorcycle (►► 203).
- Install the battery cover (►► 202).
- Set the clock (►► 111).
- Set the date (►► 111).

FUSES

Replacing fuse

- Switch off the ignition (►► 65).
- Remove the seat (►► 94).
- Remove the battery cover (►► 202).

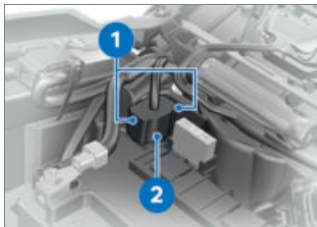

- Press locks **1** on both sides.
- Remove fuse box **2**.



ATTENTION

Jumpering of blown fuses

Risk of short-circuit and fire

- Never attempt to jumper a blown fuse.
 - Always replace a defective fuse with a new fuse of the same amperage.
- Consult the fuse assignment diagram and replace the defective fuse.



If fuse defects recur frequently have the electric circuits checked by a specialist workshop, preferably an authorised BMW Motorrad dealer.

- Re-insert fuse box **2**. Make sure that locks **1** engage on both sides.
- Install the battery cover (▣▣▣ 202).
- Install the seat (▣▣▣ 94).

Fuse assignment

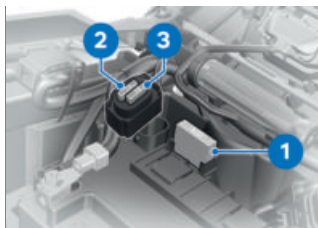

- 1** 40 A
Main fuse
- 2** 7.5 A
Topcase, RDC, sensor box
- 3** 10 A
Instrument cluster, ignition switch, DWA, isolating relay, OBD connector

Fuse for audio system



- 1** 15 A
Fuse for audio system

DIAGNOSTIC CONNECTOR

Disengaging diagnostic socket

CAUTION

Incorrect disconnection of the diagnostic socket for on-board diagnosis

Malfunctions of the vehicle

- Do not disconnect the diagnostic socket or allow it to be disconnected except in the course of a BMW Motorrad service by a specialist workshop or by other authorised persons.
- Have the work carried out by appropriately trained personnel.
- Comply with the stipulations of the vehicle manufacturer.

- Remove the seat (▣▣▣ 94).



- Press locks **1**.
 - Disengage diagnostic socket **2** from seat mount **3**.
- » The interface to the diagnosis and information system can be connected to the diagnostic connector **2**.

Securing diagnostic socket

- Disconnect the interface for the diagnosis and information system.

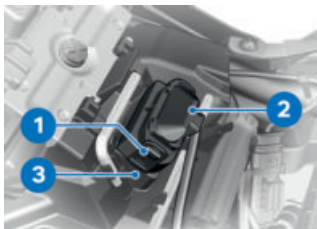

- Insert diagnostic socket **2** into seat mount **3**.
- » The locks **1** engage.
- Install the seat (▣▣▣ 94).

ACCESSORIES

11

GENERAL NOTES	210
POWER SOCKETS	210

GENERAL NOTES



CAUTION

Use of other-make products

Safety risk

- BMW Motorrad cannot examine or test each product of outside origin to ensure that it can be used on or in connection with BMW vehicles without constituting a safety hazard. Country-specific official authorisation does not suffice as assurance. Tests conducted by these instances cannot make provision for all operating conditions experienced by BMW vehicles and, consequently, they are not sufficient in some circumstances.
- Use only parts and accessories approved by BMW for your vehicle.

BMW has conducted extensive testing of the parts and accessory products to establish that they are safe, functional and suitable. Consequently, BMW accepts responsibility for the products. BMW accepts no liability whatsoever for parts and accessories that it has not approved.

All modifications must be in compliance with legal requirements. Make sure that the vehicle does not infringe the national road-vehicle construction and use regulations applicable in your country. Your authorised BMW Motorrad retailer can offer expert advice on the choice of genuine BMW parts, accessories and other products. To find out more about accessories go to: bmw-motorrad.com/equipment.

POWER SOCKETS

Connection of electrical devices

- You can start using electrical devices connected to the motorcycle's sockets only when the ignition is switched on.

Cable routing

- The cables from the power sockets to the auxiliary devices must be routed in such a way that they do not impede the rider.
- The cable routing should not restrict the steering angle or obstruct handling.
- The cables must not be trapped.

Automatic shutdown

- The sockets will be automatically switched off during the start procedure.
- The power supply to the sockets is switched off a certain time after the ignition is switched off, in order to prevent overloading of the on-board electrics. Low-wattage electrical accessories might not be recognised by the vehicle's electronics. In such cases, power sockets are switched off very shortly after the ignition is turned off.

	Automatic shutdown of the sockets after ignition OFF
max 15 min	

- If the battery charge state is too low to maintain the motorcycle's start capability, the power sockets are switched off.
- The power sockets are also switched off when the maximum load capability as stated in the technical data is exceeded.

CARE

12

CARE PRODUCTS	214
WASHING THE VEHICLE	214
CLEANING EASILY DAMAGED COMPONENTS	215
CARE OF PAINTWORK	216
VEHICLE PRESERVATION	217
LAYING UP MOTORCYCLE	217
RESTORING MOTORCYCLE TO USE	217

CARE PRODUCTS

BMW Motorrad recommends that you use the cleaning and care products you can obtain from your authorised BMW Motorrad dealer. The substances in BMW Care Products have been tested in laboratories and in practice; they provide optimised care and protection for the materials used in your vehicle.



ATTENTION

Use of unsuitable cleaning and care products

Damage to vehicle parts

- Do not use solvents such as cellulose thinners, cold cleaners, fuel or the like, and do not use cleaning products that contain alcohol.



ATTENTION

Use of strongly acidic or strongly alkaline cleaning agents

Damage to vehicle parts

- Dilute in accordance with the dilution ratio stated on the packaging of the cleaning agent.
- Do not use strongly acidic or strongly alkaline cleaning agents.

WASHING THE VEHICLE

BMW Motorrad recommends that you use BMW insect remover to soften and wash off insects and stubborn dirt on painted parts prior to washing the vehicle.

To prevent stains, do not wash the vehicle immediately after it has been exposed to strong sunlight and do not wash it in the sun.

Remove dirt from the fork legs at regular intervals.

Make sure that the vehicle is washed frequently, especially during the winter months.

To remove road salt, clean the motorcycle with cold water immediately after every trip.

 After a ride in the rain, when humidity is high or after the vehicle has been washed, condensation might form inside the headlight. This can cause temporary fogging on the headlight lens. If moisture is constantly present inside the headlight consult a specialist workshop, preferably an authorised BMW Motorrad retailer.

 **WARNING**

Wet brake discs and brake pads after vehicle wash, after riding through water and in rainy conditions

Diminished braking effect, risk of accident

- Apply the brakes in good time to allow the friction and heat to dry the brake discs and brake pads.

 **ATTENTION**

Effect of road salt intensified by warm water

Corrosion

- Use only cold water to wash off road salt.

 **ATTENTION**

Damage due to high water pressure from high pressure cleaners or steam cleaners

Corrosion or short circuit, damage to labels, seals, hydraulic brake system, electrical system and the motorcycle seat

- Exercise restraint when using a steam jet or high pressure cleaning equipment.

CLEANING EASILY DAMAGED COMPONENTS

Plastics

 **ATTENTION**

Use of unsuitable cleaning agents

Damage to plastic surfaces

- Do not use cleaning agents that contain alcohol, solvents or abrasives.
- Do not use insect-remover pads or cleaning pads with hard, scouring surfaces.

Clean the plastic parts with water and BMW plastic care product. This includes in particular:

216 CARE

- Windscreen and slipstream deflectors
- Headlight lens made of plastic
- Glass cover of the instrument cluster
- Black, unpainted parts

 Soften stubborn dirt and insects by covering the affected areas with a wet cloth.

TFT display

Clean the TFT display with warm water and washing-up liquid. Then dry it with a clean cloth, e.g. a paper towel.

Chrome

Carefully clean chrome sections with a generous amount of water and motorcycle cleaner from the care series BMW Motorrad Care Products. This applies especially where road salt has been in use. For an additional treatment, use BMW Motorrad metal polish.

Radiator

Clean the radiator regularly to prevent overheating of the engine due to inadequate cooling. For example, use a garden hose with low water pressure.



ATTENTION

Bending of radiator fins

Damage to radiator fins

- Take care not to bend the radiator fins when cleaning.

Rubber

Treat rubber components with water or BMW rubber-care products.



ATTENTION

Application of silicone sprays to rubber seals

Damage to the rubber seals

- Do not use silicone sprays or care products that contain silicon.

CARE OF PAINTWORK

The long-term effects of materials that are damaging to paint can be prevented by regular vehicle washes, particularly if your vehicle is ridden in areas susceptible to high levels of air pollution or natural contamination, for example tree resin or pollen. Particularly aggressive materials, however, should be removed immediately, otherwise changes to or discolouration of the paint can result. These

include, for example, spilled fuel, oil, grease, brake fluid or bird excrement. For this, we recommend BMW Motorrad solvent cleaner followed by BMW Motorrad gloss polish for preservation.

Contamination of the paint surface can be seen particularly clearly after a vehicle wash. These areas should be cleaned immediately using benzine or spirit, applied with a clean cloth or cotton pad. BMW Motorrad recommends that tar spots be removed using BMW tar remover. The paint should then be preserved in these areas.

VEHICLE PRESERVATION

If water no longer rolls off the paint, the paint must be preserved.

For paint preservation, BMW Motorrad recommends the use of BMW Motorrad gloss polish or agents containing carnauba wax or synthetic wax.

LAYING UP MOTORCYCLE

- Fill the motorcycle's fuel tank.



Fuel additives clean the fuel injection system and the combustion zone. It is advisable to use fuel additives

when the engine is operated with low-grade fuel or if the vehicle is to be out of use for a lengthy period of time. More information is available from your authorised BMW Motorrad retailer.

- Clean the motorcycle.
- Removing battery (➡ 203).
- Spray the brake and clutch lever pivots and the side-stand and centre-stand pivot mounts with a suitable lubricant.
- Coat bright metal and chrome-plated parts with an acid-free grease (e.g. Vaseline).
- Stand the motorcycle in a dry room in such a way that there is no load on either wheel.

RESTORING MOTORCYCLE TO USE

- Remove the protective wax coating.
- Clean the motorcycle.
- Install the battery (➡ 204).
- Note the checklist (➡ 147).

TECHNICAL DATA

13

TROUBLESHOOTING CHART	220
TREADED FASTENERS	223
FUEL	225
ENGINE OIL	226
ENGINE	226
CLUTCH	227
TRANSMISSION	227
FINAL DRIVE	228
FRAME	228
CHASSIS AND SUSPENSION	228
BRAKES	229
WHEELS AND TYRES	229
ELECTRICAL SYSTEM	230
ANTI-THEFT ALARM	231
DIMENSIONS	232
WEIGHTS	232
PERFORMANCE FIGURES	232

220 TECHNICAL DATA

TROUBLESHOOTING CHART

The engine does not start.

Possible cause	Rectification
Side stand is extended	Retract the side stand.
Gear engaged and clutch not disengaged	Select neutral or pull the clutch lever.
No fuel in tank	Refuel (▮▮▮▮ 156).
Battery flat	Recharge the battery.
Overheating protection for starter motor has been activated. Starter motor can only be operated for a limited period of time.	Allow the starter motor to cool down for approx. 1 minute before using it again.

The Bluetooth connection is not established.

Possible cause	Rectification
The steps required for pairing were not carried out.	Check the necessary steps for pairing in the operating instructions for the communication system.
The communication system was not connected automatically despite successful pairing.	Switch off the helmet's communication system and reconnect it after a minute or two.
Too many Bluetooth devices are saved on the helmet.	All pairing entries on the helmet are deleted (see the communication system operating instructions).
There are other vehicles with Bluetooth-capable devices in the vicinity.	Avoid simultaneously pairing with more vehicles.

Bluetooth connection is interrupted.

Possible cause	Rectification
The Bluetooth connection to the mobile device is interrupted.	Switch off energy saving mode.
The Bluetooth connection to the helmet is interrupted.	Switch off the helmet's communication system and reconnect it after a minute or two.
Bluetooth connection interrupted.	The temperature of the TFT display is too high. Bluetooth is deactivated. The brightness of the TFT display is reduced. Keep direct sunlight off the TFT display. Interrupt your journey until the components have cooled down.
The volume in the helmet cannot be adjusted.	Switch off the helmet's communication system and reconnect it after a minute or two.
In-helmet volume is too low.	Set the mobile device's volume for media and calls to maximum.

TFT display faulty.

Possible cause	Rectification
TFT display brightness reduced.	The temperature of the TFT display is too high. The brightness of the TFT display is reduced. Keep direct sunlight off the TFT display. Interrupt your journey until the components have cooled down.

222 TECHNICAL DATA

The phonebook is not displayed in the TFT display.

Possible cause	Rectification
The phonebook was not transmitted to the vehicle.	Confirm transmission of the phone data (☰➔ 123) when pairing the mobile device.
Not all contacts are shown.	The number of phonebook entries that can be saved in the TFT display is limited. Reduce the number of phonebook entries on the mobile device.

Active route guidance is not displayed in the TFT display.

Possible cause	Rectification
Navigation from the BMW Motorrad Connected app was not transmitted.	Call up the BMW Motorrad Connected app on the paired mobile device prior to departure.
The route guidance cannot be started.	Make sure that the mobile device has a data connection and check the map data on the mobile device.

Playlist not shown on the TFT display.

Possible cause	Rectification
Too many tracks in the playlist on the mobile device.	Reduce the number of tracks in the playlist on the mobile device.





THREADED FASTENERS

Front wheel	Value	Valid
Front brake caliper to wheel carrier		
M8 x 30 - 10.9	28 Nm	
Clamping screw for quick-release axle to wheel carrier		
M8 x 30	19 Nm	
Quick-release axle in threaded bush (wheel carrier)		
M24 x 1.5	50 Nm	
Wheel-speed sensor to front suspension/rear brake caliper		
M5 x 10 - 10.9, Replace screw micro-encapsulated	4.6 Nm	
Front-wheel cover to wheel carrier		
M6 x 16, Replace screw micro-encapsulated	2 Nm	
Rear wheel	Value	Valid
Rear wheel to wheel flange		
M10 x 1.25 x 40	Tightening sequence: tighten in diagonally opposite sequence	
	60 Nm	

224 TECHNICAL DATA

Battery	Value	Valid
Battery bracket on rear carrier		
M6 x 14.5	8 Nm	

FUEL

Recommended fuel grade	 Premium unleaded (maximum 15 % ethanol,  E15) 95 ROZ/RON 90 AKI
Alternative fuel grade	 Regular unleaded (power- and consumption-related restrictions) (max 15 %  ethanol, E10/E15) 91 ROZ/RON 87 AKI
Usable fuel capacity	approx. 26.5 l
Reserve fuel	approx. 4 l
Fuel consumption	approx. 5.9 l/100 km, in accordance with WMTC
–with power reduction ^{OE}	approx. 6.2 l/100 km, in accordance with WMTC
CO ₂ emission	137 g/km, in accordance with WMTC
–with power reduction ^{OE}	143 g/km, in accordance with WMTC
Exhaust emissions standard	EU5
–with Canada export ^{NV}	TIER 2, measured in accordance with FTP75

226 TECHNICAL DATA

ENGINE OIL

Engine oil, capacity	approx. 4.5 l, with filter change
Specification	SAE 5W-40, API SJ / JASO MA2, Additives (e.g. molybdenum-based) are not permissible because they can attack coated components of the engine, BMW Motorrad recommends BMW Motorrad ADVANTEC Ultimate oil.
Engine oil, quantity for topping up	max 0.5 l, Difference between MIN and MAX

BMW recommends  **ADVANTEC**
ORIGINAL BMW ENGINE OIL

ENGINE

Engine number location	Above oil filler neck
Engine type	A40A16A
Engine design	6-cylinder, four-stroke in-line engine arranged across the direction of travel, featuring four valves per cylinder, two overhead camshafts; liquid cooling, electronic fuel injection, integrated six-speed cassette gearbox, dry-sump lubrication.
Displacement	1649 cm ³
Cylinder bore	72.0 mm
Piston stroke	67.5 mm
Compression ratio	12.2:1

Nominal capacity	118 kW, at engine speed: 6750 min ⁻¹
-with power reduction ^{OE}	79 kW, at engine speed: 5750 min ⁻¹
Torque	180 Nm, at engine speed: 5250 min ⁻¹
-with power reduction ^{OE}	160 Nm, at engine speed: 4250 min ⁻¹
Maximum engine speed	max 8500 min ⁻¹
Idle speed	900 ^{±50} min ⁻¹ , Engine at regular operating temperature

CLUTCH

Clutch type	Multi-disc oil bath
-------------	---------------------

TRANSMISSION

Type of transmission	Claw-shift 6-speed gearbox with helical gearing
Gearbox transmission ratios	1.617 (97:60 teeth), Primary transmission ratio 1.258 (39:31 teeth), Transmission input ratio 1.941 (33:17 teeth), 1. Gear 1.429 (30:21 teeth), 2. Gear 1.148 (31:27 teeth), 3. Gear 0.960 (24:25 teeth), 4. Gear 0.806 (25:31 teeth), 5. Gear 0.686 (24:35 teeth), 6. Gear 0.913 (21:23 teeth), Transmission output ratio

228 TECHNICAL DATA

FINAL DRIVE

Type of final drive	Shaft drive with bevel gears
Gear ratio of final drive	2.75 (33/12 teeth)
Type of rear suspension	Cast-aluminium single swinging arm with BMW Motorrad Paralever

FRAME

Frame type	Aluminium composite bridge frame, engine also load bearing
Type plate location	Top right wheel carrier
Position of the vehicle identification number	Rear part of the main frame above the swinging arm, pointing in the direction of travel

CHASSIS AND SUSPENSION

Front wheel

Type of front suspension	BMW Motorrad Duolever
Design of front wheel suspension	Central shock absorber with helical spring
Spring travel, front	115 mm, at wheel

Rear wheel

Type of rear-wheel suspension	Central spring strut with coil spring, adjustable rebound stage damping and spring preload
Spring travel, rear	125 mm, At wheel

BRAKES

Front wheel

Type of front brake	Twin disc brake, diameter 320 mm, 4-piston fixed caliper
Brake-pad material, front	Sintered metal
Brake disc thickness, front	5.0 mm, When new min 4.5 mm, Wear limit
Play of brake controls (Front brake)	2.3...2.7 mm, at the piston

Rear wheel

Type of rear brake	Single-disc brake, diameter 276 mm, 2-piston floating caliper
Brake-pad material, rear	Organic material
Brake disc thickness, rear	5.5 mm, When new min 4.9 mm, Wear limit
Blow-by clearance of the foot-brake lever	min 1 mm, between piston and pushrod

WHEELS AND TYRES

Recommended tyre combinations	An overview of currently approved tyres is available from your authorised BMW Motorrad retailer or on the Internet at bmw-motorrad.com .
Speed category, front/rear tyres	W, required at least: 270 km/h
Front wheel	
Front-wheel type	Aluminium cast wheel
–with Option 719 forged wheels Classic	Forged aluminium wheels
Front-wheel rim size	3.50" x 17"

230 TECHNICAL DATA

Tyre designation, front	120/70 ZR 17
Load index, front tyre	min. 58
Wheel load, front, at unladen weight	164 kg
Permissible wheel load, front	max 212 kg
Permissible front-wheel imbalance	max 5 g

Rear wheel

Rear-wheel type	Aluminium cast wheel
-with Option 719 forged wheels Classic	Forged aluminium wheels
Rear wheel rim size	6.00" x 17"
Tyre designation, rear	190/55 ZR 17
Load index, rear tyre	min. 75
Wheel load, rear, at unladen weight	172 kg
Permissible wheel load, rear	max 368 kg
Permissible rear-wheel imbalance	max 5 g

Tyre pressure

Tyre pressure, front	2.9 bar, tyre cold
Tyre pressure, rear	2.9 bar, tyre cold

ELECTRICAL SYSTEM

Electrical rating of on-board sockets	max 10 A, All sockets in total
---------------------------------------	--------------------------------

Battery

Battery type	AGM, maintenance-free
Battery rated voltage	12 V
Battery rated capacity	16 Ah

Spark plugs

Spark plugs, manufacturer and designation	NGK LMAR8AI-10
---	----------------

Light source

Bulb for high-beam headlight	LED
Bulbs for the low-beam headlight	LED
Bulb for parking light	LED
Bulb for tail light/brake light	LED
Bulbs for turn indicators	LED
Bulbs for flashing turn indicators, rear	LED
Light source for the number plate light	integrated in rear light

Fuses

Main fuse	40 A, Regulator, isolating relay, BCL
Fuse 1	7.5 A, Topcase, RDC, sensor box
Fuse 2	10 A, Instrument cluster, ignition switch, DWA, isolating relay, OBD connector
Fuse 3	15 A, Audio system

ANTI-THEFT ALARM**Anti-theft alarm**

Activation time on arming	approx. 30 s
Alarm duration	approx. 26 s
Activation time between two alarms	approx. 15 s
Battery type	CR 123 A

232 TECHNICAL DATA

DIMENSIONS

Length of motorcycle	2470 mm, over cases
Height of motorcycle	1340...1440 mm, over wind-screen, at DIN vehicle kerb weight
Width of motorcycle	1000 mm, with mirrors
Height of rider's seat	750 mm, without rider, at DIN vehicle kerb weight
Rider's inside-leg arc, heel to heel	1760 mm, without rider, at DIN vehicle kerb weight

WEIGHTS

Vehicle kerb weight	344 kg, DIN vehicle kerb weight, ready for road, 90 % load of fuel, without optional extras (OE)
Permissible gross vehicle weight	560 kg
Maximum payload	216 kg
Payload per case	max 10 kg
Payload of topcase	max 10 kg

PERFORMANCE FIGURES

Top speed	200 km/h
Maximum speed for riding with a loaded case	max 180 km/h
Top speed	
–with footboard ^{OE}	max 180 km/h, Maximum speed for journeys with footboard

SERVICE

14

REPORTING SAFETY-RELEVANT DEFECTS	236
BMW MOTORRAD SERVICE	237
BMW MOTORRAD SERVICE HISTORY	237
BMW MOTORRAD MOBILITY SERVICES	238
MAINTENANCE WORK	238
MAINTENANCE SCHEDULE	240
MAINTENANCE CONFIRMATIONS	241
SERVICE CONFIRMATIONS	253

REPORTING SAFETY-RELEVANT DEFECTS

—with Canada export^{NV}

If you think that your motorcycle has a fault which may cause an accident, injury or death, you must inform the NHTSA (National Highway Traffic Safety Administration) immediately and BMW of North America, LLC.

If the NHTSA receives other similar complaints, it may open an investigation. If it finds that a safety defect exists in a group of vehicles, the NHTSA may order the manufacturer to perform a recall and remedy campaign. However, the NHTSA cannot become involved in individual problems between you, your retailer, or BMW of North America, LLC.

You can contact the NHTSA by calling the Vehicle Safety hotline on 1-888-327-4236 (teletypewriter TTY for the hearing impaired: 1-800-424-9153) for free, by visiting the website at [http:// www.safercar.gov](http://www.safercar.gov) or by writing to Administrator, NHTSA, 400 Seventh Street, SW., Washington, DC 20590. Further information on vehicle safety is available at [http:// www.safercar.gov](http://www.safercar.gov).

Canadian customers who wish to report a safety-related defect to Transport Canada, Defect Investigations and Recalls can call the toll-free hotline 1-800-333-0510. You can also obtain other information about motor vehicle safety from [http:// www.tc.gc.ca/roadsafety](http://www.tc.gc.ca/roadsafety).

BMW MOTORRAD SERVICE

BMW Motorrad has an extensive network of retailers in place to look after you and your motorcycle in more than 100 countries. Authorised BMW Motorrad retailers have the technical information and the technical know-how to carry out reliably all preventive maintenance and repair work on your BMW.

You can locate the nearest authorised BMW Motorrad retailer by visiting our website: bmw-motorrad.com.



WARNING

Maintenance and repair work not in compliance with correct procedure

Risk of accident due to consequential damage

- BMW Motorrad recommends having work of this nature carried out on the vehicle by a specialist workshop, preferably an authorised BMW Motorrad dealer.

In order to help ensure that your BMW is always in optimum condition, BMW Motorrad recommends compliance with the maintenance intervals specified for your motorcycle.

Have all maintenance and repair work carried out confirmed in the "Service" chapter in this manual. Evidence of regular preventive maintenance is essential for generous treatment of claims submitted after the warranty period has expired.

Your authorised BMW Motorrad retailer can provide information on BMW Motorrad services and the work undertaken as part of each service.

BMW MOTORRAD SERVICE HISTORY

Entries

Maintenance work that has been carried out is entered in the proof of maintenance. The entries are like a Service Booklet and provide proof of regular maintenance.

When an entry is made in the electronic service booklet of the vehicle, service-relevant data is saved in the central IT

238 SERVICE

systems of BMW AG, Munich, Germany.

If there is a change in vehicle ownership, the data saved in the electronic service booklet can also be viewed by the new vehicle owner. A BMW Motorrad retailer or a specialist workshop can also view data that is stored in the electronic service booklet.

Objection

The vehicle owner can object to entries being made by the BMW Motorrad retailer or a specialist workshop in the electronic service booklet along with the corresponding storage of data in the vehicle and transfer of data to the vehicle manufacturer for the period of time that they are the vehicle owner. In this instance, no entry is made in the electronic service booklet of the vehicle.

BMW MOTORRAD MOBILITY SERVICES

As owner of a new BMW motorcycle, in circumstances in which assistance is required you can benefit from the protection afforded by the various BMW Motorrad mobility services (e.g. Mobile Service,

breakdown service, vehicle recovery service).

Your authorised BMW Motorrad dealer will be happy provide information about the mobility services available to you.

MAINTENANCE WORK

BMW Pre-delivery Check

Your authorised BMW Motorrad dealer conducts the BMW pre-delivery check before handing over the vehicle to you.

BMW Running-in Check

The BMW running-in check has to be performed when the motorcycle has covered between 500 km and 1200 km

BMW Motorrad Service

The BMW Motorrad Service is carried out once a year; the extent of servicing can vary, depending on the age of the vehicle and the distance it has covered. Your authorised BMW Motorrad retailer confirms that the service work has been carried out and enters the date when the next service will be due.

Riders who cover long distances in a year might have to bring in their vehicles for service before the next scheduled date. It is to allow for

these cases that a maximum odometer reading is entered as well in the confirmation of service. Servicing has to be brought forward if this odometer reading is reached before the next scheduled date for the service.

The service display in the multifunction display reminds you about one month or 1000 km in advance when the time for a service is approaching, on the basis of the programmed values.

To find out more about service go to:

bmw-motorrad.com/service

The maintenance tasks necessary for your vehicle are set out in the maintenance schedule below.

240 SERVICE

MAINTENANCE SCHEDULE

	500 -1200 km 300 - 750 mls	10 000 km 6 000 mls	20 000 km 12 000 mls	30 000 km 18 000 mls	40 000 km 24 000 mls	50 000 km 30 000 mls	60 000 km 36 000 mls	70 000 km 42 000 mls	80 000 km 48 000 mls	90 000 km 54 000 mls	100 000 km 60 000 mls	12 months	24 months
1	X												
2												X	
3		X	X	X	X	X	X	X	X	X	X	X ^a	
4			X		X		X		X		X		
5				X			X			X			
6				X			X			X			
7													X
8			X		X		X		X		X		X ^b
9												X ^a	X ^c

- 1 BMW Motorrad running-in check (including oil change and oil filter change)
- 2 BMW Motorrad Service, standard scope
- 3 Engine-oil change, with filter
- 4 Replace air-filter element
- 5 Check valve clearances
- 6 Replace all spark plugs
- 7 Check the bearing for deflection on the rear wheel swinging arm
- 8 Oil change in bevel gears rear

- 9 Change brake fluid, entire system
 - a annually or every 10,000 km (whichever comes first)
 - b every 2 years or every 20,000 km (whichever comes first)
 - c for the first time after one year, then every two years

MAINTENANCE CONFIRMATIONS

BMW Motorrad Service standard scope

The tasks included in the BMW_Motorrad Service standard scope are listed below. The actual scope of maintenance work applicable for your vehicle may vary.

- Performing vehicle test with BMW Motorrad diagnosis system
- Draining the condensate hose
- Visual inspection of the brake lines, brake hoses and connections
- Checking front brake pads and brake discs for wear
- Checking brake-fluid level, front wheel brake
- Checking rear brake pads and brake disc for wear
- Checking brake-fluid level, rear wheel brake
- Visual inspection of clutch system
- Checking coolant level
- Checking tyre pressure and tread depth
- Check the side stand's ease of movement
- Checking ease of movement of the centre stand
- Check lighting and signalling system
- Function test, engine start suppression
- Final inspection and check for road safety
- Setting service-due date and countdown distance with BMW Motorrad diagnosis system
- Checking battery state of charge
- Confirming BMW Motorrad service in on-board literature

242 SERVICE

BMW pre-delivery check
carried out

on _____

Stamp, signature

BMW Running-in Check
carried out

on _____

odometer reading _____

Next service

at the latest

on _____

or, when reached earlier

odometer reading _____

Stamp, signature

BMW Motorrad service

carried out

on _____

odometer reading _____

Next service

at the latest

on _____

or, when reached earlier

odometer reading _____

Work performed

	Yes	No
BMW Motorrad service	<input type="checkbox"/>	<input type="checkbox"/>
Oil change, engine, with filter	<input type="checkbox"/>	<input type="checkbox"/>
Renewing air cleaner insert	<input type="checkbox"/>	<input type="checkbox"/>
Checking valve clearance	<input type="checkbox"/>	<input type="checkbox"/>
Renewing all spark plugs	<input type="checkbox"/>	<input type="checkbox"/>
Check bearing for deflection at rear wheel swinging arm (in maintenance	<input type="checkbox"/>	<input type="checkbox"/>
Oil change in rear bevel gears	<input type="checkbox"/>	<input type="checkbox"/>
Change brake fluid in entire system	<input type="checkbox"/>	<input type="checkbox"/>

Notes

Stamp, signature

244 SERVICE

BMW Motorrad service

carried out

on _____

odometer reading _____

Next service

at the latest

on _____

or, when reached earlier

odometer reading _____

Work performed

	Yes	No
BMW Motorrad service	<input type="checkbox"/>	<input type="checkbox"/>
Oil change, engine, with filter	<input type="checkbox"/>	<input type="checkbox"/>
Renewing air cleaner insert	<input type="checkbox"/>	<input type="checkbox"/>
Checking valve clearance	<input type="checkbox"/>	<input type="checkbox"/>
Renewing all spark plugs	<input type="checkbox"/>	<input type="checkbox"/>
Check bearing for deflection at rear wheel swinging arm (in maintenance	<input type="checkbox"/>	<input type="checkbox"/>
Oil change in rear bevel gears	<input type="checkbox"/>	<input type="checkbox"/>
Change brake fluid in entire system	<input type="checkbox"/>	<input type="checkbox"/>

Notes

Stamp, signature

BMW Motorrad service

carried out

on _____

odometer reading _____

Next service

at the latest

on _____

or, when reached earlier

odometer reading _____

Work performed

	Yes	No
BMW Motorrad service	<input type="checkbox"/>	<input type="checkbox"/>
Oil change, engine, with filter	<input type="checkbox"/>	<input type="checkbox"/>
Renewing air cleaner insert	<input type="checkbox"/>	<input type="checkbox"/>
Checking valve clearance	<input type="checkbox"/>	<input type="checkbox"/>
Renewing all spark plugs	<input type="checkbox"/>	<input type="checkbox"/>
Check bearing for deflection at rear wheel swinging arm (in maintenance	<input type="checkbox"/>	<input type="checkbox"/>
Oil change in rear bevel gears	<input type="checkbox"/>	<input type="checkbox"/>
Change brake fluid in entire system	<input type="checkbox"/>	<input type="checkbox"/>

Notes

Stamp, signature

246 SERVICE

BMW Motorrad service

carried out

on_____

odometer reading_____

Next service

at the latest

on_____

or, when reached earlier

odometer reading_____

Work performed

	Yes	No
BMW Motorrad service	<input type="checkbox"/>	<input type="checkbox"/>
Oil change, engine, with filter	<input type="checkbox"/>	<input type="checkbox"/>
Renewing air cleaner insert	<input type="checkbox"/>	<input type="checkbox"/>
Checking valve clearance	<input type="checkbox"/>	<input type="checkbox"/>
Renewing all spark plugs	<input type="checkbox"/>	<input type="checkbox"/>
Check bearing for deflection at rear wheel swinging arm (in maintenance	<input type="checkbox"/>	<input type="checkbox"/>
Oil change in rear bevel gears	<input type="checkbox"/>	<input type="checkbox"/>
Change brake fluid in entire system	<input type="checkbox"/>	<input type="checkbox"/>

Notes

Stamp, signature

BMW Motorrad service

carried out

on _____

odometer reading _____

Next service

at the latest

on _____

or, when reached earlier

odometer reading _____

Work performed

	Yes	No
BMW Motorrad service	<input type="checkbox"/>	<input type="checkbox"/>
Oil change, engine, with filter	<input type="checkbox"/>	<input type="checkbox"/>
Renewing air cleaner insert	<input type="checkbox"/>	<input type="checkbox"/>
Checking valve clearance	<input type="checkbox"/>	<input type="checkbox"/>
Renewing all spark plugs	<input type="checkbox"/>	<input type="checkbox"/>
Check bearing for deflection at rear wheel	<input type="checkbox"/>	<input type="checkbox"/>
swinging arm (in maintenance		
Oil change in rear bevel gears	<input type="checkbox"/>	<input type="checkbox"/>
Change brake fluid in entire system	<input type="checkbox"/>	<input type="checkbox"/>

Notes

Stamp, signature

248 SERVICE

BMW Motorrad service

carried out

on _____

odometer reading _____

Next service

at the latest

on _____

or, when reached earlier

odometer reading _____

Work performed

	Yes	No
BMW Motorrad service	<input type="checkbox"/>	<input type="checkbox"/>
Oil change, engine, with filter	<input type="checkbox"/>	<input type="checkbox"/>
Renewing air cleaner insert	<input type="checkbox"/>	<input type="checkbox"/>
Checking valve clearance	<input type="checkbox"/>	<input type="checkbox"/>
Renewing all spark plugs	<input type="checkbox"/>	<input type="checkbox"/>
Check bearing for deflection at rear wheel swinging arm (in maintenance	<input type="checkbox"/>	<input type="checkbox"/>
Oil change in rear bevel gears	<input type="checkbox"/>	<input type="checkbox"/>
Change brake fluid in entire system	<input type="checkbox"/>	<input type="checkbox"/>

Notes

Stamp, signature

BMW Motorrad service

carried out

on _____

odometer reading _____

Next service

at the latest

on _____

or, when reached earlier

odometer reading _____

Work performed

	Yes	No
BMW Motorrad service	<input type="checkbox"/>	<input type="checkbox"/>
Oil change, engine, with filter	<input type="checkbox"/>	<input type="checkbox"/>
Renewing air cleaner insert	<input type="checkbox"/>	<input type="checkbox"/>
Checking valve clearance	<input type="checkbox"/>	<input type="checkbox"/>
Renewing all spark plugs	<input type="checkbox"/>	<input type="checkbox"/>
Check bearing for deflection at rear wheel swinging arm (in maintenance	<input type="checkbox"/>	<input type="checkbox"/>
Oil change in rear bevel gears	<input type="checkbox"/>	<input type="checkbox"/>
Change brake fluid in entire system	<input type="checkbox"/>	<input type="checkbox"/>

Notes

Stamp, signature

250 SERVICE

BMW Motorrad service

carried out

on _____

odometer reading _____

Next service

at the latest

on _____

or, when reached earlier

odometer reading _____

Work performed

	Yes	No
BMW Motorrad service	<input type="checkbox"/>	<input type="checkbox"/>
Oil change, engine, with filter	<input type="checkbox"/>	<input type="checkbox"/>
Renewing air cleaner insert	<input type="checkbox"/>	<input type="checkbox"/>
Checking valve clearance	<input type="checkbox"/>	<input type="checkbox"/>
Renewing all spark plugs	<input type="checkbox"/>	<input type="checkbox"/>
Check bearing for deflection at rear wheel swinging arm (in maintenance	<input type="checkbox"/>	<input type="checkbox"/>
Oil change in rear bevel gears	<input type="checkbox"/>	<input type="checkbox"/>
Change brake fluid in entire system	<input type="checkbox"/>	<input type="checkbox"/>

Notes

Stamp, signature

BMW Motorrad service

carried out

on _____

odometer reading _____

Next service

at the latest

on _____

or, when reached earlier

odometer reading _____

Work performed

	Yes	No
BMW Motorrad service	<input type="checkbox"/>	<input type="checkbox"/>
Oil change, engine, with filter	<input type="checkbox"/>	<input type="checkbox"/>
Renewing air cleaner insert	<input type="checkbox"/>	<input type="checkbox"/>
Checking valve clearance	<input type="checkbox"/>	<input type="checkbox"/>
Renewing all spark plugs	<input type="checkbox"/>	<input type="checkbox"/>
Check bearing for deflection at rear wheel	<input type="checkbox"/>	<input type="checkbox"/>
swinging arm (in maintenance		
Oil change in rear bevel gears	<input type="checkbox"/>	<input type="checkbox"/>
Change brake fluid in entire system	<input type="checkbox"/>	<input type="checkbox"/>

Notes

Stamp, signature

252 SERVICE

BMW Motorrad service

carried out

on_____

odometer reading_____

Next service

at the latest

on_____

or, when reached earlier

odometer reading_____

Work performed

	Yes	No
BMW Motorrad service	<input type="checkbox"/>	<input type="checkbox"/>
Oil change, engine, with filter	<input type="checkbox"/>	<input type="checkbox"/>
Renewing air cleaner insert	<input type="checkbox"/>	<input type="checkbox"/>
Checking valve clearance	<input type="checkbox"/>	<input type="checkbox"/>
Renewing all spark plugs	<input type="checkbox"/>	<input type="checkbox"/>
Check bearing for deflection at rear wheel swinging arm (in maintenance	<input type="checkbox"/>	<input type="checkbox"/>
Oil change in rear bevel gears	<input type="checkbox"/>	<input type="checkbox"/>
Change brake fluid in entire system	<input type="checkbox"/>	<input type="checkbox"/>

Notes

Stamp, signature

DECLARATION OF CONFORMITY	257
CERTIFICATE FOR TFT INSTRUMENT CLUSTER	262
CERTIFICATE FOR AUDIO SYSTEM	266
CERTIFICATE FOR ELECTRONIC IMMOBILISER	267
CERTIFICATE FOR KEYLESS RIDE	270
CERTIFICATE FOR TYRE PRESSURE CONTROL (RE- IFENDRUCK-CONTROL, RDC)	274
EMERGENCY CALL	275

DECLARATION OF CONFORMITY

Simplified EU Declaration of Conformity under RED (2014/53/EU).



Vehicular immobilizer system transceiver EWS4

Technical information

Frequency band: 134 kHz
 Transponder: TMS37145 / TypeDST80, TMS3705 Transponder Base Station IC
 Output Power: 50 dB μ V/m

Manufacturer

BECOM Electronics GmbH
 Technikerstraße 1, A-7442
 Hochstraß, Austria

Hereby, BECOM Electronics GmbH declares that the vehicular immobilizer system transceiver EWS4 is in compliance with Directive 2014/53/EU. The full text of the EU declaration of conformity is available at the following internet ad-

dress:

bmw-motorrad.com/certification

Keyless Ride HUF5750

Technical information

Frequency band: 434,42 MHz
 Transmission Power: 10 mW

Manufacturer

Huf Hüsbeck & Fürst GmbH & Co. KG
 Steeger Str. 17, 42551 Velbert, Germany

Hereby, Huf Hüsbeck & Fürst GmbH & Co. KG declares that the radio equipment type HUF5750 is in compliance with Directive 2014/53/EU. The full text of the EU declaration of conformity is available at the following internet address: **bmw-motorrad.com/certification**

Keyless Ride HUF8465

Technical information

Frequency band: 134,45 kHz
 Output Power: 42 dB μ V/m

Manufacturer

Huf Hüsbeck & Fürst GmbH & Co. KG
 Steeger Str. 17, 42551 Velbert, Germany

258 APPENDIX

Hereby, Huf Hüsbeck & Fürst GmbH & Co. KG declares that the radio equipment type HUF8465 is in compliance with Directive 2014/53/EU. The full text of the EU declaration of conformity is available at the following internet address:

bmw-motorrad.com/certification

Anti-theft alarm (DWA)

TXBMWMR

Technical information

Frequency band: 433.05 MHz - 434.79 MHz

Output power: 10 mW e.r.p.

Manufacturer

Meta System S.p.A.
Via Galimberti 5, 42124 Reggio Emilia, Italy

Hereby, Meta System S.p.A. declares that the radio equipment type TXBMWMR is in compliance with Directive 2014/53/EU. The full text of the EU declaration of conformity is available at the following internet address:

bmw-motorrad.com/certification

Tyre pressure control (RDC) BC5A4

Technical information

Frequency band: 433.895 - 433.945 MHz

Output Power: <10 mW e.r.p.

Manufacturer

Schrader Electronics Ltd.
Technology Park, N. Ireland
BT41 1QS Antrim, United Kingdom

Hereby, Schrader Electronics Ltd. declares that the radio equipment type BC5A4 is in compliance with Directive 2014/53/EU. The full text of the EU declaration of conformity is available at the following internet address:

bmw-motorrad.com/certification

Wireless charging device WCA Motorrad-Ladestauaufach

Technical information

Frequency band: 110 kHz - 115 kHz

Output power: < 6 W

Manufacturer

Bury Sp. z o.o.
ul. Wojska Polskiego 4, 39-300 Mielec, Poland

Hereby, Bury Sp. z o.o. declares that the radio equipment type WCA Motorrad-Ladestafach is in compliance with Directive 2014/53/EU. The full text of the EU declaration of conformity is available at the following internet address:

bmw-motorrad.com/certification

TFT instrument cluster ICC6.5in

Technical information

BT operating frq. Range: 2402 MHz - 2480 MHz

BT version: 4.2 (no BTLE)

BT output power: < 4 dBm

WLAN operating frq. Range: 2412 MHz - 2462 MHz

WLAN standards: IEEE 802.11 b/g/n

WLAN output power: < 20 dBm

Manufacturer

Robert Bosch Car Multimedia GmbH
Robert Bosch Str. 200, 31139 Hildesheim, Germany

Hereby, Robert Bosch Car Multimedia GmbH declares that the radio equipment type ICC6.5in is in compliance with Directive 2014/53/EU. The full text of the EU declaration of conformity is available at the

following internet address:

bmw-motorrad.com/certification

TFT instrument cluster ICC10n

Technical information

The ICC10in can operate in one of two operating modes:

1. Normal mode, with Bluetooth and WLAN on, and
2. Radio off mode (only available during vehicle manufacturing).

BT operating frq. Range: 2402 MHz - 2480 MHz

BT version: 4.2 (no BTLE)

BT output power: < +4 dBm (internal antenna)

WLAN operating frq. Range: 2402 MHz - 2472 MHz

WLAN standards: IEEE 802.11 b/g/n

WLAN output power: <+14 dBm (internal antenna)

Manufacturer

Robert Bosch GmbH
Robert-Bosch-Platz 1, 70839 Gerlingen, Germany

Hereby, Robert Bosch GmbH declares that the radio equipment type ICC10in is in compliance with Directive 2014/53/EU. The full text of the EU declaration of conformity is available at the following internet address:

260 APPENDIX

bmw-motorrad.com/certification

Intelligent emergency call TPM E-CALL EU

Technical information

Antenna internal:

Frequency band: 880 MHz - 915 MHz

Radiated Power [TRP]: < 22 dBm

Not accessible by user:

Frequency band: 1710 MHz - 1785 MHz

Radiated Power [TRP]: < 26 dBm

Frequency band: 1920 MHz - 1980 MHz

Radiated Power [TRP]: < 22 dBm

Frequency band: 880 MHz - 915 MHz

Radiated Power [TRP]: < 23 dBm

Manufacturer

Robert Bosch Car Multimedia GmbH

Robert Bosch Str. 200, 31139 Hildesheim, Germany

Hereby, Robert Bosch Car Multimedia GmbH declares that the radio equipment type TPM E-CALL EU is in compliance with Directive 2014/53/EU. The full text of the EU declaration of conformity is available at the following internet ad-

dress:

bmw-motorrad.com/certification

Mid Range Radar MRRe14FCR

Technical information

Frequency band: 76 - 77 GHz
Nominal radiated power: e.i.r.p. (peak detector): 32 dBm
Nominal radiated power:e.i.r.p. (RMS detector): 27 dBm

Manufacturer

Robert Bosch GmbH
Robert-Bosch-Platz 1, 70839 Gerlingen, Germany

Hereby, Robert Bosch GmbH declares that the radio equipment type MRRe14FCR is in compliance with Directive 2014/53/EU. The full text of the EU declaration of conformity is available at the following internet address:

bmw-motorrad.com/certification

Audio system MCR001 Manufacturer

ALPS ALPINE CO., LTD.

Hereby, ALPS ALPINE CO., LTD. declares that the radio equipment type MCR001 is in compliance with Directive 2014/53/EU. The full text of the EU declaration of conformity is available at the following in-

ternet address:

**bmw-motorrad.com/certifica-
tion**

Declaration of Conformity

Radio equipment TFT instrument cluster

For all Countries without EU

Model name: ICC10in

Technical information

The ICC10in can operate in one of two operating modes:

1. Normal mode, with Bluetooth and WLAN on, and
2. Radio off mode (only available during vehicle manufacturing).

BT operating frq. Range:
2402 – 2480 MHz

BT version: 4.2 (no BTLE)

BT output power:

< +4 dBm (internal antenna)

WLAN operating frq. Range:
2402 – 2472 MHz

WLAN standards:

IEEE 802.11 b/g/n

WLAN output power:

< +14 dBm (internal antenna)

Manufacturer and Address

Manufacturer:

Robert Bosch GmbH

Address:

Robert-Bosch-Platz 1,
70839 Gerlingen, Germany

Turkey

Robert Bosch GmbH, ICC10in tipi telsiz sisteminin 2014/53/EU nolu yönetmeliğe uygun olduğunu beyan eder. AB Uygunluk Beyanı'nın tam metni, aşağıdaki internet adresinden görülebilir: <http://cert.bosch-carmultimedia.net>

Brazil

Este equipamento não tem direito de proteção contra interferência prejudicial e não pode causar interferência em sistemas devidamente autorizados. Para maiores informações, consulte o site da ANATEL www.anatel.gov.br

Thailand

เครื่องโทรคมนาคมและอุปกรณ์นี้ มีความสอดคล้องตามข้อกำหนดของ กทช.
(This telecommunication equipments is in compliance with NTC requirements)

Argentina

 **RAMATEL**

C-25636

Canada

This device contains licence-exempt transmitter(s)/ receiver(s) that comply with Innovation, Science and Economic Development Canada's licence-exempt RSS(s). Operation is subject to the following two conditions:

- (1) This device may not cause interference.
- (2) This device must accept any interference, including interference that may cause undesired operation of the device.

Radiofrequency radiation exposure Information: This equipment complies with Canada radiation exposure limits set forth for an uncontrolled environment. This equipment should be installed and operated with minimum distance of 20 centimeters between the radiator and your body. This transmitter must not be co-located or operating in conjunction with any other antenna or transmitter.

L'émetteur/récepteur exempt de licence contenu dans le présent appareil est conforme aux CNR d'Innovation, Sciences et Développement économique Canada applicables aux appareils radio exempts de licence. L'exploitation est autorisée aux deux conditions suivantes :

- (1) L'appareil ne doit pas produire de brouillage;
- (2) L'appareil doit accepter tout brouillage radioélectrique subi, même si le brouillage est susceptible d'en compromettre le fonctionnement.

Informations sur l'exposition aux radiofréquences:

Cet équipement est conforme aux limites d'exposition aux radiations fixées par le Canada pour un environnement non contrôlé. Cet équipement doit être installé et utilisé avec une distance minimale de 20 centimètres entre le radiateur et votre corps. Cet émetteur ne doit pas être co-localisée ou opérant en conjonction avec autre antenne ou émetteur.

United States (USA)

This device complies with part 15 of the FCC Rules. Operation is subject to the following two conditions:

- (1) This device may not cause harmful interference, and
- (2) this device must accept any interference received, including interference that may cause undesired operation.

Changes or modifications made to this equipment not expressly approved by Robert Bosch GmbH may void the FCC authorization to operate this equipment.

NOTE: This equipment has been tested and found to comply with the limits for a Class B digital device, pursuant to Part 15 of the FCC Rules. These limits are designed to provide reasonable protection against harmful interference in a residential installation. This equipment generates, uses and can radiate radio frequency energy and, if not installed and used in accordance with the instructions, may cause harmful interference to radio communications.

However, there is no guarantee that interference will not occur in a particular installation. If this equipment does cause harmful interference to radio or television reception, which can be determined by turning the equipment off and on, the user is encouraged to try to correct the interference by one or more of the following measures:

- Reorient or relocate the receiving antenna.
- Increase the separation between the equipment and receiver.
- Connect the equipment into an outlet on a circuit different from that to which the receiver is connected.
- Consult the dealer or an experienced radio/TV technician for help.

Radiofrequency radiation exposure Information: This equipment complies with FCC radiation exposure limits set forth for an uncontrolled environment. This equipment should be installed and operated with minimum distance of 20 cm between the radiator and your body. This transmitter must not be co-located or operating in conjunction with any other antenna or transmitter.

Japan

This device is granted pursuant to the Japanese Radio Law (電波法) and the Japanese

Telecommunications Business Law (電気通信事業法)

本製品は、電波法と電気通信事業法に基づく適合証明を受けております。

This device should not be modified (otherwise the granted designation number will become invalid)

本製品の改造は禁止されています。(適合証明番号などが無効となります。)



R

201-200559

T

20 0138 201

Korea

Equipment Name: BMW A-Kombi

Basic model number: ICC10in

Manufacturer/Country of Origin:

Robert Bosch GmbH / 포르투갈

Zertifikatsnummer:

R-R-BO2-ICC10in

Serbia



ID: И011 20

Mexico

La operación de este equipo está sujeta a las siguientes dos condiciones:

- (1) es posible que este equipo o dispositivo no cause interferencia perjudicial y
- (2) este equipo o dispositivo debe aceptar cualquier interferencia, incluyendo la que pueda causar su operación no deseada.



Taiwan, Republic of

取得審驗證明之低功率射頻器材，非經核准，公司、商號或使用者均不得擅自變更頻率、加大功率或變更原設計之特性及功能。低功率射頻器材之使用不得影響飛航安全及干擾合法通信；經發現有干擾現象時，應立即停用，並改善至無干擾時方得繼續使用。前述合法通信，指依電信管理法規定作業之無線電通信。低功率射頻器材須忍受合法通信或工業、科學及醫療用電波輻射性電機設備之干擾。

Declaration of Conformity

Radio equipment audio system

Model name: MCR001

This device complies with part 15 of the FCC Rules. Operation is subject to the following two conditions:

- (1) This device may not cause harmful interference, and
- (2) this device must accept any interference received, including interference that may cause undesired operation.

FCC CAUTION

Changes or modifications not expressly approved by the party responsible for compliance could void the user's authority to operate the equipment.

Cet appareil est conforme à la partie 15 des règles FCC. Son fonctionnement est soumis aux deux conditions suivantes :

- (1) Cet appareil ne doit pas causer d'interférences nuisibles, et
- (2) cet appareil doit accepter toute interférence reçue, y compris les interférences pouvant entraîner un fonctionnement indésirable.

ATTENTION FCC

Les changements ou modifications non expressément approuvés par la partie responsable de la conformité peuvent annuler le droit de l'utilisateur à faire fonctionner l'équipement.

Declaration of Conformity

Radio equipment electronic immobiliser (EWS4)

For all countries without EU

Technical information

Frequency Band: 134 kHz
(Transponder: TMS37145 /
Type DST80, TMS3705
Transponder Base Station IC)
Output Power: 50 dB μ V/m

Manufacturer and Address

Manufacturer:
BECOM Electronics GmbH
Address: Technikerstraße 1,
A-7442 Hochstraß

Argentina

 RAMATEL

H-25246

Australia/New Zealand



R-NZ

Brunei



TA No: DTA-007061

United Arab Emirates

TRA
REGISTERED No:
ER89926/20

DEALER No:
DA96133I20

Philippiens



NTC

Type Approved
No.: ESD-RCE-2023298

South Africa



TA-2020/6131

APPROVED

India

ETA-SD-20200905860

Belarus



Indonesia

72790/SDPPI/2021
13349



Dilarang melakukan perubahan
Spesifikasi yang dapat
Menimbulkan gangguan fisik
dan/atau elektromagnetik
terhadap lingkungan sekitarnya

Paraguay

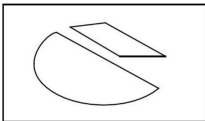

CONATEL

NR: 2020-11-I-0834

Singapore

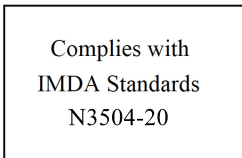

Taiwan



低功 電波 射性電機管 辦法
第十二條 經型式認證合格之低
功率射頻電機，非經許可，公
司、商號或使用者均不得擅 自變
更頻率、加大功率或變更原設計
之特性及 功能。第十四條 低功
率射頻電機之使用不 得影響飛航
安全及干擾合法通信；經發現有
干 擾現象時，應立即停用，並改
善至無干擾時方 得繼續使用。前
項合法通信，指依電信法規定作
業之無線電 通信。

Malaysia



RFCL/47A/0920/S(20-3358)

Israel

מספר אישור אלחוטני של משרד התקשורת הוא
51-74908
אסור להחליף את האנטנה המקורית של המכשיר
ולא
לעשות בו כל שינוי טכני אחר

United States (USA)

Contains FCC ID:

ODE-MREWS5012

FCC § 15.19 Labelling requirements

This device complies with part 15 of the FCC Rules and Industry Canada's licence-exempt RSS standard(s). Operation is subject to the following two conditions:

- (1) this device may not cause interference, and
- (2) this device must accept any interference received, including interference that may cause undesired operation.

FCC § 15.21 Information to user

Changes or modifications not expressly approved by the party responsible for compliance could void the user's authority to operate the equipment.

RF Exposure Requirements

To comply with FCC RF exposure compliance requirements, the device must be installed to provide a separation distance of at least 20 cm from all persons.

Serbia



P1620118300

Canada

Contains IC:

10430A-MREWS5012

This device complies with part 15 of the FCC Rules and Industry Canada license-exempt RSS standard(s). Operation is subject to the following two conditions:

- (1) this device may not cause interference, and
- (2) this device must accept any interference received, including interference that may cause undesired operation.

Le présent appareil est conforme aux CNR d'Industrie Canada applicables aux appareils radio exempts de licence. L'exploitation est autorisée aux deux conditions suivantes : (1) l'appareil ne doit pas produire de brouillage, et (2) l'utilisateur de l'appareil doit accepter tout brouillage radioélectrique subi, même si le brouillage est susceptible d'en compromettre le fonctionnement.

Vietnam

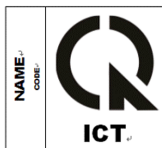

A1109091120AF04A3

Certifications

BMW Keyless Ride ID Device



USA, Canada:

Product name: BMW Keyless Ride ID
Device FCC ID: YGOHUF5750
IC: 4008C-HUF5750



Any changes or modifications not expressly approved by the party responsible for compliance could void the user's authority to operate the equipment.

Canada:

Operation is subject to the following two conditions:

- (1) This device may not cause harmful interference, and
- (2) this device must accept any interference received, including interference that may cause undesired operation.

USA:

This device complies with Part 15 of the FCC rules. Operation is subject to the following two conditions:

- (1) This device may not cause harmful interference, and
- (2) this device must accept any interference received, including interference that may cause undesired operation.

Argentina:

CNC COMISIÓN NACIONAL
DE COMUNICACIONES

H-17115

Declaration Of Conformity

We declare under our responsibility that the product

BMW Keyless Ride ID Device (Model: HUF5750)

complies with the appropriate essential requirements of the article 3 of the R&TIE and the other relevant provisions, when used for its intended purpose. Applied Standards:

1. Health and safety requirements contained in article 3 (1) a)
 - EN 60950-1:2006+A11:2009+A1:2010+A12:2011; Information technology equipment-Safety
2. Protection requirements with respect to electromagnetic compatibility article 3 (1) b)
 - EN 301 489-1 (V1 .9.2, 09/2011), Electromagnetic compatibility and radio spectrum matters (ERM); Electromagnetic compatibility (EMC) standard for radio equipment and services; Part 1: Common technical requirements
 - EN 301 489-3 (V1.4.1, 08/2002) Electromagnetic compatibility and radio spectrum matters (ERM); Electromagnetic compatibility (EMC) standard for radio equipment and services; Part 3: Specific conditions for short range devices (SRD) operating on frequencies between 9 kHz and 40 GHz
3. Means of the efficient use of the radio frequency spectrum article 3 (2)
 - EN 300 220-1 & -2 (V2.4.1, 05/2012), electromagnetic compatibility and radio spectrum matters (ERM); Short range devices (SRD); Radio equipment to be used in the 25 MHz to 1000 MHz frequency range with power levels ranging up to 500 mW; Part 1: Technical characteristics and test methods. Part 2: Harmonized EN covering essential requirements under article 3.2 of the R&TIE directive

The product is labeled with the CE marking:

CE

Velbert, October 15th, 2013

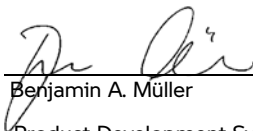

Benjamin A. Müller

Product Development Systems
Car Access and Immobilization -
Electronics Huf Hülsbeck & Fürst
GmbH & Co. KG
Steeger Straße 17, D-42551
Velbert

Certification Tire Pressure Control (TPC)

FCC ID: MRXBC54MA4
IC: 2546A-BC54MA4

FCC ID: MRXBC5A4
IC: 2546A-BC5A4

This device complies with Part 15 of the FCC Rules and with Industry Canada license-exempt RSS standard(s).

Operation is subject to the following two conditions:

- (1) This device may not cause harmful interference, and
- (2) This device must accept any interference received, including interference that may cause undesired operation.

WARNING: Changes or modifications not expressly approved by the party responsible for compliance could void the user's authority to operate the equipment. The term "IC:" before the radio certification number only signifies that Industry Canada technical specifications were met.

Le présent appareil est conforme aux CNR d'Industrie Canada applicables aux appareils radio exempts de licence. L'exploitation est autorisée aux deux conditions suivantes:

- (1) l'appareil ne doit pas produire de brouillage, et
- (2) l'utilisateur de l'appareil doit accepter tout brouillage radioélectrique subi, même si le brouillage est susceptible d'en compromettre le fonctionnement.

WARNING: Changes or modifications not expressly approved by the party responsible for compliance could void the user's authority to operate the equipment. The term "IC:" before the radio certification number only signifies that Industry Canada technical specifications were met.

DECLARATION OF CONFORMITY

Simplified EU Declaration of Conformity under RED (2014/53/EU).



Radio equipment intelligent emergency call TL1P22

Technical information

Frequency Band: 880-915 MHz

Output Power: 33 dBm

Frequency Band:

1710-1785 MHz

Output Power: 30 dBm

Frequency Band:

1920-1980 MHz

Output Power: 24 dBm

Frequency Band:

2500-2570 MHz

Output Power: 23 dBm

Frequency Band: 832-862 MHz

Output Power: 23dBm

Frequency Band:

2570-2620 MHz

Output Power: 23 dBm

Frequency Band:

1559-1610 MHz

Manufacturer

LG ELECTRONICS INC.
10, Magokjungang 10-ro,
Gangseo-gu, Seoul,
Republic of Korea

German

Hiermit erklärt LG ELECTRONICS INC., dass der Funkanlagentyp TL1P22 der Richtlinie 2014/53/EU entspricht.

Der vollständige Text der EU-Konformitätserklärung ist unter der folgenden Internetadresse verfügbar: **bmw-motorrad.com/certificates**

French

Le soussigné, LG ELECTRONICS INC., déclare que l'équipement radioélectrique du type TL1P22 est conforme à la directive 2014/53/UE.

Le texte complet de la déclaration UE de conformité est disponible à l'adresse internet suivante: **bmw-motorrad.com/certificates**

Dutch

Hierbij verklaar ik, LG ELECTRONICS INC., dat het type radioapparatuur TL1P22 conform is met Richtlijn 2014/53/EU.

De volledige tekst van de EU-conformiteitsverklaring kan worden geraadpleegd op het volgende internetadres: **bmw-motorrad.com/certificates**

English

Hereby, LG ELECTRONICS INC. declares that the radio equipment type TL1P22 is in compliance with Directive 2014/53/EU. The full text of the EU declaration of conformity is available at the following internet address: **bmw-motorrad.com/certificates**

Bulgarian

С настоящото LG ELECTRONICS INC. декларира, че този тип радиосъоръжение TL1P22 е в съответствие с Директива 2014/53/ЕС. Цялостният текст на ЕС декларацията за съответствие може да се намери на следния интернет адрес: **bmw-motorrad.com/certificates**

Cypriot/Greek

Με την παρούσα ο/η LG ELECTRONICS INC., δηλώνει ότι ο ραδιοεξοπλισμός TL1P22 πληροί την οδηγία 2014/53/ΕΕ. Το πλήρες κείμενο της δήλωσης συμμόρφωσης ΕΕ διατίθεται στην ακόλουθη ιστοσελίδα στο διαδίκτυο: **bmw-motorrad.com/certificates**

Slovenian

LG ELECTRONICS INC. potrjuje, da je tip radijske opreme TL1P22 skladen z Direktivo 2014/53/EU. Celotno besedilo izjave EU o skladnosti je na voljo na naslednjem spletnem naslovu: **bmw-motorrad.com/certificates**

Czech

Tímto LG ELECTRONICS INC. prohlašuje, že typ rádiového zařízení TL1P22 je v souladu se směrnicí 2014/53/EU. Úplné znění EU prohlášení o shodě je k dispozici na této internetové adrese: **bmw-motorrad.com/certificates**

Danish

Hermed erklærer LG ELECTRONICS INC., at radioudstyrstypen TL1P22 er i overensstemmelse med direktiv 2014/53/EU. EU-overensstemmelseserklæringens fulde tekst kan findes på følgende internetadresse: **bmw-motorrad.com/certificates**

Croatian

LG ELECTRONICS INC. ovime izjavljuje da je radijska oprema tipa TL1P22 u skladu s Direktivom 2014/53/EU. Cjeloviti tekst EU izjave o sukladnosti dostupan je na sljede ico n jtern etskoj adresi: **bmw-motorrad.com/certificates**

Maltese

B'dan, LG ELECTRONICS INC., niddikjara li dan it-tip ta' tagħmir tar-radju TL1P22 huwa konformi mad-Direttiva 2014/53/UE. It-test kollu tad-dikjarazzjoni ta' konformità tal-UE huwa disponibbli f'dan l-indirizz tal-Internet li ġej: **bmw-motorrad.com/certificates**

Estonian

Käesolevaga deklareerib LG ELECTRONICS INC., et käesolev raadioseadme tüüp TL1P22 vastab direktiivi 2014/53/EL nõuetele. Eli vastavusdeklaratsiooni täielik tekst on kättesaadav järgmisel internetiaadressil: **bmw-motorrad.com/certificates**

Spanish

Por la presente, LG ELECTRONICS INC. declara que el tipo de equipo radioeléctrico TL1P22 es conforme con la Directiva 2014/53/UE. El texto completo de la declaración UE de conformidad está disponible en la dirección Internet siguiente: **bmw-motorrad.com/certificates**

Finnish

LG ELECTRONICS INC. vakuuttaa, että radiolaitetyyppi TL1P22 on direktiivin 2014/53/EU mukainen. EU-vaatimustenmukaisuusvakuutuksen täysimittainen teksti on saatavilla seuraavassa internetosoitteessa: **bmw-motorrad.com/certificates**

Slovak

LG ELECTRONICS INC. týmto vyhlasuje, že rádiové zariadenie typu TL1P22 je v súlade so smernicou 2014/53/EÚ. pln E vyhlásenie o zhode je k dispozícii na tejto internetovej adrese: **bmw-motorrad.com/certificates**

Portuguese

O(a) abaixo assinado(a) LG ELECTRONICS INC. declara que o presente tipo de equipamento de rádio TL1P22 está em conformidade com a Diretiva 2014/53/UE. O texto integral da declaração de conformidade está disponível no seguinte endereço de Internet: **bmw-motorrad.com/certificates**

Romanian

Prin prezenta, LG ELECTRONICS INC. declară că tipul de echipamente radio TL1P22 este în conformitate cu Directiva 2014/53/UE. Textul integral al declarației UE de conformitate este disponibil la următoarea adresă internet: **bmw-motorrad.com/certificates**

Swedish

Härmed försäkrar LG ELECTRONICS INC. att denna typ av radioutrustning TL1P22 verensstämmer med direktiv 2014/53/EU. Den fullständiga texten till EU-frskran om verensstämelse finns på ljust webbadress: **bmw-motorrad.com/certificates**

Latvian

Ar šo LG ELECTRONICS INC. deklarē, ka radioiekārta TL1P22 atbilst Direktīvai 2014/53/ES. Pilns ES atbilstības deklarācijas teksts ir pieejams šādā interneta vietnē: **bmw-motorrad.com/certificates**

Hungarian

LG ELECTRONICS INC.igazolja, hogy a TL1P22 típusú rádióberendezés megfelel a 2014/53/EU irányelvnek. Az EU-megfelelőségi nyilatkozat teljes szövege elérhető a következő internetes címen: **bmw-motorrad.com/certificates**

Italian

Il fabbricante, LG ELECTRONICS INC., dichiara che il tipo di apparecchiatura radio TL1P22 è conforme alla direttiva 2014/53/UE.

Il testo completo della dichiarazione di conformità UE è disponibile al seguente indirizzo Internet: **bmw-motorrad.com/certificates**

Lithuanian

Aš, LG ELECTRONICS INC., patvirtinu, kad radijo įrenginių tipas TL1P22 atitinka Direktyvą 2014/53/ES.

Visas ES atitikties deklaracijos tekstas prieinamas šiuo interneto adresu: **bmw-motorrad.com/certificates**

Polish

LG ELECTRONICS INC. niniejszym oświadcza, że typ urządzenia radiowego TL1P22 jest zgodny z dyrektywą 2014/53/UE.

Pełny tekst deklaracji zgodności UE jest dostępny pod następującym adresem internetowym: **bmw-motorrad.com/certificates**

280 INDEX

- A**
- Abbreviations and symbols, 4
- ABS
 - Engineering details, 164
 - Self-diagnosis, 148
 - Status indicators, 53
- Accessories
 - general notes, 210
- Active cruise control
 - Warning light, 58
- Adaptive Headlight, 176
- Ambient temperature
 - Display, 39
 - Outside temperature warning, 39
- Anti-theft alarm
 - Indicator light, 25
 - operating, 79
 - Warning light, 44
- Audio system
 - switching on and off, 128
 - Warning light, 58, 59
- Auxiliary headlights
 - Control, 22
 - operating, 75
- B**
- Battery
 - charging battery when connected, 200
 - charging battery when disconnected, 201
 - connecting to motor-cycle, 203
 - disconnecting from motorcycle, 202
 - Indicator light for vehicle voltage, 40, 41
 - installing, 204
 - Maintenance instructions, 200
 - Position on the vehicle, 21
 - removing, 203
 - Technical data, 230
- Bluetooth, 112
 - Helmet, 135
 - Pairing, 113
- Brake fluid
 - Checking fluid level, front, 186
 - Checking fluid level, rear, 188
 - Reservoir, front, 19
 - Reservoir, rear, 19
- Brake pads
 - checking front, 184
 - checking rear, 185
 - Running in, 150
- Brake temperature
 - Warning light, 57
- Brakes
 - ABS Pro in detail, 167
 - ABS Pro, 154
 - Adjusting handlebar levers, 139
 - Checking function, 184
 - Checking operation, 184
 - Safety information, 151
 - Technical data, 229
- C**
- Care
 - Chrome, 216
 - Paintwork preservation, 217
- Cases
 - operating, 94
- Central locking
 - Control, 23, 24
 - operating, 90
- Charging storage compartment
 - Position on the vehicle, 20

Chassis and suspension

- Technical data, 228

Check control

- Dialogue, 31

- Display, 31

Clock

- adjusting, 111

Clutch

- Adjusting handlebar

- levers, 139

- Checking operation, 189

- Fluid reservoir, 18

- Technical data, 227

Comfort turn indicators, 78

Communication systems

- Helmet, 135

Coolant

- Checking fill level, 189

- Fill-level indicator, 19

- Indicator light for overheating, 45

Cruise control

- Control, 22

- operating, 84

Currency, 6

D

Daytime riding lights

- automatic daytime riding

- light, 77

- Control, 22

- manual daytime riding

- light, 76

Diagnostic connector

- disengaging, 205

- Position on the vehicle, 21

- securing, 206

Dimensions

- Technical data, 232

Drop sensor

- Indicator light, 52

DTC

- Engineering details, 168

- Indicator and warning light, 54

- operating, 82

- Self-diagnosis, 149

DWA, 44

- Technical data, 231

Dynamic engine brake

- control, 169

Dynamic ESA

- operating, 82

E

Electrical system

- Technical data, 230

Emergency call

- Automatically in the event of a light fall, 73

- Automatically in the event of a severe fall, 73

- Control, 23

- Language, 72

- Notes, 11

- operating, 71

Emergency off switch (kill

- switch), 23, 24

- operating, 71

Engine, 46

- Indicator light for engine control, 47

- Indicator light for engine

- electronics, 46

- starting, 147

- Technical data, 226

- Warning light, drive

- malfunction, 46

282 INDEX

Engine oil

- Checking fill level, 182
- Electronic oil-level check, 44
- Filler neck, 19
- Indicator light for engine oil level, 45
- Oil dipstick, 19
- Technical data, 226
- topping up, 183

Equipment, 5

ESA

- Engineering details, 170

F

Favourites buttons, 124

- Assigning functions, 124
- Position on the vehicle, 20

Final drive

- Technical data, 228

Frame

- Technical data, 228

Front-wheel stand

- installing, 181

Fuel

- Filler neck, 20
- Fuel grade, 155
- refuelling, 156
- refuelling with Keyless Ride, 157, 158
- Technical data, 225

Fuel filler cap emergency

- release, 159, 160

Fuel reserve

- Range, 109
- Warning, 59

Fuses

- Position on the vehicle, 21
- replacing, 204
- Technical data, 230

G

General views

- Indicator and warning lights, 28
- Instrument cluster, 25
- Left multifunction switch, 22
- left side of vehicle, 18
- My vehicle, 116
- Right multifunction switch, 23, 24
- right side of vehicle, 19
- TFT display, 29, 30
- Underneath the seat, 21

H

Hazard warning flashers

- Control, 22
- operating, 74, 77

Headlight courtesy delay

- feature, 74

Heated handlebar grips

- operating, 91

Hill Start Control

- automatically deactivated, 56
- cannot be activated, 57
- Indicator and warning lights, 56

Hill Start Control Pro, 174

- Engineering details, 174
- operating, 87, 88

Horn, 22

I

Ignition

- Position on the vehicle, 20
- switching off, 65
- switching on, 64

Immobiliser

- Spare key, 68

Indicator lights, 25

- Overview, 28

Instrument cluster
 Ambient-light brightness sensor, 25
 Overview, 25

J

Jump-starting, 198

K

Keyless Ride, 40
 Battery of the radio-operated key is empty or loss of the radio-operated key, 69
 Engaging steering lock, 66
 Fuel filler cap, unlocking, 157, 158
 Switching off ignition, 67
 Switching on ignition, 66
 Warning light, 39, 40

Keys, 64, 65

L

Lighting
 Indicator light for faulty bulb, 42
 Replacing LED light sources, 198
 Technical data, 231
 Lights
 automatic daytime riding light, 77
 Control, 22
 Ground lighting, 75
 Headlight courtesy delay feature, 74
 Headlight flasher, 74
 High-beam headlight, 74
 Low-beam headlight, 74
 manual daytime riding light, 76

Parking lights, 75
 Side light, 74

Loudspeaker
 Relationship with Bluetooth, 130
 switching off, 131

Luggage

Instructions for loading, 144

M

Maintenance
 general notes, 180
 Maintenance schedule, 240
 Maintenance confirmations, 241
 Maintenance intervals, 238
 Media
 operating, 122
 Menu
 calling up, 106
 Mirrors
 adjusting, 138
 Mobility services, 238
 Motorcycle
 care, 212
 cleaning, 212
 lashing, 160
 laying up, 217
 parking, 154
 restoring to use, 217
 Multifunction switch
 Overview, left side, 22
 Overview, right side, 23, 24

N

Navigation
 operating, 120

O

On-board computer, 119

284 INDEX

- On-board voltage
 - Warning light, 40, 41
- P**
- Pairing, 113
- Parking, 154
- Phone
 - operating, 123
- Power socket
 - Notes on use, 210
 - Position on the vehicle, 18, 19
- Pre-Ride-Check, 148
- Pure Ride
 - Overview, 29
- R**
- Radio
 - Adding favourite, 130
 - Selecting source, 128
- RDC
 - Engineering details, 172
 - Warning indicators, 49, 51
- Rear-wheel stand
 - installing, 182
- Refuelling, 156
 - Fuel grade, 155
 - with Keyless Ride, 157, 158
- Remote control
 - Replacing battery, 69
- Rev. counter
 - Rev. counter, 109
- reverser, 89
 - Control, 22
- Riding mode
 - adjusting, 83
 - Control, 23, 24
 - Engineering details, 170
- Running in, 150
- S**
- Safety instructions
 - for brakes, 151
 - for riding, 144
- Satellite radio
 - Availability, 132
 - Calling up channels saved in memory, 134
 - Saving channel, 133
 - Selecting category and channel, 133
 - Signal strength, 133
 - Subscribing to channel, 132
 - System messages, 134
- Seat
 - installing, 94
 - removing, 94
 - Unlocking, 18
- Seat heating
 - operating, 91
- Service, 237
 - Reporting safety-relevant defects, 236
 - Service history, 237
- Service-due indicator, 60
- Shift assistant, 151, 173
 - Engineering details, 173
 - Gear not trained, 59
 - Riding, 151
- Shifting gear
 - Recommendation to upshift, 110
- slipstream deflector
 - operating, 93
 - Position on the vehicle, 18
- Spark plugs
 - Technical data, 231
- Speed Limit Info
 - Switching on or off, 108

- Splitscreen, 110
 - Selecting display, 110
 - switching off, 110
 - switching on, 110
- Starting, 147
 - Control, 23, 24
- Status line, top
 - adjusting, 107, 108
- Steering lock
 - Locking, 64
- Stowage compartment
 - operating, 96
 - Position on the vehicle, 18, 19
- T**
- Technical data
 - Anti-theft alarm, 231
 - Battery, 230
 - Brakes, 229
 - Bulbs, 231
 - Chassis and suspension, 228
 - Clutch, 227
 - Dimensions, 232
 - Electrical system, 230
 - Engine, 226
 - Engine oil, 226
 - Final drive, 228
 - Frame, 228
 - Fuel, 225
 - General notes, 5
 - Spark plugs, 231
 - Standards, 5
 - Transmission, 227
 - Weights, 232
 - Wheels and tyres, 229
- TFT display, 20, 25
 - Control, 22
 - operating, 106, 107, 110
 - Overview, 29, 30
 - Selecting display, 103
- Tone settings, 131
- Toolkit
 - Contents, 180
 - Position on the vehicle, 21
- Torques, 223
- Transmission
 - Technical data, 227
- Troubleshooting chart, 220
- Turn indicators
 - Control, 22
 - operating, 74, 78
- Type plate
 - Position on the vehicle, 19
- Tyre pressure monitoring RDC
 - Display, 48
- Tyres
 - Checking tread depth, 190, 191
 - Checking tyre pressure, 190
 - Pressures, 230
 - Recommendation, 190
 - Running in, 151
 - Technical data, 229
- V**
- Value
 - Display, 31
- Vehicle Identification Number
 - Position on the vehicle, 19
- Volume
 - Adapt to speed, 131
 - adjusting, 130

286 INDEX

W

- Warning indicator lights, 46
 - ABS, 53
 - Adaptive cruise control, 58
 - Anti-theft alarm, 44
 - Audio system, 58, 59
 - Brake temperature, 57
 - Bulb faulty, 42
 - Coolant temperature, 45
 - Drop sensor, 52
 - DTC, 54
 - DWA, 44
 - Engine control unit, 47
 - Engine electronics, 46
 - Engine oil level, 45
 - Fuel reserve, 59
 - Gear not trained, 59
 - Hill Start Control, 56, 57
 - Keyless Ride, 40
 - Light control failed, 43
 - Mode of presentation, 31
 - My vehicle, 116
 - On-board voltage, 40, 41
 - Outside temperature warning, 39
 - RDC, 49, 51
 - Warning light, drive malfunction, 46
- Warning light, drive malfunction, 46
- Warning lights, 25
 - Overview, 28
- Warnings, overview, 33
- Weights
 - Technical data, 232
- Wheels
 - Change of size, 191
 - Checking rims, 191
 - Installing front wheel, 194
 - Installing rear wheel, 197
 - Remove the front wheel, 192
 - Removing rear wheel, 196
 - Technical data, 229
- WIFI, 115
- Windscreen
 - adjusting, 138
 - Control, 22

Details described or illustrated in this booklet may differ from the vehicle's actual specification as purchased, the accessories fitted or the national-market specification. No claims will be entertained as a result of such discrepancies.

Dimensions, weights, fuel consumption and performance data are quoted to the customary tolerances.





The right to modify designs, equipment and accessories is reserved.

Errors and omissions excepted.

© 2021 Bayerische Motoren Werke Aktiengesellschaft
80788 Munich, Germany
Not to be reproduced by any means whatsoever, wholly or in part, without the written permission of BMW Motorrad, After Sales.
Original rider's manual, printed in Germany.

Important data for refuelling:

Fuel

Recommended fuel grade	 Premium unleaded (maximum 15 % ethanol,  E15) 95 ROZ/RON 90 AKI
Alternative fuel grade	 Regular unleaded (power- and consumption-related re- strictions) (max 15 % eth-  anol, E10/E15) 91 ROZ/RON 87 AKI
Usable fuel capacity	approx. 26.5 l
Reserve fuel	approx. 4 l
Tyre pressure	
Tyre pressure, front	2.9 bar, tyre cold
Tyre pressure, rear	2.9 bar, tyre cold

For further information on all aspects of your vehicle, visit: bmw-motorrad.com

