



BMW Motorrad



Rider's Manual (US Model)

K 1600 B

Motorcycle/Retailer Data

Motorcycle Data

Model

Vehicle identification number

Color number

Initial registration

License plate

Retailer Data

Contact in Service

Ms./Mr.

Phone number

Retailer's address/phone number (company stamp)

Welcome to BMW

Congratulations on choosing a motorcycle from BMW Motorrad and welcome to the community of BMW motorcycle owners and riders. Familiarize yourself with your new motorcycle so that you can ride it safely and confidently in all highway traffic situations.

About this Rider's Manual

Please read this Rider's Manual carefully before starting to use your new BMW. It contains important information on how to operate the controls and how to get the most benefit from your BMW's advanced technical features.

In addition, it contains information on maintenance and care to help you maintain your motorcycle's reliability and safety, as well as its value.

Documentation confirming performance of scheduled maintenance is a precondition for generous handling of out-of-warranty claims and goodwill warranty treatment.

Should you want to sell your BMW one day, please also remember to turn over the Ride's Manual to the new owner. It is an important part of your motorcycle.

Suggestions and complaints

If you have any questions concerning your motorcycle, your authorized BMW Motorrad retailer is always happy to provide advice and assistance.

We wish you many miles of safe and enjoyable riding on your BMW

BMW Motorrad.

01 40 9 467 307



Table of Contents

1 General instructions	5	3 Displays	23	Dynamic Traction Control (DTC)	72
Overview	6	Indicator and warning lights	24	Electronic chassis and suspension adjustment (D-ESA)	72
Abbreviations and symbols	6	Meaning of symbols.....	25	Riding mode	73
Equipment	7	Multifunction display	27	Cruise-control system.....	74
Technical Data	7	Warning lights	28	Hill Start Control	76
Notice concerning current status	7	4 Operation.....	49	Central locking system	77
Additional sources of information.....	8	Steering and ignition lock	50	Handle heat.	81
Certificates and operating permits	8	Ignition	50	Seat heating	82
Data memory.....	8	Ignition with Keyless Ride	51	Seat.....	83
2 Overviews	13	Emergency on/off switch (kill switch)	56	Storage compartments.....	84
General view, left side	15	Reverser	56	5 Setting	87
General view, right side	17	Lights	58	Mirrors	88
Underneath the seat	18	Hazard warning flashers.....	60	Windshield	88
Multifunction switch, left	19	Turn indicators	61	Wind deflection wing	89
Multifunction switch, right	21	Multifunction display	62	Clutch	89
Instrument cluster	22	On-board computer	66	Brakes	90
		Trip recorder	67	6 Riding.....	91
		Anti-theft alarm system (DWA).....	68	Safety information.....	92
				Observe checklist	94
				Always before riding off	94

At every third refueling stop	94				
Starting.....	94				
Breaking in	97				
Brakes	98				
Parking your motorcycle.....	100				
Refueling	100				
Securing motorcycle for transport	104				
7 Technology in detail.....	107				
General notes	108				
Antilock Braking System (ABS).....	108				
Dynamic Traction Control (DTC)	111				
Electronic chassis and suspension adjustment (D-ESA)	113				
Riding mode	113				
Tire pressure control (TPC/RDC)	115				
Shift assistant	116				
Hill Start Control	117				
8 Maintenance	119				
General instructions	120				
Tool kit	120				
Front wheel stand	120				
Engine oil	122				
Brake system	123				
Clutch	127				
Coolant.....	127				
Tires	128				
Rims and tires.....	129				
Wheels	129				
Light sources	136				
Jump-starting	141				
Battery	142				
Fuses	145				
Diagnostic connector.....	146				
9 Accessories	149				
General notes	150				
Onboard power outlets....	150				
Case	151				
Navigation device	152				
10 Care	157				
Care products	158				
Washing your motorcycle.....	158				
Cleaning sensitive motorcycle parts.....	159				
Paint care	160				
Protective wax coating	160				
Store motorcycle.....	160				
Return motorcycle to use	160				
11 Technical data	161				
Troubleshooting chart.....	162				
Threaded fasteners	163				
Fuel	164				
Engine oil	164				
Engine	165				
Clutch	166				
Transmission.....	166				
Rear-wheel drive	167				
Frame	167				
Suspension	168				
Brakes	168				
Wheels and tires	169				
Electrical system	171				

Anti-theft alarm system ...	173	Certificate for Tire Pressure	
Dimensions	174	Control	210
Weights	174	14 Index	211
Performance data	175		
12 Service	177		
Reporting safety			
defects	178		
BMW Motorrad Service ...	179		
BMW Motorrad Service			
History	179		
BMW Motorrad Mobility			
Services.....	180		
Maintenance proce-			
dures.....	180		
Maintenance schedule ...	183		
Maintenance confirma-			
tions.....	184		
Service confirmations	198		
13 Appendix.....	201		
Certificate for Electronic			
Immobilizer	202		
Certificate for Remote			
Key.....	204		
Certificate for Key-			
less Ride	208		

General instructions

Overview	6
Abbreviations and symbols	6
Equipment	7
Technical Data	7
Notice concerning current status	7
Additional sources of information	8
Certificates and operating permits ...	8
Data memory	8

Overview

Chapter 2 of this Rider's Manual will provide you with an initial overview of your motorcycle. All maintenance and repair work carried out on your motorcycle will be documented in Chapter 12. Documentation confirming performance of scheduled maintenance is a precondition for generous handling of out-of-warranty claims and goodwill warranty treatment.

When the time comes to sell your BMW, please remember to hand over this Rider's Manual; it is an important part of the motorcycle.

Abbreviations and symbols

 **CAUTION** Hazard with low risk. Failure to avoid this hazard can result in minor or moderate injury.

 **WARNING** Hazard with moderate risk. Failure to avoid this hazard can result in death or serious injury.

 **DANGER** Hazard with high risk. Failure to avoid this hazard results in death or serious injury.

 **ATTENTION** Special instructions and precautionary measures. Non-compliance can cause damage to the vehicle or accessories and warranty claims may be denied as a result.

 **NOTICE** Special information on operating and inspecting your motorcycle as well as maintenance and adjustment procedures.

◀ Indicates the end of an item of information.

• Instruction.

» Result of an activity.

▬➔ Reference to a page with more detailed information.

◁ Indicates the end of accessory or equipment-dependent information.

 Tightening torque.

 Technical data.

ABS Anti-Lock Brake System.

D-ESA Electronic chassis and suspension adjustment.

DTC Dynamic Traction Control.

DWA Anti-theft alarm.

EWS Electronic immobilizer.

- NV National-market version.
- OE Optional extra.
BMW Motorrad optional extras are already completely installed during motorcycle production.
- OA Optional accessory.
BMW Motorrad optional accessories can be purchased and installed at your authorized BMW Motorrad retailer.
- TPC Tire Pressure Control (TPC).

Equipment

When you ordered your BMW motorcycle, you chose various custom equipment items. This Rider's Manual describes optional equipment (OE) offered by BMW and selected optional

accessories (OA). This explains why the manual may also contain descriptions of equipment which you have not ordered. Please note, too, that your motorcycle might not be exactly as illustrated in this manual on account of country-specific differences. If your motorcycle features equipment that is not described here, you can find these features described in a separate manual.

Technical Data

All dimensions, weights and performance data contained in this Rider's Manual refer to the German DIN standards and comply with their tolerance specifications. The technical data and specifications in this Rider's Manual serve as points of reference. The vehicle-specific data may vary, for instance due to the selected optional equipment, national-market version or country-specific

measuring procedures. Detailed values can be obtained from the registration documents and the signs on the vehicle or from your authorized BMW Motorrad retailer or other qualified service partner or specialist workshop. The information on the vehicle documents always takes precedence over the information in this Rider's Manual.

Notice concerning current status

The high safety and quality standards of BMW motorcycles are maintained by consistent, ongoing development efforts embracing their design, equipment and accessories. For this reason, some aspects of your motorcycle may vary from the descriptions in these operating instructions. In addition, BMW Motorrad cannot guarantee the total absence of errors. We hope you will ap-

preciate that no claims can be recognized based on the data, illustrations or descriptions in this manual.

Additional sources of information

BMW Motorrad retailers

Your BMW Motorrad retailer is always happy to answer any of your questions.

Internet

The Rider's Manual for your vehicle, the operating and installation instructions for optional accessories and general BMW Motorrad information related to the technology or other features are available at **www.bmw-motorrad.com/service**.

Certificates and operating permits

The certificates for the vehicle and the official operating permits for possible accessories are available at **www.bmw-motorrad.com/certification**.

Data memory

General

Electronic control units are installed in the vehicle. Electronic control units process data received from vehicle sensors, self-generated data or data exchanged between control units, for example. Some control units are required for safe vehicle operation or provide driving assistance, such as driver assistance systems. Control units also make comfort and infotainment functions possible.

Information about the stored or exchanged data can be obtained

from the vehicle manufacturer, such as in the form of a separate booklet.

Personal references

Every vehicle is marked with a unique vehicle identification number. Depending on the country, the vehicle owner can be identified using the vehicle identification number and registration number and the help of the relevant authorities. There are also other ways to trace data obtained from the vehicle back to the driver or vehicle owner, such as via the used ConnectedDrive Account.

Data privacy laws

In accordance with applicable data privacy laws, vehicle users have certain rights over the vehicle manufacturer or company that collects or processes personal data.

Vehicle users have the right to obtain comprehensive information without charge from the locations that store the vehicle user's personal data.

These locations may be:

- The vehicle manufacturer
- Qualified service partners
- Specialist workshops
- Service providers

Vehicle users may request information about the type of personal data that is stored, the purpose for which the data will be used and the source of the data. This information can only be obtained by a registered owner or a person with written proof authorizing use of the vehicle.

The right to information also includes information related to data transmitted to other companies or locations.

The vehicle manufacturer's website contains the appropriate pri-

vacancy policy notices. The privacy policy notices contain information on the right to delete or correct data. The vehicle manufacturer also provides the manufacturer contact information and the contact information of the data security officer.

The vehicle owner can have a BMW Motorrad retailer or other qualified service partner or specialist workshop read out the data stored in the vehicle for a fee if required.

The vehicle data is read out via the power socket required by law for on-board diagnosis (OBD) in the vehicle.

Legal requirements for the disclosure of data

The vehicle manufacture is required by the law applicable in this context to provide authorities with the data stored by the manufacturer. Providing this data

within the scope required is on a case-by-case basis, for instance to clarify a criminal offense.

Government agencies are authorized by the law applicable in this context to read out the data from the vehicle themselves in individual cases.

Operating data in the vehicle

Control units process data so that the vehicle can run.

Examples of these include:

- Status messages from the vehicle and its individual components, such as wheel RPM, wheel speed and deceleration
- Environmental conditions, such as temperature

The data is processed only in the vehicle itself and is usually temporary. The data is not stored beyond the period in which the vehicle is operating.

Electronic components such as control units contain components for storing technical information. This may be information about the vehicle's condition, component load, events or faults stored temporarily or permanently.

This information generally documents the condition of a component, module, system or the surrounding area; for example:

- Operating conditions of system components, such as fill levels and tire pressure
- Malfunctions and faults in key system components, such as lights and brakes
- Vehicle responses in specific driving situations, such as activation of dynamic driving systems
- Information about events causing damage to the vehicle

The data is necessary for providing control unit functions. In

addition, it is used by the vehicle manufacturer to detect and eliminate malfunctions as well as to optimize vehicle functions.

The majority of this data is temporary and is processed only within the vehicle itself. Only a small amount of event-driven data is stored in the event data recorder and fault memory.

When a vehicle is serviced, such as for repairs, servicing processes, warranty cases and quality assurance measures, this technical information can be read out from the vehicle together with the vehicle identification number.

The information can be read out by a BMW Motorrad retailer or other qualified service partner or specialist workshop. The power socket required by law for on-board diagnosis (OBD) in the vehicle is used to read out the data.

The data is collected, processed and used by the respective service network locations. The data documents the vehicle's technical states and helps with fault finding, compliance with warranty obligations and quality improvements.

The manufacturer also has product monitoring obligations arising from product liability law. The vehicle manufacturer requires technical data from the vehicle in order to fulfill these obligations. The data from the vehicle can also be used to verify customer warranty and guarantee claims. The fault memory and event data recorder in the vehicle can be reset by a BMW Motorrad retailer or other qualified service partner or specialist workshop as part of repair work or servicing.

Data input and data transfer in the vehicle

General

Depending on the equipment, comfort settings and individualized settings in the vehicle can be saved and changed or reset at any time.

Examples of these include:

- Windshield position settings
- Chassis and suspension adjustment settings

It is possible to introduce data into the vehicle entertainment and communication system via a smartphone, for instance.

Depending on the individual equipment, this includes:

- Multimedia data, such as music for playback
- Address book data for use in conjunction with a communication system or integrated navigation system
- Entered navigation destinations

- Data about the use of internet services. This data can be stored locally in the vehicle or is on a device connected to the vehicle, such as a smartphone, USB stick or MP3 player. If this data is saved in the vehicle, it can be deleted at any time.

This data is transmitted to third parties only upon personal request as part of the use of online services. The data transmitted depends on the selected settings when using the services.

Integrating mobile end devices

Depending on the equipment, mobile end devices connected to the vehicle, such as smartphones, are controlled using the vehicle's controls.

This enables audio and visual output from mobile end devices through the multimedia system. At the same time, certain infor-

mation is transmitted to the mobile end device. This includes for instance position data and other general vehicle data, depending on the type of integration, and makes it possible to optimize the use of selected apps, such as those for navigation or music playback.

The way the data is processed further is determined by the provider of the particular app used. The range of possible settings depends on the particular app and the operating system of the mobile end device.

Services

General

If the vehicle has a mobile phone connection, this connection makes it possible to exchange data between the vehicle and other systems. The mobile phone connection is made possible through the vehicle's

transmitter and receiver or via personally integrated mobile end devices such as smartphones.

Online functions, as they are called, are used over this mobile phone connection. These include online services and apps provided by the vehicle manufacturer or other providers.

Vehicle manufacturer services

In the case of the vehicle manufacturer's online services, the particular functions are described at the appropriate location, such as in the Rider's Manual or on manufacturer's website. The relevant legal information on data privacy is also provided there. Personal data may be used in order to provide online services. The data is exchanged over a secure connection, i.e. with the vehicle manufacturer's IT systems which are intended for this purpose.

Any collection, processing and use of personal data that goes beyond the provision of services take place only as permitted by law, on the basis of a contractual agreement or as a result of consent. It is also possible to have the entire data connection activated or deactivated. This is not the case for legally prescribed functions.

Services of other providers



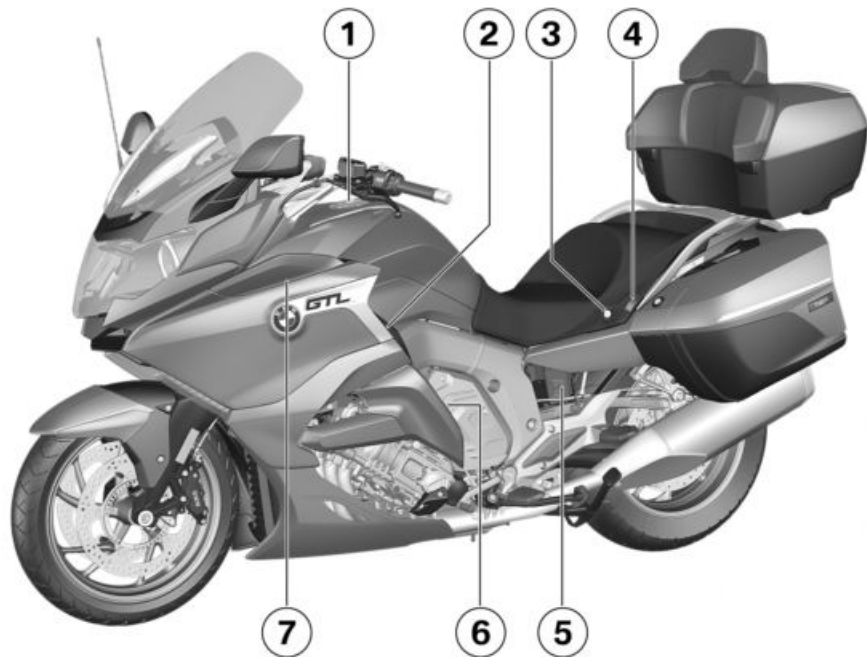

When using the online services of other providers, these services are subject to the responsibility and the data protection and usage conditions of the respective provider. The vehicle manufacturer has no control over the content exchanged via these services. Information about the type, scope and purpose of collecting and using personal data as part of third-party services can be obtained from the particular service provider.

Overviews

General view, left side.....	15
General view, right side	17
Underneath the seat	18
Multifunction switch, left	19
Multifunction switch, right.....	21
Instrument cluster	22







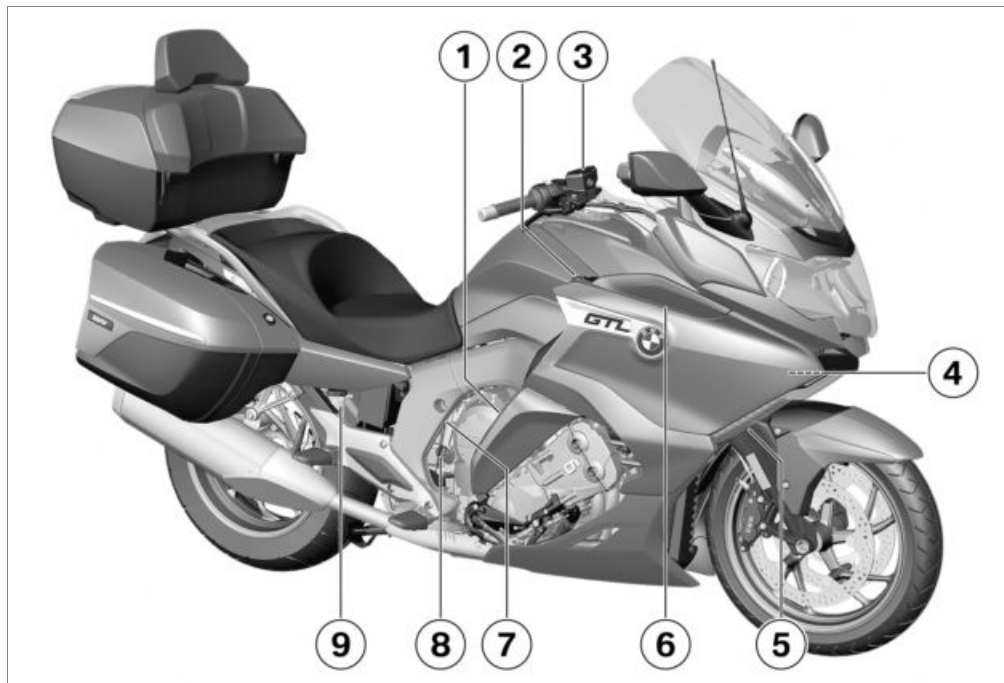

General view, left side

- 1** Fuel filler opening
( 101)
- 2** Operating panel for the audio system (see separate operating instructions)
- 3** Seat lock ( 83)
- 4** Passenger seat heating rocker switch ( 82)
- 5** Load capacity table
Tire inflation pressure table
- 6** Storage compartment
( 84)
- 7** Wind deflection wing
( 89)



General view, right side

- 1 Storage compartment
( 84)
- 2 Power socket ( 150)
- 3 Brake-fluid reservoir, front
( 125)
- 4 Coolant level indicator (behind side panel) ( 127)
- 5 Type plate (on the front suspension)
- 6 Wind deflection wing
( 89)
- 7 Engine number (above the engine oil filler opening)
Vehicle identification number (above the engine oil filler opening on the rear main frame side section)
- 8 Engine oil filler opening and oil dipstick ( 122)
- 9 Brake-fluid reservoir, rear
( 126)

Underneath the seat

- 1 Rider's Manual (US Model)
- 2 Fuses (➡ 145)
- 3 Battery (➡ 142)
- 4 Standard tool kit (➡ 120)
- 5 Data link connector (➡ 146)

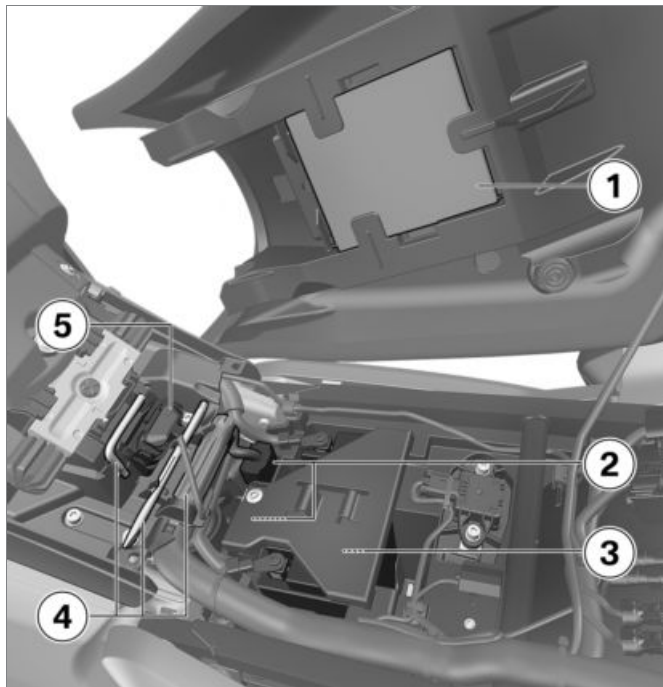

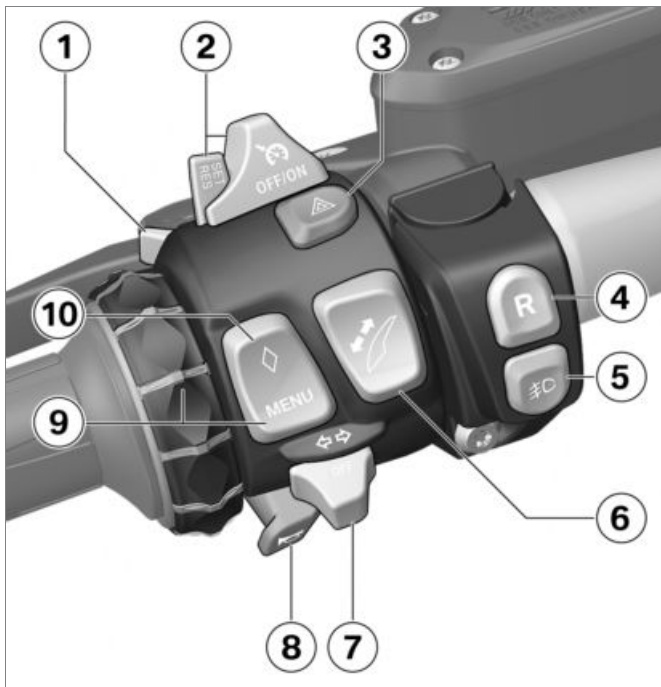

Multifunction switch, left

- 1 High beam and headlight flasher (➡ 58)
- 2 Cruise control (➡ 74)
- 3 Hazard warning lights system (➡ 60)
- 4 – with reverser^{OE}
Reverser (➡ 57).
- 5 – with additional headlight^{OE}
Additional headlight (➡ 59).
- 6 Windshield (➡ 88)
- 7 Turn indicators (➡ 61)
- 8 Horn
- 9 Multi-Controller and MENU button
Multifunction display (➡ 62)
Audio system (see corresponding rider's manual)
DTC (➡ 72)
D-ESA (➡ 72)

- 10 Selecting the Favorite menu (☰→ 65).



Multifunction switch, right

- 1 – with central locking system^{OE}
Central locking system (➡ 77).
- 2 Select riding mode (➡ 73)
- 3 Emergency on/off switch (kill switch) (➡ 56)
- 4 Starting engine (➡ 94)

Instrument cluster

- 1 Speedometer
- 2 Release for navigation bay
- 3 Indicator and warning lights (►► 24)
- 4 – with audio system US
version with navigation
preparation^{OE}
– with navigation system^{OA}
Navigation device
(►► 152).
- 5 Photosensor (for adjusting
brightness of instrument
lighting)
- 6 Tachometer
- 7 Multifunction display
(►► 27)



NOTICE

The brightness of the indicator and warning lights, the display and the instrument needle and gage lighting is adapted automatically to suit ambient brightness. ◀

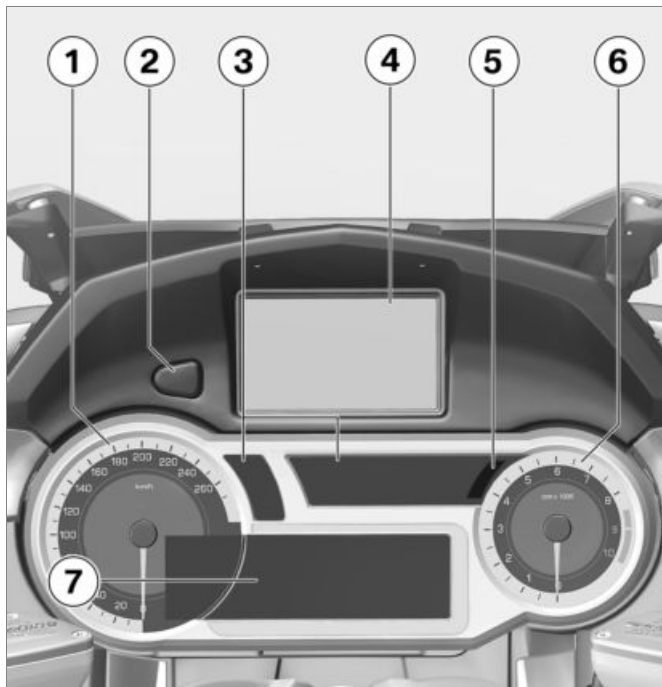

Displays

Indicator and warning lights	24
Meaning of symbols	25
Multifunction display	27
Warning lights	28

Indicator and warning lights

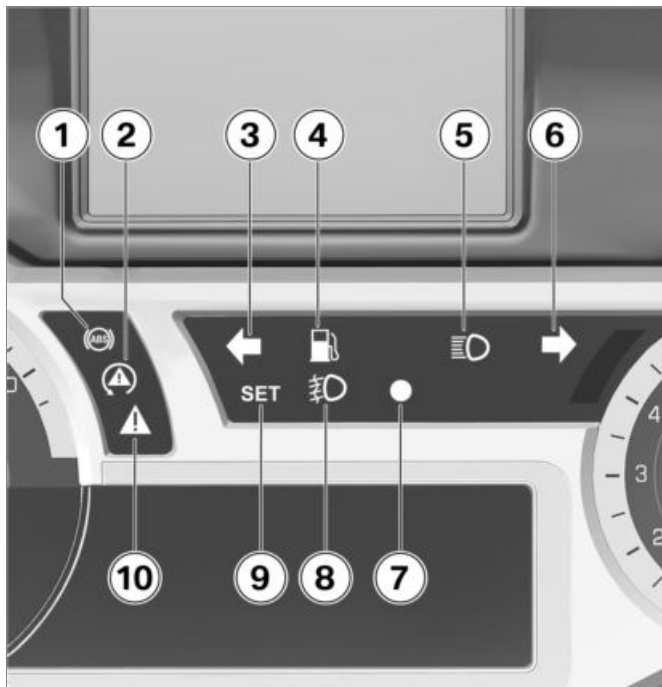

- 1 ABS (▮▮▮ 44)
- 2 DTC (▮▮▮ 44)
- 3 Turn indicator, left
- 4 Fuel reserve (▮▮▮ 46)
- 5 High beam
- 6 Turn indicator, right
- 7 Anti-theft alarm system (▮▮▮ 68)
- 8 Additional headlight (▮▮▮ 59)
- 9 Cruise control (▮▮▮ 74)
- 10 General warning light, in conjunction with warning symbols on display (▮▮▮ 28)





Meaning of symbols



Meaning of the symbols at position **1**:

-  Average fuel consumption since last reset (➡ 66)
-  Current fuel consumption
-  Range with fuel quantity now on board (➡ 45)

 Average speed since last reset (➡ 66)

 Ambient temperature (➡ 35)

– with tire pressure monitor (TPM)^{OE}

 Tire pressures (➡ 38)

 Stopwatch (➡ 67)

 Travel times (➡ 67)

 Date (display mode depends on the time format selected) (➡ 65)

 Vehicle voltage

 Oil level (➡ 37)



2 Passenger seat heating turned on

3 Heated grips turned on

4 Rider's seat heating turned on



5 Damping

6 Vehicle load

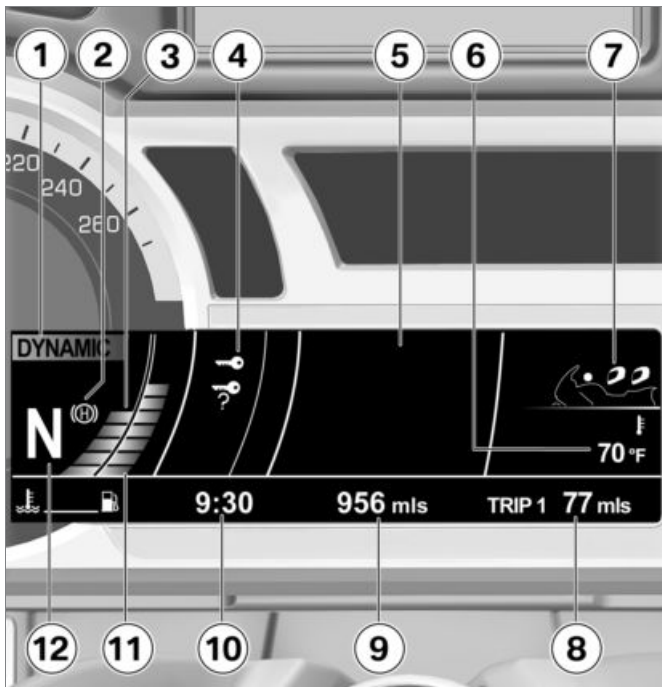

Multifunction display

- 1 Riding mode (►► 73)
- 2 Using Hill Start Control Pro (►► 76).
- 3 Coolant temperature
- 4 Warning lights (►► 28)
- 5 Menu panel (►► 62)
Area for messages relating to the audio system
- 6 Onboard computer (►► 66)
– with tire pressure monitor (TPM)^{OE}
TPM readings
- 7 Seat heating (►► 82)
Heated handlebar grips (►► 81)
D-ESA settings (►► 72)
- 8 Trip distance (►► 67)
- 9 Total distance covered
- 10 Clock (►► 65)
- 11 Fuel level
- 12 Gear indicator

Warning lights

Display

Warnings are displayed with the corresponding warning lamps.

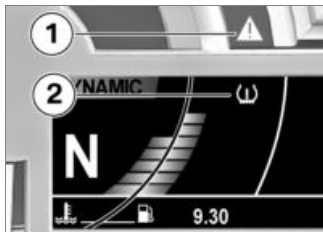











Warnings for which there is no dedicated warning light are indicated by 'General' warning light **1** showing in combination with a warning symbol such as, for example, **2** appearing in the multifunction display. The universal warning lamp shows red or yellow, depending on the urgency of the warning.













Up to four warning symbols can be displayed at any given time. The universal warning lamp lights up for the most urgent warning. The possible warnings are listed on the following pages.

Indicator and warning lights

Display text

Meaning









	The general warning lamp flashes yellow.		The engine symbol appears on the display.	Severe engine fault (→ 37)
			The oil can symbol is displayed.	Engine-oil level too low (→ 38)
	The general warning light flashes red.		The tire symbol is displayed. The critical tire pressure is displayed in red.	Tire inflation pressure is outside approved range (→ 38)
	The general warning light lights up yellow.		The tire symbol and "--" or "-- --" are displayed.	Sensor defective or system fault (→ 39)
			The tire symbol and "--" or "-- --" are displayed.	Transmission fault (→ 39)
	The general warning light lights up yellow.		The TPM battery symbol appears on the display.	Battery of tire-inflation pressure sensor weak (→ 40)

Indicator and warning lights	Display text	Meaning
 The general warning light lights up red.	 Headlamp with question mark appears on the display.	Light direction of the low-beam headlight not known (▬▬▬ 40)
 The general warning lamp flashes yellow.	 Headlamp with zero appears on the display.	Beam-throw adjustment of the low-beam headlight restricted (▬▬▬ 41)
 The general warning light lights up yellow.	 Headlamp with Left/Right appears on the display.	Headlight aiming changed (▬▬▬ 41)
 The general warning light lights up yellow.	 Bulb symbol with arrow pointing to the rear appears on the display.	Rear light failure (▬▬▬ 41)
 The general warning light lights up yellow.	 Bulb symbol with arrow pointing to the front appears on the display.	Front light failure (▬▬▬ 41)
 The general warning light lights up yellow.	 Bulb symbol with two arrows appears on the display.	Light failure (▬▬▬ 42)

Indicator and warning lights

Display text









Meaning

		 The split battery symbol appears on the display.	Onboard system voltage low (▬▬▬▶ 42)
	The general warning light lights up yellow.	 The split battery symbol appears on the display.	Onboard system voltage critical (▬▬▬▶ 42)
	The general warning light lights up red.	 The battery symbol is displayed.	Battery charge current insufficient (▬▶ 42)
		 The anti-theft alarm system battery symbol appears on the display.	Anti-theft alarm battery low charge (▬▬▶ 43)
	The general warning light lights up yellow.	 The anti-theft alarm system battery symbol appears on the display.	Anti-theft alarm battery drained (▬▬▶ 43)
		 The locked symbol appears on the display.	Central locking locked (▬▶ 44)

Indicator and warning lights

Display text











Meaning

	The ABS indicator and warning light flashes.		ABS self-diagnosis not completed (▬▬▬▶ 44)
	The ABS indicator and warning light light up.		ABS error (▬▬▬▶ 44)
	The DTC indicator light flashes rapidly.		DTC intervention (▬▬▶ 44)
	The DTC indicator light flashes slowly.		DTC self-diagnosis not completed (▬▬▬▶ 44)
	The DTC indicator light lights up.		DTC deactivated (▬▬▶ 45)
	The DTC indicator light lights up.		DTC error (▬▬▶ 45)
	The general warning light lights up yellow.		The D-ESA fault symbol is displayed. D-ESA fault (▬▬▶ 45)

Indicator and warning lights

Display text

Meaning

	Fuel reserve symbol lights up.	The fuel-level reading is displayed in yellow.	Fuel down to reserve (►►► 46)
			Hill Start Control Pro active (►►► 46)
	The general warning lamp flashes yellow.		Hill Start Control Pro is automatically deactivated (►►► 46)
	The general warning lamp flashes yellow.		Hill Start Control Pro cannot be activated (►►► 47)
	The general warning light lights up yellow.		Brake temperature too high (►►► 47)
	The general warning light briefly lights up yellow.		Service overdue (►►► 48)

Ambient temperature



Engine heat can lead to spurious readings of ambient temperature when the motorcycle is stationary. When the effects of engine heat on the monitored temperature become excessive the display responds by temporarily reverting to "--" as the display reading.



If the ambient temperature drops below 37 °F (3 °C), this warning of possible ice formation appears. The display automatically switches from any other mode to the temperature reading when the temperature drops below this threshold for the first time.

Outside temperature warning



The ice crystal symbol is displayed.

Possible cause:

The ambient temperature measured at the vehicle is lower than 37 °F (3 °C).



WARNING

Risk of black ice, even above 37 °F (3 °C)

Accident hazard

- At a low outside temperature, icy conditions must be expected on bridges and in shady road areas. ◀
- Think well ahead when driving.

Electronic immobilizer is active



The general warning light lights up yellow.



The key symbol is displayed.

Possible cause:

The key being used is not authorized for starting, or communication between the key and engine electronics is disrupted.

- Remove other motorcycle keys from the ignition key ring.
- Use the reserve key.
- Have the defective key replaced, preferably by an authorized BMW Motorrad retailer.

Radio-operated key outside reception range

– with Keyless Ride^{OE}



The "remote key outside reception area" symbol is displayed.

Possible cause:

Communication between the key fob transmitter and the engine electronics is disrupted.

- Check the battery in the key fob transmitter.

- Use the wallet key for further driving.

– with Keyless Ride^{OE}

- Battery of the key fob transmitter is empty or the key fob transmitter is lost (→ 54).
- Should the warning symbol appear while driving, keep calm. You can continue driving; the engine will not turn off.
- Have the defective key fob transmitter replaced by an authorized BMW Motorrad retailer.

Replace battery of radio-operated key

– with Keyless Ride^{OE}



The battery symbol is displayed.

Possible cause:

- The battery for the key fob transmitter is no longer charged to full capacity. Operation of the key fob transmitter is only ensured for a limited time.

Coolant temperature too high



The general warning light lights up red.

The temperature display is shown in red.



ATTENTION

Riding with overheated engine

Engine damage

- Be sure to observe the measures listed below. ◀

Possible cause:

The coolant temperature is too high.

- If possible, continue driving in the part-load range to cool down the engine.
- In traffic jams, switch off the engine, but keep the ignition switched on so that the radiator fan continues to operate.
- Should the coolant temperature frequently be too high, have the fault rectified as quickly as possible by an authorized workshop, preferably an authorized BMW Motorrad retailer.

Engine fault



The general warning light lights up yellow.



The engine symbol appears on the display.

Possible cause:

The engine control unit has diagnosed a fault.



WARNING

Unusual handling when the engine is in emergency operation

Accident hazard

- Avoid rapid acceleration and passing maneuvers. ◀
- The engine may behave unexpectedly with continued driving (low power, poor response characteristics, abrupt stalling and the like).
- Have the malfunction corrected as soon as possible at an authorized service facility, preferably an authorized BMW Motorrad Retailer.

Severe engine fault



The general warning lamp flashes yellow.



The engine symbol appears on the display.

Possible cause:

The engine control unit has diagnosed a serious fault.



WARNING

Damage to engine during emergency operation

Accident hazard

- Drive slowly and avoid rapid acceleration and passing maneuvers.
- If possible, have the vehicle picked up and the fault eliminated at a specialist workshop, preferably an authorized BMW Motorrad retailer. ◀
- The engine may behave unexpectedly with continued driving (low power, poor response

characteristics, abrupt stalling and the like).

- Have the malfunction corrected as soon as possible at an authorized service facility, preferably an authorized BMW Motorrad Retailer.

Oil level indicator



The oil-level indicator gives you an indication of the engine oil level.

The conditions for the oil level indicator are as follows:

- Engine at operating temperature.
- Engine idling for at least ten seconds.
- Side stand retracted.
- Motorcycle is vertical.

The readings mean:

OK: oil level correct.

CHECK!: check oil level during next refueling stop.

-- -: no measurement possible (above-mentioned conditions not met).

Engine-oil level too low



The oil can symbol is displayed.

Possible cause:

The electronic oil level sensor has detected that the engine's oil level is too low. Check the engine oil level with the dipstick the next time you stop to refuel:

- Check engine oil level (➡ 122).

If oil level is too low:

- Topping up engine oil (➡ 123).

Tire pressures

– with tire pressure monitor (TPM)^{OE}

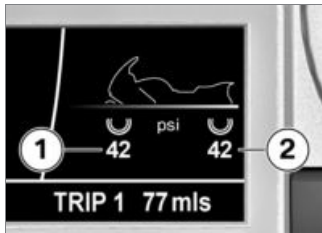

The displayed tire pressures refer to a tire temperature of 68 °F (20 °C). The figure on the left side **1** indicates the front tire's inflation pressure, while the figure on the right **2** shows the inflation pressure in the rear tire. "-- --" is displayed after the ignition is switched on, as the tire pressure values are not transmitted until a speed of 19 mph (30 km/h) is exceeded for the first time.

If the pressure in a tire drops to a critical level, the corresponding display shows red.



The tire warning symbol also appears on the display.



The general warning light flashes red.

Additional information about the BMW Motorrad TPM is provided starting on page (➡ 115).

Tire inflation pressure is outside approved range

– with tire pressure monitor (TPM)^{OE}



The general warning light flashes red.



The tire symbol is displayed. The critical tire pressure is displayed in red.

Possible cause:

The measured tire inflation pressure is outside the approved tolerance range.

- Check tire for damage and suitability for continued use.

If it is still possible to drive with tire:

WARNING

Tire pressure is outside the approved tolerance range.

Risk of accident, deterioration in the handling characteristics of the vehicle.

- Adjust the driving style.◀
- Correct tire inflation pressure at the next opportunity.

NOTICE

Before adjusting the tire pressure, check the information on temperature compensation and tire pressure adjustment in the "Technology in detail" section:◀

- Have the tire checked for damage at an authorized service facility, preferably an authorized BMW Motorrad retailer.

If you are unsure about the tire's suitability for continued riding:

- Do not continue riding.
- Contact roadside service.

Sensor defective or system fault

– with tire pressure monitor (TPM)^{OE}

 The general warning light lights up yellow.

 The tire symbol and "--" or "-- --" are displayed.

Possible cause:

Wheels without TPM sensors are fitted.

- Retrofit wheel set with TPM sensors.

Possible cause:

One or two TPM sensors have failed.

- Have fault eliminated at a specialist service facility, preferably an authorized BMW Motorrad retailer.

Possible cause:

A system fault has occurred.

- Have fault eliminated at a specialist service facility, preferably an authorized BMW Motorrad retailer.

Transmission fault

– with tire pressure monitor (TPM)^{OE}

 The tire symbol and "--" or "-- --" are displayed.

Possible cause:

The motorcycle's speed has not exceeded the threshold of approx. 19 mph (30 km/h). The TPM sensors do not send their

signal until after this speed has been exceeded for the first time (►► 115).

- Observe the TPM display at higher speed. Only when the general warning light also lights up is this a permanent fault. In this case:
- Have fault eliminated at a specialist service facility, preferably an authorized BMW Motorrad retailer.

Possible cause:

There is a fault in the radio connection to the TPC/RDC sensors. Possible causes are radio systems in the surrounding area, which interfere with the connection between the TPC/RDC control unit and the sensors.

- Watch the TPC/RDC display in another environment. A continuous error is only present if the general warning lamp also lights up. In this case:

- Have fault eliminated at a specialist service facility, preferably an authorized BMW Motorrad retailer.

Battery of tire-inflation pressure sensor weak

– with tire pressure monitor (TPM)^{OE}



The general warning light lights up yellow.



The TPM battery symbol appears on the display.



NOTICE

This fault message is only shown for a short time immediately following the Pre-Ride-Check. ◀

Possible cause:

The battery for the tire pressure sensor is no longer charged to full capacity. Operation of the tire

pressure control is only ensured for a limited time.

- Contact an authorized service facility, preferably an authorized BMW Motorrad retailer.

Light direction of the low-beam headlight not known



The general warning light lights up red.



Headlamp with question mark appears on the display.

Illumination of the road ahead is no longer optimum; there is a possibility of dazzling oncoming traffic.

Possible cause:

Light direction and range of the low beams are unknown, and adjustment is no longer possible.

- If it is dark, leave the motorcycle where it is or have it picked up, if possible.

- Have defect corrected as soon as possible by an authorized workshop, preferably an authorized BMW Motorrad retailer.

Beam-throw adjustment of the low-beam headlight restricted



The general warning lamp flashes yellow.



Headlamp with zero appears on the display.

Illumination of the road ahead is no longer optimum.

Possible cause:

Only restricted adjustment of light direction and range of the low beams is possible.

- Have the defect rectified by a specialist workshop, preferably an authorized BMW Motorrad retailer.

Headlight aiming changed

– with Adaptive Lights^{OE}



Headlamp with Left/Right appears on the display.

Cornering light control for the low-beam headlight is switched off.

Possible cause:

Headlight alignment has been changed from the as-delivered condition.

- Setting right- or left-hand traffic (→ 59).

Rear light failure



The general warning light lights up yellow.



Bulb symbol with arrow pointing to the rear appears on the display.

Possible cause:

Rear light, brake light or rear flashing turn indicator defective. The LED tail light must be replaced.

- Please contact a specialized workshop, preferably an authorized BMW Motorrad retailer.

Front light failure



The general warning light lights up yellow.



Bulb symbol with arrow pointing to the front appears on the display.

Possible cause:

Low beams, high beams, parking lamps or turn signal faulty. The low beams or one of the LED turn signals must be replaced.

- Please contact a specialist service facility, preferably an authorized BMW Motorrad Retailer.

- Replacing high beam light source (➔ 136).

Light failure

 The general warning light lights up yellow.

 Bulb symbol with two arrows appears on the display.

Possible cause:

A combination of light failures has occurred.

- Please contact a specialized workshop, preferably an authorized BMW Motorrad retailer.

Onboard system voltage low

 The split battery symbol appears on the display. Generator power is only just sufficient to supply all consumers and charge the battery.

Possible cause:

Too many consumers switched on. On-board system voltage tends to drop particularly at low engine rpm and when the engine is idling.

- When riding at low engine rpm switch off consumers that are not necessary for road safety (e.g. heated body warmer or auxiliary headlights).

Onboard system voltage critical

 The general warning light lights up yellow.

 The split battery symbol appears on the display.

Generator power is no longer sufficient to supply all consumers and charge the battery. In order to ensure that the engine can be started and the motorcycle ridden, the onboard electronics switch off the electricity supply

to the onboard sockets and the auxiliary headlights. In extreme cases the seat heating and the grip heating might also be shut down.

Possible cause:

Too many consumers switched on. On-board system voltage tends to drop particularly at low engine rpm and when the engine is idling.

- When riding at low engine rpm switch off consumers that are not necessary for road safety (e.g. heated body warmer or auxiliary headlights).

Battery charge current insufficient

 The general warning light lights up red.

 The battery symbol is displayed.

WARNING

Failure of vehicle systems

Accident hazard

- Do not continue riding.◀

The battery is not being charged. If you continue driving, the vehicle electronics will discharge the battery.

Possible cause:

Alternator or alternator drive faulty.

- Have the malfunction corrected as soon as possible at an authorized service facility, preferably an authorized BMW Motorrad Retailer.

Anti-theft alarm battery low charge

– with anti-theft alarm system (DWA)^{OE}



The anti-theft alarm system battery symbol appears on the display.



NOTICE

This fault message is only shown for a short time immediately following the Pre-Ride-Check.◀

Possible cause:

The anti-theft alarm battery no longer has its full capacity. The operation of the anti-theft alarm system is only ensured for a limited time with the motorcycle battery disconnected.

- Contact an authorized service facility, preferably an authorized BMW Motorrad retailer.

Anti-theft alarm battery drained

– with anti-theft alarm system (DWA)^{OE}



The general warning light lights up yellow.



The anti-theft alarm system battery symbol appears on the display.



NOTICE

This fault message is only shown for a short time immediately following the Pre-Ride-Check.◀

Possible cause:

The anti-theft alarm system battery is completely discharged. Operation of the anti-theft alarm system is no longer ensured when the motorcycle's battery is disconnected.

- Contact an authorized service facility, preferably an authorized BMW Motorrad retailer.

Central locking locked

– with central locking system^{OE}



The locked symbol appears on the display.

All locks in the central locking system are locked.

ABS self-diagnosis not completed



The ABS indicator and warning light flashes.

Possible cause:

The self-diagnosis routine was not completed; the ABS function is not available. The motorcycle must be ridden at a speed of at least 3.1 mph (5 km/h) so that the ABS self-diagnosis can be completed.

- Ride off slowly. It must be noted that the ABS function is not available until the self-diagnosis has been completed.

ABS error



The ABS indicator and warning light light up.

Possible cause:

The ABS control unit has detected an error. The ABS function is not available.

- Continued driving is possible while taking the failed ABS function into account. Observe additional information on situations which can lead to an ABS error (→ 109).
- Have the malfunction corrected as soon as possible at an authorized workshop, preferably an authorized BMW Motorrad retailer.

DTC intervention



The DTC indicator light flashes rapidly.

The DTC has detected instability at the rear wheel and has reduced the torque. The indica-

tor light flashes longer than the DTC intervention lasts. This feature continues to furnish the rider with visual feedback confirming that the system has initiated active closed-loop intervention even after the critical situation has passed.

DTC self-diagnosis not completed



The DTC indicator light flashes slowly.

Possible cause:

The self-diagnosis routine was not completed; the DTC function is not available. The engine must be running and the motorcycle must be moved at a speed of at least 3.1 mph (5 km/h) in order for DTC self-diagnosis to complete.

- Ride off slowly. It must be noted that the DTC function

is not available until the self-diagnosis has been completed.

DTC deactivated



The DTC indicator light lights up.

Possible cause:

The DTC system has been deactivated by the driver.

- Switch on DTC.

DTC error



The DTC indicator light lights up.

Possible cause:

The DTC control unit has detected an error. The DTC function is not available.

- It remains possible to continue riding. It must be noted that the DTC function is not available. Observe additional information on situations which can lead to a DTC error (➡ 112).

- Have the malfunction corrected as soon as possible at an authorized workshop, preferably an authorized BMW Motorrad retailer.

D-ESA fault



The general warning light lights up yellow.



The D-ESA fault symbol is displayed.

Possible cause:

The D-ESA control unit has detected a fault. Motorcycle damping is in this condition very firm and riding is rather uncomfortable - in particular on rough roads.

- Have the malfunction corrected as soon as possible at an authorized service facility, preferably an authorized BMW Motorrad Retailer.

Range



The range indicates the travel distance available with the remaining fuel. The average consumption employed to calculate the remaining travel range does not appear in the display and may vary from the indicated average consumption.

You must put at least five liters of fuel into the fuel tank for the new level to be registered correctly. If the sensor cannot register the new level the range display cannot be updated.

If the motorcycle is standing on its side stand, the motorcycle's inclined position will prevent the fuel level from being registered accurately. For this reason travel range is only calculated with the side stand retracted.

**NOTICE**

The determined range is an approximate reading. BMW Motorrad therefore recommends that you do not try to use the full range before refueling. ◀

Fuel down to reserve

Fuel reserve symbol lights up.

The fuel-level reading is displayed in yellow.

**WARNING****Rough engine running or switching off of the engine due to a fuel shortage**

Accident hazard, damage to catalytic converter

- Do not drive to the extent that the fuel tank is completely empty. ◀

Possible cause:

At the most, the fuel tank still contains the reserve fuel quantity.



Reserve fuel quantity

Approx. 1.1 gal (Approx. 4 l)

- Refueling (▶▶▶ 101).

Hill Start Control Pro active

Stop symbol is displayed.

Possible cause:

Hill Start Control Pro (▶▶▶ 117) was activated automatically or was activated by the driver.

- Turn off Hill Start Control Pro.
- Using Hill Start Control Pro (▶▶▶ 76).
- Turn off automatic Hill Start Control Pro.
- Turning automatic Hill Start Control Pro on and off (▶▶▶ 77).

Hill Start Control Pro is automatically deactivated

The general warning lamp flashes yellow.



Stop symbol flashes briefly.

Possible cause:

Hill Start Control Pro was deactivated automatically.

- Side stand was folded out.
 - » Hill Start Control Pro is deactivated when the side stand is folded out.
- Engine was stopped.
 - » Hill Start Control Pro is deactivated when the engine is stopped.
- The driver drove off with Hill Start Control Pro active.
- Using Hill Start Control Pro (▶▶▶ 76).

Hill Start Control Pro cannot be activated

 The general warning lamp flashes yellow.

 Stop symbol flashes briefly.

Possible cause:

Hill Start Control Pro cannot be activated.

- Fold in side stand.
- » Hill Start Control Pro only works when the side stand is folded in.
- Start engine.
- » Hill Start Control Pro only works when the engine is running.

Brake temperature too high

 The general warning light lights up yellow.

 The brake temperature symbol is displayed.

 **DANGER**

Driving with overheated brakes

Risk of accident due to brake failure

- Adapt driving style.
- Use the engine brake to avoid frequent braking.◀

 **WARNING**

Failure to observe maintenance intervals

Accident hazard

- Comply with the maintenance intervals applicable for the brakes.◀

Service display

 If a service is due, the service symbol and the service due date in place of the

odometer are shown for a short time after the Pre-Ride-Check.

 If the service is overdue the General warning light briefly shows yellow and the service symbol lights up continuously.



If the countdown to the next service is less than one month, service due date **1** is displayed.



If the motorcycle covers high annual mileages then shorter service intervals may be required. If the countdown distance to the early service is less than 621 miles (1000 km), countdown distance **2** is displayed.



NOTICE

If the service display appears more than a month before the service date, the current day's date must be reset in the instrument cluster. This situation can occur if the battery was disconnected. ◀

Service overdue



The service symbol is displayed.



The general warning light briefly shows yellow after the Pre-Ride-Check.

Possible cause:

The required service has not yet been performed.

- Have the service performed as soon as possible by a specialist workshop, preferably an authorized BMW Motorrad retailer.

Operation

Steering and ignition lock	50	Riding mode	73
Ignition.....	50	Cruise-control system	74
Ignition with Keyless Ride.....	51	Hill Start Control	76
Emergency on/off switch (kill switch).....	56	Central locking system.....	77
Reverser	56	Handle heat.	81
Lights.....	58	Seat heating	82
Hazard warning flashers.....	60	Seat	83
Turn indicators.....	61	Storage compartments	84
Multifunction display	62		
On-board computer.....	66		
Trip recorder.....	67		
Anti-theft alarm system (DWA).....	68		
Dynamic Traction Control (DTC)....	72		
Electronic chassis and suspension adjustment (D-ESA)	72		

Steering and ignition lock

Vehicle keys

You are provided with 2 ignition keys. Should you lose your keys, refer to the information regarding the electronic immobilizer (EWS) (► 51).

Ignition steering lock, fuel filler cap, storage compartment, seat lock and cases are all operated with the same vehicle key.

Locking handlebars



ATTENTION

Handlebars turned in wrong direction when motorcycle propped on side stand.

Component damage cause by tipping over

- On level ground, always turn the handlebars to the left to set the steering lock.

- Otherwise the angle of the ground determines whether the handlebars are set to the left or right. ◀
- Turn handlebars to left.

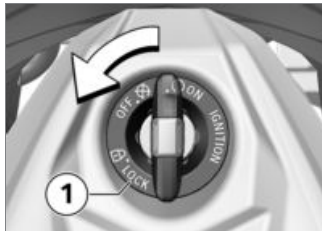

- Turn the ignition key to position **1** while moving the handlebars slightly.
 - » Ignition, lights and all electrical circuits switched off.
 - » Steering lock locked.
 - » Ignition key can now be removed.

Ignition

Switching on ignition

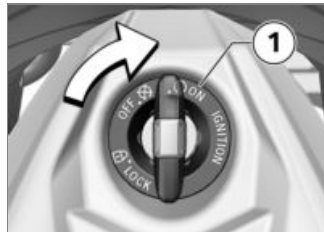

- Turn key to position **1**.
 - » Parking lights and all function circuits switched on.
 - » Engine can be started.
 - » Pre-Ride Check in progress. (► 95)
 - » ABS self-diagnosis is being performed. (► 95)
 - » DTC self-diagnosis is performed. (► 96)

Switch off ignition

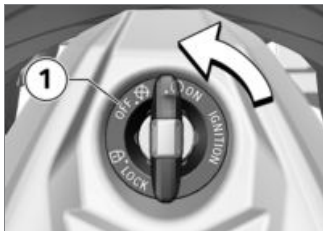

- Turn key to position **1**.
 - » Light switched off.
 - » Handlebars not locked.
 - » Ignition key can now be removed.
 - » The windshield automatically moves to the lower end position.

EWS Electronic immobilizer

The motorcycle's electronic circuitry monitors the data stored in the ignition key through a ring antenna incorporated in the igni-

tion lock. The engine management system does not enable engine starting until the vehicle key has been recognized as "authorized" for your motorcycle.

NOTICE

A further key attached to the same ring as the ignition key used to start the engine could "irritate" the electronics, in which case the enabling signal for starting is not issued. The warning is displayed in the multifunction display with the key symbol. Always store further vehicle keys separately from the ignition key. ◀

If you lose an ignition key, you can have it disabled by your BMW Motorrad partner. When having a key disabled you should also bring all of the motorcycle's remaining keys with you. The engine can no longer be started using a disabled vehicle

key; however, a disabled vehicle key can be enabled again. Emergency and spare keys are only available through an authorized BMW Motorrad retailer. The keys are part of an integrated security system, so the retailer is under an obligation to check the legitimacy of all applications for replacement/extra vehicle keys.

Ignition with Keyless Ride

Vehicle keys

– with Keyless Ride^{OE}

You are provided with one radio-operated key and one emergency key. Should you lose your keys, refer to the information regarding the electronic immobilizer (EWS) (➡ 51).

The ignition, tank filler cap, central locking system and anti-theft alarm system are controlled with

the radio-operated key. The seat lock, storage compartments and cases can be operated manually.



NOTICE

When the range of the radio key is exceeded (e.g. in the case), the motorcycle cannot be started and the central locking system cannot be locked/unlocked..

When the range is exceeded, the ignition is switched off after approx. 1.5 minutes, the central locking system is **not** locked. It is advisable to carry the radio-operated key directly on your person (e.g. in a jacket pocket) and to also carry the emergency key as an alternative. ◀



Range of Keyless Ride radio-operated key

Approx. 3.3 ft (Approx. 1 m)

Locking handlebars

– with Keyless Ride^{OE}

Requirement

Handlebars are turned to left or right.

Requirement

Radio-operated key is within reception range.



ATTENTION

Incorrect handlebar angle when parking on side stand

Component damage cause by tipping over

- On level ground, always turn the handlebars to the left to set the steering lock. ◀
- Press and hold button **1**.
 - » Steering lock audibly locks.
 - » Ignition, lights and all electrical circuits switched off.
- To unlock the steering lock, briefly press button **1**.

Switching on ignition

– with Keyless Ride^{OE}

Requirement

Radio-operated key is within reception range.

- The ignition can be activated in two ways:

Version 1



- Briefly press button **1**.
 - » Parking lights and all function circuits switched on.
 - » Engine can be started.
 - » Pre-Ride Check in progress. (▶▶▶ 95)
 - » ABS self-diagnosis is being performed. (▶▶▶ 95)
 - » DTC self-diagnosis is performed. (▶▶▶ 96)

Version 2

- Steering lock is locked, press and hold button **1**.
 - » Steering lock is unlocked.

- » Parking lights and all function circuits switched on.
- » Engine can be started.
- » Pre-Ride Check in progress. (▶▶▶ 95)
- » ABS self-diagnosis is being performed. (▶▶▶ 95)
- » DTC self-diagnosis is performed. (▶▶▶ 96)

Switch off ignition

– with Keyless Ride^{OE}

Requirement

Radio-operated key is within reception range.

- The ignition can be deactivated in two ways:

Version 1



- Briefly press button **1**.
 - » Light is switched off.
 - » Handlebars are not locked.
 - » The windshield automatically moves to the lower end position.

Version 2

- Turn handlebars to left.
- Press and hold button **1**.
 - » Light is switched off.
 - » Steering lock is locked.
 - » The windshield automatically moves to the lower end position.

EWS Electronic immobilizer

– with Keyless Ride^{OE}

The motorcycle's electronic circuitry monitors the data stored in the radio-operated key through a ring antenna incorporated in the radio lock. The engine management system does not enable engine starting until the radio-operated key has been recognized as "authorized" for your motorcycle.

NOTICE

A further key attached to the same ring as the ignition key used to start the engine could "irritate" the electronics, in which case the enabling signal for starting is not issued. The warning is displayed in the multifunction display with the key symbol. Always store further vehicle keys separately from the ignition key. ◀

If you lose a radio-operated key, you can have it disabled by your authorized BMW Motorrad retailer. When having a key disabled you should also bring all of the motorcycle's remaining keys with you.

The engine can no longer be started using a disabled radio-operated key; however, a disabled radio-operated key can be enabled again.

Emergency and spare keys are only available through an authorized BMW Motorrad retailer. As the radio-operated keys are part of an integrated security system, the retailer is under an obligation to check your legitimacy.

Battery of the key fob transmitter is empty or the key fob transmitter is lost

– with Keyless Ride^{OE}

NOTICE

The antenna is located in front of the tank filler cap or under the tank cover. ◀

- Should you lose your keys, refer to the information regarding the electronic immobilizer (EWS).
- Should you lose the radio-operated key during a trip, the vehicle can be started using the emergency key.
- If the battery of the key fob transmitter is flat, the vehicle can be started by touching the tank cover with the key fob transmitter.

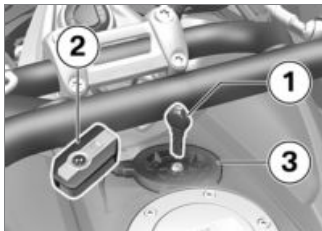

- Hold the emergency key **1** or the empty key fob transmitter **2** against the tank cover over the antenna **3**.



Period in which the engine must be started. Then unlocking must be repeated.

30 s

- » Pre-Ride-Check is carried out.
- Key has been detected.
- Engine can be started.
- Starting engine (→ 94).

Replacing the battery of the key fob transmitter

– with Keyless Ride^{OE}

If the key fob transmitter fails to react when the button is pressed briefly or is pressed and held:

- The battery of the key fob transmitter no longer has its full charging capacity.
- » Replace battery.



The battery symbol is displayed.

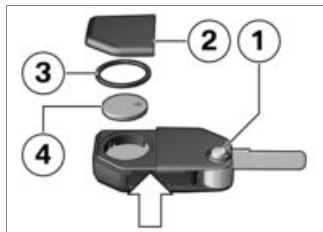

- Press button **1**.
- » Key bit folds open.

- Press battery cover **2** upward at recess for key bit.
- Remove battery cover **2** and seal **3**.
- Remove battery **4**.
- Dispose of the old battery in accordance with legal regulations. Do not dispose of the battery in the household waste.



ATTENTION

Unsuitable or improperly inserted batteries

Component damage

- Use a battery compliant with the manufacturer's specifications.
- When inserting the battery, make sure that the polarity is correct. ◀
- Insert the new battery with the positive terminal up.



Battery type

for Keyless Ride radio-operated key

CR 2032

- Install seal **3** and battery cover **2**.
- » Red LED in instrument panel flashes.
- » The remote-control is again ready to be used.

Emergency on/off switch (kill switch)



- 1** Emergency on/off switch (kill switch)



WARNING

Operation of the emergency ON/OFF switch when riding

Danger of falling due to blocking of rear wheel

- Do not operate the emergency ON/OFF switch when riding. ◀

The engine can be switched off easily and quickly using the emergency on/off switch.



- a** Engine is switched off
b Operating position

Reverser

– with reverser^{OE}

Requirements

The following prerequisites must be fulfilled to use the reverser:

- Motorcycle is standing.
- Engine is running.
- Transmission is in idle position.
- Side stand is retracted.
- Clutch is not pulled.

Reversing should be done without a passenger.

On downhill gradients, the reverser is not able to provide any holding function as is the case when a gear is engaged.

The reverser cannot be used on steep gradients.



Gradient for reverser

max 7 %

Activating reverser

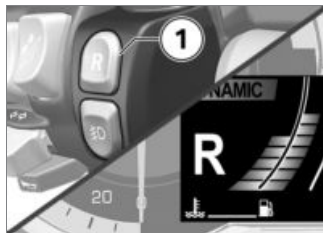

- Press button **1**.
 - » Gear indicator switches from "N" to "R".
 - » The reverser can be used as soon as the display "R" stops flashing.

Using reverser



- Press and hold starter button **1** to reverse.
 - » The engine speed is increased while reversing.
- Release the starter button **1** to finish reversing.



NOTICE

The motorcycle is not decelerated automatically after releasing the starter button and can therefore continue to roll. ◀

- » The engine speed lowers to idle speed again.

Automatic cancellation

Reversing is canceled automatically:

- if the gradient is too steep
- if there is an obstacle
- if the side stand is folded out
- if the brake is applied
- before the reversing motor overheats

"R" will flash in the display if reversing is canceled.

Deactivating reverser

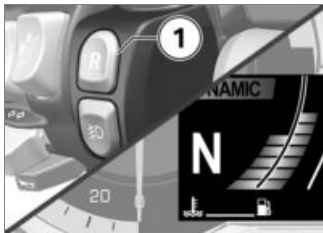

- Press button **1**.
- » Gear indicator switches from "R" to "N".

Lights

Parking lights

The parking lights come on automatically when the ignition is switched on.



The parking lights are a strain on the battery. Do not leave the ignition switched on longer than absolutely necessary.◀

Headlight low beam

The headlights automatically come on in their low-beam mode as soon as you start the engine.

High-beam headlight and headlight flasher



- Press switch **1** toward front to switch on high-beam headlight.
- Pull switch **1** toward rear to actuate headlight flasher.



The high-beam headlight can also be switched on when the engine is not running.◀

Parking lights

- Switch off ignition.

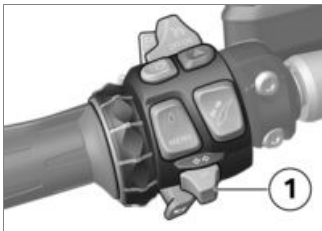

- Immediately after switching off ignition, push button **1** to left and hold it until parking lights come on.
- Switch ignition on and then off again to switch off parking light.

Setting right- or left-hand traffic

– with Adaptive Lights^{OE}

- Switch on the ignition.
- Call up the **Settings** menu and then select the **Vehicle** menu item.

- Select the **Headlight** menu item.



- **R-hand traffic:** for countries in which the traffic drives on the right-hand side of the road.
- **L-hand traffic:** for countries in which the traffic drives on the left-hand side of the road.

Headlight range

The xenon headlight has continuous beam throw control that keeps beam throw constant regardless of how the motorcycle is ridden and the load it carries.

Operating the auxiliary headlight

– with additional headlight^{OE}



NOTICE

The auxiliary headlights are approved for use as fog lights and may only be used in poor weather conditions. Comply with the country-specific road traffic regulations. ◀

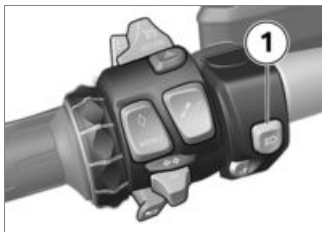

- Press button **1** to turn on the auxiliary headlight.



The telltale light shows.



If this warning symbol is displayed, the vehicle voltage is low. If applicable, the additional headlights might have been temporarily switched off.

- Press button **1** again to turn off the auxiliary headlight.

Operating the ground light

- with central locking system^{OE}
- with ground light^{OA}

Requirement

Ground light is allowed in your country.

- Switch on the ignition.
- Call up the **Settings** menu and then select the **Vehicle** menu item.
- Select the **Ground light** menu item.

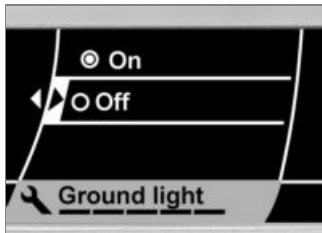

- **On**: ground light comes on for a brief period after the ignition is turned off.
 - **Off**: ground light does not come on after the ignition is turned off.
- » If the ground light was turned off as described above, it will still to be turned on by unlocking the central locking system.

Hazard warning flashers

Operating hazard warning flashers

- Switch on the ignition.



NOTICE

The hazard warning flashers place a strain on the battery. Do not use the hazard warning flashers for longer than absolutely necessary. ◀

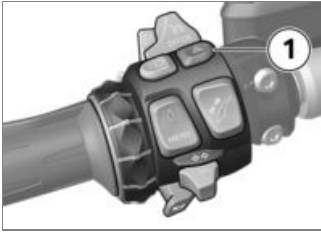

- Press button **1** to switch on hazard warning flashers.
» Ignition can be switched off.
To turn off the hazard warning lights system:
 - Turn on ignition and press button **1**.

Turn indicators

Operating turn signals

- Switch on the ignition.

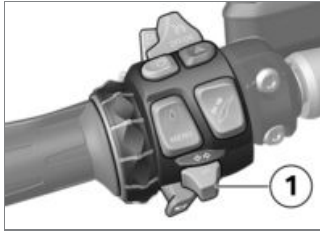

- Press button **1** to left to switch on left-side turn signals.
- Press button **1** to right to switch on right-side turn signals.
- Move button **1** to center position to switch off turn signals.

Comfort turn signals

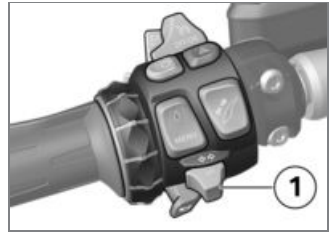

When button **1** is pressed to the right or left, the turn signal automatically turns off under the following conditions:

- Speed is under 18 mph (30 km/h): after traveling a distance of 165 ft (50 m).
- Speed is between 18 mph and 60 mph (30 km/h and 100 km/h): after covering a particular distance depending on the speed or when accelerating.

– Speed is above 60 mph (100 km/h): after turn signal flashes five times.

When button **1** is pressed and held slightly longer to the right or left, the turn signals will only turn off automatically after reaching the distance depending on the speed.

Multifunction display

Selecting a menu



The possible menus are called up using button **2**, starting with the *Information* menu. Pressing button **2** again will call up the

next menu; the number of menus depends on the vehicle equipment.

Direct access to a selectable menu is possible using button **3**.

Up to the *Audio* area, the *Settings* menu can only be called up when the vehicle is at a standstill.

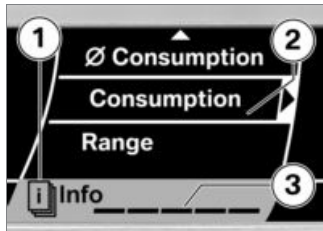

Position **1** shows the type of menu; cursor **2** shows the current selection. Each bar **3** represents a selectable menu. The bar of the current menu is hidden

to depict its position in the order of all menus.

NOTICE

A list of all the menus can be found in the separate Quick Reference Guide. ◀

Selecting a menu item

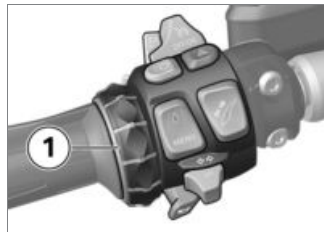

Use the Multi-Controller **1** to move the cursor within the menu.

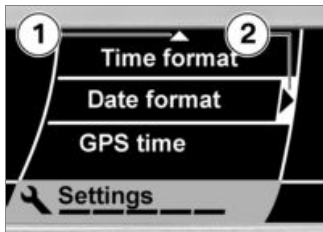

Making a setting



Direct selection:

If the cursor is placed on a menu item that does not require an additional setting, this selection will become active immediately.

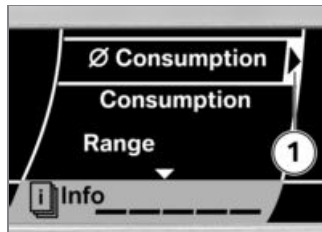

Reset values:

Average values that are indicated by an arrow **1** can be reset by a long press of the Multi-Controller to the right.

An arrow **1** at the upper or lower edge of the display indicates that additional menu items can be accessed by turning the Multi-Controller in the corresponding direction. If the arrow **2** is shown in the cursor, it indicates that a submenu can be called up by pressing the Multi-Controller to the right. For differing meanings of average values and the list selection, see (➡ 63).



Select from a list:

Selectable items in a selection list are indicated by a circle **2**. The current selection is indicated by a dot within the circle. To change the selection, select a list item using the cursor and then press the Multi-Controller to the right to activate or deactivate.

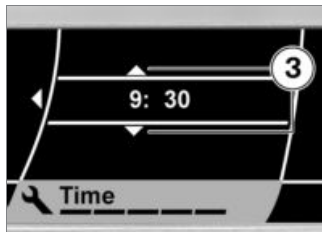

Set numerical value:

If there are multiple numerical values between the arrows **3**, these can be increased or decreased by turning the Multi-Controller upwards or downwards respectively. Switch between the values by pressing the Multi-Controller to the right or left.

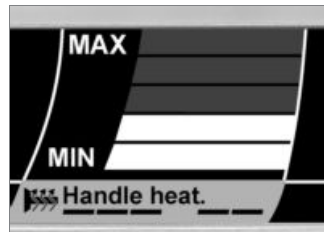

Set relative values:

Settings between two limit values are made using a bar display. The value to be set can be increased or decreased by turning the Multi-Controller upwards or downwards respectively.

Exiting the menu

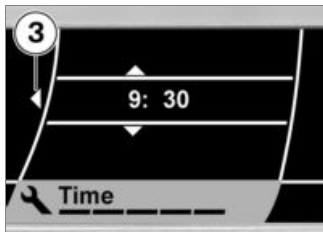

Arrow **3** is shown within sub-menus.

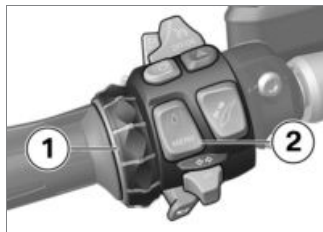

To jump back to the next-higher menu, press the Multi-Controller **1** to the left; to return to the main menu, press the **MENU** button **2**.

To hide the menus, the Multi-Controller **1** must be pressed to the left in a main menu.

Selecting the Favorite menu

- Select the desired main menu.



- Press and hold button **3**.
 The diamond appears to the right of the menu designation.

» The selected menu will be called up every time button **3** is subsequently pressed.

Adapting the display

- Switch on the ignition.
- Call up the **Settings** menu and select the **User** menu item.

The following settings are available:

- Language: display language (German, English, Spanish, Italian, French, Dutch, Portuguese)
- Time format - Clock format: clock in 12-hour format (12 h) or in 24-hour format (24 h)
- Time format - Date format: date in day.month.year format (dd.mm.yy) or in month/day/year format (mm/dd/yy)
- Time format - GPS time: accept GPS time and GPS date from built-in navigation system (On), (Off)
- Brightness: brightness of the display and the instruments
- Start logo: display start logo after the ignition is switched on (On), (Off)
- Background: shows on the display when the radio is turned off: Empty: no display, Logo: 6-cylinder logo, Speed ind.: digital speed indicator

- Default status: restore factory defaults (when Reset! appears on the display, press the Multi-Controller to the right and hold it in this position)
 - Make the desired settings using the Multi-Controller.

On-board computer

Selecting display readings

- Call up the Info menu and select the desired information.



The following information can be displayed in panel 3:

- Ø consumption: average fuel consumption
- Consumption: current fuel consumption
- Range: range with fuel remaining in fuel tank
- Ø speed: average speed
- Temperature: ambient temperature
- Tyre pressure: tire pressures
- Stopwatch: stopwatch
- Trav. times: travel times
- Date: current date
- Veh. voltage: vehicle voltage
- Oil level: engine oil level
- Off: no display

Resetting average data

- Call up the Information menu and then select the average value you want to reset.
- Press and hold the Multi-Controller to the right until the average value is reset.

Operating stopwatch

- Call up the **Info** menu and then select the **Stopwatch** menu item.



- With the stopwatch stopped, press the Multi-Controller **1** to the right to start the stopwatch.
 - » The time measurement will also continue to run if a different display is selected or the ignition is turned off.
- With the stopwatch running, press the Multi-Controller **1** to the right to stop the stopwatch.

- Press and hold the Multi-Controller **1** to the right to reset the stopwatch.

Measuring travel times

- Call up the **Info** menu and then select the **Trav. times** menu item.



- Press and hold the Multi-Controller **1** to the right to reset the travel time.
 - » The time measurement will also continue to run if a different display is selected or the ignition is turned off.

- ▶ Total driving time since the vehicle was last reset.

- || Immobilization period since the vehicle was last reset.

Trip recorder

Selecting the trip odometer

- Switch on the ignition.

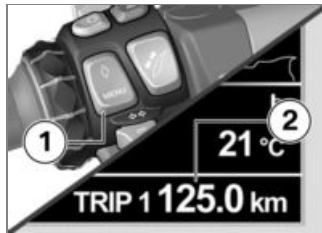

- Call up the **TRIP** menu by pressing button **1** and then select the desired trip distance recorder **2**.

The following odometers can be displayed:

- Trip odometer 1 (Trip 1)
- Trip odometer 2 (Trip 2)
- Automatic trip odometer (Trip Auto) resets automatically eight hours after the ignition is turned off.

Resetting the trip odometer

- Switch on the ignition.
- Select the desired trip odometer.



- Press and hold Multi-Controller **1** to the right until the

trip odometer **2** has been reset.

Anti-theft alarm system (DWA)

- with anti-theft alarm system (DWA)^{OE}

Activation without remote key or key fob transmitter

- If applicable, turn on the "Automatic activation of the anti-theft alarm after ignition OFF" function.
- Anti-theft alarm system settings (→ 71).
- Switch off ignition.
 - » Activation takes 30 seconds to complete.
 - » Turn indicators are illuminated twice.
 - » Confirmation tone sounds twice (if programmed).
 - » The anti-theft alarm system is active.

- To deactivate the movement sensor (for example if you are about to transport the motorcycle on a train and the swaying movement of the moving train could trip the alarm), call up the Settings menu before turning off the ignition.
- Select the **Vehicle - Sensor** menu item.

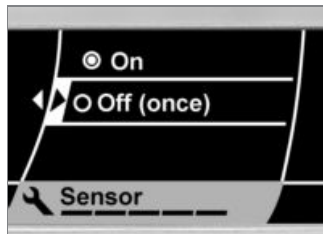

- Select **Off (once)** to turn off the movement sensor this one time.
- Switch off ignition.

- » Activation takes 30 seconds to complete.
- » Turn signals are illuminated three times.
- » Confirmation tone sounds three times (if programmed).
- » The anti-theft alarm system is active; the movement sensor is deactivated.

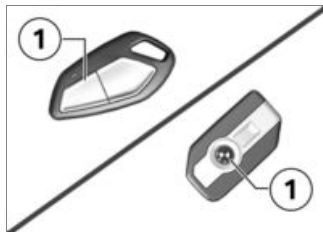

- Press button **1** on the remote key or radio-operated key twice.

NOTICE

See also the other functions of the remote control for the central locking system.◀

- » Activation takes 30 seconds to complete.
- » Turn indicators are illuminated twice.
- » Confirmation tone sounds twice (if programmed).
- » Alarm system is activated.

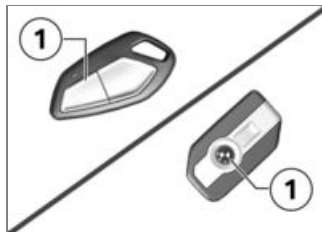

- To deactivate the motion sensor (for example if you are about to transport the motorcycle on a train and the swaying movement of the moving train could trip the alarm), press button **1** on the remote key or radio-operated key again during the activation phase.
- » Turn indicators are illuminated three times.
- » Confirmation tone sounds three times (if programmed).
- » Motion sensor is deactivated.

Activate with remote key or radio-operated key

NOTICE

Only motorcycles without Keyless Ride have a separate remote key for the central locking system and alarm system.◀

- Switch off ignition.

Alarm signal

The DWA alarm can be set off by:

- Motion sensor
- Switching on ignition with an unauthorized ignition key.
- Disconnecting the DWA from the motorcycle battery (DWA battery takes over the power supply – alarm sound only, hazard warning lights do not flash).

If the DWA battery is discharged all functions remain operational; the only difference is that the alarm cannot be set off if the system is disconnected from the motorcycle battery.

The duration of the alarm is approx. 26 seconds. During the alarm, an alarm tone sounds and the turn indicators flash. The type of alarm tone can be programmed in the multifunction display.

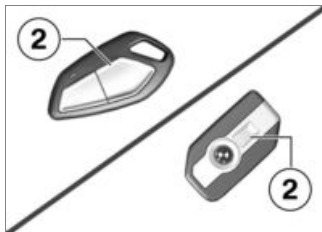

You can cancel an alarm at any time without deactivating the DWA by pressing button **2** on the remote key or key fob transmitter.

If an alarm was triggered while the motorcycle was unattended, the rider is notified accordingly by an alarm tone sounding once when the ignition is turned on. The DWA LED then signals the reason for the alarm for one minute.

Light signals on DWA LED:

- 1 flash: Motion sensor 1
- 2 flashes: Motion sensor 2
- 3 flashes: ignition turned on with unauthorized ignition key
- 4 flashes: alarm system disconnected from vehicle battery
- 5 flashes: motion sensor 3

Deactivate without remote key or radio-operated key

- Emergency on/off switch (kill switch) in normal operating position.
- Switch on the ignition.
 - » Turn indicators light up once.
 - » Confirmation tone sounds once (if programmed).
 - » Alarm system is deactivated.

Deactivate with remote key or radio-operated key

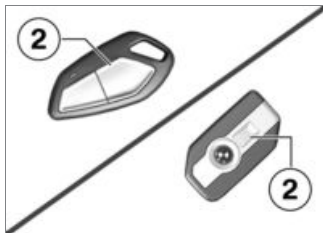

- Press button **2** on the remote key or radio-operated key once.

NOTICE

See also the other functions of the remote control for the central locking system.◀

NOTICE

If the alarm function is deactivated using the radio-operated key and the ignition is not then switched on, it will reactivate au-

tomatically after 30 seconds if "activation after ignition off" is programmed.◀

- » Turn indicators light up once.
- » Confirmation tone sounds once (if programmed).
- » Alarm system is deactivated.

Anti-theft alarm system settings

- Call up the **Settings** menu and select the **Vehicle - Alarm system** menu item.

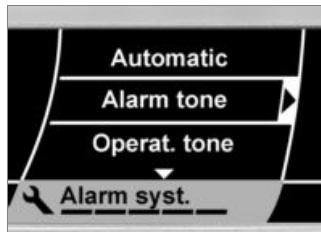

The following settings are available:

- **Automatic mode - On:** anti-theft alarm system is activated automatically after the ignition is turned off.
- **Automatic mode - Off:** anti-theft alarm system must be activated with the remote key after the ignition is turned off.
- **Alarm tone:** type of alarm tone.
- **Key sound - On:** turn signals flash and one tone sounds as confirmation when the anti-theft alarm system is turned on or off.
- **Key sound - Off:** only the turn signals flash as confirmation when anti-theft alarm system is turned on or off.
- Make the desired setting using the Multi-Controller.

Dynamic Traction Control (DTC)

Turning the DTC function off and on

- Switch on the ignition.
- Call up the **Settings** menu and then select the **DTC** menu item.

NOTICE

This menu cannot be called up while the motorcycle is on the move. ◀



- Select **Off (once)** to turn off the DTC one time until the next time the ignition is turned on.



The DTC indicator light will light up if the DTC is turned off.

- Select **On** to turn on the DTC. Alternative: turn the ignition off and on again.



The DTC indicator light goes out, if self-diagnosis has not been completed, the DTC indicator light begins to flash.

Electronic chassis and suspension adjustment (D-ESA)

Setting suspension compliance

- Start engine.



The damping is displayed in the multifunction display in area **1**, and spring preload is indicated in area **2**.

- Call up the **Dynamic ESA** menu.

NOTICE

The damping cannot be adjusted while the motorcycle is being ridden. ◀

The range of adjustment for damping is shown.

- **ROAD**: Normal damping
- **CRUISE**: Comfortable damping

- Select the desired damping or move the cursor upwards to adjust the load.

NOTICE

The load setting cannot be adjusted while the motorcycle is underway.◀

The range of adjustment for spring preload is shown.



One-up



One-up with luggage



Two-up (with luggage)

- Select desired load variant.
 - » The chassis and suspension are set according to the selection and the Dynamic ESA display is adapted to the new setting. The symbols for loading and damping are shown

in gray during the adjustment procedure.

Riding mode

Setting riding mode

- Switch on the ignition.



- Press button 1.

NOTICE

Details on the selectable driving modes are provided in the chapter "Technology in Detail".◀



The current setting is shown at position 2; each time the button is pressed one of the possible riding modes is shown at position 3.

- Press button repeatedly until desired riding mode is shown.
 - » If the motorcycle is stopped, the selected riding mode is activated after a short time.
 - » The new riding mode is activated during operation under the following conditions:
 - Brakes not engaged
 - Throttle grip turned back completely

- Riding modes can also be activated by actuating the clutch.
- » After the new riding mode is activated, the selection display disappears.
- » The riding mode selected and its associated engine-characteristics and DTC adaptations are retained even after the ignition has been turned off.

Cruise-control system

Turning cruise control on



- Push switch **1** to right.
- » Button **2** is operable.

Store speed



- Briefly press button **2** forward.



NOTICE

The cruise control can be set within a speed range from 19 mph (30 km/h) to 124 mph (200 km/h). ◀



SET Indicator light for cruise-control system lights up.

- » The motorcycle maintains your current cruising speed and the setting is saved.

Accelerating



- Briefly press button **2** forward.
- » Speed is increased by 0.6 mph (1 km/h) each time the button is pressed.
- Press button **2** forward and hold.
- » The motorcycle accelerates steplessly.
- » If the button **2** is no longer pressed, the speed achieved is maintained and saved.

Decreasing speed



- Briefly press button **2** backward.
 - » Speed is reduced by 0.6 mph (1 km/h) each time the button is pressed.
- Press button **2** back and hold.
 - » The motorcycle decelerates steplessly.
 - » If the button **2** is no longer pressed, the speed achieved is maintained and saved.

Deactivate cruise control

- Actuate brakes, clutch or throttle grip (take back throttle be-

yond back position) to deactivate cruise-control system.

- » Cruise control indicator lamp goes out.

Resuming former cruising speed



- Briefly push button **2** back to return to the speed saved beforehand.

NOTICE

Opening the throttle does not deactivate the cruise-control system. If you release the throttle grip, the motorcycle will decel-

erate only to the cruising speed saved in memory, even though you might have intended slowing to a lower speed.◀

SET Indicator light for cruise-control system lights up.

Turning cruise control off



- Push switch **1** to left.
 - » The system is deactivated.
 - » Button **2** is locked.

Hill Start Control Using Hill Start Control Pro

ATTENTION

Drive-off assistant failure

Accident hazard

- Manually brake to secure the vehicle. ◀

NOTICE

Hill Start Control is only a convenience system for easier hill-starting and should, therefore, not be confused with a parking brake. ◀

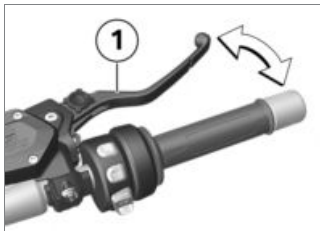

- Apply brake lever **1** firmly and then release.

 Green Hill Start Control indicator light appears on the display.

- » Hill Start Control Pro is now activated.
- To turn off Hill Start Control Pro, pull brake lever **1** again.

NOTICE

If Hill Start Control Pro is deactivated using the brake lever, auto-

matic Hill Start Control is deactivated for the next 4 m. ◀

- Alternatively, drive off in 1st or 2nd gear.

NOTICE

Hill Start Control Pro is deactivated automatically when driving off. ◀

 When automatic Hill Start Control Pro is turned off, the stop symbol disappears after the brake has been released completely. When automatic Hill Start Control Pro is turned on, the white stop symbol appears.

- » Hill Start Control Pro is now deactivated.
- More information about Hill Start Control Pro can be found in the section "Technology in detail":
- » Hill Start Control function (▮▶ 117)

Turning automatic Hill Start Control Pro on and off

- Switch on the ignition.
- Call up the **Settings** menu and then select the **HSC AUTO** menu item.



- To turn on automatic Hill Start Control Pro, select **On**.

 White Hill Start Control indicator light appears on the display.

- » When applying the brake for approximately one second after the vehicle has come to a

standstill and on a slope with at least a 5% gradient, Hill Start Control Pro is activated automatically.

- To turn off automatic Hill Start Control Pro, select **Off**.
 - » The selected setting is retained even after the ignition is turned off.

Central locking system Locking

– with central locking system^{OE}



- Turn on ignition and press button **3**.

NOTICE

Only motorcycles without Keyless Ride have a separate remote key for the central locking system and alarm system.◀

- Alternative: press button **1** on the remote key.
 - » The storage compartments in the side trim panels and the cases are locked.
 - » The locks can no longer be unlocked manually.

 The locked symbol appears on the display.

– with anti-theft alarm system (DWA)^{OE}

- » The functions of the remote key for the anti-theft alarm system are described in the corresponding chapter.<

Unlocking

– with central locking system^{OE}



- Turn on ignition and press button **3**.
 - Alternative: press button **2** on the remote key.
 - » The storage compartments in the side trim panels and the cases are unlocked.
 - » Locks that were already locked manually must also be unlocked again manually.
- with anti-theft alarm system (DWA)^{OE}
- » The functions of the remote key for the anti-theft alarm sys-

tem are described in the corresponding chapter.◁

– with ground light^{OA}

- » The ground light will be turned on briefly if the remote key is used to unlock the vehicle with the ignition turned off.◁

Emergency release

– with central locking system^{OE}

If the central locking system can no longer be opened, you can open the cases and storage compartments manually as follows:

- Open case (▮▮▮ 151).

– with storage compartment^{OE}



- Turn the key in the storage compartment lock to the intermediate position between LOCK and the position of the dot.
- Press in lock barrel.
 - » Storage compartment flap pops up.

Logon of remote keys

– with central locking system^{OE}

– with anti-theft alarm system (DWA)^{OE}

– without Keyless Ride^{OE}

If a remote key has been mislaid and a replacement acquired or if you are going to use an additional remote key, you must invariably log on all the remote keys in the set.

- Enable logon of the remote keys as follows:
- Switch on the ignition.

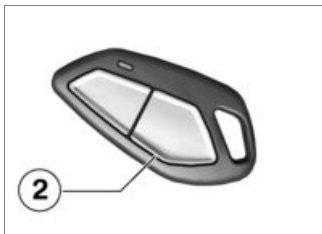

- Press button **2** on the remote key three times.
 - » One acoustic signal sounds.
- Turn off the ignition within ten seconds.

- Press button **2** on the remote key three times.
 - » One acoustic signal sounds.
- Turn on the ignition within ten seconds.

You can now proceed to log on all the remote keys.

- Step through the following procedure with each remote key in turn:

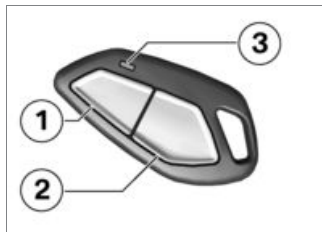

- Press and hold down buttons **1** and **2** until LED **3** stops flashing.
 - » LED **3** flashes for about ten seconds.

- Release buttons **1** and **2**.
 - » LED **3** is illuminated.
 - Actuate the **1** button or **2** button.
 - » One acoustic signal sounds and LED **3** goes out.
- To complete logon:
- Turn off ignition.
 - » Three acoustic signals are issued.
 - » Logon is also ended
 - when four remote keys have been logged on.
 - if you have logged on the first remote key and then do not press a button within approximately 30 seconds.

Synchronizing the remote-control units

- with central locking system^{OE}
- with anti-theft alarm system (DWA)^{OE}
- without Keyless Ride^{OE}

If the central locking system stops responding to the signals from a remote control unit then the unit will need to be resynchronized. This scenario can arise (for example) after the remote-control unit's buttons have been pressed frequently while the unit was beyond the range of the alarm system.

- The procedure for synchronizing the remote controls is as follows:
- Switch on the ignition.

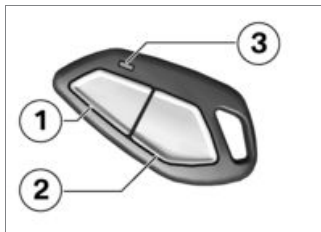

- Press and hold down buttons **1** and **2** until LED **3** stops flashing.
 - » LED **3** flashes for about ten seconds.
- Release buttons **1** and **2**.
 - » LED **3** is illuminated.
- Press button **1** or button **2**.
 - » LED **3** goes out.

Replacing battery in the remote-control unit

- with central locking system^{OE}
- with anti-theft alarm system (DWA)^{OE}
- without Keyless Ride^{OE}

If the LED lamp on the remote-control unit fails to light up when a button is pressed, or only lights up briefly:

- Replace the battery in the remote-control unit.

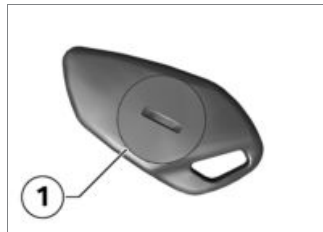

- Open lid of battery compartment **1**.
- Dispose of the old battery in accordance with legal regulations. Do not dispose of the battery in the household waste.

ATTENTION

Unsuitable or improperly inserted batteries

Component damage

- Use a battery compliant with the manufacturer's specifications.
- When inserting the battery, make sure that the polarity is correct.◀
- Insert the new battery with the positive side up.

 Battery type and battery voltage

for remote key

CR 2032

- » The LED on the remote control lights up; the remote control has to be synchronized.

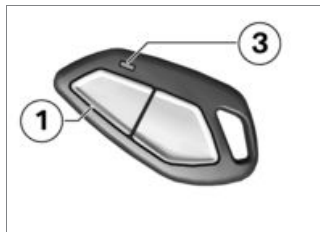

- Press button **1** twice.
 - » LED **3** flashes for a few seconds.
 - » The remote-control is again ready to be used.

Handle heat.

Operating the grip heating

- Start engine.

NOTICE

The heated grips option can only be activated when the engine is running.◀

- Call up the `Handle heat.` menu.

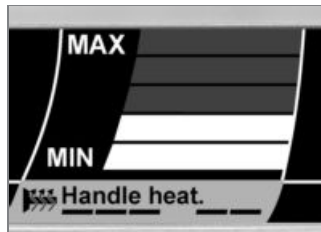

The grips have five-stage heating. Stage five is for heating the grips quickly. It is advisable to switch back to a lower stage as soon as the grips are warm.

- Select the desired heating stage.



Symbol **1** appears on the display indicating that the grip heating is turned on.



If this warning symbol is displayed, the vehicle voltage is low. If applicable, the handlebar grip heating might have been temporarily switched off.

Seat heating

Rider's seat heating

- Start engine.



NOTICE

Seat heating can be activated only when the engine is running.◀

- Call up the Seat heating menu.



The rider's seat has five-stage heating. Stage five is for heating the seat quickly: it is advisable to switch back to a lower stage as soon as the seat is warm.

- Select the desired heating stage.



Symbol **1** appears on the display, indicating that the seat heating is ON.



If this warning symbol is displayed, the vehicle voltage is low. If applicable, the seat heating might have been temporarily switched off.

Passenger seat heating

- Start engine.



NOTICE

Seat heating can be activated only when the engine is running.◀



- Select desired heating level with switch **1**.

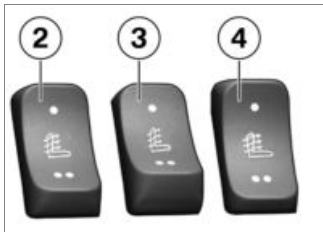

The passenger seat has two-stage heating. The second stage is used for heating the seat quickly. It is advisable to switch

back to the first stage as soon as the seat is warm.

- **2** Switch in middle position: Heating off.
- **3** Switch in one-dot position: 50 % heating output.
- **4** Switch in two-dot position: 100 % heating output.



Symbol **1** appears on the display, indicating that the rear seat heating is ON.



If this warning symbol is displayed, the vehicle voltage is low. If applicable, the seat

heating might have been temporarily switched off.

Seat

Removing seat



- Open left case.
- Actuate unlocking mechanism **1** and raise seat at rear.

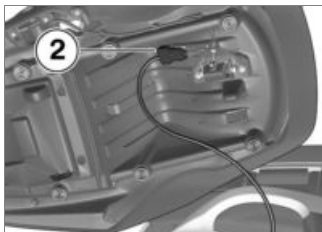

- Disconnect plug **2** of the seat heating and remove the seat.
- Place the seat, upholstered side down, on a clean surface.

Install seat

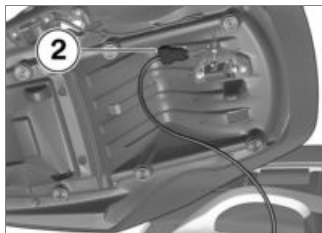

- Connect plug connection **2** of the seat heating.

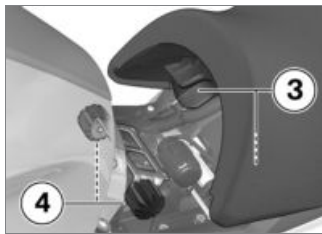

- Position the seat with mounts **3** in rubber buffers **4** on left and right.

- Lower the rear of the seat and engage the seat in the latching mechanism.

Storage compartments

– with storage compartment^{OE}

Operating the storage compartment

– with central locking system^{OE}

- Open the central locking system, if necessary.◁

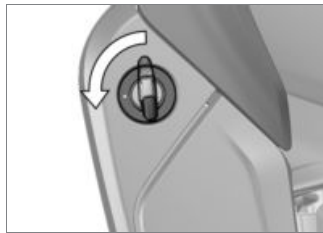

- Turn key in the storage compartment lock to the position indicated by the dot.

- Press the unlocked lock barrel to open the flap.
- The description applies analogously to the storage compartment on the right side.



ATTENTION

High temperatures in storage compartments

Damage to stored items or devices

- Refer to the device operating instructions for possible usage restrictions.◀
- Do not place objects that are sensitive to heat in the storage compartment during the summer.

Setting

Mirrors	88
Windshield	88
Wind deflection wing.....	89
Clutch	89
Brakes	90

Mirrors

Adjusting mirrors



- Move mirror into desired position by pressing it lightly.

Windshield

Adjusting the windshield

- Switch on the ignition.
- » When driving off, the windshield automatically moves to its last position before the ignition was turned off.



- Press button **1** at the top to raise the windshield.



NOTICE

The button symbol may be different from the figure shown. ◀

- Press button **1** at the bottom to lower the windshield.
- Turn off ignition.
- » The windshield automatically moves to the lower end position.
- » If the windshield encounters resistance before reaching the end position, the pressure-sensitive finger guard system

activates. The windshield is stopped and moves upwards slightly. After several seconds, the windshield will attempt to move to the end position again.

The proper functioning of the pressure-sensitive finger guard system cannot be ensured if a windshield that has not been approved by BMW Motorrad has been installed.

- In this case: Ensure the clearance of the windshield before switching off the ignition.

Wind deflection wing

Adjusting the wind deflection wing



WARNING

Adjusting the slipstream deflectors.

Accident hazard

- Only adjust the slipstream deflectors when the motorcycle is stationary.◀
- Turn the wind deflection wing **1** inwards or outwards to adjust the wind flow for the

rider. While doing so, observe the outer stop.

Clutch

Adjusting clutch lever

WARNING

Modified position of the clutch fluid reservoir

Air in the clutch system

- Do not turn the handlebar fitting on the handlebar.◀

WARNING

Adjusting the clutch lever while driving

Accident hazard

- Adjust the clutch lever when the motorcycle is stationary.◀

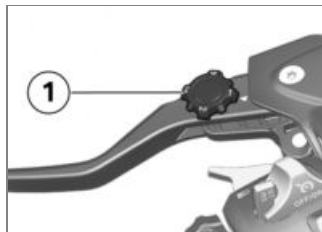

- Turn adjusting wheel **1** into desired position.

NOTICE

The adjustment wheel can be turned more easily if you press the clutch lever forward when doing so.◀

- » Four settings are available:
 - Position 1: smallest distance between handlebar grip and clutch lever.
 - Position 4: largest distance between handlebar grip and clutch lever.

Brakes

Adjust brake lever

WARNING

Modified position of the brake fluid reservoir

Air in the brake system

- Do not turn the handlebar fitting on the handlebar. ◀

WARNING

Adjusting the brake lever while driving

Accident hazard

- Only adjust the brake lever when the motorcycle is stationary. ◀

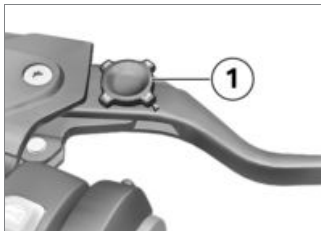

- Turn adjusting wheel **1** into desired position.

NOTICE

The adjustment wheel can be turned more easily if you press the handbrake lever forward when doing so. ◀

- » Four settings are available:
 - Position 1: smallest distance between handlebar grip and brake lever.
 - Position 4: largest distance between handlebar grip and brake lever.

Riding

Safety information	92
Observe checklist.....	94
Always before riding off	94
At every third refueling stop.....	94
Starting	94
Breaking in.....	97
Brakes	98
Parking your motorcycle	100
Refueling	100
Securing motorcycle for trans- port	104

Safety information

Rider's Equipment

Do not ride without the correct clothing. Always wear:

- Helmet
- Rider's suit
- Gloves
- Boots

This applies even to short journeys, and to every season of the year. Your authorized BMW Motorrad retailer will be happy to advise you and has the correct clothing for every purpose.



ATTENTION

Use of materials that leave a stain (e.g., blue jeans) on the seat

Discoloration of the seat

- Avoid contact with materials that leave a stain.◀

Correct loading



WARNING

Reduced riding stability caused by overloading and uneven loading

Accident hazard

- Do not exceed the gross weight limit and observe the loading information.◀
- Adjust spring preload, suspension damping rate settings and tire inflation pressures for the current gross motorcycle weight.
- Make sure that weight is uniformly distributed between right and left.
- Pack heavy pieces of luggage and cargo as low and as close to the center of the motorcycle as possible.
- Observe maximum payload and maximum speed as indicated on label in case.

Speed

If you ride at high speed, always bear in mind that various boundary conditions can adversely affect the handling of your motorcycle:

- Incorrect settings of spring-strut and shock absorber system
 - Imbalanced load
 - Loose clothing
 - Insufficient tire inflation pressure
 - Poor tire tread
 - Etc.
- with running board^{OE}

Riding with running boards

There is not a footbrake lever on the running board!

Please see the "Technology in detail" (▶▶▶ 108) chapter for more information about the partially integral brake.



NOTICE

As it is only possible to brake at the brake lever, observe the maximum speed for trips with running boards:◀



Top speed

– with running board^{OE}

max 112 mph (max 180 km/h)
(Maximum speed when riding with running boards)◀

Risk of poisoning

Exhaust fumes contain carbon monoxide, which is colorless and odorless but highly toxic.



WARNING

Harmful exhaust gas

Danger of suffocation

- Do not inhale exhaust fumes.

- Do not run the engine in closed rooms.◀

Burn hazard



CAUTION

Intense heating up of engine and exhaust system while riding

Burn hazard

- After parking the motorcycle, make sure that no persons or objects come into contact with the engine and exhaust system.◀

Catalytic converter

There is a danger of overheating and damage if misfiring causes unburned fuel to enter the catalytic converter.

For this reason, observe the following points:

- Do not run the fuel tank dry.
- Do not run the engine with the spark-plug cap removed.
- Stop the engine immediately if it misfires.
- Use unleaded fuel only.
- Comply with all specified maintenance intervals.



ATTENTION

Unburned fuel in the catalytic converter

Damage to catalytic converter

- Note the points listed for protection of the catalytic converter.◀

Danger of overheating



ATTENTION

Engine idling for a lengthy period while at a standstill

Overheating due to insufficient cooling; in extreme cases vehicle fire

- Do not allow the engine to idle unnecessarily.
- After starting, ride off immediately. ◀

Manipulation



ATTENTION

Modifications to the motorcycle (e.g. engine control unit, throttle valves, clutch)

Damage to the affected parts, failure of safety-relevant functions, expiration of warranty

- Do not make any modifications. ◀

Observe checklist

- Use the following checklist to check your motorcycle at regular intervals.

Always before riding off

- Check operation of the brake system.
- Check operation of the lighting and signal system.
- Check clutch function (▶▶▶▶ 127).
- Checking tire tread depth (▶▶▶▶ 129).
- Check secure hold of cases and luggage.

At every third refueling stop

- Check engine oil level (▶▶▶▶ 122).
- Check front brake pad thickness (▶▶▶▶ 124).
- Check rear brake pad thickness (▶▶▶▶ 124).
- Checking front brake fluid level (▶▶▶▶ 125).
- Checking rear brake fluid level (▶▶▶▶ 126).
- Check coolant level (▶▶▶▶ 127).

Starting

Starting engine

- Switch on the ignition.
 - » Pre-Ride Check in progress. (▶▶▶▶ 95)
 - » ABS self-diagnosis is being performed. (▶▶▶▶ 95)
 - » DTC self-diagnosis is performed. (▶▶▶▶ 96)
- Engage neutral, or pull back clutch lever if a gear is engaged.



NOTICE

You cannot start the motorcycle with the side stand extended and a gear engaged. The engine will switch itself off if it is started with the transmission in neutral and then a gear is engaged before retracting the side stand. ◀

- For cold starts and at low ambient temperatures: pull lever

to disengage clutch and twist throttle grip slightly.



- Press starter button 1.

NOTICE

The starting attempt is automatically interrupted if battery voltage is too low. Recharge the battery before you attempt to start the engine again, or use jumper cables and a donor battery to start. More detailed information can be found in the "Maintenance" chapter under "Jump-starting". ◀

» Engine starts.

» Consult the troubleshooting chart if the engine refuses to start. (▶▶▶ 162)

Pre-Ride Check

After the ignition has been turned on, the instrument panel performs a test of the indicator and warning lights of the ABS, the ASC, the universal warning light and the indicators. The logo is shown in the display during this.

Phase 1



The ABS indicator and warning light light up.



The general warning light lights up yellow.

Phase 2



The ABS indicator and warning light light up.



The general warning light lights up red.

If the universal warning light fails to appear in the display:



WARNING

Faulty general warning light.

Lack of display of malfunctions.

- Check that the 'General' warning light comes on, and that it shows red and yellow. ◀
- Have the malfunction corrected as soon as possible at an authorized service facility, preferably an authorized BMW Motorrad Retailer.

ABS self-diagnosis

The self-diagnosis routine checks whether the BMW Motorrad Integral ABS is ready for operation. The self-diagnosis routine launches automatically when you switch on the ignition.

Phase 1

- » Check on system components monitored by diagnostic system while motorcycle is parked.



The ABS indicator and warning light flashes.

Phase 2

- » Check wheel sensors while starting off. The motorcycle must be ridden at a speed of at least 3 mph (5 km/h) so that the ABS self-diagnosis can be completed.



The ABS indicator and warning light flashes.

ABS self-diagnosis completed

- » The ABS indicator and warning light goes out.

If an ABS error is displayed after the ABS self-diagnosis is completed:

- It remains possible to continue riding. Please be aware that neither the ABS function nor the integral function is available.
- Have the malfunction corrected as soon as possible at an authorized service facility, preferably an authorized BMW Motorrad Retailer.

DTC self-diagnosis

The self-diagnosis routine is determining whether BMW Motorrad DTC is ready for operation. The self-diagnosis routine runs automatically when you switch on the ignition.

Phase 1

- » Check on system components monitored by diagnostic system while motorcycle is parked.



The DTC indicator light flashes slowly.

Phase 2

- » Checking the diagnosable system components while driving. The engine must be running and the motorcycle must be moving at a speed of at least 3 mph (5 km/h) in order for the DTC self-diagnosis to complete.



The DTC indicator light flashes slowly.

DTC self-diagnosis completed

- » The DTC symbol is no longer displayed.

If an DTC error is displayed after the DTC self-diagnosis is completed:

- It remains possible to continue riding. It must be noted that the DTC function is not available.
- Have the malfunction corrected as soon as possible at an

authorized service facility, preferably an authorized BMW Motorrad Retailer.

Breaking in Engine

- While running in the motorcycle, vary the throttle opening and engine-speed range frequently; avoid driving for long periods at a constant speed.
- Try to do most of your riding during this initial period on twisting, fairly hilly roads, avoiding highways if possible.
- Observe the engine run-in speeds.



Engine run-in speed

<5000 min⁻¹ (Mileage 0...186 miles (0...300 km))

<6500 min⁻¹ (Mileage 186...621 miles (300...1000 km))



Engine run-in speed

no full throttle (Mileage 0...621 miles (0...1000 km))

- Have the first break-in service performed after 300 – 750 mls (500 - 1200 km).

Brake pads

New brake pads must be run in before they achieve their optimum friction force. This initial reduction in braking efficiency can be compensated for by exerting greater pressure on the brake levers.



WARNING

New brake pads

Extension of the braking distance, accident hazard

- Brake early.◀

Tires

New tires have a smooth surface. This must be roughened by riding in a restrained manner at various heel angles until the tires are run in. This running in procedure is essential if the tires are to achieve maximum grip.



WARNING

Loss of adhesion of new tires on wet roads and at extreme angles

Accident hazard

- Always think well ahead and avoid extreme angles.◀

Brakes

How do you achieve the shortest stopping distances?

The dynamic load distribution between the front and rear wheel changes during braking. The heavier you brake, the greater the weight transfer to the front wheel. Increases in the load on an individual wheel are accompanied by a rise in the effective braking force that the wheel can provide.

To achieve the shortest possible braking distance, the front brake must be applied quickly and with progressively greater levels of force. This procedure provides ideal exploitation of the extra weight transfer to the front wheel. The clutch should also be disengaged at the same time. With the frequently instructed "forced braking," in which the

brake pressure is generated as quickly as possible and with great force, dynamic load distribution lags behind the progressive increases in deceleration rate and the braking force cannot be completely transferred to the road surface.

BMW Motorrad Integral ABS prevents the front wheel from locking.

Brake force display

If the rider brakes heavily, the turn signal lamps are turned on in addition to the brake light in order to warn road users behind with a larger display area.

Descending mountain passes



Braking only with the rear-wheel brake when descending mountain passes.

Loss of braking action. Destruction of the brakes caused by overheating.

- Apply the front wheel brake and use the engine brake.◀



Driving with overheated brakes

Risk of accident due to brake failure

- Adapt driving style.
- Use the engine brake to avoid frequent braking.◀



Failure to observe maintenance intervals

Accident hazard

- Comply with the maintenance intervals applicable for the brakes.◀

Wet, soiled brakes

Moisture and dirt on the brake disks and the brake pads result in a decrease in the braking action. Delayed or poorer braking action must be expected in the following situations:

- When driving in the rain and through puddles.
- After washing the motorcycle.
- When driving on roads spread with salt.
- After working on the brakes due to oil or grease residues.
- When driving on soiled roads or offroad.

WARNING

Poorer braking action due to moisture and dirt

Accident hazard

- Brake until brakes are dry or clean; clean if necessary.

- Brake early until the full braking action is available again.◀

ABS Pro

Physical riding limits

WARNING

Braking in curves

Danger of falling despite ABS Pro

- The rider is always responsible for adapting his/her driving style.
- Do not reduce the system's extra safety margin with careless riding or unnecessary risks.◀

ABS Pro is available in all riding modes.

Falling cannot be excluded

Although ABS Pro represents valuable support and an enormous safety advantage for the rider when braking in the inclined position, it by no means redefines the physical riding limits. It

is still possible to exceed those limits through misjudgments or riding errors. In extreme cases this may result in a fall.

Use on public roads

ABS Pro helps make riding your motorcycle on public roads even safer. When braking due to unexpected hazards in curves, locking-up and slipping of the wheels is prevented within the scope of the physical riding limits.

NOTICE

ABS Pro was not developed to increase the individual braking performance in the inclined position.◀

Parking your motorcycle

Side stand

- Switch off engine.



ATTENTION

Poor ground conditions in area of stand

Component damage cause by tipping over

- Always check that the ground under the stand is level and firm.◀
- Fold out side stand and park motorcycle.



ATTENTION

Loading of the side stand with additional weight

Component damage cause by tipping over

- Do not sit on the motorcycle when it is parked on the side stands.◀

- If the slope of the road permits, turn the handlebars to the left.
- On a grade, the motorcycle should always face uphill; select 1st gear.

Center stand

– with center stand^{OE}

- Switch off engine.



ATTENTION

Poor ground conditions in area of stand

Component damage cause by tipping over

- Always check that the ground under the stand is level and firm.◀



ATTENTION

Center stand folds if subject to sharp movements.

Component damage cause by tipping over

- Do not sit on the motorcycle while it is resting on the center stand.◀
- Fold out center stand and jack up motorcycle.

Refueling

Fuel specifications

Requirement

For optimal fuel economy, the gasoline should be sulfur-free or very low in sulfur content.



ATTENTION

Refueling with leaded fuel

Damage to catalytic converter

- Do not refuel with leaded gasoline or gasoline with metallic additives, e.g. manganese or iron.◀



ATTENTION

Use of Ethanol E85 as fuel

Damage to the engine and fuel supply

- Do not refuel with E85, i.e. fuel with an ethanol content of 85 %, or with Flex Fuel.◀



Recommended fuel quality

Super unleaded (max. 15 % ethanol, E15)
89 AKI (95 ROZ/RON)
90 AKI

Refueling procedure

WARNING

Fuel is highly flammable

Fire and explosion hazard

- Do not smoke. Never bring a naked flame near the fuel tank.◀

ATTENTION

Contact of fuel and plastic surfaces

Damage to surfaces (become unattractive or cloudy)

- Immediately clean plastic surfaces after contact with fuel.◀
- Park motorcycle, ensuring that support surface is firm and level.
- Open protective cap.



- Unlock fuel tank with ignition key and fold up.



WARNING

Escaping of fuel due to expansion under exposure to heat with overfilled fuel tank

Accident hazard

- Do not overfill the fuel tank.◀
- Refuel with a fuel meeting the specifications below, continuing until fuel is no higher than lower edge of filler neck.

NOTICE

If refueling is carried out after running on fuel reserve, the resulting filling capacity must be

greater than the fuel reserve so that the new fill level is detected and the fuel reserve indicator light is switched off.◀



Usable fuel quantity

Approx. 7 gal (Approx. 26.5 l)



Reserve fuel quantity

Approx. 1.1 gal (Approx. 4 l)

- Press fuel tank cap down firmly to close.
- Remove vehicle key and close protective cap.

Refueling procedure

– with Keyless Ride^{OE}

Requirement

Steering lock is unlocked.



WARNING

Fuel is highly flammable

Fire and explosion hazard

- Do not smoke. Never bring a naked flame near the fuel tank.◀



WARNING

Escaping of fuel due to expansion under exposure to heat with overfilled fuel tank

Accident hazard

- Do not overfill the fuel tank.◀



ATTENTION

Contact of fuel and plastic surfaces

Damage to surfaces (become unattractive or cloudy)

- Immediately clean plastic surfaces after contact with fuel.◀

- Make sure ground is level and firm and place motorcycle on side stand.



NOTICE

The available fuel tank capacity can only be used optimally when the motorcycle is standing upright on the side stand.◀

- with Keyless Ride^{OE}
- Switch off ignition (▶▶▶ 53).



NOTICE

After the ignition is switched off, the fuel filler cap can be opened within the specified run-on time even without the radio-operated key being within the reception area.◀



After-running period for opening the fuel filler cap

2 min

- » There are **2 ways** to open the fuel filler cap:
- Within the after-running period.
- After the after-running period expires.

Version 1

- with Keyless Ride^{OE}

Requirement

Within the run-on time

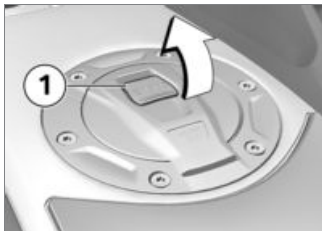

- Slowly pull lug **1** of fuel filler cap upward.
- » Fuel filler cap unlocked.
- Open fuel filler cap completely.

Version 2

- with Keyless Ride^{OE}

Requirement

After run-on time expires

- Bring radio-operated key into reception range.
- Slowly pull up lug **1**.
- » The indicator light for the radio-operated key flashes as long as the radio-operated key is being searched for.
- Slowly pull lug **1** of fuel filler cap upward again.
- » Fuel filler cap unlocked.
- Open fuel filler cap completely.



- Refuel with a fuel meeting the specifications above, continuing until fuel is no higher than lower edge of filler neck.



NOTICE

If refueling is carried out after running on fuel reserve, the resulting filling capacity must be greater than the fuel reserve so that the new fill level is detected and the fuel reserve indicator light is switched off.◀

NOTICE

The "usable fuel quantity" specified in the technical data is the fuel quantity, which can be refueled if the fuel tank was completely emptied, i.e., if the engine dies off due to lack of fuel. ◀



Usable fuel quantity

Approx. 7 gal (Approx. 26.5 l)



Reserve fuel quantity

Approx. 1.1 gal (Approx. 4 l)

- Press fuel filler cap of fuel tank down firmly.
- » Fuel filler cap audibly engages.
- » Fuel filler cap automatically locks after run-on time expires.
- » The engaged fuel filler cap locks immediately when the

steering lock is locked or during starting.

Securing motorcycle for transport

- Protect against scratching all components where tensioning straps are routed. For example, use adhesive tape or soft cloths.



ATTENTION

Motorcycle tips to the side when raising

Component damage cause by tipping over

- Secure the motorcycle against tipping to the side, preferably with the assistance of a second person. ◀
- Push motorcycle onto transport surface, and do not place on side stand or center stand.



ATTENTION

Improper placement of the tensioning straps

Damage to brake lines, cables, bearings and trim panels

- Route tensioning straps carefully.

- Protect painted components from scratching with a cloth.◀
- Pass the straps on left and right through the front suspension and strap the motorcycle down.

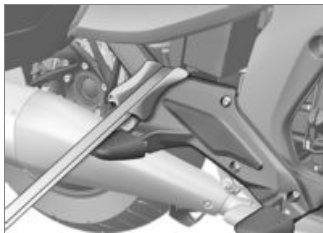

- Place straps at rear on both sides on rear frame and tension.
- Do not pull the straps over the footrests.
- Tighten all straps evenly.

Technology in detail

General notes.....	108
Antilock Braking System (ABS)	108
Dynamic Traction Control (DTC).....	111
Electronic chassis and suspension adjustment (D-ESA)	113
Riding mode	113
Tire pressure control (TPC/RDC).....	115
Shift assistant.....	116
Hill Start Control	117

General notes

More information on the topic of technology is available at:

bmw-motorrad.com/technology

Antilock Braking System (ABS)

Partially integral brake

Your motorcycle is equipped with a partially integral brake configuration. Both front and rear brakes are applied simultaneously when you pull the handbrake lever.

The footbrake lever acts only on the rear brake.

The BMW Motorrad Integral ABS adapts the braking force distribution between the front and rear wheel brake to the loading of the motorcycle during braking.



ATTENTION

Attempt at a burn-out despite integral function

Damage to rear-wheel brake and clutch

- Do not perform burn-out. ◀

How does ABS work?

The maximum braking force that can be transferred to the road surface is partially dependent on the friction coefficient of the road surface. Gravel, ice, snow and wet roads offer a considerably poorer friction coefficient than a dry, clean asphalt surface. The poorer the friction coefficient of the road surface is, the longer the braking distance will be.

If the maximum transferrable braking force is exceeded when the driver increases the brake pressure, the wheels begin to lock and driving stability is lost, and a fall can result. Before this

situation occurs, ABS intervenes and adjusts the brake pressure to the maximum transferrable braking force. This enables the wheels to continue to turn and maintains driving stability regardless of the road surface condition.

What happens when rough roads are encountered?

Bumpy or rough roads can briefly lead to a loss of contact between the tires and the road surface, until the transferable braking force is reduced to zero. If braking is carried out in this situation, ABS must reduce the brake pressure to ensure driving stability when restoring contact to the road. At this point in time, the BMW Motorrad Integral ABS must assume extremely low friction coefficients (gravel, ice, snow) so that the running wheels

turn in every imaginable case and the driving stability is ensured. After detecting the actual conditions, the system adjusts the optimum brake pressure.

How is the BMW Motorrad Integral ABS noticeable to the rider?

If the ABS system must reduce the braking forces due to the conditions described above, then vibrations can be felt at the handbrake lever.

If the handbrake lever is pulled, then braking pressure is built up at the rear wheel with the integral function. If the footbrake lever is first actuated after this, the brake pressure already built up can be felt earlier than the counter-pressure, than when the footbrake lever is actuated before or together with the handbrake lever.

Lifting off rear wheel

Even during severe braking, a high level of tire grip can mean that the front wheel does not lock up until very late, if at all. Consequently, ABS does not intervene until very late, if at all. Under these circumstances the rear wheel can lift off the ground, and the outcome can be a high-siding situation in which the motorcycle can flip over.

WARNING

Lifting off of the rear wheel due to heavy braking

Accident hazard

- When braking heavily, bear in mind that the ABS control cannot always be relied on to prevent the rear wheel from lifting off the ground. ◀

What are the design characteristics of the BMW Motorrad Integral ABS?

The BMW Motorrad Integral ABS ensures driving stability on any surface within the limits of driving physics. The system is not optimized for special requirements resulting under extreme weather conditions offroad or on the race-track.

Special situations

To detect the tendency of the wheels to lock up, the speeds of the front and rear wheel are compared. If implausible values are detected over a longer period of time, the ABS function is deactivated for safety reasons and an ABS fault is indicated. The condition for a fault code is the completed self-diagnosis.

In addition to problems on the BMW Motorrad Integral ABS,

unusual driving conditions can also lead to a fault code.

Unusual driving conditions:

- Heating up on the main or auxiliary stand at idle or with gear engaged.
- Rear wheel locked by the engine brake for a lengthy period, for example while descending on a loose surface.

Should a fault code result due to one of the driving conditions described above, the ABS function can be reactivated by switching the ignition off and then on again.

How important is regular maintenance?



WARNING

Failure to have maintenance performed on the brake system regularly.

Accident hazard

- To ensure that the ABS is in a properly maintained condition, it is vital that the specified service intervals be observed. ◀

Reserves for safety

But remember: the potentially shorter braking distances which BMW Motorrad Integral ABS permits must not be used as an excuse for careless riding. ABS is primarily a means of ensuring a safety margin in genuine emergencies.

Be careful in curves! When you apply the brakes on a corner, the motorcycle's weight and momentum take over and even BMW Motorrad Integral ABS is unable to counteract their effects.

Further development of ABS to ABS Pro

In the past, the BMW Motorrad ABS system provided for a very high level of safety while braking during straight-ahead riding. Now ABS Pro also offers increased safety even when braking in curves. ABS Pro prevents locking-up of the wheels even in case of rapid brake actuation. ABS Pro reduces abrupt changes in steering forces, especially during panic braking, and therefore decreases the risk of unwanted wheelies occurring.

ABS control

From a technical standpoint, ABS Pro adjusts the ABS control to the angle of inclination of the motorcycle in dependence on the respective riding situation. Signals for the roll and yaw rate and the lateral acceleration are used to determine the incli-

nation of the motorcycle. The signals come from the yaw rate sensor, which is already used for Dynamic Traction Control DTC and for Dynamic ESA.

With an increasing inclination, the braking pressure gradient is increasingly limited at the start of braking. This results in a slower pressure buildup. In addition, the pressure modulation in the range of the ABS control is more uniform.

Advantages for the driver

The advantages of ABS Pro for the rider are sensitive response and high braking and riding stability with the best possible deceleration, even in curves.

Dynamic Traction Control (DTC)

How does DTC work?

The BMW Motorrad DTC compares the wheel speeds of the front and rear wheel. Differences in the relative rotation speeds allow the system to determine the slip rate, and thus the stability reserves at the rear wheel. The engine-management system adapts the engine torque when the slip limit is exceeded.



Risky riding style

Risk of accident despite DTC

- The rider is always responsible for adapting his/her driving style.
- Do not reduce the system's extra safety margin with careless riding or unnecessary risks. ◀

What is the design baseline for BMW Motorrad DTC?

BMW Motorrad DTC is designed as an assistant system for the rider and for use on public roads. The extent to which the rider affects DTC control can be considerable (weight shifts when cornering, items of luggage loose on the motorcycle), especially when style of riding takes rider and machine close to the limits imposed by physics.

The system is not optimized for the special conditions encountered under extreme weather during off-road and race-track use. You have the option of deactivating the BMW Motorrad DTC system for these circumstances.

**WARNING****Risky riding style**

Risk of accident despite DTC

- The rider is always responsible for adapting his/her driving style.
- Do not reduce the system's extra safety margin with careless riding or unnecessary risks. ◀

Special situations

As lean angles increase, acceleration potential is also progressively restricted by the laws of physics. This can result in reduced acceleration when coming out of very tight curves.

To detect spinning or slipping away of the rear wheel, the speeds of the front and rear wheel are compared and the angle is considered, for example. If these values are detected to be implausible for a long period,

a replacement value is used for the angle and the DTC function is deactivated. In these cases, a DTC error is displayed. A self-diagnosis routine must be completed before the error will be displayed.

The BMW Motorrad DTC can issue an error message under the exceptional riding conditions outlined below.

Unusual riding conditions:

- Driving on the rear wheel (wheelie) for a longer period with DTC deactivated.
- Rear wheel spinning in place with front brake engaged (burn out).
- Heating up on an auxiliary stand at idle speed or with gear engaged.

If the front wheel loses contact to the ground during extreme acceleration, the DTC reduces

the engine torque until the front wheel touches the ground again. BMW Motorrad recommends that you respond to this condition by twisting back the throttle grip somewhat to return to stable dynamic operating conditions as quickly as possible.

On a slippery surface, the throttle grip should never be suddenly twisted back completely unless the clutch is disengaged at the same time. The engine braking torque can cause the rear wheel to slip, resulting in an unstable driving state. This case cannot be controlled by the BMW Motorrad DTC.

Electronic chassis and suspension adjustment (D-ESA)

Adjustment options

Using the Dynamic ESA electronic suspension adjustment system you can easily adjust your motorcycle to the load being carried and the road condition.

Using leveling sensor, Dynamic ESA detects movements of the running gear and responds to them by adjusting the damping valves. As a result, the chassis and suspension is adjusted to the conditions of the surface. Starting from the ROAD basic setting, the comfortable damping can also be made more comfortable with CRUISE.

The chassis and suspension setting depends on the selected riding mode. Damping set by the

riding mode can be changed by the rider.

Dynamic ESA calibrates itself at regular intervals when the vehicle is at a standstill and the engine is running to ensure that the system is functioning properly. The chassis and suspension cannot be adjusted while the system is being calibrated.

Riding mode

Selection

Three riding modes allow the motorcycle's characteristics to adapt to the prevailing weather conditions, the road and traffic, and the rider's style of riding:

- RAIN
- ROAD
- DYNAMIC

Each riding mode affects the behavior of the motorcycle in a different way. DTC can be switched off in each mode; the explanations below invariably refer to conditions with the system switched ON. The last selected riding mode is reactivated automatically after the ignition is switched off and on again.

The following always applies: The sportier the selected mode, the more directly the engine power can be utilized. At the same time, the level of rider assistance that the DTC system offers decreases accordingly. Therefore, consider the following when selecting the riding mode: The sportier the setting, the more demanding the requirements for the driving skill of the rider are!

RAIN

The engine output is only partially available. Power increase when you open the throttle is reserved, engine response is correspondingly soft.

The DTC system intervenes early enough to prevent the rear wheel from spinning. On roads with high to medium friction coefficients (dry and wet asphalt to dry cobblestones) the vehicle remains very stable; movements of the tail are clearly perceptible only on slippery roads (wet bitumen or wet cobblestones).

ROAD

In this mode the full engine output is available. Power increase when you open the throttle is more direct than in RAIN mode, the engine responds more rapidly.

DTC system intervention is later than in RAIN mode. The vehi-

cle remains stable on road surfaces with high to moderate coefficients of friction (traction) (dry and wet asphalt as well as dry cobblestones). Slight rear-wheel drift is perceptible. Movements of the tail are clearly perceptible on slippery road surfaces (wet bitumen or wet cobblestones).

DYNAMIC

The DYNAMIC mode is the sportiest mode.

Power increase and engine response are the same as in ROAD mode. However, the driver's request is implemented much more directly.

DTC system intervention is even later, which means that even on dry asphalt drifting is possible under sharp acceleration when cornering.

Changing setting

It is only possible to change functions in the engine control and the DTC there is no drive torque being applied to the rear wheel.

To stop transmission of drive torque,

- motorcycle must be stopped with the ignition switched on.

or

- throttle grip must be twisted back.

or

- the clutch must be actuated.

First the desired riding mode is preselected. The new selection is not activated until the specified conditions are present in all affected systems.

The selection menu does not disappear in the display until the

riding mode has been switched over.

Tire pressure control (TPC/RDC)

– with tire pressure monitor (TPM)^{OE}

Operation

A sensor located in each tire monitors the air temperature and the inflation pressure inside the tire and transmits this information to the control unit.

The sensors are equipped with a switch that suppresses transmission of the measured values until a speed of approximately 19 mph (30 km/h) is reached. Before initial reception of the tire pressure, -- is shown in the display for each tire. The sensors continue to transmit the monitored data for approx. 15 minutes after the motorcycle comes to a stop.

A fault message is generated if a TPM control unit is fitted but the wheels have no sensors.

Temperature compensation

The inflation pressure within a tire is sensitive to temperature: it responds to higher tire temperatures by increasing, and to lower temperatures by dropping. Tire temperature, in turn, varies according to the ambient temperature as well as in response to driving style and trip duration. The tire pressures are shown temperature-compensated in the multifunction display; they refer to a tire temperature of 68 °F (20 °C). No temperature compensation is available in the inflation pressure gauges at filling stations, meaning that the measured tire inflation pressure varies according to tire temperature. As a result, the pressure figures

indicated by the gauges at filling stations will usually vary from those appearing in the multifunction display. The warmer the tire, the more the tester reading exceeds the display value.

Adjusting inflation pressure

Compare the TPC/RDC value in the multifunction display with the value on the back cover of the Rider's Manual. The difference between the two values must be compensated with the air pressure tester at the filling station.

Example: According to the Rider's Manual, the tire inflation pressure is to be 42 psi (2.9 bar), however 39 psi (2.7 bar) is shown in the multifunction display. The tester at the filling station indicates 36 psi (2.5 bar). This value must be increased by 3 psi (0.2 bar) to 39 psi (2.7 bar)

in order to produce the correct tire inflation pressure.

Shift assistant

– with Gearshift Assistant Pro^{OE}

Pro gearshift assistant

Your motorcycle is equipped with a gearshift assistant originally developed for racing but now specially adapted for touring use.

It allows you upshift and downshift under almost any load conditions and in virtually all engine-speed ranges without operating the clutch or accelerator.

Benefits

- 70-80 % of all gear changes can be performed without using the clutch.
- Less movement between pilot and pillion due to shorter gear-change intervals.

- Throttle does not have to be closed when changing gear under acceleration.
- During deceleration and downshifts (throttle plate closed) the system blips the throttle to obtain the correct engine speed.
- Shifting times are faster than when the clutch is used to change gears.

For the system to detect the rider's intention to change gear, the gearshift lever previously not operated must be moved against the force of the spring by a certain amount of "overtravel" in the desired direction with a normal to brisk action and held in that position until the gear change is completed. A further increase of the force applied to the gearshift lever during the gear-shift operation is not necessary. After the gear change is completed, the gearshift lever must be fully re-

leased before the gearshift assistant Pro can execute a new gear change. When changing gear using the gearshift assistant function, the throttle setting (throttle grip position) must be kept constant before and during the gear-shift operation. Changing the accelerator twist-grip position during the gear-shift operation may cause the function to abort and/or the gear change to fail. No support is provided by the gearshift assistant during gear changes made using the clutch.

Downshifts

- Downshifts are assisted up to the speed at which the engine reaches maximum rpm in the gear to be engaged. Overrevving is thus prevented.



Maximum engine speed

max 8500 min⁻¹

Upshifts

- Upshifting is supported until the idling speed is reached in the target gear.
- This prevents the idling speed from being dropped below.



Idle speed

900±50 min⁻¹ (Engine at operating temperature)

Hill Start Control

Hill Start Control function

Hill Start Control Pro prevents uncontrolled rollback on slopes by intervening specifically in the partial integral ABS brake system without the driver having to

continuously operate the brake lever. When Hill Start Control Pro is activated, pressure builds up in the rear brake system so that the motorcycle remains stationary on a sloping surface.

The brake pressure in the brake system depends on the gradient.

The effect of brake pressure on behavior when driving off

- Stopping on a slight incline builds up only a small amount of brake pressure. The brake is released quickly when driving off, making it possible to drive off more smoothly. Additional turning of the throttle grip is hardly necessary.
- Stopping on a steeper slope increases the amount of brake pressure built up. The brake is a bit slower to release when driving off. More torque is required to drive off, making additional turning of the throttle grip necessary.

Behavior when the vehicle is rolling or slipping

- The brake pressure increases when the vehicle is rolling with Hill Start Control Pro active.
- If the rear wheel slips, the brake is released again after approx. 1 m. This prevents slipping down the hill with the rear wheel locked up, for example.

Releasing the brake when stopping the engine

Hill Start Control Pro is deactivated when the engine is switched off using the emergency-off switch or when the side stand is folded out. In addition to indicator and warning lights, the following vehicle behavior should make the driver aware that Hill Start Control Pro is deactivated:

Brake warning jerk

- The brake is released briefly and is immediately reactivated.
- This causes a jerking behavior that the driver can feel.
- The partial integral ABS brake system sets a speed of approx. 3 km/h.
- The driver must brake the vehicle manually.
- After two minutes, or when the brake is applied, Hill Start Control Pro is deactivated completely.



NOTICE

When the ignition is switched off, the holding pressure is built up immediately and without brake warning jerk.◀

Maintenance

General instructions.....	120
Tool kit	120
Front wheel stand	120
Engine oil	122
Brake system	123
Clutch	127
Coolant	127
Tires	128
Rims and tires	129
Wheels	129
Light sources	136
Jump-starting.....	141
Battery.....	142
Fuses	145
Diagnostic connector	146

General instructions

The 'Maintenance' chapter describes work involving the checking and replacement of wear parts that can be performed with a minimum of effort.

If special tightening torques are to be taken into account for assembly, these are listed. An overview of all required tightening torques is contained in the chapter "Technical Data".

Information on additional maintenance and repair work is provided in the Repair Manual for your vehicle on DVD, which you can obtain from your authorized BMW Motorrad retailer.

Special tools and thorough specialized knowledge are required to carry out some of the work described here. If you are in doubt, consult an authorized workshop, preferably your authorized BMW Motorrad retailer.

Tool kit

Standard tool kit

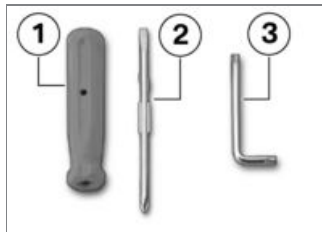

- 1 Screwdriver handle
- 2 Reversible screwdriver insert
Phillips PH1 and Torx T25
- 3 Torx wrench, T25/T30
T25 on short end, T30 on long end
 - Replacing high beam light source (►► 136).
 - Removing the license plate carrier.

Front wheel stand

Mounting front-wheel stand

ATTENTION

Use of the BMW Motorrad front wheel stand without an additional center or auxiliary stand

Component damage cause by tipping over

- Place the motorcycle on the center stand or an auxiliary stand before lifting it with the BMW Motorrad front wheel stand. ◀
- Use basic stand with part number (83 30 0 402 241) in combination with front-wheel adapter (83 30 0 402 243).
- Make sure ground is level and firm and place motorcycle on its center stand.

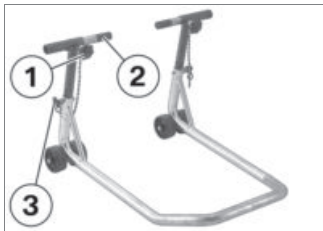

- Loosen locating screws **1**.
- Slide the two support bars **2** outward, continuing until the front wheel suspension fits between them.
- Use locating pins **3** to set front wheel stand to desired height.
- Center front wheel stand relative to front wheel and push it against front axle.



ATTENTION

The left mounting pin moves too much

Damage to the sensor ring of the BMW Motorrad Integral ABS

- Only push the left mounting pin so far inward that it does not touch the sensor ring. ◀
- Push two mounting pins **2** through triangles of brake caliper support toward the inside so that front wheel can still be rolled through.
- Tighten locating screws **1**.



ATTENTION

Center stand retracts if motorcycle is lifted too high.

Component damage cause by tipping over

- When raising the motorcycle, make sure that the center stand remains on the ground. ◀
- Apply uniform pressure to push front wheel stand down and raise motorcycle.

Engine oil

Check engine oil level



WARNING

Engine oil level too low

Risk of accident due to engine seizure

- Always make sure that the oil level is correct. ◀



ATTENTION

Misinterpretation of the oil filling quantity, as the oil level is temperature-dependent (the higher the temperature, the higher the oil level)

Engine damage

- Only check the oil level after a longer journey or when the engine is warm. ◀
- Make sure ground is level and firm and hold motorcycle at operating temperature vertically.

– with center stand^{OE}

- Make sure ground is level and firm and place motorcycle at operating temperature on its center stand. ◀
- Allow engine to idle until fan starts, then let it continue running for an additional minute.
- Switch off engine and wait for approximately one minute so that the oil can drain down.
- Wipe area around oil fill location to clean it.

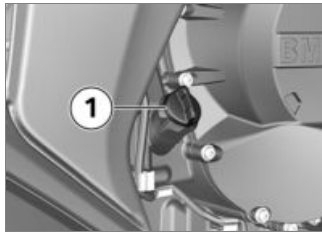

- Remove oil dipstick **1** and clean with a dry cloth.

- Position oil dipstick on oil filler opening, but do not screw in.
- Remove oil dipstick and read fluid level.

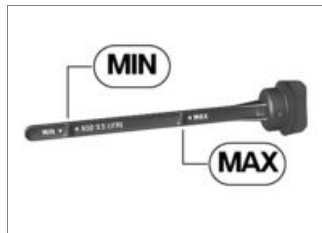

Specified level of engine oil

between MIN and MAX marking (Engine at operating temperature)



Engine oil, quantity for topping up

max 0.5 quarts (max 0.5 l) (Difference between MIN and MAX)

If oil level is below MIN mark:

- Topping up engine oil (➡ 123).

If oil level is above MAX mark:

- Have oil level corrected at an authorized service facility, preferably an authorized BMW Motorrad retailer.

- Install oil dipstick.

Topping up engine oil

- Park motorcycle, ensuring that support surface is firm and level.
- Clean area adjacent to oil fill location.

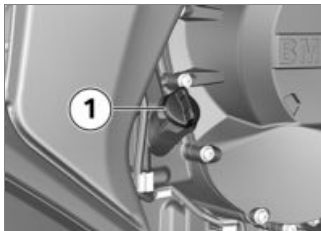

- Remove oil dipstick **1**.



ATTENTION

Use of too little or too much engine oil

Engine damage

- Always make sure that the oil level is correct.◀
- Add engine oil up to specified level.
- Check engine oil level (➡ 122).
- Install oil dipstick.

Brake system

Checking brake operation

- Make sure ground is level and firm and park motorcycle.
- Actuate the handbrake lever.
 - » Pressure point must be clearly perceptible.
- Actuate the footbrake lever.
 - » Pressure point must be clearly perceptible.

If no clear pressure points are perceptible:



ATTENTION

Improper working on the brake system

Endangering of the operating safety of the brake system

- Have all work on the brake system carried out by experts.◀
- Have the brakes checked at an authorized workshop, preferably an authorized BMW Motorrad retailer.

Check front brake pad thickness

- Make sure ground is level and firm and park motorcycle.



- Visually inspect left and right brake pads to determine their thickness. Viewing direction: between wheel and front suspension toward brake pads **1**.



Front brake-pad wear limit

min 0.04 in (min 1.0 mm)
(Only friction material without carrier plate. The wear markings (grooves) must be clearly visible.)

If the wear indicators are no longer clearly visible:



WARNING

Dropping below the minimum pad thickness

Reduced braking action, damage to the brake

- In order to ensure the operating reliability of the brake system, make sure that the brake pads are not worn beyond their minimum thickness. ◀
- Have the brake pads replaced at an authorized service facility, preferably an authorized BMW Motorrad retailer.

Check rear brake pad thickness

- Make sure ground is level and firm and park motorcycle.

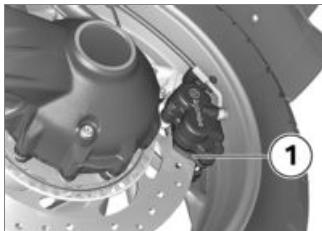

- Conduct a visual inspection of the brake pad thickness. Viewing direction: from below toward brake pads **1**.

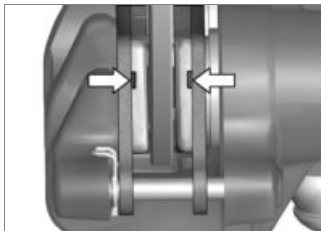

 Rear brake-pad wear limit

min 0.04 in (min 1.0 mm)
(Only friction material without carrier plate. The wear markings (grooves) must not be reached.)

If the wear indicating mark is no longer visible:

 **WARNING**

Dropping below the minimum pad thickness

Reduced braking action, damage to the brake

- In order to ensure the operating reliability of the brake system, make sure that the brake pads are not worn beyond their minimum thickness. ◀
- Have the brake pads replaced at an authorized service facility, preferably an authorized BMW Motorrad dealer.

Checking front brake fluid level

 **WARNING**

Insufficient brake fluid in the brake-fluid reservoir

Considerably reduced braking performance caused by air in the brake system

- Adjust the riding mode immediately until the fault is rectified.
- Check brake fluid level regularly. ◀

- Make sure ground is level and firm and hold motorcycle vertically.
- Move handlebars into straight-ahead position.

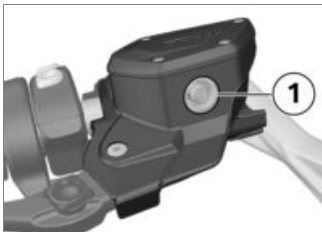

- Check brake fluid level in front brake-fluid reservoir **1**.

NOTICE

The brake fluid level in the brake-fluid reservoir drops due to brake pad wear.◀



Front brake fluid level

Brake fluid, DOT4

The brake fluid level must not fall below the MIN mark. (Brake fluid reservoir horizontal, motorcycle standing upright and handlebars straight ahead.)

If brake fluid level falls below the approved level:

- Have defect corrected as soon as possible by an authorized workshop, preferably an authorized BMW Motorrad retailer.

Checking rear brake fluid level

WARNING

Insufficient brake fluid in the brake-fluid reservoir

Considerably reduced braking performance caused by air in the brake system

- Adjust the riding mode immediately until the fault is rectified.
- Check brake fluid level regularly.◀
 - with center stand^{OE}
- Make sure ground is level and firm and place motorcycle on its center stand.◀
- Make sure ground is level and firm and hold motorcycle vertically.

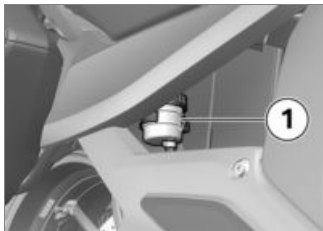

- Read brake fluid level at rear brake-fluid reservoir **1**.



NOTICE

The brake fluid level in the brake-fluid reservoir drops due to brake pad wear. ◀



Rear brake fluid level

Brake fluid, DOT4

The brake fluid level must not fall below the MIN mark. (Brake-fluid reservoir horizontal, motorcycle standing up-right.)

If brake fluid level falls below the approved level:

- Have the defect corrected as soon as possible by an authorized workshop, preferably an

authorized BMW Motorrad retailer.

Clutch

Check clutch function

- Pull back the clutch lever.
 - » Pressure point must be clearly perceptible.

If no clear pressure point can be felt:

- Have the clutch checked by an authorized workshop, preferably an authorized BMW Motorrad retailer.

Coolant

Check coolant level

- Make sure ground is level and firm and park motorcycle.
- Allow the engine to cool down.

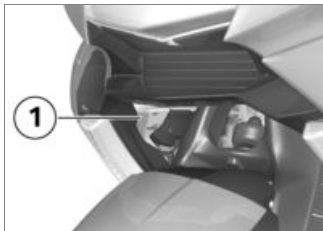

- Read off coolant level on expansion tank **1**.

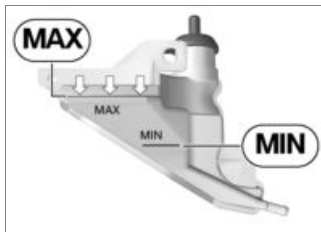

Required coolant level

Between MIN and MAX markings on the expansion tank (Engine cold)

If coolant level drops below approved level:

- Have the defect corrected as soon as possible by an authorized workshop, preferably an authorized BMW Motorrad retailer.

Tires

Checking tire pressure



WARNING

Incorrect tire inflation pressure

Poorer handling characteristic of motorcycle, reduction of tire service life

- Ensure proper tire inflation pressure. ◀
- Make sure ground is level and firm and park motorcycle.
- Check tire pressures against data below.



Tire pressure, front

42.1 psi (2.9 bar) (One-up and two-up riding with load; with cold tires)



Tire pressure, rear

42.1 psi (2.9 bar) (One-up and two-up riding with load; with cold tires)

If tire pressure is too low:

- Correct tire pressure.

Rims and tires

Check wheel rims

- Make sure ground is level and firm and park motorcycle.
- Subject wheel rims to visual inspection for defects.
- Have damaged rims checked and, if necessary, replaced by a specialist service facility, preferably an authorized BMW Motorrad retailer.

Checking tire tread depth



WARNING

Riding with heavily worn tyres

Risk of accident due to poorer rideability

- If necessary, replace the tyres before the legally specified minimum tread depth is reached.◀
- Make sure ground is level and firm and park motorcycle.
- Measure tire tread depth in main tread grooves with wear indicating marks.



NOTICE

Tread wear marks are integrated into the main grooves on every tire. If the tire tread has worn down to the level of the marks, the tire is completely worn. The locations of the marks are indicated on the edge of the tire, e.g.

by the letters TI, TWI or by an arrow.◀

When the minimum tread depth is reached:

- Replace tires concerned.

Wheels

Tire recommendation

For every size of tire, BMW Motorrad has tested and approved certain makes as roadworthy. BMW Motorrad cannot evaluate the suitability of other tires, and can therefore take no responsibility for their driving safety.

BMW Motorrad recommends only using the tires tested and approved by BMW Motorrad. Extensive information is available at your authorized BMW Motorrad retailer or on the Internet at "www.bmw-motorrad.com".

Affect of wheel sizes on suspension control systems

The wheel sizes play a major role in the ABS and DTC suspension-control systems. The diameter and width of the wheels stored in the control unit have particular significance as the basis for all necessary calculations. A change in these sizes resulting from conversion to wheels not installed as standard equipment can seriously affect the control efficiency of these systems.

The sensor rings are essential for correct wheel speed detection; they too must match the motorcycle's control systems and consequently cannot be replaced. If you want to equip your motorcycle with different wheels, please contact a specialist service facility, preferably a BMW Motorrad retailer. In some cases the data stored in the

control units can be adapted for the new wheel sizes.

TPC/RDC sticker

- with tire pressure monitor (TPM)^{OE}

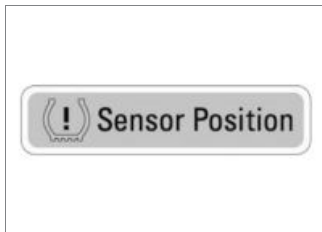

ATTENTION

Improper tire removal

Damage to the TPC/RDC sensors

- Inform a specialist service facility or an authorized BMW Motorrad retailer on the fact that the wheel is equipped with a TPC/RDC sensor.◀

On motorcycles equipped with TPC/RDC, a corresponding sticker is located on the wheel rim at the position of the TPC/RDC sensor. During a tire change it must be ensured that the TPC/RDC sensor is not damaged. Inform the BMW Motorrad retailer or the authorized workshop of the TPC/RDC sensor.

Removing front wheel

- Make sure ground is level and firm and place motorcycle on its center stand.



- Remove screws **1** on left and right.
- Pull out the front wheel cover to the front.



- Unclip retaining clip **1** of the sensor cable from the brake line.

- Remove cable tie **2**.
- Mask off area of wheel rim that could be scratched in process of removing brake calipers.

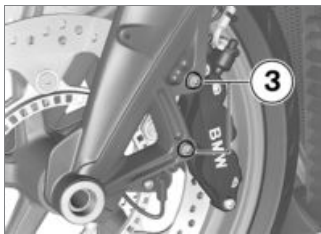

ATTENTION

Unintentional pressing together of brake pads

Component damage when mounting the brake caliper or when pressing the brake pads apart

- Do not actuate the brakes with the brake caliper removed. ◀

- Remove screws **3** of brake calipers on left and right.

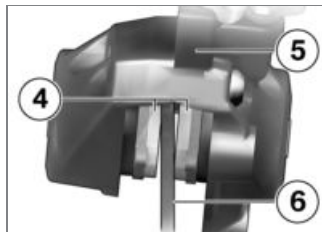

- Push brake pads **4** apart slightly by rocking brake caliper **5** back and forth against brake disk **6**.
- Carefully pull brake calipers back and out until clear of brake disks.

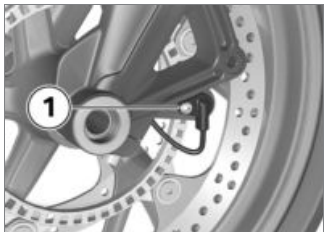

- Remove screw **1** and take wheel speed sensor out of bore.
- Raise front of motorcycle, preferably using a BMW Motorrad front wheel stand, continuing until the wheel rotates freely.
- Mounting front-wheel stand (▶▶▶ 120).

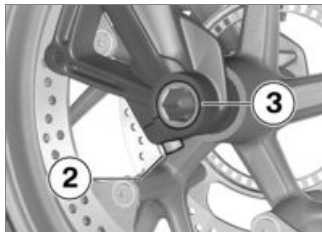

ATTENTION

Incorrect spacing between the sensor ring and wheel speed sensor caused by poorly aligned threaded bushing in the front suspension

Damage to the wheel speed sensor. ABS malfunction

- The left clamp fixes the threaded bushing in position and must not be loosened or removed.◀
- Remove right-hand axle clamping screw **2**.

- Remove quick-release axle **3** while supporting wheel.
- Roll front wheel forward to remove it.

Installing front wheel



WARNING

Use of a wheel which does not comply with series specifications

Malfunctions during control interventions by ABS and DTC

- Please see the information on the effect of wheel sizes on the ABS and DTC chassis control systems at the beginning of this chapter.◀



ATTENTION

Tightening of screwed connections with incorrect tightening torque

Damage or loosening of screwed connections

- Always have the tightening torques checked by a specialized workshop, preferably an authorized BMW Motorrad retailer.◀

ATTENTION

Front wheel installation opposite the running direction

Accident hazard

- Observe running direction arrows on tire or rim.◀
- Roll front wheel into front suspension.

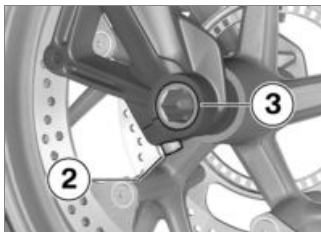

- Lift front wheel and install quick-release axle **3** with torque.

 Quick-release axle in threaded bush (wheel carrier)

37 lb/ft (50 Nm)

- Tighten the right-hand axle clamping screw **2** with the specified torque.

 Clamping screw for quick-release axle to wheel carrier

14 lb/ft (19 Nm)

- Remove front-wheel stand.

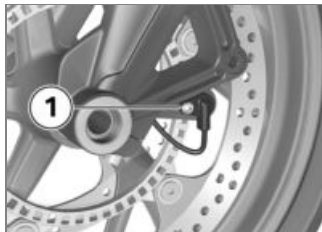

- Insert ABS sensor into socket and fit screw **1**.
- Slide the brake calipers onto the brake rotors.



- Install securing screws **3** on left and right with specified torque.



Front brake caliper at wheel carrier

21 lb/ft (28 Nm)



- Clip retaining clip **1** of the sensor cable to the brake line.
- Secure new cable tie **2**.
- Remove adhesive tape from wheel rim.
- Press handbrake lever firmly a number of times until resistance point is noticeable.

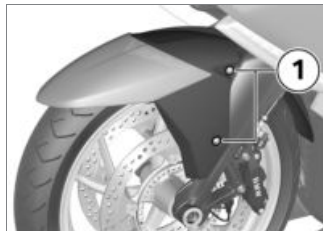

- Install front wheel cover and fit screws **1** on left and right.

Removing rear wheel

– with center stand^{OE}

- Place motorcycle on center stand, ensuring that it is resting on a firm and level support surface.

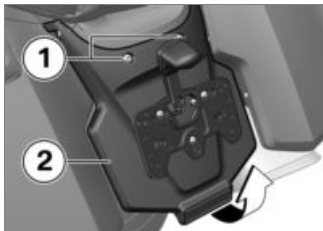

- Remove screws **1**.
- Fold up license-plate carrier **2**.
- Shift into first gear.



CAUTION

Hot exhaust system

Burn hazard

- Do not touch hot exhaust system.◀
- Remove the five bolts **1** of the rear wheel, holding the wheel as you do so.
- Lower the rear wheel to the ground and roll out toward rear.

Installing rear wheel

WARNING

Use of a wheel which does not comply with series specifications

Malfunctions during control interventions by ABS and DTC

- Please see the information on the effect of wheel sizes on the ABS and DTC chassis control systems at the beginning of this chapter.◀

ATTENTION

Tightening of screwed connections with incorrect tightening torque

Damage or loosening of screwed connections

- Always have the tightening torques checked by a specialized workshop, preferably an authorized BMW Motorrad retailer.◀

- Roll and mount rear wheel onto rear wheel support.



- Fit five bolts **1** and tighten diagonally with specified torque.



Tighten rear wheel on wheel flange

Tightening sequence: Tighten crosswise

44 lb/ft (60 Nm)

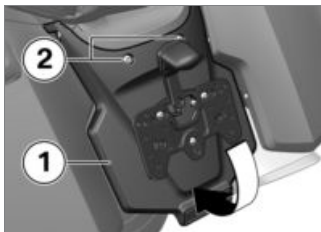

- Folding out license-plate carrier **1**.
- Install screws **2**.

Light sources

Replacing high beam light source



NOTICE

The description below steps you through the procedure for replacing the left bulb. Replacement is carried out in the same way on the right side.◀



- Turn wind deflection wing **1** out.
- Remove screw **2** and work side cover **3** to the rear and remove.

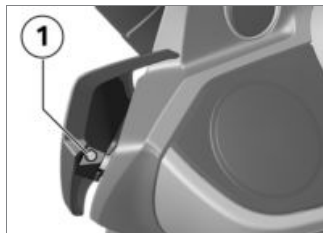

- Slacken screw **1**.



- Pull off wind deflector **2** to the rear.

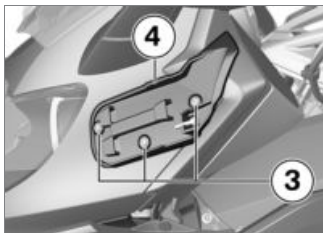

- Remove screws **3** and remove mount **4**.

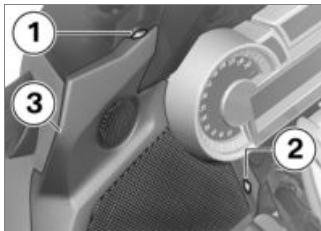

- Turn on ignition and raise windshield to its highest position.
- Remove screw **1**.
- Remove screw **2** and work hand guard **3** to the side to remove.
- Turn off the ignition and wait until the windshield has moved to its lowest position.

– with audio system US version with navigation preparation^{OE}

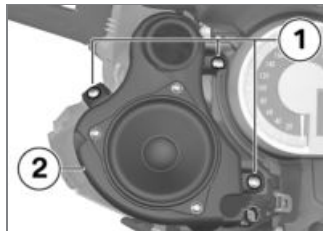

- Remove screws **1**.
- Work speaker unit **2** to the rear to remove.

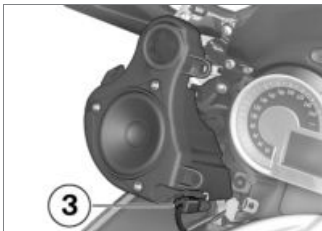

- Disconnect plug connection **3**.<

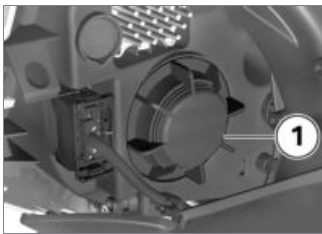

- Turn covers **1** counterclockwise to remove.

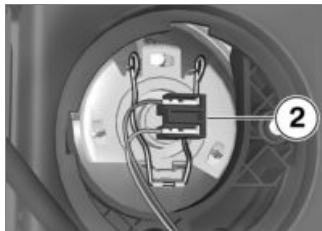

- Disconnect plug **2**.



- Release spring clip **3** at left and right and swing it up.
- Remove bulb **4**.

- Replace defective light source.

	Bulb for high-beam headlight
------------------------------------------------------------------------------------	------------------------------

H7 12 V 55 W

- To protect the glass against soiling, only grasp the light source by the base.



- Install bulb **4** while ensuring correct position of lug **5**.
- Insert spring clip **3**.



- Connect plug **2**.

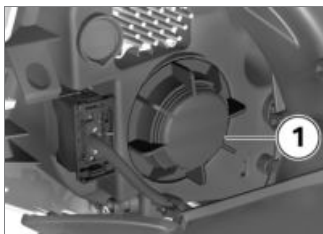

- Turn covers **1** clockwise to install.

– with audio system US version with navigation preparation^{OE}

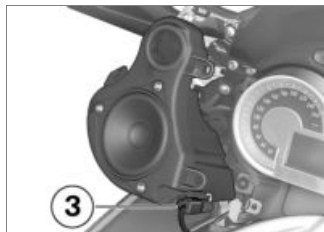

- Connect plug connection **3**.

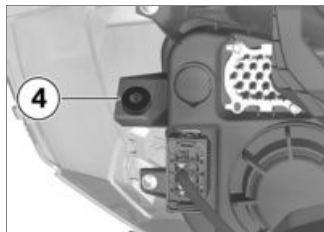

- Set speaker unit in mount **4**.



- Install screws **1**.<

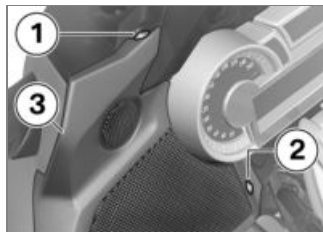

- Turn on ignition and raise windshield to its highest position.
- Fit hand guard **3** and install screw **2**.

- Install screw **1**.
- Turn off the ignition and wait until the windshield has moved to its lowest position.

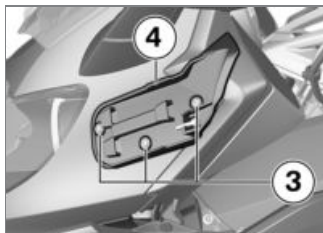

- Attach mount **4** and fit screws **3**.



- Fit wind deflector **2** from the rear, ensuring that all three lugs are firmly seated in the mount.

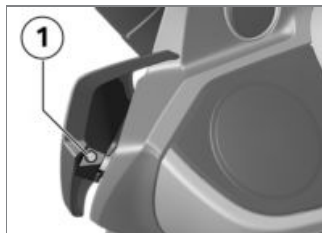

- Tighten screw **1**.

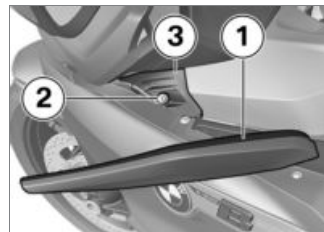

- Fit side cover **3** and install screw **2**.
- Align wind deflection wing **1**.

Replace additional LED headlight

– with additional headlight^{OE}

The auxiliary LED headlight can only be replaced as a complete unit.

- For details please contact a specialist service facility, preferably an authorized BMW Motorrad Retailer.

Replacing the LED turn indicator

LED turn indicators can be completely replaced only.

- Please contact a specialist service facility for this purpose, preferably an authorized BMW Motorrad retailer.

Replace LED tail light

The LED tail light can only be completely replaced.

- Please contact a specialist service facility for this purpose, preferably an authorized BMW Motorrad retailer.

Jump-starting

CAUTION

Touching live parts of the ignition system when the engine is running

Electrocution

- Do not touch parts of the ignition system when the engine is running. ◀

ATTENTION

Current too high when jump-starting the motorcycle

Cable fire or damage to the motorcycle electronics

- Do not jump-start the motorcycle using the power socket, only via the battery terminal. ◀

ATTENTION

Contact between crocodile clips of jump leads and motorcycle

Danger of short circuit

- Use jump leads fitted with fully insulated crocodile clips at both ends. ◀

ATTENTION

Jump-starting with a voltage higher than 12 V

Damage to the motorcycle's electronics

- The battery of the donor motorcycle must have a voltage of 12 V. ◀
- Do not disconnect the battery from the onboard electrical system when jump-starting the engine.
- Removing seat (▶▶▶ 83).
- Allow engine on support motorcycle to run while jump-starting.
- Begin by clamping one end of the red jumper cable to the positive terminal of the discharged battery and clamping the other end to the positive terminal of the donor battery.
- Then clamp one end of the black jumper cable to the

donor battery's negative terminal while connecting the other end to discharged battery's negative terminal.

- Start engine of motorcycle with discharged battery in usual way; if engine does not start, wait a few minutes before repeating attempt in order to protect starter motor and donor battery.
- Allow both engines to idle for a few minutes before disconnecting jumper cables.
- Disconnect jumper cables first from negative, then from positive terminal.
- Install seat (➔ 84).

Battery

Maintenance instructions

Correct battery maintenance combined with proper charging and storage procedures extends

the battery's service life, and is also required for warranty claims. Compliance with the points below is important in order to maximize battery life:

- Keep the surface of the battery clean and dry.
- Do not open the battery.
- Do not top up with water.
- Be sure to read and comply with the instructions for charging the battery on the following pages.
- Do not turn the battery upside down.



ATTENTION

Discharging of the connected battery by the vehicle electronics (e.g. clock)

Total discharge of battery leading to a rejection of warranty claims

- During riding breaks of more than 4 weeks, connect a trickle-charger to the battery.◀



NOTICE

BMW Motorrad has developed a trickle-charger specially designed for compatibility with the electronics of your motorcycle. Using this charger, you can keep the battery charged during long periods when the motorcycle is not being used without having to disconnect the battery from the motorcycle's onboard systems. Additional information is available at your authorized BMW Motorrad retailer.◀

Charge connected battery



ATTENTION

Charging the battery connected to the vehicle using the battery terminals

Damage to the motorcycle's electronics

- Disconnect the battery before charging on the battery terminals.◀

ATTENTION

A fully discharged battery must be charged via a power socket or extra socket.

Damage to vehicle electronics

- A fully discharged battery (battery voltage less than 12 V, indicator lights and multifunction display remain off when ignition is switched on) must always be charged directly at the poles of the **disconnected** battery.◀

ATTENTION

Unsuitable chargers connected to the power socket

Damage to charger and vehicle electronics

- Use suitable BMW chargers. The correct charger is avail-

able through your authorized BMW Motorrad retailer.◀

- Charge disconnected battery via onboard socket.

NOTICE

The motorcycle's onboard electronics know when the battery is fully charged. The onboard socket is switched off when this happens.◀

- Comply with operating instructions of charger.

NOTICE

If you are unable to charge the battery via the onboard socket, you may be using a charger that is not compatible with your motorcycle's electronics. In this case, charge the battery directly from the terminals of the battery disconnected from the vehicle.◀

Charging disconnected battery

- Charge battery using a suitable charger.
- Comply with operating instructions of charger.
- Once the battery is fully charged, disconnect the charger's terminal clips from the battery terminals.

NOTICE

In the case of longer periods when the motorcycle is not being used, the battery must be recharged regularly. See the instructions for caring for your battery. Always fully recharge the battery before returning it to use.◀

Removing battery

- Removing seat (➔ 83).

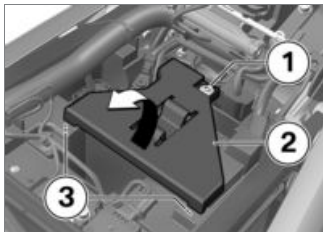

- Remove screw **1**.
- Lift up the cover **2** paying attention to the retaining lugs **3**.
- with anti-theft alarm system (DWA)^{OE}
- Switch off anti-theft alarm system if necessary.◀
- Switch off ignition.

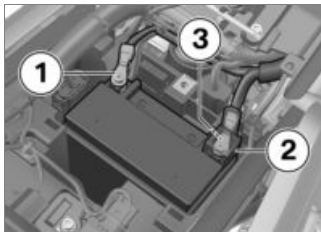

ATTENTION

Incorrect battery disconnection

Danger of short circuit

- Follow the disconnection sequence.◀
- Remove the negative battery cable **1**.
- Detach the protective cap **2** and remove the positive battery cable **3**.
- Lift the battery up and out; use tilting movements if it is difficult to move.

Install battery

- Place battery in battery compartment, positive terminal on right in direction of travel.

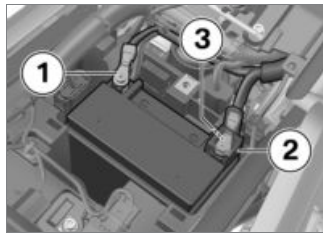

ATTENTION

Incorrect battery connection

Danger of short circuit

- Follow the installation sequence.◀
- First install positive battery cable **3**.
- Position protective cap **2**.
- Then install negative battery cable **1**.

- Switch on the ignition.
- Set time and date in menu Settings - Clock And Settings - Date.

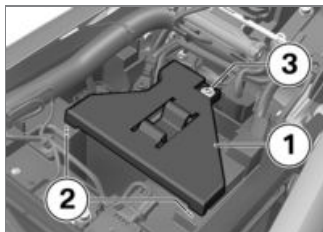

- Position cover **1** with the retaining lugs **2**.
- Install screw **3**.

 Battery bracket on rear carrier part

6 lb/ft (8 Nm)

- Install seat (▣▣▣ 84).

Fuses

Replace fuse

- Removing seat (▣▣▣ 83).
- Remove battery cover (▣▣▣ 144).
- Turn off ignition.

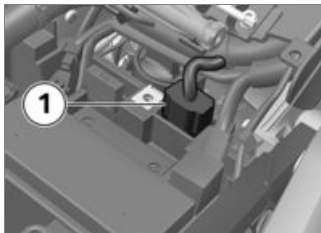

- Disconnect fuse connector **1**.

ATTENTION

Bypassing defective fuses

Risk of short circuit and fire

- Do not bypass defective fuses.
- Replace defective fuses with new fuses.◀

- Consult the fuse assignment diagram and replace the defective fuse.

NOTICE

If the fuses blow frequently, have the electrical system checked by an authorized specialized workshop, preferably an authorized BMW Motorrad retailer.◀

- Fasten fuse connector **1**.
- Installing battery cover (▣▣▣ 145).
- Install seat (▣▣▣ 84).

Fuse assignments

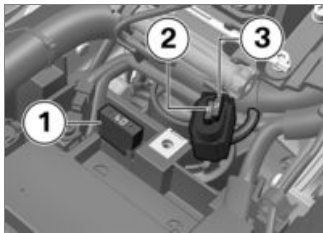

- 1** 40 A
Main fuse
 - 2** 7.5 A
Audio system
 - 3** Not in use
 - with anti-theft alarm system (DWA)^{OE}
 - or
 - with central locking system^{OE}
- 7.5 A
Alarm system
Central locking system

Diagnostic connector

Removing the diagnostic connector

⚠ CAUTION

Incorrect procedure followed when disconnecting the data link connector for the On-Board Diagnostics.

- Motorcycle experiences malfunctions
- Only have the data link connector disconnected by a specialist workshop or other authorized persons during your next BMW Service appointment.
 - Have the work performed by appropriately trained staff.
 - Refer to the vehicle manufacturer specifications.◀
 - Removing seat (▶▶ 83).

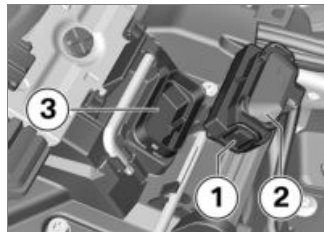

- Press locking mechanisms **1**.
 - Unplug the diagnostic connector **2** from the seat bracket **3**.
- » The diagnosis and information system interface can be connected at the diagnostic connector **2**.

Secure the data link connector

- Disconnect the diagnosis and information system interface.

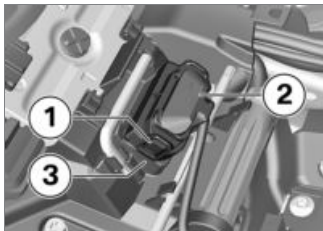

- Plug the diagnostic connector **2** into the seat bracket **3**.
 - » The locks **1** engage.
- Install seat (▮▮▮▮ 84).

Accessories

General notes.....	150
Onboard power outlets	150
Case.....	151
Navigation device	152

General notes

CAUTION

Use of products from other manufacturers

Safety risk

- BMW Motorrad cannot examine or test each product of outside origin to ensure that it can be used on or in connection with BMW motorcycles without constituting a safety hazard. Nor is this guarantee provided when the official approval of a specific country has been granted. Tests conducted by these instances cannot make provision for all operating conditions experienced by BMW motorcycles and, consequently, they are not sufficient in some circumstances.
- Use only parts and accessories approved by BMW for your motorcycle. ◀

The safety, operation and suitability of the parts and accessory products have been checked extensively by BMW. Therefore, BMW assumes responsibility for these products. BMW is not liable for unapproved parts and accessory products of any kind. Comply with legal requirements for any modifications. The motorcycle must not violate the regulations governing motorcycle approval for highway use applicable in your own country.

Note the information on the importance of wheel sizes for chassis control systems (►► 130). Your authorized BMW Motorrad retailer offers you qualified advice in choosing genuine BMW parts, accessories and other products. You can find all optional accessories from BMW Motorrad on our Internet site: "www.bmw-motorrad.com".

Onboard power outlets

Information on using onboard power sockets:

Automatic deactivation



If this warning symbol is displayed, the vehicle voltage is low. Onboard power sockets will be turned off temporarily, if necessary.

The power sockets are also switched off during starting operation and if the maximum load capacity specified in the technical data is exceeded. If multiple onboard power sockets are in operation, the total current may not exceed the maximum load capacity.

Operating electrical accessories

Auxiliary devices being operated at an onboard power socket can

only be turned on when the ignition is turned on. If the load is high, the onboard power sockets will also be turned off when the ignition is subsequently turned off. If the load is low, the onboard power sockets will remain in operation for a specified time.

Cable routing

Observe the following when routing cable from power sockets to additional devices:

- Cables must not hinder the rider's movement.
- Cables must not restrict the steering angle and driving characteristics.
- Cables must not become trapped.

Case Open case

- with central locking system^{OE}
- Open the central locking system, if necessary.<



- Turn the key in the case lock from LOCK to the position indicated by the dot.



- Press in the lock barrel **1**.
» Release lever **2** pops up.
- Pull the release lever all the way up and open the case lid.

Close case



- Pull release lever **2** all the way up.
- Close case lid. Ensure that no items are trapped between cover and case.



NOTICE

The case can also be locked if the lock is in the LOCK position. Under such circumstances, ensure that the ignition key is not in the case. ◀

- Push release lever **2** down, continuing until it engages.

- Turn key in case lock into LOCK position and remove.

Maximum payload

Observe maximum payload according to sign in the case.

If you cannot find your combination of motorcycle and case on the label, contact your BMW Motorrad Retailer.

The following values apply to the combination described here:



Payload per case

max 22 lbs (max 10 kg)

Navigation device

Install navigation device

- with audio system US version with navigation preparation^{OE}
- with navigation system^{OA}

- Switch on the ignition.



- Press button **1** to open the slot for the navigation device.
- » Slot cover pops open, windshield moves to top limit position.
- Pull slot cover up as far as it will go.
- Push out cover cap **2** from behind.



- Actuate locking mechanism **3** and remove the cover panel **4**.

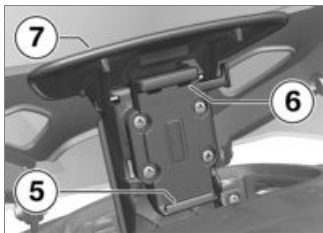

- Initially insert the navigation device into mount **5**, then press it into detent **6**.

- Check that the navigation device is secure in the cradle.
- Press cover **7** to push cradle with navigation device into the slot until it snaps into position.

Remove navigation device

– with navigation system^{OA}

- Switch on the ignition.



- Press button **1** to open the slot for the navigation device.
 - » Slot cover pops open, wind-shield moves to top limit position.

- Pull slot cover up as far as it will go.



- Operate latch **3**, pull the navigation device forward out of holder **6** and lift it up and out.



- Install cover **4**.
- Press cover **7** to push the cradle into the slot until it snaps into position.



- Insert cap **2**.

Operating navigation device

- with audio system US version with navigation preparation^{OE}
- with navigation system^{OA}
- Turn on navigation device, if necessary.
- Call up the **Navigation** menu.

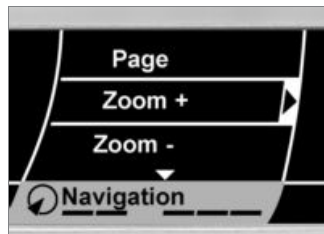

The control options for the navigation device are shown.

- **View**: you can page from view to view; the choices are main

menu, map and on-board computer.

- **Zoom +**: performs functions marked with a + sign in the navigation system. In the map view, for instance, the view zooms in on the map detail.
- **Zoom -**: performs functions marked with a - sign in the navigation system. In the map view, for instance, the view zooms out from the map detail.
- **Voice output**: the last navigation announcement is repeated. The announcement is spoken again even if automatic spoken announcements have been turned off in the settings of the navigation system.
- **Mute**: automatic spoken announcements are turned off and on.
- **Display off**: the display of the navigation device is turned off and on.

- Select desired operation and carry it out by pressing the Multi-Controller to the right.

Special functions

- with audio system US version with navigation preparation^{OE}
- with navigation system^{OA}

Due to integration of the BMW Motorrad Navigator IV into the K 1600 B series, some descriptions differ in the Navigator operating instructions.

Traffic reports (traffic information channel)

If an audio system is installed in the vehicle, it will transmit the traffic information to the Navigator. The symbol described in the Navigator operating instructions appears on the display. The BMW Motorrad audio system is unable to receive paid subscription traffic information.

Range

A distance can be defined in the fuel gauge settings for the distance covered on a full tank of fuel. Since the motorcycle transmits the remaining travel range with the current fuel level to the Navigator, manual entry of this value is no longer necessary.

Time and date

The Navigator transmits the time and date to the motorcycle. In order for the instrument cluster to accept this information, it has to be activated in the user settings of the motorcycle.

Security settings

A four-digit PIN can be used to protect the BMW Motorrad Navigator IV, BMW Motorrad Navigator V and BMW Motorrad Navigator VI from unauthorized use (Garmin Lock). When this function is activated, once the Navi-

gator GPS receiver is cradled on the motorcycle and the ignition is switched on you will receive a prompt asking whether the motorcycle should be added to the list of secure vehicles. If you confirm this question by answering "yes", the Navigator will save the vehicle identification number of this vehicle.

A maximum of five VINs can be saved in this way. Entering a PIN will no longer be required when this is activated by turning on the ignition switch in any of these vehicles. Removing the Navigator from the motorcycle while the Navigator is on will prompt a request for the PIN for reasons of security.

Screen brightness

Screen brightness is adjusted by the motorcycle while the unit is cradled. Manual input is not possible.

Care

Care products	158
Washing your motorcycle	158
Cleaning sensitive motorcycle parts	159
Paint care	160
Protective wax coating	160
Store motorcycle	160
Return motorcycle to use	160

Care products

BMW Motorrad recommends that you use cleaning and care products available at your authorized BMW Motorrad retailer. BMW CareProducts have been materials tested, laboratory tested, and field tested and provide optimum care and protection for the materials used in your vehicle.



ATTENTION

Use of unsuitable cleaning and care agents

Damage to motorcycle parts

- Do not use any solvents such as nitro thinners, cold cleaners, fuel or similar, and do not use cleaning agents that contain alcohol. ◀

Washing your motorcycle

BMW Motorrad recommends that you use BMW Insect Remover to soften and wash off insects and stubborn dirt from painted parts before washing the motorcycle.

To prevent stains, do not wash the motorcycle immediately after it has been exposed to bright sunlight and do not wash it in the sun.

Make sure that the motorcycle is washed frequently, especially during the winter months.

To remove road salt, clean the motorcycle with cold water immediately after completion of every trip.



WARNING

Damp brake disks and brake pads after washing the mo-

torcycle, after riding through water or in the rain

Poorer braking action, accident hazard

- Brake early until the brake rotors and brake pads are dry. ◀



ATTENTION

Increased effect of salt caused by warm water

Corrosion

- Only use cold water to remove road salt. ◀



ATTENTION

Damage caused by high water pressure from high-pressure cleaners or steam-jet devices

Corrosion or short circuit, damage to labels, to seals, to hydraulic brake system, to the electrical system and the seat

- Exercise caution when using high-pressure or steam-jet devices. ◀

Cleaning sensitive motorcycle parts

Plastics



Use of unsuitable cleaning agents

Damage to plastic surfaces

- Do not use abrasive cleaners or cleaners containing alcohol or solvents.
- Do not use insect sponges or sponges with a hard surface. ◀

Fairings and panels

Clean trim panel components with water and BMW Motorrad solvent cleaner.

Windshields and lenses are manufactured in plastic

Clean off dirt and insects with a soft sponge and plenty of water.



Soften stubborn dirt and dead insects by covering the affected areas with a wet cloth. ◀

Chrome

Carefully clean chrome parts with plenty of water and BMW Motorrad Care Products motorcycle cleaner. This is particularly important in the case of road salt.

Use BMW Motorrad metal polish for additional treatment.

Radiator

Clean the radiator regularly to prevent overheating of the engine due to inadequate cooling.

For example, use a garden hose with low water pressure.



Bending of radiator fins

Damage to radiator fins

- When cleaning, ensure that the cooler fins are not bent. ◀

Rubber

Treat rubber components with water or BMW rubber protection coating agent.



Use of silicone sprays for care of rubber seals

Damage to rubber seals

- Do not use silicone sprays or care products that contain silicone. ◀

Paint care

Washing the motorcycle regularly will help counteract the long-term effects of substances that damage the paint, especially if your motorcycle is ridden in areas with high air pollution or natural sources of dirt, such as tree resin or pollen.

However, remove particularly aggressive materials immediately; otherwise changes in the paint or discoloration can occur. These include spilled fuel, oil, grease and brake fluid as well as bird droppings. BMW Motorrad recommends using a solvent cleaner and then applying a BMW Motorrad high gloss polish to preserve the paint.

Contamination on the paint finish is particularly easy to see after the motorcycle has been washed. Remove this type of soiling with cleaning naphtha or spirit on a clean cloth or cotton

ball. BMW Motorrad recommends removing tar stains with BMW tar remover. Then add a protective wax coating to the paint at these locations.

Protective wax coating

Apply a preservative when water fails to bead up on the painted surface.

BMW Motorrad recommends BMW Motorrad high gloss polish or agents that contain carnauba or synthetic wax to protect the paint finish.

Store motorcycle

- Clean the motorcycle.
- Completely fill the motorcycle's fuel tank.
- Removing battery (▣▣▣ 144).

- Spray the brake and clutch lever, and the center and side stand pivots with a suitable lubricant.
- Protect metal and chrome-plated parts with an acid-free grease (Vaseline).
- Park motorcycle in a dry room, raising it to remove weight from both wheels (preferably using the front wheel and rear-wheel stand offered by BMW Motorrad).

Return motorcycle to use

- Remove the protective wax coating.
- Clean the motorcycle.
- Install battery (▣▣▣ 144).
- Observe checklist (▣▣▣ 94).

Technical data

Troubleshooting chart	162
Threaded fasteners	163
Fuel.....	164
Engine oil	164
Engine	165
Clutch	166
Transmission	166
Rear-wheel drive.....	167
Frame	167
Suspension	168
Brakes	168
Wheels and tires	169
Electrical system.....	171
Anti-theft alarm system	173
Dimensions	174

Weights.....	174
Performance data	175

Troubleshooting chart

Engine does not start.

Possible cause	Remedy
Side stand is extended	Retract side stand.
Gear engaged and clutch not disengaged	Place transmission in neutral or disengage clutch.
No fuel in tank	Refueling (▶▶▶ 101).
Battery drained	Charge battery.
Overheating protection for starter motor has activated. Starter motor can only be actuated for a limited period.	Leave the starter motor to cool down for around 1 minute until it becomes available again.

Threaded fasteners

Front wheel	Value	Valid
Front brake caliper at wheel carrier		
M8 x 30 - 10.9	21 lb/ft (28 Nm)	
Clamping screw for quick-release axle to wheel carrier		
M8 x 30	14 lb/ft (19 Nm)	
Quick-release axle in threaded bush (wheel carrier)		
M24 x 1.5	37 lb/ft (50 Nm)	
Rear wheel	Value	Valid
Tighten rear wheel on wheel flange		
M10 x 1.25 x 40	Tightening sequence: Tighten cross-wise	
	44 lb/ft (60 Nm)	

Fuel

Recommended fuel quality	Super unleaded (max. 15 % ethanol, E15) 89 AKI (95 ROZ/RON) 90 AKI
Usable fuel quantity	Approx. 7 gal (Approx. 26.5 l)
Reserve fuel quantity	Approx. 1.1 gal (Approx. 4 l)
Fuel consumption	Approx. 41 mpg (Approx. 5.7 l/100 km), according to WMTC

Engine oil

Engine oil, capacity	Approx. 1.2 gal (Approx. 4.5 l), with filter replacement
Specification	SAE 5W-40, API SL/JASO MA2, Additives (for instance, molybdenum-based substances) are prohibited, because they would attack the coatings on engine components, BMW Motorrad recommends BMW Motorrad ADVANTEC Ultimate oil.

BMW recommends **ADVANTEC**
ORIGINAL BMW ENGINE OIL

Engine

Engine number location	Above oil filler neck
Engine type	166EA
Engine design	Transverse in-line six cylinder four-stroke engine with four valves per cylinder and two overhead camshafts; liquid cooling, electronic fuel injection, integral six-speed cassette gearbox, dry-sump lubrication.
Displacement	1649 cc (1649 cm ³)
Cylinder bore	2.8 in (72.0 mm)
Piston stroke	2.7 in (67.5 mm)
Compression ratio	12.2:1
Rated output	160 hp (118 kW), at engine speed: 7750 min ⁻¹
Torque	129 lb/ft (175 Nm), at engine speed: 5250 min ⁻¹
Maximum engine speed	max 8500 min ⁻¹
Idle speed	900 \pm 50 min ⁻¹ , Engine at operating temperature
Emission standard	Euro 4

Clutch

Clutch design	Multi-disc oil bath
---------------	---------------------

Transmission

Transmission design	Claw-shifted 6-speed transmission with helical-cut splines
Transmission gear ratios	1.617, Primary gear ratio 2.230, 1st gear 1.641, 2nd gear 1.319, 3rd gear 1.101, 4th gear 0.926, 5th gear 0.788, 6th gear 0.913 (drive 1.258 K), Transmission output ratio

Rear-wheel drive

Type of final drive	Shaft drive with bevel gears
Type of rear suspension	Cast-aluminum single swing arm with BMW Motorrad paralever
Number of teeth in bevel gears (gear ratio)	2.750 (33:12)

Frame

Frame design	Aluminum composite bridge frame, integrated engine
Location of type plate	Wheel carrier, front top right
Location of the vehicle identification number	Rear main frame side section, right, over swinging arm bearing, facing in direction of travel

Suspension

Front wheel

Type of front suspension	BMW Motorrad Duolever
Design of the front-wheel suspension	Central suspension strut with electrically adjustable damping.
Spring travel, front	4.5 in (115 mm), on wheel

Rear wheel

Type of rear suspension	Central spring strut with coil spring, adjustable rebound-stage damping and spring preload
Spring travel, rear	4.9 in (125 mm), on wheel

Brakes

Front wheel

Type of front brake	Hydraulically operated twin-rotor disk brake with 4-piston fixed calipers and floating brake discs
Front brake pad material	Sintered metal
Front brake-disk thickness	0.2 in (5.0 mm), New min 0.18 in (min 4.5 mm), Wear limit
Free travel of brake actuation (Front wheel brake)	0.09...0.11 in (2.3...2.7 mm), Measuring point on the piston

Rear wheel

Type of rear brake	Hydraulically operated disk brake with 2-piston floating caliper and fixed brake disk
Rear brake pad material	Organic
Rear brake-disk thickness	0.22 in (5.5 mm), New min 0.19 in (min 4.9 mm), Wear limit
Blow-by clearance of footbrake lever	min 0.04 in (min 1 mm), Measuring point between piston and pushrod

Wheels and tires

Recommended tire combinations	An overview of the current tire approvals is available from your authorized BMW Motorrad retailer or on the Internet at bmw-motorrad.com .
Speed category of front/rear tires	W, minimum requirement: 168 mph (270 km/h)

Front wheel

Front wheel design	Cast aluminum
Front-wheel rim size	3.50" x 17"
Front tire designation	120/70 ZR 17
Load index for front tire	At least 58
Front wheel load at unladen weight	362 lbs (164 kg)
Permissible front wheel load	max 467 lbs (max 212 kg)
Permissible front-wheel imbalance	max 0.2 oz (max 5 g)

Rear wheel

Rear wheel design	Cast aluminum
Rear-wheel rim size	6.00" x 17"
Rear tire designation	190/55 ZR 17
Load index for rear tire	At least 75
Rear wheel load at unladen weight	379 lbs (172 kg)
Permissible rear wheel load	max 811 lbs (max 368 kg)
Permissible rear-wheel imbalance	max 1.6 oz (max 45 g)

Tire inflation pressure

Tire pressure, front	42.1 psi (2.9 bar), One-up and two-up riding with load; with cold tires
Tire pressure, rear	42.1 psi (2.9 bar), One-up and two-up riding with load; with cold tires

Electrical system

Electrical rating of onboard sockets	max 10 A, all slots in total
--------------------------------------	------------------------------

Battery

Battery design	Absorbent Glass Mat
Battery voltage	12 V
Battery capacity	16 Ah

Spark plugs

Spark plugs, manufacturer and designation	NGK LMAR8AI-8
-------------------------------------------	---------------

Light sources

Bulb for high-beam headlight	H7 12 V 55 W
Bulbs for low-beam headlight	Xenon D1S 12 V 35 W
Bulb for parking light	LED ring light
Bulb for taillight/brake light	LED
Bulbs for flashing turn indicators, front	LED
Bulbs for flashing turn indicators, rear	LED
Light source for license plate light	W5W 12 V 5 W

Fuses

Fuse carrier 1	40 A, Main fuse
Fuse carrier 2	7.5 A, Slot above: audio system 7.5 A, Slot below: anti-theft alarm system, central locking system

Anti-theft alarm system

Anti-theft alarm

Activation time	Approx. 30 s
Alarm duration	Approx. 26 s
Activation time between two alarms	15 s
Battery type	CR 1632 A

Remote control

Range of remote control	Approx. 32.8 ft (Approx. 10 m)
Signal frequency	20 kHz, wideband
Transmission frequency	433 MHz
Battery type and battery voltage (for remote key)	CR 2032

Dimensions

Motorcycle length	97.2 in (2470 mm)
Motorcycle height	51.2 in (1300 mm), over windshield, at DIN unladen weight
Motorcycle width	39.4 in (1000 mm)
Rider's seat height	29.5 in (750 mm), without rider, at DIN unladen weight
Rider's inside-leg arc, heel to heel	67.7 in (1720 mm), without rider, at DIN unladen weight

Weights

Vehicle curb weight	741 lbs (336 kg), DIN unladen weight, ready for road, 90% full tank of gas, without OE
Permissible gross weight	1235 lbs (560 kg)
Maximum payload	494 lbs (224 kg)

Performance data

Top speed	124 mph (200 km/h)
Top speed	
– with running board ^{OE}	max 112 mph (max 180 km/h), Maximum speed when riding with running boards

Service

Reporting safety defects	178
BMW Motorrad Service	179
BMW Motorrad Service History	179
BMW Motorrad Mobility Services	180
Maintenance procedures	180
Maintenance schedule	183
Maintenance confirmations	184
Service confirmations	198

Reporting safety defects

If you think that your motorcycle has a fault which may cause an accident, injury or death, you must inform the NHTSA (National Highway Traffic Safety Administration) immediately and BMW of North America, LLC.

If the NHTSA receives other similar complaints, it may open an investigation. If it finds that a safety defect exists in a group of vehicles, the NHTSA may order the manufacturer to perform a recall and remedy campaign. However, the NHTSA cannot become involved in individual problems between you, your authorized BMW Motorrad retailer, or BMW of North America, LLC.

You can contact the NHTSA by calling the Vehicle Safety Hotline on 1-888-327-4236 (Teletypewriter TTY for the hearing impaired: 1-800-424-9153) for free, by visiting the website at <http://www.safercar.gov> or by writing to Administrator, NHTSA, 400 Seventh Street, SW., Washington, DC 20590. Further information on vehicle safety is available at <http://www.safercar.gov>.

BMW Motorrad Service

With its worldwide retailer network, BMW Motorrad can attend to you and your motorcycle in over 100 countries around the globe. Authorized BMW Motorrad retailers have the technical information and expertise needed to conduct reliable service and repairs covering every aspect of your BMW.

You will find the nearest authorized BMW Motorrad retailer to you at our website:

bmw-motorrad.com

WARNING

Improperly performed maintenance and repair work

Accident hazard caused by subsequent damage

- BMW Motorrad recommends having corresponding work on the motorcycle carried out

by a specialized workshop, preferably by an authorized BMW Motorrad retailer. ◀

To ensure that your BMW consistently remains in optimal condition BMW Motorrad urges you to observe the recommended service intervals.

Have all maintenance and repair work confirmed in the "Service" chapter in this manual. Documentation confirming regular maintenance is essential for generous treatment of claims submitted after the warranty period has expired (goodwill).

You can obtain information on the contents of the BMW Services from your BMW Motorrad retailer.

BMW Motorrad Service History

Entries

Maintenance work that has been performed is recorded in the diagnostics and information system. Like a Service Booklet, these entries provide proof of regular maintenance.

If an entry is made in the vehicle's electronic Service Manual, service-related data is stored on the central IT systems of BMW AG in Munich, Germany.

When there is a change in vehicle owner, the data entered in the electronic Service History can also be viewed by the new vehicle owner. A BMW Motorrad retailer or specialist workshop can view the data entered in the electronic Service Manual.

Objection

At the BMW Motorrad retailer or specialist workshop, the vehicle owner can object to the entry of data in the electronic Service Manual with the related storage of data in the vehicle and the transfer of data to the vehicle manufacturer during his time as the vehicle owner. In this case, no entry is made in the vehicle's electronic Service Manual.

BMW Motorrad Mobility Services

The BMW Motorrad Mobility Services furnish you and your new BMW motorcycle with extra security by offering a wide array of assistance services in the event of a breakdown (BMW Roadside Assistance, breakdown assistance, vehicle recovery and retrieval, etc.).

Contact your authorized BMW Motorrad retailer for

additional information on available mobility-maintenance services.

Maintenance procedures

BMW Pre-Delivery Check

The BMW pre-delivery check is carried out by your authorized BMW Motorrad retailer before it turns over the vehicle to you.

BMW Running-in Check

The BMW running-in check must be carried out between 300 mls (500 km) and 750 mls (1200 km).

BMW Service

BMW Service is carried out once a year. The scope of the services performed may be dependent on the motorcycle owner and the mileage driven. Your BMW Motorrad retailer confirms that the service has been per-

formed and enters the date for the next service.

For riders who drive long distances annually, it may be necessary to come in for service before the entered date. In this case a corresponding maximum odometer reading will also be entered in the confirmation of service. If this odometer reading is reached before the next service date, service must be performed sooner.

The service information on the multifunction display reminds you of the next service date, which is approx. one month or 621 miles (1000 km) before reaching the input values.

More information on the topic of service is available at:

bmw-motorrad.com/service

The required scope of maintenance work for your motorcycle can be found in the following maintenance schedule:

Maintenance schedule

- 1 BMW Running-in check (including oil change)
- 2 BMW Service Standard Scope
- 3 Engine oil change with filter
- 4 Replace air cleaner insert
- 5 Check valve clearance
- 6 Replace all spark plugs
- 7 Check bearing for deflection at rear wheel swinging arm
- 8 Oil change in the rear bevel gears
- 9 Change brake fluid in entire system
 - a annually or every 6000 miles (10000 km) (whichever comes first)
 - b annually or every 12000 miles (20000 km) (whichever comes first)

c for the first time after one year, then every two years

Maintenance confirmations

BMW Service standard scope

The repair procedures belonging to the BMW Service standard package are listed below. The actual maintenance work applicable for your vehicle may differ.

- Performing the vehicle test using the BMW Motorrad diagnosis system
- Draining the oil condensate hose
- Visually inspect the brake lines, brake hoses and connections
- Checking front brake pads and brake disks for wear
- Checking brake fluid level of the front wheel brake
- Checking rear brake pads and brake disk for wear
- Checking brake fluid level in rear wheel brake
- Checking the clutch system
- Checking coolant level
- Checking the tire pressure and tread depth
- Checking side stand for ease of movement
- Checking the center stand for ease of movement
- Checking the lighting and signal system
- Functional check for engine starting suppression
- Final inspection and check for road safety
- Set service due date and remaining distance before next service using the BMW Motorrad diagnosis system
- Checking charging state of battery
- Confirm the BMW service in the vehicle literature

BMW pre-delivery check

performed

on _____

Stamp, signature

BMW Running-in Check

performed

on _____

at km _____

Next service

latest

on _____

or, if reached earlier

at km _____

Stamp, signature

BMW Service

performed

on _____

at km _____

Next service

latest

on _____

or, if reached earlier

at km _____

Work performed

BMW Service

Engine oil change with filter

Replacing air cleaner element

Checking valve clearance

Replacing all spark plugs

Check bearing for deflection at rear

wheel swinging arm

Oil change in rear bevel gears

Changing brake fluid in entire system

Yes

No

Information

Stamp, signature

BMW Service

performed

on _____

at km _____

Next service

latest

on _____

or, if reached earlier

at km _____

Work performed

BMW Service

Engine oil change with filter

Replacing air cleaner element

Checking valve clearance

Replacing all spark plugs

Check bearing for deflection at rear

wheel swinging arm

Oil change in rear bevel gears

Changing brake fluid in entire system

Yes

No

Information

Stamp, signature

BMW Service

performed

on _____

at km _____

Next service

latest

on _____

or, if reached earlier

at km _____

Work performed

BMW Service

Yes

No

Engine oil change with filter

Replacing air cleaner element

Checking valve clearance

Replacing all spark plugs

Check bearing for deflection at rear
wheel swinging arm

Oil change in rear bevel gears

Changing brake fluid in entire system

Information

Stamp, signature

BMW Service

performed

on _____

at km _____

Next service

latest

on _____

or, if reached earlier

at km _____

Work performed

BMW Service

Engine oil change with filter

Replacing air cleaner element

Checking valve clearance

Replacing all spark plugs

Check bearing for deflection at rear

wheel swinging arm

Oil change in rear bevel gears

Changing brake fluid in entire system

Yes

No

Information

Stamp, signature

BMW Service

performed

on _____

at km _____

Next service

latest

on _____

or, if reached earlier

at km _____

Work performed

BMW Service

Engine oil change with filter

Replacing air cleaner element

Checking valve clearance

Replacing all spark plugs

Check bearing for deflection at rear

wheel swinging arm

Oil change in rear bevel gears

Changing brake fluid in entire system

Yes

No

Information

Stamp, signature

BMW Service

performed

on _____

at km _____

Next service

latest

on _____

or, if reached earlier

at km _____

Work performed

BMW Service

Engine oil change with filter

Replacing air cleaner element

Checking valve clearance

Replacing all spark plugs

Check bearing for deflection at rear

wheel swinging arm

Oil change in rear bevel gears

Changing brake fluid in entire system

Yes

No

Information

Stamp, signature

BMW Service

performed

on _____

at km _____

Next service

latest

on _____

or, if reached earlier

at km _____

Work performed

BMW Service

Engine oil change with filter

Replacing air cleaner element

Checking valve clearance

Replacing all spark plugs

Check bearing for deflection at rear

wheel swinging arm

Oil change in rear bevel gears

Changing brake fluid in entire system

Yes

No

Information

Stamp, signature

BMW Service

performed

on _____

at km _____

Next service

latest

on _____

or, if reached earlier

at km _____

Work performed

BMW Service

Engine oil change with filter

Replacing air cleaner element

Checking valve clearance

Replacing all spark plugs

Check bearing for deflection at rear

wheel swinging arm

Oil change in rear bevel gears

Changing brake fluid in entire system

Yes No

Information

Stamp, signature

BMW Service

performed

on _____

at km _____

Next service

latest

on _____

or, if reached earlier

at km _____

Work performed

BMW Service

Engine oil change with filter

Replacing air cleaner element

Checking valve clearance

Replacing all spark plugs

Check bearing for deflection at rear

wheel swinging arm

Oil change in rear bevel gears

Changing brake fluid in entire system

Yes

No

Information

Stamp, signature

BMW Service

performed

on _____

at km _____

Next service

latest

on _____

or, if reached earlier

at km _____

Work performed

BMW Service

Engine oil change with filter

Replacing air cleaner element

Checking valve clearance

Replacing all spark plugs

Check bearing for deflection at rear

wheel swinging arm

Oil change in rear bevel gears

Changing brake fluid in entire system

Yes

No

Information

Stamp, signature

BMW Service

performed

on _____

at km _____

Next service

latest

on _____

or, if reached earlier

at km _____

Work performed

BMW Service

Engine oil change with filter

Replacing air cleaner element

Checking valve clearance

Replacing all spark plugs

Check bearing for deflection at rear

wheel swinging arm

Oil change in rear bevel gears

Changing brake fluid in entire system

Yes

No

Information

Stamp, signature

BMW Service

performed

on _____

at km _____

Next service

latest

on _____

or, if reached earlier

at km _____

Work performed

BMW Service

Engine oil change with filter

Replacing air cleaner element

Checking valve clearance

Replacing all spark plugs

Check bearing for deflection at rear

wheel swinging arm

Oil change in rear bevel gears

Changing brake fluid in entire system

Yes

No

Information

Stamp, signature

Appendix

Certificate for Electronic Immobilizer	202
Certificate for Remote Key.....	204
Certificate for Keyless Ride	208
Certificate for Tire Pressure Control	210

FCC Approval

Ring aerial in the ignition switch



To verify the authorization of the ignition key, the electronic immobilizer exchanges information with the ignition key via the ring aerial.

This device complies with Part 15 of the FCC rules. Operation is subject to the following two conditions:

- (1) This device may not cause harmful interference, and
- (2) this device must accept any interference received, including interference that may cause undesired operation.



Any changes or modifications not expressly approved by the party responsible for compliance could void the user's authority to operate the equipment. ◀

Approbation de la FCC

Antenne annulaire présente dans le commutateur d'allumage



Pour vérifier l'autorisation de la clé de contact, le système d'immobilisation électronique échange des

informations avec la clé de contact via l'antenne annulaire.

Le présent dispositif est conforme à la partie 15 des règles de la FCC. Son utilisation est soumise aux deux conditions suivantes :

- (1) Le dispositif ne doit pas produire d'interférences nuisibles, et
- (2) le dispositif doit pouvoir accepter toutes les interférences extérieures, y compris celles qui pourraient provoquer une activation inopportune.



Toute modification qui n'aurait pas été approuvée expressément par l'organisme responsable de l'homologation peut annuler l'autorisation accordée à l'utilisateur pour utiliser le dispositif. ◀

Certifications

Remote Control for central locking system



Česky

Meta System S.p.A. tímto prohlašuje, že tento PF240009 je ve shodě se základními požadavky a dalšími příslušnými ustanoveními směrnice 1999/5/ES.

Dansk

Undertegnede Meta System S.p.A. erklærer herved, at følgende udstyr PF240009 overholder de væsentlige krav og øvrige relevante krav i direktiv 1999/5/EF.

Deutsch

Hiermit erklärt Meta System S.p.A., dass sich das Gerät PF240009 in Übereinstimmung mit den grundlegenden Anforderungen und den übrigen einschlägigen Bestimmungen der Richtlinie 1999/5/EG befindet.

Eesti

Käesolevaga kinnitab Meta System S.p.A. seadme PF240009 vastavust direktiivi 1999/5/EÜ põhinõuetele ja nimetatud direktiivist tulenevatele teistele asjakohastele sätetele.

English

Hereby, Meta System S.p.A., declares that this PF240009 is in compliance with the essential requirements and other relevant provisions of Directive 1999/5/EC.

Español

Por medio de la presente Meta System S.p.A. declara que el PF240009 cumple con los requisitos esenciales y cualesquiera otras disposiciones aplicables o exigibles de la Directiva 1999/5/CE.

Certifications

Ελληνική

ΜΕ ΤΗΝ ΠΑΡΟΥΣΑ Meta System S.p.A. ΔΗΛΩΝΕΙ ΟΤΙ PF240009 ΣΥΜΜΟΡΦΩΝΕΤΑΙ ΠΡΟΣ ΤΙΣ ΟΥΣΙΩΔΕΙΣ ΑΠΑΙΤΗΣΕΙΣ ΚΑΙ ΤΙΣ ΛΟΙΠΕΣ ΣΧΕΤΙΚΕΣ ΔΙΑΤΑΞΕΙΣ ΤΗΣ ΟΔΗΓΙΑΣ 1999/5/ΕΚ.

Français

Par la présente Meta System S.p.A. déclare que l'appareil PF240009 est conforme aux exigences essentielles et aux autres dispositions pertinentes de la directive 1999/5/CE.

Italiano

Con la presente Meta System S.p.A. dichiara che questo PF240009 è conforme ai requisiti essenziali ed alle altre disposizioni pertinenti stabilite dalla direttiva 1999/5/CE.

Latviski

Ar šo Meta System S.p.A. deklarē, ka PF240009 atbilst Direktīvas 1999/5/ΕΚ būtiskajām prasībām un citiem ar to saistītajiem noteikumiem.

Lietuvių

Šiuo Meta System S.p.A. deklaruoja, kad šis PF240009 atitinka esminius reikalavimus ir kitas 1999/5/EB Direktyvos nuostatas.

Nederlands

Hierbij verklaart Meta System S.p.A. dat het toestel PF240009 in overeenstemming is met de essentiële eisen en de andere relevante bepalingen van richtlijn 1999/5/EG.

Malti

Hawnhekk, Meta System S.p.A., jiddikjara li dan PF240009 jikkonforma mal-ħtiġijiet essenzjali u ma provvedimenti oħrajn rilevanti li hemm fid-Dirrettiva 1999/5/EC.

Magyar

Alulírott, Meta System S.p.A. nyilatkozom, hogy a PF240009 megfelel a vonatkozó alapvető követelményeknek és az 1999/5/EC irányelv egyéb előírásainak.

Polski

Niniejszym Meta System S.p.A. oświadcza, że PF240009 jest zgodny z zasadniczymi wymogami oraz pozostałymi stosownymi postanowieniami Dyrektywy 1999/5/EC.

Português

Meta System S.p.A. declara que este PF240009 está conforme com os requisitos essenciais e outras disposições da Directiva 1999/5/CE.

Certifications

Slovensko

Meta System S.p.A. izjavlja, da je ta PF240009 v skladu z bistvenimi zahtevami in ostalimi relevantnimi določili direktive 1999/5/ES.

Slovensky

Meta System S.p.A. týmto vyhlasuje, že PF240009 spĺňa základné požiadavky a všetky príslušné ustanovenia Smernice 1999/5/ES.

Suomi

Meta System S.p.A. vakuuttaa täten että PF240009 tyypinen laite on direktiivin 1999/5/EY oleellisten vaatimusten ja sitä koskevien direktiivin muiden ehtojen mukainen.

Svenska

Härmed intygar Meta System S.p.A. att denna PF240009 står i överensstämmelse med de väsentliga egenskapskrav och övriga relevanta bestämmelser som framgår av direktiv 1999/5/EG.

Íslenska

Hér með lýsir Meta System S.p.A. yfir því að PF240009 er í samræmi við grunnkröfur og aðrar kröfur, sem gerðar eru í tilskipun 1999/5/EC.

Norsk

Meta System S.p.A. erklærer herved at utstyret PF240009 er i samsvar med de grunnleggende krav og øvrige relevante krav i direktiv 1999/5/EF.

USA, Canada

Product name: TX BMW MR FCC ID: P3O98400 IC:4429A - TXBMWMR

This device complies with Part 15 of the FCC rules. Operation is subject to the following two conditions:

- (1) This device may not cause harmful interference, and
- (2) this device must accept any interference received, including interference that may cause undesired operation.



Any changes or modifications not expressly approved by the party responsible for compliance could void the user's authority to operate the equipment.

Declaration Of Conformity

R&TTE Declaration Of Conformity (DoC)

CE0470

We:

Meta System S.p.A.

with the address:

Via Majakovskij 10 b/c/d/e
42124 Reggio Emilia -Italy

Declare

Under own responsibility that the product:

TX BMW MR

To which this declaration relates is in conformity with the essential requirements and other relevant requirements of the R&TTE Directive (1999/5/EC).

This product is in conformity with the following standards:

Health & Safety (art.3.1)

EN 60950-1

EMC (art.3.2)

ETSI EN 301 489-1/-3

Spectrum

ETSI EN 300 220 - 2

Human exposure

EN 62311

According to Directive 1999/5/CE

Reggio Emilia , 14/07/2010

Technical Director
Lasagni Cesare



Certifications

BMW Keyless Ride ID Device



USA, Canada

Product name: BMW Keyless Ride ID Device
FCC ID: YGOHUF5750
IC: 4008C-HUF5750

Canada:

Operation is subject to the following two conditions:

- (1) This device may not cause harmful interference, and
- (2) this device must accept any interference received, including interference that may cause undesired operation.

USA:

This device complies with Part 15 of the FCC rules. Operation is subject to the following two conditions:

- (1) This device may not cause harmful interference, and
- (2) this device must accept any interference received, including interference that may cause undesired operation.



Any changes or modifications not expressly approved by the party responsible for compliance could void the user's authority to operate the equipment.

Declaration Of Conformity

We declare under our responsibility that the product

BMW Keyless Ride ID Device (Model: HUF5750)

complies with the appropriate essential requirements of the article 3 of the R&TIE and the other relevant provisions, when used for its intended purpose. Applied Standards:

1. Health and safety requirements contained in article 3 (1) a)
 - EN 60950-1:2006+A11:2009+A1:2010+A12:2011; Information technology equipment- Safety
2. Protection requirements with respect to electromagnetic compatibility article 3 (1) b)
 - EN 301 489-1 (V1 .9.2, 09/2011), Electromagnetic compatibility and radio spectrum matters (ERM); Electromagnetic compatibility (EMC) standard for radio equipment and services; Part 1: Common technical requirements
 - EN 301 489-3 (V1.4.1, 08/2002) Electromagnetic compatibility and radio spectrum matters (ERM); Electromagnetic compatibility (EMC) standard for radio equipment and services; Part 3: Specific conditions for short range devices (SRD) operating on frequencies between 9 kHz and 40 GHz
3. Means of the efficient use of the radio frequency spectrum article 3 (2)
 - EN 300 220-1 & -2 (V2.4.1, 05/2012), electromagnetic compatibility and radio spectrum matters (ERM); Short range devices (SRD); Radio equipment to be used in the 25 MHz to 1000 MHz frequency range with power levels ranging up to 500 mW;
Part 1: Technical characteristics and test methods.
Part 2: Harmonized EN covering essential requirements under article 3.2 of the R&TIE directive

The product is labeled with the CE marking: **CE**

Velbert, October 15th, 2013

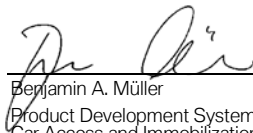

Benjamin A. Müller
Product Development Systems
Car Access and Immobilization – Electronics
Huf Hülbeck & Fürst GmbH & Co. KG
Steeger Straße 17, D-42551 Velbert

Certification Tire Pressure Control (TPC)

FCC ID: MRXBC54MA4
IC: 2546A-BC54MA4

FCC ID: MRXBC5A4
IC: 2546A-BC5A4

This device complies with Part 15 of the FCC Rules and with Industry Canada license-exempt RSS standard(s).

Operation is subject to the following two conditions:

- (1) This device may not cause harmful interference, and
- (2) This device must accept any interference received, including interference that may cause undesired operation.

Le présent appareil est conforme aux CNR d'Industrie Canada applicables aux appareils radio exempts de licence. L'exploitation est autorisée aux deux conditions suivantes:

- (1) l'appareil ne doit pas produire de brouillage, et
- (2) l'utilisateur de l'appareil doit accepter tout brouillage radioélectrique subi, même si le brouillage est susceptible d'en compromettre le fonctionnement.

WARNING: Changes or modifications not expressly approved by the party responsible for compliance could void the user's authority to operate the equipment. The term "IC:" before the radio certification number only signifies that Industry Canada technical specifications were met.

A

- Abbreviations and symbols, 6
- ABS
 - Indicator and warning lights, 44
 - Self-diagnosis, 95
 - Technology in detail, 108
- Accessories
 - General instructions, 150
- Anti-theft alarm system
 - Indicator light, 22
 - Operating, 68
 - Warning indicator, 43
- Auxiliary headlight
 - Operating, 59
- Average values
 - Resetting, 66

B

- Battery
 - Charge connected battery, 142
 - Charging disconnected battery, 143
 - Installing, 144
 - Maintenance instructions, 142
 - Position on motorcycle, 18

- Removing, 143
- Technical data, 171
- Warning for battery charge current, 42
- Warning for battery voltage low, 42

Brake fluid

- Check fluid level at rear, 126
- Check front fluid level, 125
- Front reservoir, 17
- Rear reservoir, 17

Brake pads

- Checking front, 124
- Checking rear, 124
- Running in, 97

Brake temperature

- Warning indicator, 47

Brakes

- ABS Pro in detail, 110
- ABS Pro, 99
- Adjusting handlebar lever, 90
- Checking operation, 123
- Safety information, 98
- Technical Data, 168

Breaking in, 97**Bulbs**

- High beam, 136
- Replace additional LED headlight, 140
- Replace LED tail light, 141
- Replacing the LED turn indicator, 141
- Technical data, 172
- Warning for bulb failure, 41

C**Care**

- Chrome, 159
- Paint preservation, 160

Case

- Operating, 151

Central locking

- Operating, 77
- Warning indicator for central locking, 44

Checklist, 94**Clock**

- Adjusting, 65

- Clutch
 - Adjusting handlebar lever, 89
 - Checking operation, 127
 - Technical Data, 166
- Coolant
 - Checking level, 127
 - Fluid level indicator, 17
 - Overtemperature warning indicator, 36
- Cruise-control system
 - Control, 19
 - Operating, 74
- D**
- Damping
 - Adjusting, 72
- Date
 - Adjusting, 65
- D-ESA
 - Control, 19
 - Operating, 72
 - Technology in detail, 113
- Diagnostic connector
 - fasten, 146
 - Loosen, 146
- Dimensions
 - Technical Data, 174
- DTC
 - Control, 19
 - Operating, 72
 - Self-diagnosis, 96
 - Technology in detail, 111
 - Warning indicator, 44
- DWA
 - Technical Data, 173
- E**
- Electrical system
 - Technical Data, 171
- Emergency on/off switch (kill switch), 21
 - Operating, 56
- Engine
 - Starting, 94
 - Technical Data, 165
 - Warning light for electronic engine management, 36
- Engine oil
 - Check fill level, 122
 - Filling location, 17
 - Oil dipstick, 17
 - Oil level indicator, 37
 - Technical Data, 164
 - Topping up, 123
 - Warning for engine oil level, 38
- Equipment, 7
- F**
- Frame
 - Technical Data, 167
- Front wheel stand
 - Mounting, 120
- Fuel
 - Filling location, 15
 - Fuel specifications, 100
 - Refueling, 101
 - refueling with Keyless Ride, 102, 103
 - Technical Data, 164
- Fuel reserve
 - Range, 45
 - Warning indicator, 46
- Fuses
 - Position on motorcycle, 18
 - Replacing, 145
 - Technical Data, 171

G
Gearshift assistant, 116
 Technology in detail, 116
Ground lighting
 Operating, 60

H
Hazard warning flashers
 Control, 19
 Operating, 60
Headlight
 Headlight range adjustment, 15
 Set right-/left-hand traffic, 59
 Warning indicator for LHD/RHD traffic, 41
 Warning indicator for unknown position, 40
Heated handlebar grips
 Operating, 81
Hill Start Control Pro, 117
 cannot be activated, 47
 Indicator and warning lights, 46
 Operating, 76
 Technology in detail, 117
Horn, 19

I
Ignition
 Switching off, 51
 Switching on, 50
Immobilizer
 Emergency key, 51, 54
 Warning indicator, 35
Indicator lights, 22
 DTC, 44
 Overview, 24
Instrument cluster
 Ambient light photosensor, 22
 Overview, 22

J
Jump-starting, 141

K
Keyless Ride
 Battery of the key fob transmitter is empty or the key fob transmitter is lost, 54
 EWS Electronic immobilizer, 54
 Locking handlebars, 52
 Switch off ignition, 53
 Switching on ignition, 52

 Unlocking fuel filler cap, 102, 103
 Warning indicator, 35, 36
Keys, 50, 51

L
Lights
 Control, 19
 Headlight low beam, 58
 Operating headlight flasher, 58
 Operating high-beam headlight, 58
 Operating parking lights, 58
 Parking lights, 58
Luggage
 Loading information, 92

M
Maintenance
 General instructions, 120
 Maintenance schedule, 183
Maintenance confirmations, 184
Maintenance intervals, 180
Mirrors
 Adjusting, 88
Mobility Services, 180

- Motorcycle
 - Care, 157
 - Cleaning, 157
 - Parking, 100
 - Returning to use, 160
 - Storage, 160
 - Tying down, 104
- Multifunction display, 22
 - Control, 19
 - Meaning of symbols, 25
 - Operating, 62
 - Overview, 27
 - Settings, 65
- Multifunction switch
 - General view, left, 19
 - General view, right, 21

N

- Navigation devices
 - Installing, 152
 - Operating, 154
 - Removing, 153
- Notice concerning current status, 7

O

- Odometer
 - Operating, 67
- Onboard computer
 - Operating, 66
- Onboard power socket
 - Information on use, 150
 - Position on motorcycle, 17
- Onboard tool kit
 - Contents, 120
 - Position on motorcycle, 18
- Outside temperature
 - Display, 35
 - Outside temperature warning, 35
- Overview of warning indicators, 29
- Overviews
 - Indicator and warning lights, 24
 - Instrument cluster, 22
 - Left side of motorcycle, 15
 - Left-side multifunction switch, 19
 - Multifunction display, 27
 - Right side of motorcycle, 17

- Right-hand multifunction switch, 21
- Underneath seat, 18

P

- Pre-Ride-Check, 95

R

- RDC
 - Display, 38
 - Rim sticker, 130
 - Technology in detail, 115
 - Warning indicators, 38
- Rear-wheel drive
 - Technical Data, 167
- Refueling, 101
 - Fuel specifications, 100
 - with Keyless Ride, 102, 103
- Remote control
 - logging on, 78
 - Replacing battery, 80
 - Replacing the battery, 55
 - synchronize, 79
- Reverser, 56
 - Control, 19

- Rider's Manual (US Model)
 - Position on motorcycle, 18
- Rider's seat
 - Height adjustment, 18
- Riding mode
 - Adjusting, 73
 - Technology in detail, 113

S

- Safety instructions
 - On braking, 98
 - On riding, 92
- Seat
 - Installing, 83
 - Release, 15
 - Removing, 83
- Seat heating
 - Operating, 82
- Service, 179
 - Electronic Service Manual, 179
 - Reporting safety defects, 178
 - Warning indicator, 48
- Service display, 47

- Spark plugs
 - Technical Data, 171
 - Speedometer, 22
 - Spring preload
 - Adjusting, 72
 - Starting, 94
 - Control, 21
 - Steering lock
 - Locking, 50
 - Storage compartment
 - Operating, 84
 - Position on motorcycle, 15, 17
 - Suspension
 - Technical Data, 168
 - Switching off, 100
 - Symbols
 - Meaning, 25
- ## T
- Tachometer, 22
 - Technical data
 - Anti-theft alarm system, 173
 - Battery, 171
 - Brakes, 168
 - Bulbs, 172

- Clutch, 166
 - Dimensions, 174
 - Electrical system, 171
 - Engine, 165
 - Engine oil, 164
 - Frame, 167
 - Fuel, 164
 - General notes, 7
 - Rear-wheel drive, 167
 - Spark plugs, 171
 - Standards, 7
 - Suspension, 168
 - Transmission, 166
 - Weights, 174
 - Wheels and tires, 169
- ## Tires
- Checking tire pressures, 128
 - Checking tire tread depth, 129
 - Checking tread depth, 129
 - Inflation pressure table, 18
 - Inflation pressures, 171
 - Recommendation, 129
 - Running in, 97

- Technical Data, 169
- Torques, 163
- Transmission
 - Technical Data, 166
- Troubleshooting chart, 162
- Turn indicators
 - Control, 19
 - Operating, 61
- Type plate
 - Position on motorcycle, 17

V

- Vehicle identification number
 - Position on motorcycle, 17

W

- Warning lamps, 22
 - ABS, 44
 - Anti-theft alarm, 43
 - Battery charge current, 42
 - Brake temperature, 47
 - Bulb defective, 41
 - Central locking, 44
 - Coolant temperature, 36
 - Display, 28

- Electronic engine management, 36
- Electronic immobilizer, 35
- Engine oil level, 38
- Fuel reserve, 46
- Headlight for LHD/RHD traffic, 41
- Headlight in unknown position, 40
- Hill Start Control Pro, 46, 47
- Outside temperature warning, 35
- Overview, 24
- Service, 48
- Tire Pressure Monitor, 38
- Undervoltage, 42
- Weights
 - Load capacity table, 18
 - Technical Data, 174
- Wheels
 - Check wheel rims, 129
 - Checking rims, 129
 - Installing front wheel, 132
 - Installing rear wheel, 135
 - Removing front wheel, 130

- Removing rear wheel, 134
- Size change, 130
- Technical Data, 169
- Wind deflection wing
 - Adjusting, 89
- Windshield
 - Adjusting, 88
 - Control, 19

The descriptions and illustrations in this manual may vary from your own motorcycle's actual equipment, depending upon its equipment level and accessories as well as your specific national version. No claims stemming from these differences can be recognized.

Dimensions, weights, fuel consumption and performance data are quoted to the customary tolerances.

The right to modify designs, equipment and accessories is reserved.

Errors and omissions excepted.

© 2018 Bayerische Motoren Werke Aktiengesellschaft
80788 Munich, Germany
Reprints and duplication of this work, in whole or part, are prohibited without the express written approval of BMW Motorrad, Aftersales.

Original Rider's Manual, printed in Germany.

WARNING

Harmful substances

Operating, servicing and maintaining a passenger vehicle or off-road vehicle can expose you to chemicals including engine exhaust, carbon monoxide, phthalates and lead, which are known to the State of California to be carcinogenic or detrimental to childbirth or reproduction.

- To minimize exposure, avoid breathing exhaust, do not idle the engine except as necessary, service your vehicle in a well-ventilated area and wear gloves or wash your hands frequently when servicing your vehicle.
- For more information visit: www.P65Warnings.ca.gov/passenger-vehicle ◀

