



**BMW
MOTORRAD**

RIDER'S MANUAL (US MODEL)

F 900 GS



MAKE LIFE A RIDE

Vehicle data

Model

Vehicle identification number

Color number

First registration

License plate

Retailer data

Contact in Service

Ms./Mr.

Phone number

Retailer's address/Phone (company stamp)

YOUR BMW.

We are pleased that you have chosen a BMW Motorrad vehicle and welcome you to the family of BMW riders. Familiarize yourself with your new vehicle so that you can ride safely and confidently in all traffic situations.

About these operating instructions

Read this rider's manual before starting your new BMW. It contains important notes about operating the vehicle that will enable you to make full use of the technical assets of your BMW.

You will also obtain preventive maintenance and care instructions, which are beneficial to operating and road safety and help retain the value of your vehicle as much as possible.

If you should decide to sell your BMW one day, please remember to hand over this rider's manual as well. It is an important part of your vehicle.

We wish you many miles of safe and enjoyable riding with your BMW

BMW Motorrad.

01 GENERAL INSTRUCTIONS	2	Tachometer	31
Quick & easy reference	4	Upshift recommendation	32
Abbreviations and symbols	4	Indicator lights	32
Equipment	5		
Technical data	5	<hr/> 04 INSTRUMENT CLUSTER	58
Currentness of this manual	6	Warnings	60
Additional sources of information	6	Operating elements	60
Certificates and operating permits	6	My Vehicle	63
Data memory	6	Settings	64
Intelligent assist system	11	Bluetooth pairing	66
		Operating focus	68
		Navigation	69
		Media	71
		Telephone	72
		Software version	72
		License information	72
<hr/> 02 OVERVIEWS	16		
Overall view, left side	18	<hr/> 05 OPERATION	74
Overall view, right side	19	Ignition switch/steering lock	76
Underneath the seat	20	Ignition with Keyless Ride	77
Multifunction switch, left	21	Electronic immobilizer EWS	81
Multifunction switch, right	22	Emergency-off switch	81
Multifunction switch, right	23	Intelligent emergency call	82
Instrument cluster	24	Lighting	84
		Traction control (DTC)	87
<hr/> 03 DISPLAYS	26	Riding mode	88
Indicator and warning lights	28	PRO riding mode	91
Pure Ride view	29	Cruise control	92
Menu view	30		

Anti-theft alarm system (DWA)	94
Tire Pressure Monitor (TPM)	97
Heated grips	97
Seat	98

06 SETTING 100

Mirrors	102
Headlights	102
Clutch	103
Brakes	103
Shifting	104
Spring preload	104
Damping	107

07 RIDING 112

Safety instructions	114
Regular check	118
Starting	119
Breaking in	122
Shifting	123
Off-road use	124
Brakes	125
Parking the motorcycle	127
Refueling	128
Fastening motorcycle in place for transportation	133

08 TECHNOLOGY IN DETAIL 134

General notes	136
Antilock braking system (ABS)	136
Traction control (DTC)	139
Engine drag torque control	141
Riding mode	142
Dynamic Brake Control	144
Tire Pressure Monitor (RDC)	144
Gear Shift Assistant	146

09 MAINTENANCE 148

General notes	150
Onboard vehicle tool kit	151
Front wheel stand	151
Rear-wheel stand	152
Engine oil	152
Brake system	154
Clutch	159
Coolant	160
Tires	162
Rims	163
Wheels	163
Drive chain	175
Air filter	179
Light sources	181
Trim panel components	181
Jump-starting	182
Battery	183

Fuses	188	Electrical system	222
Diagnostic connector	189	Dimensions	223
<hr/>		Weights	224
10 ACCESSORIES	192	Performance data	224
<hr/>		<hr/>	
General notes	194	13 SERVICE	226
Sockets	194	Reporting safety defects	228
USB charging socket	195	Recycling	229
Case	196	BMW Motorrad	
Navigation system	198	Service	229
<hr/>		BMW Motorrad	
11 CARE	202	service history	230
Care products	204	BMW Motorrad mo-	
Washing the vehicle	204	bility services	230
Cleaning sensitive		Maintenance work	230
motorcycle parts	205	Maintenance sched-	
Care of paintwork	206	ule	232
Paint preservation	207	BMW Motorrad	
Storing the motorcy-		break-in service	233
cle	207	Maintenance confir-	
Putting the motorcy-		mations	234
cle into operation	207	Service confirmations	246
<hr/>		<hr/>	
12 TECHNICAL DATA	210	APPENDIX	248
Troubleshooting chart	212	Radio equipment TFT	
Threaded connections	214	instrument cluster	249
Fuel	216	Radio equipment	
Engine oil	217	tyre pressure control	
Engine	217	(RDC)	250
Clutch	218	Keyless Ride ECU	250
Transmission	218	Keyless Ride Key	251
Rear-wheel drive	219	Radio equipment	
Frame	219	electronic immo-	
Running gear	219	biliser	252
Brakes	220		
Wheels and tires	221		

**Radio equipment in-
telligent emergency
call** **253**

INDEX **256**

GENERAL INSTRUCTIONS

01

QUICK & EASY REFERENCE	4
ABBREVIATIONS AND SYMBOLS	4
EQUIPMENT	5
TECHNICAL DATA	5
CURRENTNESS OF THIS MANUAL	6
ADDITIONAL SOURCES OF INFORMATION	6
CERTIFICATES AND OPERATING PERMITS	6
DATA MEMORY	6
INTELLIGENT ASSIST SYSTEM	11

4 GENERAL INSTRUCTIONS

QUICK & EASY REFERENCE

This rider's manual has been designed to provide quick and efficient orientation. The quickest way for you to find information on specific topics is to consult the comprehensive index at the end of the rider's manual. If you would like to start with a quick overview of your vehicle, this information has been provided in chapter 2. All preventive maintenance and repair procedures carried out on your motorcycle will be documented in the chapter "Service". Documentation of the maintenance work performed is a prerequisite for generous treatment of claims.

ABBREVIATIONS AND SYMBOLS



 **CAUTION** Hazard with low risk. Failure to avoid this hazard can result in minor or moderate injury.

 **WARNING** Hazard with moderate risk. Failure to avoid this hazard can result in death or serious injury.

 **DANGER** Hazard with high risk. Failure to avoid this hazard results in death or serious injury.

 **ATTENTION** Special instructions and precautionary measures. Non-compliance can cause damage to the vehicle or accessories and warranty claims may be denied as a result.

 Special information on operating and inspecting your motorcycle as well as maintenance and adjustment procedures.

- Instruction.
- » Result of a repair procedure.
-  Reference to a page with more detailed information.
- < Indicates the end of accessory or equipment-dependent information.
-  Tightening torque.
-  Technical data.
- NV National-market version.

OE	Optional equipment. BMW Motorrad optional equipment is already completely installed during motorcycle production.
OA	Optional accessories. BMW Motorrad optional accessories can be purchased and retrofitted at your authorized BMW Motorrad dealer.
ABS	Anti-Lock Brake System.
DTC	Dynamic Traction Control.
DWA	Anti-theft alarm.
EWS	Electronic immobilizer.
TPC	Tire Pressure Control (TPC).

EQUIPMENT

When you ordered your BMW Motorrad, you chose various custom equipment items. This rider's manual describes optional equipment (OE) and selected optional accessories (OA) offered by BMW. This explains why the manual may also contain descriptions of equipment which you have not

ordered. Please note, too, that your motorcycle might not be exactly as illustrated in this manual on account of country-specific differences.

If your motorcycle features equipment that is not described here, you can find these features described in a separate manual.

TECHNICAL DATA

All dimensions, weights and performance data contained in this rider's manual refer to the German Institute for Standardization i.e. DIN (Deutsches Institut für Normung e. V.) and comply with their tolerance specifications.

The technical data and specifications in this rider's manual serve as points of reference. The vehicle-specific data may vary, for instance due to the selected optional equipment, national-market version or country-specific measuring procedures. Detailed values can be obtained from the registration documents or requested from your authorized BMW Motorrad dealer or other qualified service partner or repair shop. The information on the vehicle documents always takes prece-

6 GENERAL INSTRUCTIONS

dence over the information in this rider's manual.

CURRENTNESS OF THIS MANUAL

The high safety and quality levels of BMW motorcycles are maintained by constant development work on design, equipment and accessories.

For this reason, some aspects of your vehicle may vary from the descriptions in this rider's manual. At the time of manufacturing of the motorcycle, the rider's manual is the most current source. Due to updates after the press date, there can be differences between the printed rider's manual and the online version.

Updated information is available at bmw-motorrad.com/service.

ADDITIONAL SOURCES OF INFORMATION

Authorized BMW Motorrad dealer

Your authorized BMW Motorrad dealer is always happy to answer any of your questions.

Internet

The rider's manual for your vehicle, the Owner's Manual and installation instructions for optional accessories and general BMW Motorrad information related to the technology or other features are available at bmw-motorrad.com/manuals.

CERTIFICATES AND OPERATING PERMITS

The certificates for the vehicle and the official operating permits for possible accessories are available at bmw-motorrad.com/certification.

DATA MEMORY

General information

Control units are installed in the vehicle. Control units process data received from vehicle sensors, self-generated data or data exchanged between control units, for example. Some control units are required for safe vehicle operation or provide riding assistance, such as rider assistance systems. Control units also make comfort and infotainment functions possible.

Information about the stored or exchanged data can be ob-

tained from the vehicle manufacturer, such as in the form of a separate booklet.

Personal references

Every vehicle is marked with a unique vehicle identification number. Depending on the country, the vehicle owner can be identified using the vehicle identification number and license plate and with the help of the relevant authorities. There are also other ways to trace data obtained from the vehicle back to the rider or vehicle owner, such as via the ConnectedDrive Account that was used.

Data privacy laws

In accordance with applicable data privacy laws, vehicle users have certain rights over the vehicle manufacturer or company that collects or processes personal data.

Vehicle users have the right to obtain comprehensive information without charge from the locations that store the vehicle user's personal data.

These locations may be:

- The vehicle manufacturer
- Qualified service partners
- Repair shops
- Service providers

Vehicle users may request information about the type of personal data that is stored, the purpose for which the data will be used and the source of the data. This information can only be obtained by a registered owner or a person with written proof authorizing use of the vehicle.

The right to information also includes information related to data transmitted to other companies or locations.

The vehicle manufacturer's website contains the appropriate privacy policy notices. The privacy policy notices contain information on the right to delete or correct data. The vehicle manufacturer also provides the manufacturer contact information and the contact information of the data security officer on the Internet.

The vehicle owner can have an authorized BMW Motorrad dealer or other qualified service partner or repair shop read out the data stored in the vehicle for a fee if required.

8 GENERAL INSTRUCTIONS

The vehicle data is read out via the vehicle's legally mandated diagnostic socket.

Operating data in the vehicle

Control units process data so that the vehicle can run.

Examples of this include:

- Status messages from the vehicle and its individual components, such as wheel speed, wheel centrifugal velocity and deceleration
- Ambient conditions, such as temperature

The data is processed only in the vehicle itself and is usually temporary. The data is not stored beyond the period in which the vehicle is operating. Electronic components such as control units contain components for storing technical information. This may be information about the vehicle's condition, component load, events or faults stored temporarily or permanently.

This information generally documents the condition of a component, module, system or the surrounding area; for example:

- Operating states of system components, such as fill levels and tire pressure
- Malfunctions and faults in key system components, such as lights and brakes
- Vehicle responses in specific riding situations, such as the activation of riding dynamics systems
- Information about events causing damage to the vehicle

The data is necessary for providing control unit functions. In addition, it is used by the vehicle manufacturer to detect and eliminate malfunctions as well as to optimize vehicle functions.

The majority of this data is temporary and is processed only within the vehicle itself. Only a small amount of event-driven data is stored in the event data recorder and fault memory.

When a vehicle is serviced, such as for repairs, servicing processes, warranty cases and quality assurance measures, this technical information can be read out from the vehicle together with the vehicle identification number.

The information can be read out by an authorized

BMW Motorrad dealer or other qualified service partner or repair shop. The vehicle's legally mandated diagnostic socket is used to read out the data.

The data is collected, processed and used by the respective service network locations. The data documents the vehicle's technical states and helps with fault finding, compliance with warranty obligations and quality improvements.

The manufacturer also has product monitoring obligations arising from product liability law. The vehicle manufacturer requires technical data from the vehicle in order to fulfill these obligations. The data from the vehicle can also be used to verify customer warranty and guarantee claims. The fault memory and event data recorder in the vehicle can be reset by an authorized BMW Motorrad dealer or other qualified service partner or repair shop as part of a repair or servicing.

Data input and data transfer in the vehicle

General information

Depending on the equipment, comfort settings and individualized settings in the vehicle can be saved and changed or reset at any time.

It is possible to introduce data into the vehicle entertainment and communication system via a smartphone, for instance.

Depending on the individual equipment, this includes:

- Multimedia data, such as music for playback
- Address book data for use in combination with a communication system or integrated navigation system
- Entered destinations
- Data about the use of Internet services. This data can be stored locally in the vehicle or is on a device connected to the vehicle, such as a smartphone, USB stick or MP3 player. If this data is saved in the vehicle, it can be deleted at any time.

This data is transmitted to third parties only upon personal request as part of the use of online services. The data transmitted depends on the selected

10 GENERAL INSTRUCTIONS

settings when using the services.

Incorporating mobile end devices

Depending on the equipment, mobile end devices connected to the vehicle, such as smartphones, are controlled using the vehicle's operating elements.

This enables audio and visual output from mobile end devices through the multimedia system. At the same time, certain information is transmitted to the mobile end device. This includes, for instance, position data and other general vehicle information, depending on the type of incorporation, and makes it possible to optimize the use of selected apps, such as those for navigation or audio playback.

The way the data is processed further is determined by the provider of the particular app used. The range of possible settings depends on the particular app and the operating system of the mobile end device.

Services

General information

If the vehicle has a mobile phone connection, this connection makes it possible to exchange data between the vehicle and other systems. The mobile phone connection is made possible through the vehicle's transmitter and receiver or via personally integrated mobile end devices such as smartphones. Online functions, as they are called, are used over this mobile phone connection. These include online services and apps provided by the vehicle manufacturer or other providers.

Vehicle manufacturer services

In the case of the vehicle manufacturer's online services, the particular functions are described at the appropriate location, such as in the rider's manual or on the manufacturer's website. The relevant legal information on data privacy is also provided there. Personal data may be used in order to provide online services. The data is exchanged over a secure connection, i.e. with the vehicle manufacturer's IT sys-

tems which are intended for this purpose.

Any collection, processing and use of personal data that goes beyond the provision of services take place only as permitted by law, on the basis of a contractual agreement or as a result of consent. It is also possible to have the entire data connection activated or deactivated. This is not the case for legally prescribed functions.

Services of other providers

When using the online services of other providers, these services are subject to the responsibility and the term of data protection and use of the respective provider. The vehicle manufacturer has no control over the content exchanged via these services. Information about the type, scope and purpose of collecting and using personal data as part of third-party services can be obtained from the particular service provider.

INTELLIGENT ASSIST SYSTEM

–with intelligent emergency call^{OE}

Principle

The intelligent assist system makes it possible to place manual or automatic emergency calls in the event of an accident, for example.

The emergency calls are answered by an emergency call center authorized by the vehicle manufacturer.

For information on how to operate the intelligent assist system and its features, see (▣▣▣▣▶ 82).

Legal basis

The processing of personal data by way of the intelligent assist system complies with the following regulations:

–Protection of personal data:
Directive 95/46/EC of the European Parliament and of the Council.

–Protection of personal data:
Directive 2002/58/EC of the European Parliament and of the Council.

The legal basis for the activation and operation of the intelligent assist system are the

12 GENERAL INSTRUCTIONS

signed ConnectedRide contract for this function, as well as the corresponding laws, regulations, and directives of the European Parliament and European Council.

The relevant regulations and directives govern the protection of individuals when processing personal data.

The processing of personal data by the intelligent assist system conforms to the European directive concerning personal data protection.

The intelligent assist system processes personal data only with the consent of the vehicle owner.

The intelligent assist system and other services with additional benefits may process personal data only with the express consent of the individual affected by the data processing, for example, the vehicle owner.

SIM card

The intelligent assist system is operated by way of mobile radio via the installed SIM card in the vehicle. The SIM card is permanently registered to the mobile phone network to enable a fast connection setup.

The data is sent to the vehicle manufacturer in the event of an emergency.

Quality improvement

The data transmitted in the event of an emergency call is also used by the vehicle manufacturer to improve the quality of products and services.

Geopositioning

The vehicle position can be determined exclusively by the mobile phone network provider based on their mobile phone cell towers. The network provider cannot link the vehicle identification number and phone number of the installed SIM card. Only the vehicle manufacturer can link the vehicle identification number and phone number of the installed SIM cards.

Emergency call log data

The emergency call log data is stored in the vehicle memory. The oldest log data is deleted regularly. The log data includes for example information about when and where an emergency call was initiated. The log data can be read out from the vehicle memory in exceptional cases. The log data is usually

read out only by court order and can only be read out when the relevant devices are connected directly to the vehicle.

Automatic emergency call

The system is designed so that an emergency call is triggered automatically in the event of an accident of a particular severity detected by sensors in the vehicle.

Transmitted information

In the event of an emergency call by the intelligent assist system, the same information is forwarded to the authorized emergency call center as is forwarded by the assist system eCall to the public emergency operations center.

Moreover, through the intelligent assist system, the following additional information is sent to one of the emergency call centers authorized by the vehicle manufacturer and forwarded to the public safety answering point if necessary:

- Accident data, such as the direction of impact detected by the vehicle sensors in order to facilitate planning of the deployment of emergency services.

- Contact information, such as the phone number of the installed SIM card and that of the rider, if available, in order to expedite contact with the individuals involved in the accident.

Data storage

The data related to a triggered emergency call is stored in the vehicle. The data contains information about the emergency call, such as the emergency call location and time.

Audio recordings of emergency calls are stored at the emergency call center.

Customer audio recordings are stored for 24 hours in case the details of the emergency call need to be analyzed. The audio recordings are then deleted. Emergency call center employee audio recordings are stored for 24 hours for quality assurance purposes.

Disclosure of personal data

The data processed as part of the intelligent emergency call is processed only for the purpose of providing the emergency call service. The vehicle manufacturer discloses information about the data that it processes or continues to store

14 GENERAL INSTRUCTIONS

if necessary as part of its legal obligation.

Regional limitation

For the installed Intelligent Emergency Call system to function properly, the respective national-market vehicle must support the current region.

For more information on regional limitations:

support.bmw-motorrad.com

OVERVIEWS

02

OVERALL VIEW, LEFT SIDE	18
OVERALL VIEW, RIGHT SIDE	19
UNDERNEATH THE SEAT	20
MULTIFUNCTION SWITCH, LEFT	21
MULTIFUNCTION SWITCH, RIGHT	22
MULTIFUNCTION SWITCH, RIGHT	23
INSTRUMENT CLUSTER	24

18 OVERVIEWS

OVERALL VIEW, LEFT SIDE



- 1 Socket (☞ 194)
- 2 USB charging interface (☞ 195)
- 3 Seat lock (☞ 98)
- 4 Passenger grab handle
- 5 Setting the damping (☞ 107)
- 6 Passenger footrest
- 7 Rider footrest
- 8 Oil filler opening and oil level dipstick (☞ 152)

OVERALL VIEW, RIGHT SIDE

- | | |
|---|--------------------------------|
| 1 Spring preload setting
(► 104) | 8 Passenger grab handle |
| 2 Brake fluid reservoir
for rear wheel brake
(► 158) | |
| 3 Brake fluid reservoir
for front wheel brake
(► 157) | |
| 4 Vehicle identification
number, nameplate (on
steering head) | |
| 5 Coolant level indicator
(behind the side trim pan-
el) (► 160) | |
| 6 Rider footrest | |
| 7 Passenger footrest | |

20 OVERVIEWS

UNDERNEATH THE SEAT

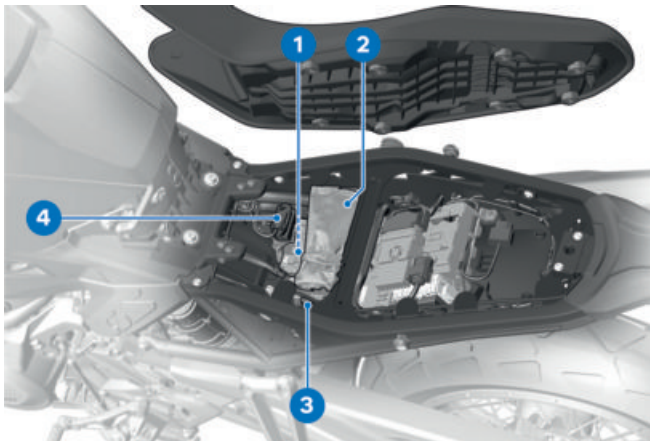

- 1 Battery (➡ 183)
- 2 Onboard vehicle tool kit (➡ 151)
- 3 Main fuse (➡ 188)
- 4 Diagnostic connector (➡ 189)

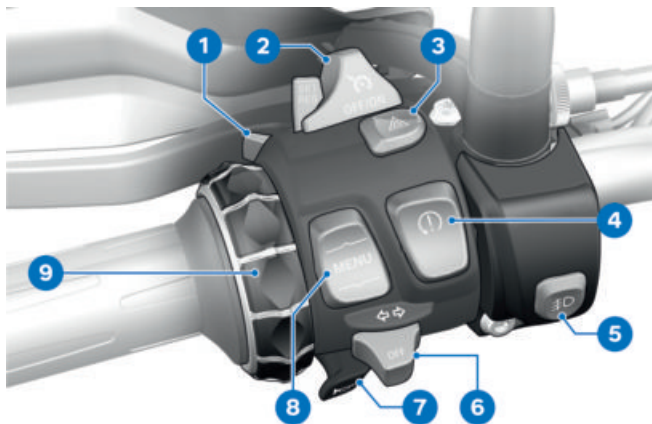
MULTIFUNCTION SWITCH, LEFT

- 1 High beams and headlight flasher (▮▮▮ 85)
- 2 Cruise control (▮▮▮ 92)
- 3 Hazard warning system (▮▮▮ 86)
- 4 DTC (▮▮▮ 87)
- 5 Auxiliary headlights (▮▮▮ 86)
- 6 Turn signals (▮▮▮ 86)
- 7 Horn
- 8 Rocker button MENU (▮▮▮ 61)
- 9 Multi-Controller (▮▮▮ 60)

22 OVERVIEWS

MULTIFUNCTION SWITCH, RIGHT

–with intelligent emergency call^{OE}

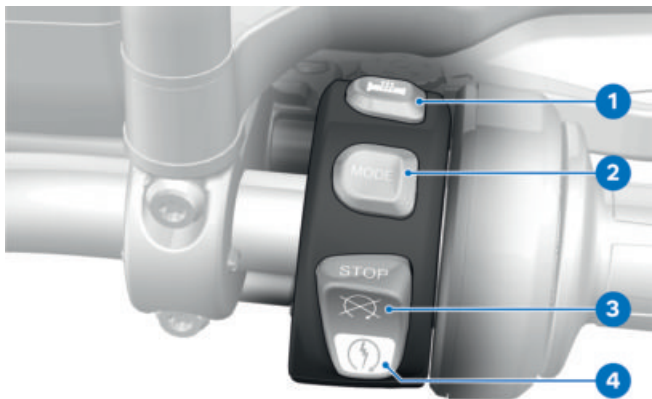

- 1 Operating heated grips
(⇒ 97)
- 2 Select riding mode
(⇒ 89)
- 3 Emergency-off switch
(⇒ 81)
- 4 Starter button (⇒ 119)
- 5 SOS button
Intelligent emergency call
(⇒ 82)

MULTIFUNCTION SWITCH, RIGHT

- 1** Operating heated grips
(⇒ 97)
- 2** Select riding mode
(⇒ 89)
- 3** Emergency-off switch
(⇒ 81)
- 4** Starter button (⇒ 119)

24 OVERVIEWS

INSTRUMENT CLUSTER



- 1 Indicator and warning lights (➡ 28)
- 2 Instrument cluster (➡ 29) (➡ 30)
- 3 DWA LED (➡ 95)
-with Keyless Ride^{OE}
Indicator light for radio-operated key (➡ 78)
- 4 Photodiode (for adjusting brightness of instrument lighting)

DISPLAYS

03

INDICATOR AND WARNING LIGHTS	28
PURE RIDE VIEW	29
MENU VIEW	30
TACHOMETER	31
UPSHIFT RECOMMENDATION	32
INDICATOR LIGHTS	32

28 DISPLAYS

INDICATOR AND WARNING LIGHTS

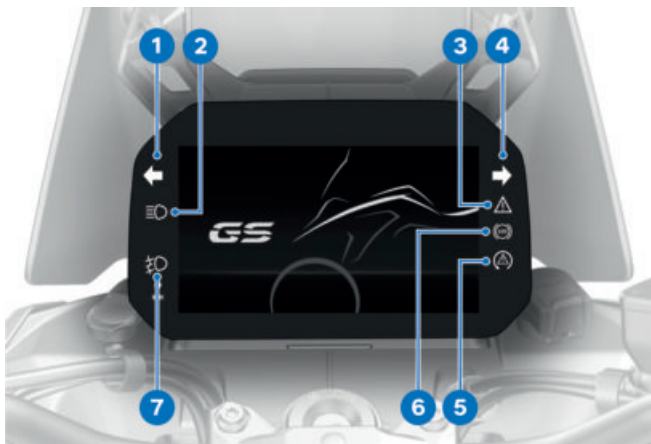

- 1 Turn signal, left (►► 86)
- 2 High beams (►► 85)
- 3 General warning light (►► 32)
- 4 Turn signal, right (►► 86)
- 5 DTC (►► 53)
- 6 ABS (►► 52)
- 7 -with LED additional headlight^{OA}
Auxiliary headlights.
(►► 86)

PURE RIDE VIEW

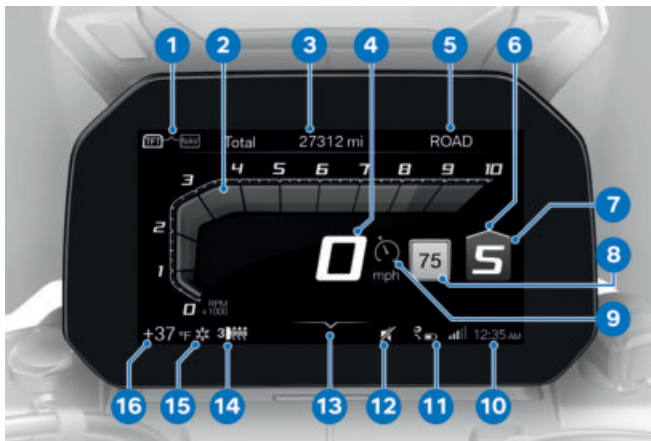

- | | |
|---|--|
| 1 Changing operating focus (►► 68) | 14 Heated grip settings (►► 97) |
| 2 Tachometer (►► 31) | 15 External temperature warning (►► 39) |
| 3 Status line (►► 64) | 16 Outside temperature |
| 4 Speedometer | |
| 5 Riding mode (►► 88) | |
| 6 Upshift recommendation (►► 32) | |
| 7 Gear display | |
| 8 Speed Limit Info (►► 71) | |
| 9 Cruise control (►► 92) | |
| 10 Clock (►► 66) | |
| 11 Connection status (►► 67) | |
| 12 Muting (►► 65) | |
| 13 Operating assistance | |

30 DISPLAYS

MENU VIEW

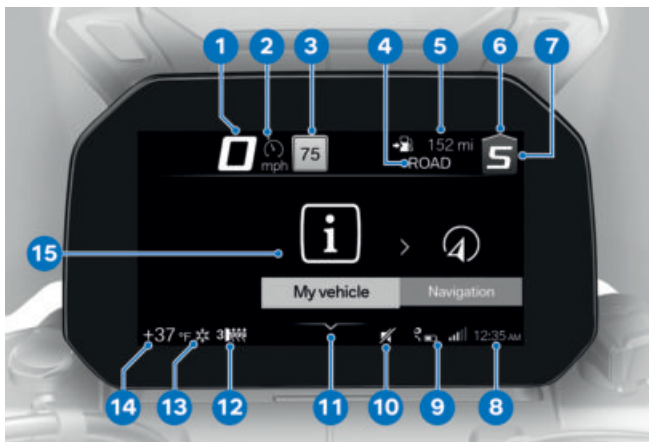

- | | |
|--|---|
| 1 Speedometer | 13 External temperature warning (☰☰☰ 39) |
| 2 Cruise control (☰☰☰ 92) | 14 Outside temperature |
| 3 Speed Limit Info (☰☰☰ 71) | 15 Menu area |
| 4 Riding mode (☰☰☰ 88) | |
| 5 Status line (☰☰☰ 64) | |
| 6 Upshift recommendation (☰☰☰ 32) | |
| 7 Gear display | |
| 8 Clock (☰☰☰ 66) | |
| 9 Connection status (☰☰☰ 67) | |
| 10 Muting (☰☰☰ 65) | |
| 11 Operating assistance | |
| 12 Heated grip settings (☰☰☰ 97) | |

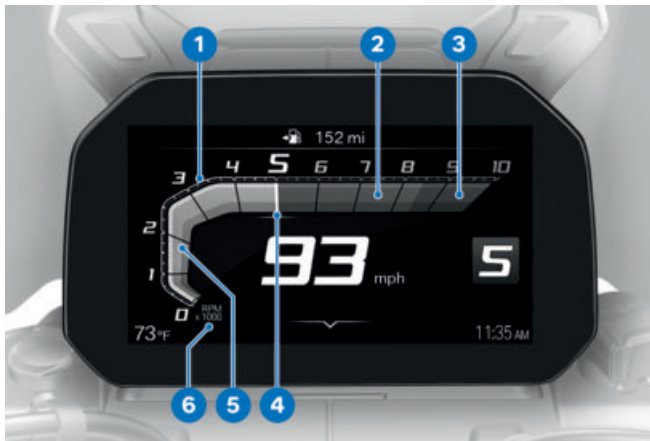
TACHOMETER

- 1 Scale
- 2 Rotational speed range
- 3 High / red engine speed range
- 4 Needle
- 5 Drag pointer
- 6 Unit for tachometer:
1000 RPM

32 DISPLAYS

UPSHIFT RECOMMENDATION



The upshift recommendation in the **1** status line or in the Pure Ride **2** view signals the economically best time for an upshift.

INDICATOR LIGHTS

Layout

Warnings are indicated by the corresponding warning light. Warnings are indicated by the general warning light in combination with a dialog in the instrument cluster. The general warning light lights up in either yellow or red, depending on the urgency of the warning.

 The general warning light lights up for whichever warning is most urgent at the current time.

You will find an overview of the potential warnings on the following pages.



Check Control display

The messages in the display are shown differently in the display. Different colors and characters are used depending on the priority:

- Green CHECK OK **1**: No message, optimal values.
- White circle with lowercase "i" **2**: Information.
- Yellow warning triangle **3**: Warning, value not optimal.
- Red warning triangle **3**: Warning, value critical



Value display

The icons **4** are displayed differently. Different colors are used depending on the assessment of value. Instead of numerical values **8** with units **7**, texts **6** are also displayed:

Color of the icon

- Green: (OK) Current value is optimal.
- Blue: (Cold!) Current temperature is too low.
- Yellow: (Low!/High!) Current value is too low or too high.
- Red: (Hot!/High!) Current temperature or value is too high.
- White: (---) There is no valid value. Instead of the value, dashes **5** are displayed.

 The evaluation of the individual values is possible in part only after a certain riding duration or speed. If a measured value cannot yet be displayed due to unfulfilled mea-

surement conditions, dashes are displayed instead as placeholders. As long as no valid measured value is available, no evaluation is carried out in the form of a colored symbol.

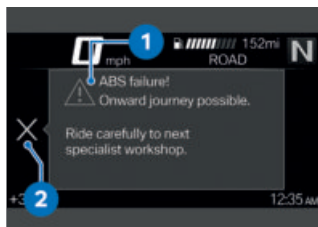

















Check Control dialog

















Messages are output as Check Control dialog **1**.

- If several Check Control messages of the same priority are present, the messages change in the order in which they occur, until they are acknowledged.
- If the icon **2** is active, you can acknowledge this by tilting the Multi-Controller to the left.
- Check Control messages are dynamically added to the screens in the My vehicle menu as additional tabs ( 62). You can go back to the message as long as the fault is present.



















34 DISPLAYS

















Overview of warning indicators

Indicator and warning lights	Display text	Meaning
	 is displayed.	External temperature warning (▶▶▶▶ 39)
 lights up yellow.	 Remote key not in range.	Radio-operated key outside reception range (▶▶▶▶ 39)
 lights up yellow.	 Keyless Ride failure!	Keyless Ride malfunction (▶▶▶▶ 40)
 lights up yellow.	 Remote key battery low.	Replacing the battery of the radio-operated key (▶▶▶▶ 40)
	 Vehicle voltage low.	Voltage of the vehicle electrical system too low (▶▶▶▶ 40)
 lights up yellow.	 Vehicle voltage critical!	Voltage of the vehicle electrical system is critical (▶▶▶▶ 41)
 flashes yellow.	 Battery critically low!	Charging voltage critical (▶▶▶▶ 41)
 lights up yellow.	 The faulty light source is displayed.	Light source faulty (▶▶▶▶ 42)
 lights up yellow.	 Light control failure!	Light control unit failed (▶▶▶▶ 42)





















Indicator and warning lights	Display text	Meaning
	 Anti-theft alarm batt. capacity low.	Anti-theft alarm system battery is weak (▣▣▣ 43)
	 Anti-theft alarm battery discharged.	Anti-theft alarm system battery discharged (▣▣▣ 43)
	 Anti-theft alarm system failure.	DWA malfunction (▣▣▣ 44)
 lights up yellow.	 Engine too hot!	Engine temperature high (▣▣▣ 44)
 lights up red.	 Engine overheating!	Engine overheated (▣▣▣ 44)
 lights up yellow.	 No communication with engine control.	Engine control malfunction (▣▣▣ 45)
 lights up.		
 lights up yellow.	 Fault in the engine control.	Engine in emergency operation mode (▣▣▣ 45)
 flashes red.	 Serious fault in the engine control.	Serious fault in the engine control (▣▣▣ 46)
 lights up yellow.	 is displayed in yellow.	Tire pressure is the limit range of approved tolerance (▣▣▣ 48)
	 Tire pressure not at setpoint.	

36 DISPLAYS

Indicator and warning lights	Display text	Meaning
 flashes red.	 is displayed in red.	Tire pressure is outside the approved tolerance range (➡ 48)
	 Tire pressure not at setpoint.	
	 Tire Press. Monitor. Loss of pressure.	
	 "----"	Transmission fault (➡ 49)
 lights up yellow.	 "----"	Sensor faulty or system fault (➡ 50)
 lights up yellow.	 TPM sensors battery low.	Battery of the tire pressure sensor weak (➡ 50)
 lights up yellow.	 Tire Press. Monitor failure!	Tire Pressure Monitor (TPM) malfunction (➡ 50)
	 Fall sensor faulty.	Malfunction of fall sensor (➡ 51)
 lights up yellow.	 Emergency call system failure.	Emergency call function has limited availability (➡ 51)
 lights up yellow.	 Emergency call system failure.	Emergency call function failed (➡ 51)
 lights up yellow.	 Side stand monitoring faulty	Malfunction of side stand monitor (➡ 51)

Indicator and warning lights	Display text	Meaning
 flashes.		ABS self-diagnosis not completed (→ 52)
 lights up yellow.	 Limited ABS availability!	ABS fault (→ 52)
 lights up.		
 lights up yellow.	 ABS failure!	ABS failure (→ 52)
 lights up.		
 lights up yellow.	 ABS Pro failure!	ABS Pro failure (→ 53)
 lights up.		
 flashes irregularly.		ABS-control on front wheel only (→ 53)
 flashes rapidly.		DTC intervention (→ 53)
 flashes slowly.		DTC self-diagnosis not completed (→ 54)
 lights up.	 Off!  Traction control deactivated.	DTC turned off (→ 54)

38 DISPLAYS

Indicator and warning lights	Display text	Meaning
 lights up yellow.	 Traction control limited.	Limited DTC availability ( 54)
 lights up.		
 lights up yellow.	 Traction control failure!	DTC error ( 55)
 lights up.		
	 Fuel reserve is being used up. Ride to the nearest gas station	Fuel has reached reserve volume ( 55)
	 flashes.	Gear not taught in ( 56)
 flashes in green.		Hazard warning flasher switched on ( 56)
 flashes in green.		
	 is displayed in white.	Service due ( 57)
	Service due!	
 lights up yellow.	 is displayed in yellow.	Service appointment overdue ( 57)
	Service overdue!	

Outside temperature

The outside temperature is displayed in the status line of the TFT display.

Engine heat can lead to spurious measurement readings of the outside temperature when the vehicle is stationary. If the effect of the motor heat becomes excessive, dashes are temporarily displayed instead of the value.



If the outside temperature falls below the limit value of approx. 37 °F (approx. 3 °C), there is a risk of black ice formation.

The first time the temperature drops below this value, the outside temperature display and ice crystal symbol will blink in the status line of the TFT display.

External temperature warning



is displayed.

Possible cause:

	<p>The outside temperature measured on the vehicle is less than:</p>
<p>Approx. 37 °F (Approx. 3 °C)</p>	



WARNING

Risk of black ice, even above approx. 37 °F (approx. 3 °C)

Risk of accident

- At a low outside temperature, icy conditions must be expected on bridges and in shady road areas.

- Use caution when riding.

Radio-operated key outside reception range

—with Keyless Ride^{OE}



lights up yellow.



Remote key not in range. It is not possible to turn on the ignition again.

Possible cause:

The communication between the radio-operated key and the engine electronics is faulty.

- Check the battery in the radio-operated key. —with Keyless Ride^{OE}
- Replace the battery of the radio-operated key. (→ 79)
- Use the spare key for further travel.

40 DISPLAYS

–with Keyless Ride^{OE}

- Battery of radio-operated key is dead or radio-operated key is lost. (➔ 79)
- If the Check Control dialog appears while riding, remain calm. You can continue riding; the engine will not turn off.
- Have a faulty radio-operated key replaced by an authorized BMW Motorrad retailer.

Keyless Ride malfunction

–with Keyless Ride^{OE}



lights up yellow.



Keyless Ride failure! Do not stop engine. Engine restart may not be possible.

Possible cause:

The Keyless Ride control unit has diagnosed a communication fault.

- Do not shut off the engine. Visit a repair shop immediately if possible, ideally an authorized BMW Motorrad dealer.
- » Engine start can no longer be turned on using Keyless Ride.
- » DWA can no longer be activated.

Replacing the battery of the radio-operated key

–with Keyless Ride^{OE}



lights up yellow.



Remote key battery low. Function limited. Change battery.

Possible cause:

- The battery for the radio-operated key is no longer charged to full capacity. Operation of the radio-operated key is only ensured for a limited time.
- Replace the battery of the radio-operated key. (➔ 79)

Voltage of the vehicle electrical system too low



Vehicle voltage low. Switch off unneeded consumers.

The vehicle voltage is too low. If you continue riding, the vehicle electronics will discharge the battery.

Possible cause:

Electrical loads with high electrical consumption, e.g. heating vests, are in operation; too many electrical loads are in operation at the same time, or the battery is defective.

- Switch off electrical loads that are not needed or disconnect

them from the electrical system.

- If the fault persists or occurs without any electrical loads connected, have the fault corrected as soon as possible at a repair shop, preferably an authorized BMW Motorrad dealer.

Voltage of the vehicle electrical system is critical



lights up yellow.



Vehicle voltage critical! Consumers were switched off Check battery condition.



WARNING

Failure of vehicle systems

Accident hazard

- Do not continue riding.

The vehicle voltage is critical.

The vehicle electronics will drain the battery.

Possible cause:

Electrical loads with high electrical consumption, e.g. heating vests, are in operation; too many electrical loads are in operation at the same time, or the battery is defective.

- Switch off electrical loads that are not needed or disconnect

them from the electrical system.

- If the fault persists or occurs without any electrical loads connected, have the fault corrected as soon as possible at a repair shop, preferably an authorized BMW Motorrad dealer.

Charging voltage critical



flashes yellow.



Battery critically low! Risk of accident. Do not continue to operate vehicle.



WARNING

Failure of vehicle systems

Accident hazard

- Do not continue riding.

The battery is not being charged. The vehicle electronics will drain the battery. Possible cause:

Alternator is malfunctioning, battery is defective or fuse is burned through.

- Have the malfunction corrected as soon as possible at a repair shop, preferably an authorized BMW Motorrad dealer.

42 DISPLAYS

Light source faulty



lights up yellow.



The faulty light source is displayed:



High beam faulty!



Turn indicator front left faulty! or Turn indicator front right faulty!



Low beam faulty!



Front parking lamp faulty!



Tail light faulty!



Brake light faulty!

–with LED additional headlight^{OA}



Left auxiliary headlight faulty! or Right auxiliary headlight faulty! <



Rear left turn signal faulty! or Rear right turn signal faulty!



License plate light faulty!

–Have checked by a specialist workshop.



WARNING

Overlooking the vehicle in road traffic due to failure of the lighting on the vehicle

Safety risk

- Replace defective lighting as soon as possible. Please contact a repair shop for this purpose, preferably an authorized BMW Motorrad dealer.

Possible cause:

Light source defective.

- Locate faulty light sources by means of a visual inspection.
- Have the LED light source replaced in full; for details please contact a specialist workshop, preferably an authorized BMW Motorrad retailer.

Light control unit failed



lights up yellow.



Light control failure! Have checked by a specialist workshop.

**WARNING****Overlooking the vehicle in road traffic due to failure of the vehicle lighting**

Safety risk

- Have the malfunction corrected as soon as possible at a repair shop, preferably an authorized BMW Motorrad dealer.

The vehicle lighting has failed partially or completely.

Possible cause:

The light control unit has diagnosed a communication fault.

- Have the malfunction corrected as soon as possible at a repair shop, preferably an authorized BMW Motorrad dealer.

Anti-theft alarm system battery is weak

–with anti-theft alarm system (DWA)^{OE}

 Anti-theft alarm batt. capacity low. No limitations. Arrange an appointment at a specialist workshop.

 This fault message is only shown for a short time immediately following the Pre-Ride-Check.

Possible cause:

The anti-theft alarm system battery no longer has its full capacity. The operation of the anti-theft alarm system is only ensured for a limited time with the vehicle battery disconnected.

- Contact a repair shop, preferably an authorized BMW Motorrad dealer.

Anti-theft alarm system battery discharged

–with anti-theft alarm system (DWA)^{OE}



Anti-theft alarm battery discharged. No independent alarm. Arrange an appointment at a specialist workshop.

 This fault message is only shown for a short time immediately following the Pre-Ride-Check.

Possible cause:

The DWA battery no longer has any charging capacity. Operation of the DWA is no longer guaranteed when the vehicle battery is disconnected.

- Contact a repair shop, preferably an authorized BMW Motorrad dealer.

44 DISPLAYS

DWA malfunction

–with anti-theft alarm system (DWA)^{OE}

 Anti-theft alarm system failure. Have checked by a specialist workshop.

Possible cause:

The DWA control unit has diagnosed a communication fault.

- Contact a repair shop, preferably an authorized BMW Motorrad dealer.
- » DWA can no longer be activated or deactivated.
- » False alarm possible.

Engine temperature high

 lights up yellow.

 Engine too hot! Continue driving at low revs to cool engine.

ATTENTION

Riding with overheated engine

Engine damage

- Be sure to observe the measures listed below.

Possible cause:

Coolant level is too low.

- Check the coolant level. (▶▶▶ 160)

If coolant level is too low:

- Allow the engine to cool down. Top up coolant. Have the cooling system checked at a repair shop, preferably by an authorized BMW Motorrad dealer.

Possible cause:

The temperature sensor has detected a high temperature in the engine.

- Ride in the partial load range if possible to cool the engine.
- If the engine temperature is more frequently too high, have the fault rectified as quickly as possible by a repair shop, preferably an authorized BMW Motorrad retailer.

Engine overheated

 lights up red.

 Engine overheating! Come to a safe stop, then stop the engine.

**ATTENTION****Riding with overheated engine**

Engine damage

- Be sure to observe the measures listed below.

Possible cause:

Coolant level is too low.

- Check the coolant level.

(160)

If coolant level is too low:

- Allow the engine to cool down. Top up coolant. Have the cooling system checked at a repair shop, preferably by an authorized BMW Motorrad dealer.

Possible cause:

Engine is overheated.

- Carefully come to a stop and turn off the engine until it has cooled down.
- If the engine overheats more frequently, have the fault corrected as soon as possible by a repair shop, preferably an authorized BMW Motorrad dealer.

Engine control malfunction

lights up yellow.



lights up.



No communication with engine control. Multiple sys. affected. Ride carefully to the next specialist workshop

Possible cause:

Communication with the engine control unit has malfunctioned.

- You may continue riding. Have the malfunction corrected as soon as possible at a repair shop, preferably an authorized BMW Motorrad dealer.

Engine in emergency operation mode

lights up yellow.



Fault in the engine control. Onward journey possible. Ride carefully to next specialist workshop.

**WARNING****Unusual handling when the engine is in emergency operation**

Accident hazard

- Avoid rapid acceleration and passing maneuvers.

46 DISPLAYS

Possible cause:

The engine control unit has diagnosed a fault. In exceptional cases, the engine stops and can no longer be started. Otherwise, the engine runs in emergency operation.

- Continued riding is possible, however, the accustomed engine power may not be available.
- Have the malfunction corrected as soon as possible at a repair shop, preferably an authorized BMW Motorrad dealer.

Serious fault in the engine control



flashes red.



Serious fault in the engine control. Onward journey possible. Damage possible. Have checked by a workshop.



WARNING

Damage to the engine during emergency operation

Risk of accident

- Drive slowly and refrain from accelerating quickly and overtaking other vehicles.
- If possible, have the vehicle picked up and let the malfunction be corrected at a repair shop, preferably an authorized BMW Motorrad dealer.

Possible cause:

The engine control unit has diagnosed a fault, which can lead to a severe consequential fault. The engine is in emergency operation.

- Continued riding is possible, however it is not recommended.
- Avoid high load and engine speed ranges if possible.
- Have the malfunction corrected as soon as possible at a repair shop, preferably an authorized BMW Motorrad dealer.

Tire pressure

–with tire pressure monitor (TPM)^{OE}

In addition to the MY VEHICLE menu screen and the Check Control messages, there is also the TIRE PRESSURE screen to display the tire pressures:



The values on the left refer to the front wheel, and the values on the right refer to the rear wheel.

In addition to the actual tire pressure values, the setpoint tire pressure values are displayed based on the vehicle load.

Immediately after the ignition is turned on, only dashes are displayed. The transfer of the actual tire pressure values does not begin until the following minimum speed is exceeded for the first time:



RDC sensor is not active

min 19 mph (min 30 km/h)
(The RDC sensor transmits its signal to the vehicle only once the minimum speed has been exceeded.)



The tire pressures are shown in the TFT display with temperature compensation and are always based on the following tire air temperature:

68 °F (20 °C)



If the tire icon appears yellow or red at the same time, the display is a warning.



The tolerance ranges of the tire pressures refer to one-up operation.



If the value in question is within the limit range of the permitted tolerance, the general warning light also lights up yellow.



If the determined tire pressure is outside the permitted tolerance, the general warning light blinks red.

48 DISPLAYS

For further information about the BMW Motorrad tire pressure control (TPM), see the Technology in detail (▶▶▶ 144) chapter.

Tire pressure is the limit range of approved tolerance

–with tire pressure monitor (TPM)^{OE}

 lights up yellow.

 is displayed in yellow.

 Tire pressure not at setpoint. Check tire pressure.

Possible cause:

The measured tire pressure is within the limit range of the permissible tolerance.

- Correct the tire pressure.
- Before adjusting the tire pressure, check the information on temperature compensation and tire pressure adjustment in the chapter "Technology in detail":
 - » Temperature compensation (▶▶▶ 145)
 - » Tire pressure adjustment (▶▶▶ 145)
 - » The target tire pressures can be found in the following locations:

- On the back cover of the rider's manual
- Instrument cluster in the TIRE PRESSURE view
- Tire pressure table

Tire pressure is outside the approved tolerance range

–with tire pressure monitor (TPM)^{OE}

 flashes red.

 is displayed in red.

 Tire pressure not at setpoint. Stop immediately! Check tire pressure.

 Tire Press. Monitor. Loss of pressure. Stop immediately! Check tire pressure.

WARNING

Tire pressure is outside the approved tolerance range.

Risk of accident, deterioration in the handling characteristics of the vehicle.

- Adjust the driving style.

Possible cause:

The measured tire pressure is outside of the permissible tolerance.

- Check tire for damage and ridability.

If the tire is still rideable:

- Correct the tire pressure at the next opportunity.
- Before adjusting the tire pressure, check the information on temperature compensation and tire pressure adjustment in the chapter "Technology in detail":

» Temperature compensation (▣▣▣▣ 145)

» Tire pressure adjustment (▣▣▣▣ 145)

» The target tire pressures can be found in the following locations:

- On the back cover of the rider's manual
- Instrument cluster in the **TIRE PRESSURE** view
- Tire pressure table

- Have the tire checked by a repair shop for damage, preferably by an authorized BMW Motorrad dealer.

If you are unsure about the tire's rideability:

- Do not continue riding.
- Contact roadside service.

Transmission fault

–with tire pressure monitor (TPM)^{OE}

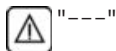

Possible cause:

The vehicle has not reached the minimum speed (▣▣▣▣ 144).



RDC sensor is not active

min 19 mph (min 30 km/h)
(The RDC sensor transmits its signal to the vehicle only once the minimum speed has been exceeded.)

- Observe the TPM display at higher speed. This is a permanent fault only when the general warning light also lights up. In this case:
- Have the fault corrected at a repair shop, preferably an authorized BMW Motorrad dealer.

Possible cause:

There is a fault in the radio link to the RDC sensors. Possible causes are radio systems in the surrounding area, which interfere with the connection between the TPM control unit and the sensors.

- Observe the RDC display in a different environment. This is

50 DISPLAYS

a permanent fault only when the general warning light also lights up. In this case:

- Have the fault corrected at a repair shop, preferably an authorized BMW Motorrad dealer.

Sensor faulty or system fault

—with tire pressure monitor (TPM)^{OE}



lights up yellow.



"----"

Possible cause:

Wheels without RDC sensors are installed.

- Retrofit wheel set with RDC sensors.

Possible cause:

One or two RDC sensors have failed or a system fault has occurred.

- Have the fault corrected at a repair shop, preferably an authorized BMW Motorrad dealer.

Battery of the tire pressure sensor weak

—with tire pressure monitor (TPM)^{OE}



lights up yellow.



TPM sensors battery low. Function limited. Have checked by a specialist workshop.



This fault message is only shown for a short time immediately following the Pre-Ride-Check.

Possible cause:

The battery for the tire pressure sensor is no longer charged to full capacity. Operation of the Tire Pressure Monitor is only ensured for a limited time.

- Contact a repair shop, preferably an authorized BMW Motorrad dealer.

Tire Pressure Monitor (TPM) malfunction



lights up yellow.



Tire Press. Monitor failure! Function limited. Have checked by a specialist workshop.

Possible cause:

The TPM control unit has diagnosed a communication fault.

- Contact a repair shop, preferably an authorized BMW Motorrad dealer.

» Tire pressure warnings not available.

Malfunction of fall sensor

 Fall sensor faulty. Have checked by a specialist workshop.

Possible cause:

The fall sensor is not functioning.

- Contact a repair shop, preferably an authorized BMW Motorrad dealer.

Emergency call function has limited availability

–with intelligent emergency call^{OE}

 lights up yellow.

 Emergency call system failure. Schedule an appointment at a specialist workshop.

Possible cause:

The emergency call cannot be established automatically or via BMW.

- Please refer to page  82 for information on using the intelligent emergency call.
- Contact a repair shop, preferably an authorized BMW Motorrad dealer.

Emergency call function failed
–with intelligent emergency call^{OE}

 lights up yellow.

 Emergency call system failure. Schedule an appointment at a specialist workshop.

Possible cause:

The control unit of the Assist system has diagnosed a fault. The emergency call function has failed.

- Note that the emergency call cannot be placed.
- Contact a repair shop, preferably an authorized BMW Motorrad dealer.

Malfunction of side stand monitor

 lights up yellow.

 Side stand monitoring faulty Onward journey possible. Stop engine when stationary! Have checked by workshop.

52 DISPLAYS

Possible cause:



The side support switch or its wiring is damaged

The engine is turned off if the speed falls below the minimum limit. The journey cannot be continued.

min 3 mph (min 5 km/h)

- Contact a repair shop, preferably an authorized BMW Motorrad dealer.

ABS self-diagnosis not completed



flashes.

Possible cause:

The ABS is not available because the self-diagnosis has not been completed. To check the wheel sensors, the motorcycle must be driven a few yards.

- Ride off slowly. It must be noted that the ABS function is not available until the self-diagnosis has been completed.

ABS fault



lights up yellow.



lights up.



Limited ABS availability! Onward journey possible. Ride carefully to next specialist workshop.

Possible cause:

The ABS control unit has detected an error. The ABS function is limited.

- You may continue riding. Take note of additional information on special situations that can lead to an ABS fault message (▶▶▶ 137).
- Have the malfunction corrected as soon as possible at a repair shop, preferably an authorized BMW Motorrad dealer.

ABS failure



lights up yellow.



lights up.



ABS failure! Onward journey possible. Ride carefully to next specialist workshop.

Possible cause:

The ABS control unit has detected an error. The ABS function is not available.

- You may continue riding. Take note of additional information on special

situations that can lead to an ABS fault message (▮▮▮▮ 137).

- Have the malfunction corrected as soon as possible at a repair shop, preferably an authorized BMW Motorrad dealer.

ABS Pro failure



lights up yellow.



lights up.



ABS Pro failure! Onward journey possible. Ride carefully to next specialist workshop.

Possible cause:

The monitoring of the ABS Pro function has detected a fault. The ABS Pro function is not available. The ABS function remains available. ABS only supports braking in straight-ahead riding.

- You may continue riding. Observe additional information on special situations that can lead to a ABS Pro fault message (▮▮▮▮ 137).
- Have the malfunction corrected as soon as possible at a repair shop, preferably an authorized BMW Motorrad dealer.

ABS-control on front wheel only

–with riding modes Pro^{OE}



flashes irregularly.

Possible cause:

The ABS control for the rear wheel is turned off in the currently selected riding mode. The rear wheel brake can block the rear wheel.

- Check the settings of the riding mode.
- More detailed information on configuring the riding modes can be found in the "Technology in detail" chapter (▮▮▮▮ 142).

DTC intervention



flashes rapidly.

Possible cause:

DTC has detected instability at the rear wheel and responded by reducing the torque.

The indicator and warning light flashes longer than the DTC intervention lasts. This provides the rider with visual feedback for the control action that was taken even after the critical riding situation has passed.

- You may continue riding. Use caution when riding.

54 DISPLAYS

DTC self-diagnosis not completed

 flashes slowly.

Possible cause:

 DTC self-diagnosis not completed

The DTC function is not available, as the self-diagnosis function has not been completed. (To check wheel speed sensors, motorcycle must reach a minimum speed with engine running: min 3 mph (min 5 km/h))

- Ride off slowly. Note that the DTC function is only available after the self-diagnosis has been completed.

DTC turned off

 lights up.

 Off!

 Traction control deactivated.

Possible cause:

The DTC system was turned off by the rider.

- Turn on the DTC. (▮▮▮ 87)

Limited DTC availability

 lights up yellow.

 lights up.

 Traction control limited. Onward journey possible. Ride carefully to next specialist workshop.

Possible cause:

The engine control unit has detected a DTC fault.

ATTENTION

Damage to components

Damage to sensors, for example, with the resultant malfunctions

- Do not carry along any objects under the rider's or passenger's seat.
- Secure vehicle tools.
- Do not damage the angular rate sensor.
- Note that the DTC function and other electronic stability control systems are available with limitations only.
- You may continue riding. Observe additional information on situations that can lead to a DTC fault (▮▮▮ 139).
- Have the malfunction corrected as soon as possible

at a repair shop, preferably an authorized BMW Motorrad dealer.

DTC error



lights up yellow.



lights up.



Traction control failure! Onward journey possible. Ride carefully to the next specialist workshop.

Possible cause:

The engine control unit has detected a DTC fault.



ATTENTION

Damage to components

Damage to sensors, for example, with the resultant malfunctions

- Do not carry along any objects under the rider's or passenger's seat.
- Secure vehicle tools.
- Do not damage the angular rate sensor.
- Note that the DTC function and other electronic stability control systems are not available.
- You may continue riding. Observe additional information

on situations that can lead to a DTC fault (▮▮▮▮ 139).

- Have the malfunction corrected as soon as possible at a repair shop, preferably an authorized BMW Motorrad dealer.

Fuel has reached reserve volume



Fuel reserve is being used up. Drive to the nearest filling station.



WARNING

Rough engine running or switching off of the engine due to a fuel shortage

Accident hazard, damage to catalytic converter

- Do not drive to the extent that the fuel tank is completely empty.

Possible cause:

At most, the fuel tank contains only the reserve volume.



Reserve fuel quantity

Approx. 1.1 gal (Approx. 4 l)

- Refueling procedure. (▮▮▮▮ 128)

56 DISPLAYS

Gear not taught in

–with Gearshift Assistant Pro^{OE}

N The gear indicator flashes. The Gear Shift Assistant Pro has no function. Possible cause:

The transmission sensor has not been completely taught in.

- Start engine. (►► 119)
 - Shift to neutral N.
 - Fold the side stand out and back in; do not operate the gearshift lever while doing this.
 - Shift all gears with clutch control. In the respective gear, put the throttle grip in the idle position multiple times and then accelerate again.
- » The gear display stops blinking when the transmission sensor has been successfully taught in.
- Once the transmission sensor has been fully taught in, the Gear Shift Assistant Pro functions as described (►► 146).
- If the teach-in procedure is unsuccessful, have the fault corrected at a repair shop, preferably an authorized BMW Motorrad dealer.

Hazard warning flasher switched on



flashes in green.



flashes in green.

Possible cause:

The hazard warning flasher was switched on by the rider.

- Operate hazard warning flashers. (►► 86)

Service display



If service is overdue, the service date or the distance covered at which service should have been completed is accompanied by the general warning light in yellow.

If service is overdue, a yellow Check Control message is displayed. The displays for service, service appointment and remaining distance are also marked with exclamation marks in the MY VEHICLE and SERVICE REQUIREMENTS menu windows.



If the service display appears more than a month before the service date, the current day's date must be reset. This situation can occur if the battery was disconnected.

Service due

is displayed in white.

Service due! Have a service performed at a specialist workshop.

Possible cause:

Service is due because of the mileage or the date.

- Have service performed regularly by a specialist workshop, preferably an authorized BMW Motorrad retailer.

» The operating and road safety of the vehicle remains unchanged.

» The best-possible value retention of the vehicle is ensured.

Service appointment overdue

lights up yellow.



is displayed in yellow.

Service overdue! Have a service performed at a specialist workshop.

Possible cause:

Service is overdue because of the riding performance or the date.

- Have service performed regularly by a specialist workshop, preferably an authorized BMW Motorrad retailer.

» The operating and road safety of the vehicle remains unchanged.

» The best-possible value retention of the vehicle is ensured.

INSTRUMENT CLUSTER

04

WARNINGS	60
OPERATING ELEMENTS	60
MY VEHICLE	63
SETTINGS	64
BLUETOOTH PAIRING	66
OPERATING FOCUS	68
NAVIGATION	69
MEDIA	71
TELEPHONE	72
SOFTWARE VERSION	72
LICENSE INFORMATION	72

60 INSTRUMENT CLUSTER

WARNINGS



WARNING

Operation of a smartphone while riding

Risk of accident

- Observe the valid road traffic regulations.
- Do not use any smartphone while riding. Applications that do not involve operation are exempt, such as phone calls using a hands-free system.



WARNING

Distraction from traffic conditions and loss of control

Risk of accident through the use of integrated information systems and communication devices during the journey

- Operate these systems or devices only if the traffic situation allows.
- If necessary, stop and operate the system or devices at a standstill.

OPERATING ELEMENTS

Multi-Controller

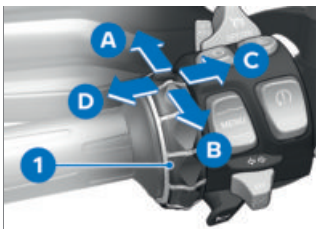

- 1** Multi-Controller
- A** Move the cursor up in lists
Increases the volume
- B** Move the cursor down in lists
Decrease volume
- C** Activate the function according to the feedback
Confirm selection/setting
Browsing through menu screens
- D** Activate or deactivate the function according to the feedback
After settings, return to menu view
Change one hierarchy level up
Browsing through menu screens

Rocker button MENU

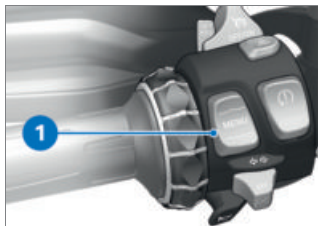

Briefly press the top of the MENU 1:

- In Menu view: Change a hierarchy level up.
- In Pure Ride view: Changing the display for rider info. status line.

Press and hold the top of the MENU 1:

- In Menu view: Open Pure Ride view.
- In Pure Ride or Sport view: Change the operating focus to the navigator.

Press the bottom of the MENU 1:

- Change a hierarchy level down.
- Confirm the selection/setting.

Press and hold the bottom of the MENU 1:

- Return to the last menu, after a menu change has been previously carried out by pressing

and holding the top of the rocker button.

 Navigation instructions are displayed as a dialog if you have not gone to the Navigation menu. Operation of the MENU rocker button is temporarily restricted.

Show Pure Ride view

- Press and hold the top of the rocker button MENU.

Go to the menu

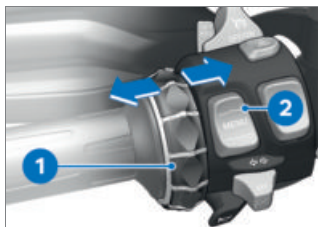

- Show Pure Ride view. (▣▣▣ 61)
- Briefly press button **2** downward.

The following menus can be called up:

- My vehicle
- Navigation
- Media
- Telephone
- Settings
- Press Multi-Controller **1** repeatedly briefly to the right until the desired menu item is marked.

62 INSTRUMENT CLUSTER

- Briefly press button **2** downward.

 The **Settings** menu can only be called up when stationary.

Operating instructions in the main menu

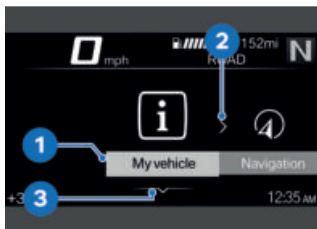

The operating instructions indicate whether and which interactions are possible.

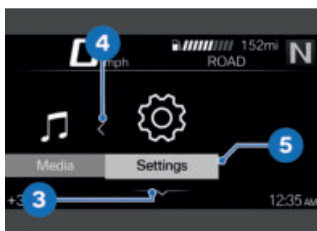

Meaning of the operating instructions:

- Operating instructions **1**: The left end has been reached.
- Operating instructions **2**: You can scroll to the right.

- Operating instructions **3**: You can scroll down.
- Operating instructions **4**: You can scroll to the left.
- Operating instructions **5**: The right end has been reached.

Operating instructions in submenus

In addition to the operating instructions in the main menu, there are additional operating instructions in submenus.

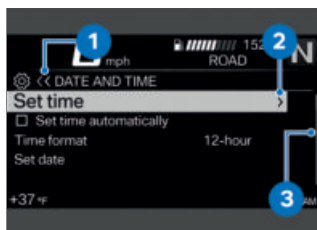

Meaning of the operating instructions:

- Operating instructions **1**: The current display is in a hierarchical menu. The number of icons indicates up to three submenu levels. The color of the icon changes depending on whether there is an option to return to the top.
- Operating instructions **2**: You can go to another submenu level.

–Operating instructions 3:

There are more entries than can be displayed.

Switching functions on and off

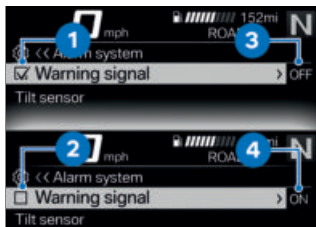

Some items are preceded by a box. The box indicates whether the function is turned on or switched off. Action icons after the menu items illustrate what is switched by briefly tilting the Multi-Controller to the right.

Examples for switching on and off:

- Icon 1 indicates that the function is turned on.
- Icon 2 indicates that the function is turned off.
- Icon 3 indicates that the function can be turned off.
- Icon 4 indicates that the function can be turned on.

System status displays

The system status is displayed in the lower menu area when a function has been turned on or switched off.



Example of the meaning of the system statuses:

- System status 1: DTC function is turned on.

MY VEHICLE

Calling up the on-board computer

- Go to the My vehicle menu.
- Scroll to the right until the ONBOARD COMPUTER menu screen is displayed.

Resetting the on-board computer

- Go to the on-board computer. (▶▶▶ 63)
- Press MENU rocker button down.
- Select Reset all values or Reset individual values and confirm.

64 INSTRUMENT CLUSTER

The following values can be reset individually:



Break



Journey



Current



Speed



Consump.

Calling up the travel on-board computer

- Go to the on-board computer. (▣▣▣▣ 63)
- Scroll to the right until the TRIP COMPUTER menu screen is displayed.

Resetting the travel on-board computer

- Go to the travel on-board computer. (▣▣▣▣ 64)
- Press MENU rocker button down.
- Select Automatic reset or Reset all values and confirm.
- » If Automatic reset is selected, the travel on-board computer is automatically reset if at least 6 hours have passed since the ignition was

switched off and the date has changed.

SETTINGS

Selecting content of upper status line

- Go to menu Settings, Display, Status line content.
- Turn on desired displays.
 - » It is possible to change between the selected displays in the upper status line. If no displays are selected, only the range is shown.

Changing the status line display

Requirement

The vehicle is stationary. The Pure Ride view is displayed.





- Turn on the ignition. (▣▣▣▣ 76)
 - » In the instrument cluster, all of the information necessary for operating the vehicle on public roads is made available from the on-board computer (e.g. TRIP 1) and travel on-board computer (e.g. TRIP 2). The information can be displayed in the upper status line.







- with tire pressure monitor (TPM)^{OE}
- » In addition, information from the Tire Pressure Monitor can be displayed.<
- Select content of upper status line. (▶▶▶ 64)





- Press and hold button **1** to display the Pure Ride view.
- Press button **1** briefly to select the value in the upper status line **2**.

The following values can be displayed:

-  Total distance
-  Current distance 1
-  Current distance 2
-  Consumption 1 (average)
-  Consumption 2 (average)

-  Riding time 1
-  Riding time 2
-  Break 1
-  Break 2
-  Speed 1 (average)
-  Speed 2 (average)

-with tire pressure monitor (TPM)^{OE}

-  Tire pressure<
-  Fuel tank level
-  Range

Adjusting the volume

- Connect the rider's helmet and the passenger helmet. (▶▶▶ 68)
- Increase volume: Turn the Multi-Controller up.
- Decrease volume: Turn the Multi-Controller down.
- Mute: Turn the Multi-Controller all the way down.

66 INSTRUMENT CLUSTER

Configuring system settings

- Call up menu **Settings**,
System settings.
- » The following system settings can be configured here:
 - Date and time
 - Units
 - Language

Adjusting brightness

- Go to menu **Settings**,
Display, **Brightness**.
- Adjust brightness.
- » The brightness of the display is dimmed to the set value if ambient brightness falls below a defined value.

Resetting all settings

- Go to the **Settings** menu.
- Select **Reset all** and confirm.

The settings of the following menus are reset:

- Vehicle settings
- System settings
- Connections
- Display
- Information

- » Existing Bluetooth connections are not deleted.
- » The pairing of the vehicle with the current BMW Motorrad Connected-Ride account is reset.

BLUETOOTH PAIRING

Pairing

Two Bluetooth devices have to recognize each other before they can communicate. This process of mutual recognition is known as pairing. When two devices have paired they remember each other, so the pairing process is conducted only once, on initial contact.



On some mobile terminals, e.g. with operating system iOS, you must go to the BMW Motorrad Connected App before use.

During the pairing process, the instrument cluster searches for other Bluetooth-compatible devices within its reception range. The conditions that have to be satisfied before a device can be detected are as follows:

- The Bluetooth® function of the device must be activated
- The device must be "visible" to others
- Other Bluetooth-capable devices must be OFF (e.g. mobile phones and navigation systems).

Please consult the operating instructions for your communication system.

Carrying out pairing

- Call up menu `Settings`, `Connections`.
- » Bluetooth connections can be established, managed, and deleted in the `CONNECTIONS` menu. The following Bluetooth connections are displayed:

- Mobile device
- Rider's helmet
- Passenger helm.

The connection status for mobile end devices is displayed.

Connecting a mobile end device

- Carry out pairing. (▣▣▣ 67)
- Activate the Bluetooth function of the mobile end device (see operating instructions for the mobile end device).
- Select `Mobile device` and confirm.
- Select `Pair new mobile device` and confirm.

Mobile end devices are searched for.



During the pairing, the Bluetooth symbol flashes in the lower status line.

Visible mobile end devices are displayed.

- Select the mobile end device and confirm.



If the fuel tank is between the mobile terminal and the instrument cluster, the Bluetooth connection may be restricted. BMW Motorrad recommends storing the mobile terminal above the fuel tank (e.g. in the jacket pocket).

- Observe the instructions for the mobile end device.
- Confirm that the codes match.
- » The connection is established and the connection status is updated.
- » If the connection cannot be established, the troubleshooting chart in the Technical data chapter may provide assistance. (▣▣▣ 212)
- » Depending on the mobile end device, telephone data is transferred to the vehicle automatically.
- » Telephone data (▣▣▣ 72)
- » If the phone book is not displayed, the troubleshooting chart in the Technical data chapter may provide assistance. (▣▣▣ 213)
- » If the Bluetooth connection does not work as expected, the troubleshooting chart in the Technical data chapter may provide assistance. (▣▣▣ 213)

68 INSTRUMENT CLUSTER

Connect the rider's helmet and the passenger helmet

- Carry out pairing. (▶▶▶ 67)
- Select Rider's helmet or Passenger helm. and confirm.
- Show the communication system of the helmet.
- Select Pair new rider's helmet or Pair new passenger helmet and confirm.

Helmets are searched for.



During the pairing, the Bluetooth symbol flashes in the lower status line.

Visible helmets are displayed.

- Select helmet and confirm.
- » The connection is established and the connection status is updated.
- » If the connection cannot be established, the troubleshooting chart in the Technical data chapter may provide assistance. (▶▶▶ 212)
- » If the Bluetooth connection does not work as expected, the troubleshooting chart in the Technical data chapter may provide assistance. (▶▶▶ 213)

Deleting connections

- Call up menu Settings, Connections.
- Select Delete connections.
- To delete an individual connection, select the connection and confirm.
- To delete all connections, select Delete all connections and confirm.

OPERATING FOCUS

—with preparation for navigation system^{OE}

Changing operating focus

When the Navigator is connected, you can change between operation of the Navigator and of the instrument cluster.

Changing the operating focus

- Securely fasten the navigation device. (▶▶▶ 198)
- Show Pure Ride view. (▶▶▶ 61)
- Press and hold the top of the rocker button MENU.
- » Operating focus changes to the Navigator or the instrument cluster. The active device is marked in the upper left status line. Operating actions affect the active device until the operating focus is changed again.

» Operating the navigation system (▮▮▮ 200)

NAVIGATION

Prerequisite

The vehicle is connected to a compatible mobile end device via Bluetooth.

The BMW Motorrad Connected app is installed on the connected mobile terminal.

 On some mobile terminals, e.g. with operating system iOS, you must go to the BMW Motorrad Connected App before use.

Entering destination address

- Connect mobile terminal. (▮▮▮ 67)
- Go to the BMW Motorrad Connected app and start the guidance.
- Call up **Navigation** menu in the instrument cluster.
- » Active destination guidance is displayed.
- » If the active route guidance is not displayed, the troubleshooting chart in the Technical data chapter may provide assistance. (▮▮▮ 213)

Select destination from most recent destinations

- Call up menu **Navigation**, **Recent destinations**.
- Select destination and confirm.
- Select **Start route guidance**.

Select destination from favorites

- The **FAVORITES** menu shows all destinations that have been saved as a favorite in the BMW Motorrad Connected app. It is not possible to create new favorites in the instrument cluster.
- Call up menu **Navigation**, **Favorites**.
- Select destination and confirm.
- Select **Start guidance**.

Entering special destinations

- Special destinations, e.g. landmarks, can be displayed on the map.
- Call up menu **Navigation**, **POIs**.

The following locations can be selected:

- At current location
- At destination
- Along the route

70 INSTRUMENT CLUSTER

- Select in which location you want to search for special destinations.

The following point of interest can be selected:

- Filling station
- Select special destination and confirm.
- Select Start route guidance and confirm.

Specifying route criteria

- Call up menu Navigation, Route criteria.

The following criteria can be selected:

- Route type
- Avoid
- Select desired Route type.
- Turn desired Avoid on or off.

The number of enabled avoidances is displayed in brackets.

Display route info

- Go to the Navigation, Settings menu, then select the Route info menu item.

You can select between the following options:

- Destination
- Waypoint
- Select desired option.
- » The remaining distance and time are displayed.

Editing guidance

- Call up menu Navigation, New destination.

You can select between the following destinations:

- Recent destinations
- Favorites
- POIs
- Select destination from one of the three destination categories.
- Select Edit route guidance in the destination entry.
- Select Add stop to add the selected destination as a waypoint.
- Select Start guidance to overwrite the current destination.

Ending route guidance

- Call up menu Navigation, Active route guidance.
- Select and confirm End route guidance or tilt the Multi-Controller to the left.

Switching spoken instructions on or off

- Connect the rider's helmet and the passenger helmet. (🔊 68)
- The navigation can be read aloud. To do this, the Spoken instructions must be turned on.
- Call up menu Navigation, Active route guidance.

- Turn Spoken instructions on or off.

Repeating the last spoken instruction

- Call up menu Navigation, Active route guidance.
- Select Current instruction and confirm.

Turning Speed Limit Info on or off

Requirement

The vehicle is connected to a compatible mobile end device. The BMW Motorrad Connected app is installed on the mobile end device.

- Speed Limit Info displays the currently permitted maximum speed insofar as this information is provided by the editor of the maps in the navigation system.
- Call up menu Settings, Display.
- Turn Speed Limit Info on or off.

MEDIA

Prerequisite

The vehicle is connected to a compatible mobile end device and a compatible helmet.

Controlling audio playback

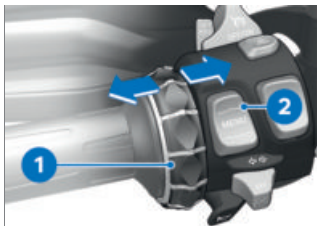

- Go to the Media menu.

 BMW Motorrad recommends setting the volume for media and conversations via mobile terminals to the maximum before starting a journey.

- Adjust the volume. (▶▶▶ 65)
- Next title: Briefly tilt Multi-Controller **1** to the right.
- Last title or beginning of the current title: Briefly tilt Multi-Controller **1** to the left.
- Fast forward: Tilt Multi-Controller **1** to the right for an extended period.
- Fast rewind: Tilt Multi-Controller **1** to the left for an extended period.
- Go to context menu: Press button **2** downward.

 Depending on the mobile terminal, the scope of the Connectivity functions may be limited.

» The following functions can be used in the context menu:

72 INSTRUMENT CLUSTER

- Playback or Pause.
- For search and playback, select the category Now playing, All artists, All albums or All tracks.
- Select Playlists.

In the submenu Audio settings, you can adjust the following settings:

- Switch Shuffle on or off.
- Select Repeat: Off, One (current title) or All.

TELEPHONE

Prerequisite

The vehicle is connected to a compatible mobile end device and a compatible helmet.

Making a phone call

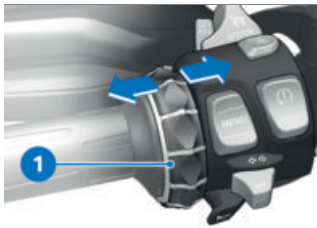

- Go to the Telephone menu.
- Accepting a call: Tilt Multi-Controller 1 to the right.
- Rejecting a call: Tilt Multi-Controller 1 to the left.
- Ending a call: Tilt Multi-Controller 1 to the left.

Muting

The microphone in the helmet can be muted during active conversations.

Conversations with multiple users

A second telephone call can be accepted during a conversation. The first conversation will be put on hold. The number of active calls is displayed in the Telephone menu. It is possible to switch between two conversations.

Telephone data

Depending on the mobile end device, telephone data is transferred to the vehicle automatically after pairing (➔ 66).

Phone book: List of contacts saved in the mobile terminal

Call list: List of calls with the mobile terminal

Favorites: List of favorites saved in the mobile terminal

SOFTWARE VERSION

- Go to menu Settings, Information, Software version.

LICENSE INFORMATION

- Go to menu Settings, Information, Licenses.

OPERATION

05

IGNITION SWITCH/STEERING LOCK	76
IGNITION WITH KEYLESS RIDE	77
ELECTRONIC IMMOBILIZER EWS	81
EMERGENCY-OFF SWITCH	81
INTELLIGENT EMERGENCY CALL	82
LIGHTING	84
TRACTION CONTROL (DTC)	87
RIDING MODE	88
PRO RIDING MODE	91
CRUISE CONTROL	92
ANTI-THEFT ALARM SYSTEM (DWA)	94
TIRE PRESSURE MONITOR (TPM)	97
HEATED GRIPS	97
SEAT	98

76 OPERATION

IGNITION SWITCH/STEERING LOCK

Ignition keys

You receive two ignition keys. Should you lose your keys, please refer to the notes regarding the electronic immobilizer (EWS) (▮▮▮ 81). The ignition lock, fuel filler cap and seat lock are operated with the same key.

—with case^{OA}

Cases with locks for the same key can be ordered on request. For this, please contact a repair shop, preferably an authorized BMW Motorrad dealer.

Locking the steering lock

- Turn handlebars to left.



- Turn key to position **1** while moving handlebars slightly.
 - » Ignition, lights and all electrical circuits turned off.
 - » Steering lock locked.

- » Ignition key can now be removed.

Turning on the ignition

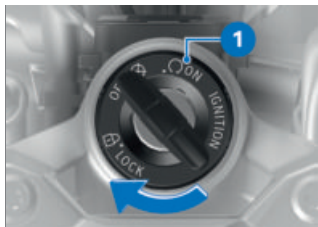

- Turn ignition key to position **1**.
 - » Parking lights and all function circuits turned on.
 - » Engine can be started.
 - » Pre-Ride-Check is carried out. (▮▮▮ 119)
 - » ABS self-diagnosis is performed. (▮▮▮ 120)
 - » DTC self-diagnosis is performed. (▮▮▮ 121)

Turning off the ignition

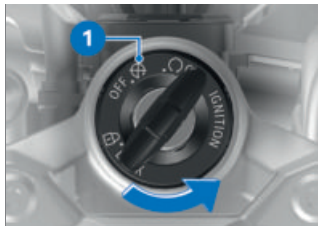

- Turn ignition key to position **1**.
 - » Light is turned off.

- » Steering lock is not locked.
- » Ignition key can now be removed.
- » Electrically powered accessories remain operational for a limited period of time.
- » Battery charging possible via the accessory power socket.

IGNITION WITH KEYLESS RIDE

—with Keyless Ride^{OE}

Ignition keys

 The indicator light for the radio-operated key flashes as long as the radio-operated key is being searched for. If the radio-operated key or the spare key is detected, it goes out.

If the radio-operated key or the spare key is not detected, it lights up briefly.

You are provided with one radio-operated key and one spare key. If you lose your keys, refer to the notes regarding the electronic immobilizer (EWS) ( 81).

The ignition, fuel filler cap and anti-theft alarm system are actuated with the radio-operated key. The seat lock and cases can be operated manually.

 When the range of the radio-operated key is exceeded (e.g. in case or Top-case), the vehicle cannot be started.

If the radio-operated key continues to be missing, the ignition will be turned off after approx. 90 seconds to protect the battery.

It is advisable to carry the radio-operated key directly on your person (e.g. in a jacket pocket) and to also carry the spare key as an alternative.

 Range of Keyless Ride radio-operated key

—with Keyless Ride^{OE}

Approx. 3.3 ft (Approx. 1 m)
◀

Locking the steering lock Requirement

Handlebars are turned to the left. Radio-operated key is within reception area.

78 OPERATION



- Press and hold button **1**.
 - » Steering lock audibly locks.
 - » Ignition, lights and all electrical circuits turned off.
- To unlock the steering lock, briefly press button **1**.

Turning on the ignition Requirement

Radio-operated key is within reception area.



- There are **two** ways to activate the ignition.

Version 1:

- Briefly press button **1**.
 - » Parking lights and all function circuits are turned on.
 - » Pre-Ride-Check is carried out. (▮▮▮▮▶ 119)

- » ABS self-diagnosis is performed. (▮▮▮▮▶ 120)
- » DTC self-diagnosis is performed. (▮▮▮▮▶ 121)

Version 2:

- Steering lock is locked; press and hold button **1**.
 - » Steering lock is unlocked.
 - » Parking lights and all function circuits turned on.
 - » Pre-Ride-Check is carried out. (▮▮▮▮▶ 119)
 - » ABS self-diagnosis is performed. (▮▮▮▮▶ 120)
 - » DTC self-diagnosis is performed. (▮▮▮▮▶ 121)

Turning off the ignition Requirement

Radio-operated key is within reception area.



- The ignition can be deactivated in **two** ways.

Version 1:

- Briefly press button **1**.
- » Light is turned off.
- » Steering lock is not locked.

Version 2:

- Turn handlebars to left.
- Press and hold button **1**.
- » Light is turned off.
- » Steering lock is locked.

Battery of radio-operated key is dead or radio-operated key is lost

- If you lose your keys, refer to the notes regarding the electronic immobilizer ((EWS)).
- If you lose the radio-operated key while riding, you can start the vehicle by using the spare key.
- If the radio-operated key battery is dead, you can start the vehicle simply by inserting the folded-in key into the ring antenna under the vehicle's seat.

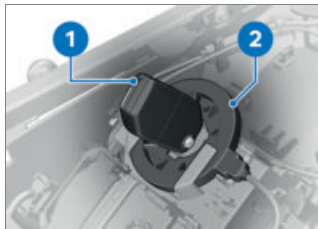

- Remove the seat. (►► 98)

- Insert spare key or the dead, folded-in radio-operated key **1** into the ring antenna **2**.



The spare key or dead, folded-in, radio-operated key must be **inserted** into the opening of the ring antenna.



Period in which the engine must be started.

Then unlocking must be repeated.

30 s

- » Pre-Ride-Check is carried out.
- Key has been detected.
- Engine can be started.
- Start engine. (►► 119)

Replacing the battery of the radio-operated key

If the radio-operated key does not respond when a button is pressed for a short or long time:

- The battery for the radio-operated key no longer has full capacity.



Remote key battery low. Function limited. Change battery.

80 OPERATION

DANGER

Swallowing a battery

Risk of injury or death

- An ignition key contains a button cell as a battery. Batteries or button cells can be swallowed and cause severe or fatal injuries within two hours, e.g. due to internal burns or chemical burns.
- Keep ignition keys and batteries out of the reach (range) of children.
- If it is suspected that a battery or button cell has been swallowed or is inside a body part, seek medical attention immediately.

- Change battery.

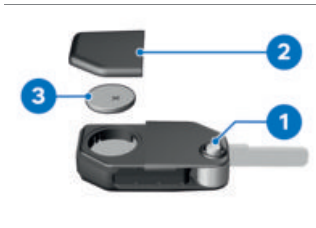

- Press button **1**.
 - » Key bit folds open.
- Press battery cover **2** upward.
- Remove battery **3**.
- Dispose of the old battery in accordance with legal reg-

ulations. Do not dispose of the battery in the household waste.

ATTENTION

Unsuitable or improperly inserted batteries

Component damage

- Use a battery compliant with the manufacturer's specifications.
 - When inserting the battery, make sure that the polarity is correct.
- Insert the new battery with the positive terminal facing up.



Battery type

For Keyless Ride radio-operated key

CR 2032

- Install battery cover **2**.
 - » Red LED in instrument cluster blinks.
 - » The radio-operated key is working again.

ELECTRONIC IMMOBILIZER EWS

The motorcycle's electronics monitor the data stored in the ignition key through a ring antenna incorporated in the ignition lock/wireless lock. The engine control unit does not enable an engine start until the ignition key has been recognized as "authorized" for your motorcycle.

 An additional ignition key attached to the same ring as the ignition key / radio-operated key used to start the engine could "irritate" the electronics, in which case the enabling signal for an engine start is not issued.

Always store further vehicle keys separately from the ignition key / radio-operated key.

If you lose an ignition key, you can have it disabled by your authorized BMW Motorrad dealer. When having a radio-operated key disabled you should also bring all of the motorcycle's remaining keys with you.

The engine can no longer be started using a disabled ignition key; however, a disabled ignition key can be enabled again.

Additional ignition keys can only be obtained from an authorized BMW Motorrad dealer. The keys are part of an integrated safety system, so the dealer is under an obligation to check the legitimacy of all applications for replacement/extra ignition keys.

EMERGENCY-OFF SWITCH



1 Emergency-off switch

WARNING

Operation of the emergency ON/OFF switch when riding

Danger of falling due to blocking of rear wheel

- Do not operate the emergency ON/OFF switch when riding.

The engine can be turned off easily and quickly using the emergency-off switch.

82 OPERATION



- A** Engine turned off
- B** Operating position

INTELLIGENT EMERGENCY CALL

–with intelligent emergency call^{OE}

Emergency call via BMW

Only press the SOS button in an emergency.

Emergency call cannot be ensured if the conditions are unfavorable for technical reasons, e.g. in regions where there is no cellphone reception.

During an emergency call, the position of the vehicle, the selected language and any accident data are transmitted to BMW (► 11). Under unfavorable conditions, data transfer can be limited or delayed. This can lead to delayed processing of the emergency call.

Even if an emergency call via BMW is not possible, a call to a

public emergency call number may be established. This depends on the respective mobile phone network and the national regulations.

Language for emergency call

Depending on the market for which it was determined, each vehicle is assigned a language. The BMW Call Center responds in this language.

 Only your authorized BMW Motorrad dealer is able to change the language for the emergency call. This language assignment to the vehicle differs from the display languages the rider is able to select in the multifunction display.

Manual emergency call Requirement

An emergency has arisen. The vehicle is stationary. The ignition is turned on.



- Open cover **1**.
- Briefly press SOS button **2**.

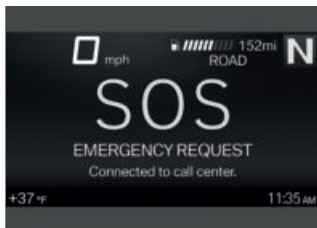

The connection has been established.

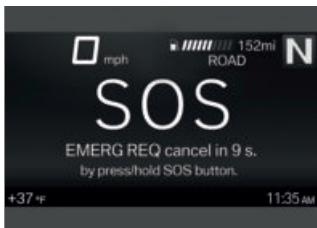

- » The time until an emergency call is placed is displayed. The emergency call can be aborted during this time.
- Cancel emergency call: Press and hold the SOS button **2** for two seconds or turn off the ignition.
- Press the emergency-off switch to stop the engine.
- Remove your helmet.
- » Once the timer has expired, a voice connection will be established with the BMW Call Center.



- Communicate information for the rescue services using the microphone **3** and speakers **4**.

Automatic emergency call

The intelligent emergency call is automatically active once the ignition is switched on and will react if you are involved in a fall.

Emergency call in the event of a minor fall

- A light fall or crash has been detected.
- » An acoustic signal is emitted.

84 OPERATION

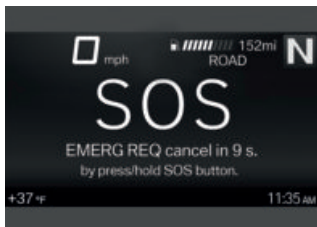

- » The time until an emergency call is placed is displayed. The emergency call can be aborted during this time.
- Cancel emergency call: Press and hold the SOS button for two seconds.
- If possible, remove helmet and stop the engine.
- » Voice contact to the BMW Call Center is established.

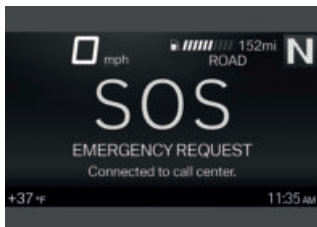

The connection has been established.



- Open cover **1**.
- Communicate information for the rescue services using the microphone **3** and speakers **4**.

Emergency call in the event of a heavy fall

- A heavy fall or crash has been detected.
- » The emergency call is sent automatically without delay.

LIGHTING

Low beams and parking lights

The parking lights turn on automatically when the ignition is turned on.

- The parking lights are a strain on the battery. Only turn on the ignition briefly.

The low beams come on automatically under the following conditions:

- If the engine was started.
- If the vehicle is pushed while the ignition is on.

 With the engine switched off, you can switch on the lights by switching on the high-beam headlight with the ignition switched on or by operating the headlight flasher.

High beams and headlight flasher

- Turn on the ignition. (▣▣▣▶ 76)



- Press switch **1** forward to turn on high beams.
- Pull switch **1** toward rear to actuate headlight flasher.

Headlight courtesy delay feature

- Turn off the ignition.



- Immediately after turning off the ignition, pull switch **1** back and hold until the headlight courtesy delay feature turns on.
- » The vehicle lighting lights up for one minute and then turns off automatically.
- This can be used, for example, to light the path to your front door after the vehicle is parked.

Roadside parking lights

- Turn off the ignition. (▣▣▣▶ 76)



- Immediately after turning off the ignition, push button **1** to the left and hold it until the

86 OPERATION

roadside parking lights turn on.

- Turn ignition on and then off again to turn off the roadside parking lights.

Auxiliary headlights

–with LED additional headlight^{OA}

Requirement

The auxiliary headlights are only active if the low beams are active.

 The auxiliary headlights are permitted as fog lamps and may only be used in poor weather conditions. Comply with the country-specific road traffic regulations.

- Start engine. (▶▶▶ 119)



- Press button **1** to turn on the auxiliary headlights.

 The indicator light for the auxiliary headlight lights up.

- Press button **1** again to turn off the auxiliary headlights.

Operating the hazard warning system

- Turn on the ignition.

 The hazard warning system places a load on the battery. Only switch the hazard warning lights system on briefly.



- Press button **1** to turn on the hazard warning system.
» Ignition can be turned off.
- To turn off the hazard warning system, turn on the ignition as required and press button **1** once again.

Operating turn signals

- Turn on the ignition. (▶▶▶ 76)
- Go to the Settings, Vehicle settings menu, then select the Lights menu item.
- Turn Comfort turn indicator on or off.



- Press button **1** to the left or right to turn on the turn signals.
 - » If the comfort turn signal is turned on, the turn signal automatically switches off once the speed-dependent distance has been covered.
- Alternative: Press button **1** to turn off the turn signals.

TRACTION CONTROL (DTC)

Turning off the DTC

- Turn on the ignition.



The Dynamic Traction Control (DTC) can also be turned off while riding.

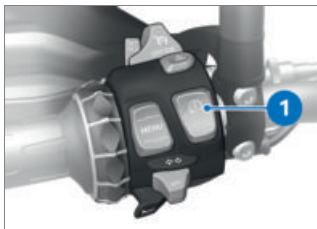

- Press and hold button **1** until the DTC indicator light changes its behavior. Immediately after pressing button **1**, the DTC system status ON is displayed.



lights up.

Possible DTC system status OFF! is displayed.

- Release button **1** after changeover of the status.



continues to light up.

The new DTC system status OFF! is displayed for a short time.

- » The DTC function is switched off.

Turn on the DTC

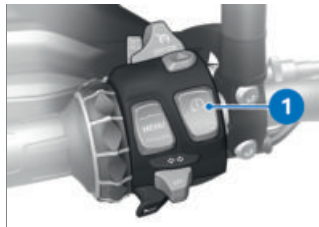

- Press and hold button **1** until the DTC indicator light changes its behavior.

88 OPERATION

Immediately after pressing button **1**, the DTC system status **OFF!** is displayed.

 goes out, and if self-diagnosis has not been completed, it begins to flash.

Possible DTC system status **ON** is displayed.

- Release button **1** after changeover of the status.

 remains off or continues to flash.

The new DTC system status **ON** is displayed for a short time.

- » The DTC function is switched on.
- As an alternative, the ignition can also be turned off and then on again.



If the DTC indicator light lights up after switching the ignition off and on and then continuing to ride at the following minimum speed, a DTC fault has occurred.

min 3 mph (min 5 km/h)

- More detailed information on the Dynamic Traction Control can be found in the "Technology in detail" chapter (➡ 139).

RIDING MODE

Use of the riding modes

BMW Motorrad has developed riding scenarios for your vehicle from which you can select the one matching your situation:

Series

- RAIN: Riding on wet roads.
- ROAD: Riding on dry roads.

–with riding modes Pro^{OE}

With Pro riding modes

- DYNAMIC: Brisk riding on dry roads.
- ENDURO: Driving off-road with road tires.
- ENDURO PRO: riding off-road with coarse-tread off-road tires.

The optimum interaction between engine characteristics, ABS control and DTC control is provided for each of these scenarios.



You can find more detailed information regarding the selectable riding modes in the "Technology in detail" chapter.

Riding mode preselection

–with riding modes Pro^{OE}

With the aid of the riding mode preselection, individually preferred riding modes can be compiled in a preselection.

Two to a maximum of four riding modes can be added to the riding mode preselection.

Factory setting:

RAIN, ROAD, DYNAMIC and ENDURO

Configuring the riding mode preselection

–with riding modes Pro^{OE}

- Turn on the ignition. (▮▮▮ 76)
- Go to menu Settings, Vehicle settings, Riding mode preselection.
- Activate or deactivate riding modes for the riding mode preselection.
 - » The activated riding modes are available for selection.
 - » If fewer than two riding modes are activated, the following message appears:
Action not possible.
Min. number reached.
 - » The compilation of the riding modes in the riding mode preselection is retained, even after the ignition is switched off.

Select riding mode

- Turn on the ignition. (▮▮▮ 76)



- Press button **1**.

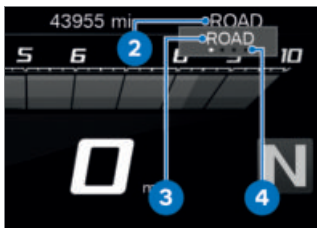

The active riding mode **2** fades into the background and is displayed in pop-up **3**. The guide **4** shows how many riding modes are available.

90 OPERATION



ATTENTION

Turning on off-road mode (ENDURO and ENDURO PRO) when in road mode

Risk of falling due to unstable riding conditions when braking or accelerating in the ABS or DTC control range

- Switch on off-road mode (ENDURO and ENDURO PRO) during off-road riding only.

- Press button **1** repeatedly until the desired riding mode is shown in the pop-up.

—with riding modes Pro^{OE}



Depending on the riding mode or its configuration, the intervention of electronic stability control systems can be restricted.

Possible restrictions are displayed as a pop-up message, e.g. Caution! ABS setting..

The ABS indicator light flashes irregularly.

You can find more detailed information regarding road handling control systems such as ABS in the chapter "Technology in detail".◀

—with riding modes Pro^{OE}

» The availability of the riding modes depends on the individual configuration of the riding mode preselection.◀

» When the vehicle is at a standstill, the selected riding mode is activated after approx. 2 seconds.

» The new riding mode is activated while the vehicle is in motion under the following conditions:

—The throttle grip is in idle position.

—Brake is not engaged.

—Cruise control is deactivated.

» The riding mode selected and its associated engine characteristic ABS and DTC settings are retained even after the ignition has been turned off.

PRO RIDING MODE

–with riding modes Pro^{OE}

Adjustment options

The PRO riding modes can be adjusted individually.

Configuring the riding mode ENDURO PRO

- Turn on the ignition. (▶▶▶ 76)
- Go to menu Settings, Vehicle settings, Riding mode preselection.
- Select and activate ENDURO PRO riding mode.
- Select Configuration and confirm.

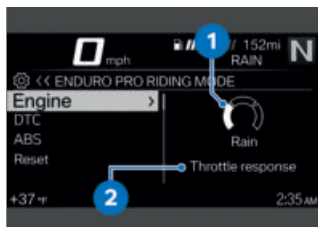

The Engine system is selected. The current setting is displayed as a diagram **1** with explanations of the system **2**.

- Select and confirm the system.



You can browse through the possible settings **3** and the related descriptions **4**.

- Adjust the system.
 - » The Engine, DTC, and ABS systems can all be adjusted in the same way.
- The settings can be reset to factory settings:
- Reset the riding mode settings. (▶▶▶ 91)

Riding mode settings reset

- Configure the ENDURO PRO. (▶▶▶ 91)
- Select Reset and confirm.
 - » The following factory settings apply to ENDURO PRO riding mode:
 - DTC: ROAD
 - ABS: ENDURO PRO
 - Engine: ROAD

92 OPERATION

CRUISE CONTROL

–with cruise control^{OE}

Display while adjusting (Speed Limit Info not active)

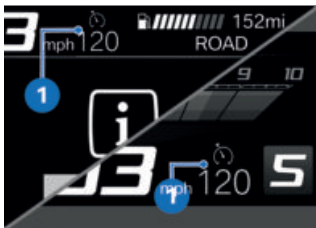

The icon **1** for cruise control is displayed in the Pure Ride view and in the upper status line.

Display while adjusting (Speed Limit Info active)



The icon **1** for cruise control is displayed in the Pure Ride view and in the upper status line.

Turning on cruise control Requirement

Adaptive cruise control only becomes available after changing out of the riding modes Enduro or Enduro Pro.



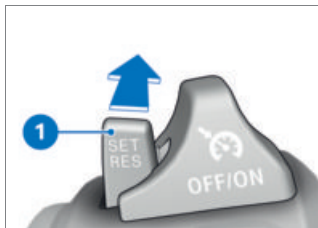

- Slide switch **2** to the right.
» Button **1** can be operated.

Saving the speed



- Briefly press button **1** forward.

 Adjustment range of
 cruise control (gear-dependent)

9...130 mph (15...210 km/h)

 lights up.

- » The vehicle maintains your current cruising speed and the setting is saved.

Accelerating



- Briefly press button **1** forward.
 - » The speed is increased by 1 mph (1.6 km/h) each time the button is pressed.
- Press button **1** forward and hold.
 - » The speed increases continuously.
 - » If button **1** is no longer pressed, the speed reached is maintained and saved.

Decelerating



- Briefly press button **1** backward.
 - » The speed is decreased by 1 mph (1.6 km/h) each time the button is pressed.
- Press button **1** back and hold.
 - » The speed is reduced continuously.
 - » If button **1** is no longer pressed, the speed reached is maintained and saved.

Deactivating cruise control

- Actuate the brakes, coupling or throttle grip (ease the throttle beyond the default setting) to deactivate the adaptive cruise control.
 - » The indicator light for adaptive cruise control extinguishes.

94 OPERATION

Resuming previous cruising speed

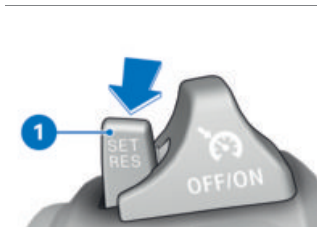

- Briefly push button **1** back to return to the speed saved beforehand.

 Cruise control is not deactivated by accelerating, it only overrules it for a short time. Once the throttle grip is released, the speed falls to the stored value. If further deceleration is desired, the cruise control must be deactivated, e.g. by braking.

 lights up.

Turning off cruise control



- Push switch **2** to the left.
 - » The system is turned off.
 - » Button **1** is locked.

ANTI-THEFT ALARM SYSTEM (DWA)

—with anti-theft alarm system (DWA)^{OE}

Activation

- Turn on the ignition. (▮▮▮ 76)
- Adjust the anti-theft alarm system. (▮▮▮ 97)
- Turn off the ignition.
 - » If DWA is activated, DWA is automatically activated after the ignition is switched off.
 - » Activation takes approximately 30 seconds to complete.
 - » Turn signals flash twice.
 - » Confirmation tone sounds twice (if programmed).
 - » Anti-theft alarm system is active.

–with Keyless Ride^{OE}

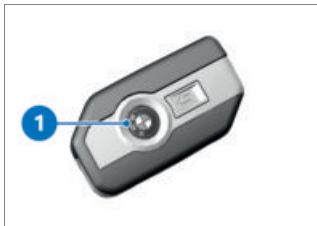

- Turn off the ignition.
- Press button **1** on the radio-operated key twice.
 - » Activation takes approximately 30 seconds to complete.
 - » Turn signals flash twice.
 - » Confirmation tone sounds twice (if programmed).
 - » Anti-theft alarm system is active.



- To deactivate the tilt sensor (for example, if the motorcycle is being transported on a train and the train's strong movements could trigger the alarm signal), press the button **1** on the radio-operated

key again during the activation phase.

- » Turn signals flash three times.
- » Confirmation tone sounds three times (if programmed).
- » Tilt sensor is deactivated.◀

Alarm signal

The DWA alarm signal can be triggered by:

- Motion sensor
- Switch-on attempt with an unauthorized ignition key.
- Disconnection of the DWA from the vehicle battery (DWA battery takes over the power supply – alarm tone only, turn signals do not flash)



If the radio-operated key is within the reception range, any alarm triggered by the tilt alarm sensor is suppressed.

If the DWA battery is discharged, all functions remain operational; the only difference is that the alarm cannot be triggered if the system is disconnected from the vehicle battery.

The duration of the alarm signal is approx. 26 seconds. During the alarm, an alarm tone sounds and the turn signals blink. The type of alarm tone

96 OPERATION

can be set by an authorized BMW Motorrad dealer.

—with Keyless Ride^{OE}



You can cancel a triggered alarm signal at any time by pressing the button **2** of the radio-operated key without deactivating the DWA.

If an alarm signal has been triggered while the motorcycle was unattended, the rider is notified accordingly by an alarm tone sounding once when the ignition is turned on. Then the DWA LED indicates the reason for the alarm signal for one minute.

Light signals on indicator light:

- 1x flash: Movement sensor 1
- 2x flash: Movement sensor 2
- 3 blinks: Ignition is turned on using an unauthorized ignition key

- 4 blinks: Anti-theft alarm system disconnected from vehicle battery
- 5 blinks: Movement sensor 3

Deactivation

- Turn on the ignition. (▣▣▣ 76)
- » Turn signals flash once.
- » Confirmation tone sounds once (if programmed).
- » DWA is turned off.
- with Keyless Ride^{OE}

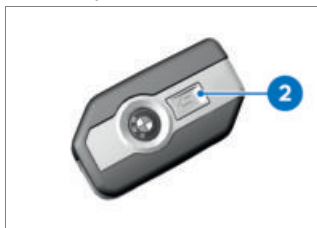

- Press the button **2** on the radio-operated key once.

 If the alarm function is deactivated using the radio-operated key and the ignition is not turned on then, the alarm function will be reactivated automatically after approximately 30 seconds if *Arm automatically* is turned on.

- » Turn signals flash once.
- » Confirmation tone sounds once (if programmed).
- » DWA is turned off.<

Adjusting the anti-theft alarm system

- Turn on the ignition. (▣▣▣ 76)
- Go to menu Settings, Vehicle settings, Alarm system.
- » The following adjustments are available:
 - Adapting Warning signal
 - Turning Tilt sensor on and off
 - Turning Arming tone on and off
 - Turning Arm automatically on and off
- » Possible settings (▣▣▣ 97)

Possible settings

Warning signal: Set increasing and decreasing or intermittent alarm tone.

Tilt sensor: Activate the tilt sensor to monitor the inclination of the vehicle. The anti-theft alarm system responds, for example, in the event of attempted wheel theft or towing away.



Deactivate the tilt sensor when transporting the vehicle to avoid triggering the DWA.

Arming tone: Confirmation alarm tone after activating/deactivating the DWA in addition to flashing turn signals.

Arm automatically: Automatic activation of the alarm function when the ignition is switched off.

Factory settings

The anti-theft alarm system is delivered with the following factory settings:

- Confirmation alarm tone after activation/deactivation of the DWA: no.
- Alarm tone: increasing.

TIRE PRESSURE MONITOR (TPM)

- with tire pressure monitor (TPM)^{OE}
- with riding modes Pro^{OE}

Switching setpoint pressure warning on or off

- When the minimum tire pressure is reached, a target pressure warning can be displayed.
- Go to menu Settings, Vehicle settings, RDC.
- Turn Target pressure warn. on or off.

HEATED GRIPS

Operating heated grips

- Start engine. (▣▣▣ 119)



The heated grips option can only be activated when the engine is running.

98 OPERATION

 The increase in power consumption caused by the heated grips can drain the battery if you are riding at low engine speeds. If the battery is inadequately charged, the heated grips are switched off to ensure starting capability.

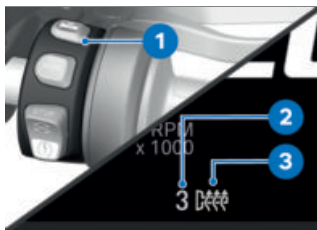

- Press the button **1** repeatedly until the desired heating level **2** is shown in front of the heated grip icon **3**. The handlebar grips can be heated at three different levels. High heater output is used for fast heating of the grips; the switch should then be switched back to a lower heater output.



High heater output



Medium heater output



Low heater output

» If no further changes are made, the selected heating level is set.

- To turn off the heated grip, press button **1** repeatedly until the heated grip icon **3** is not shown anymore in the display.

SEAT

Removing the seat Requirement

Place the motorcycle on its stand on firm, even ground.



- Turn the seat lock **1** to the right with the ignition key.
» Seat bench is unlocked.

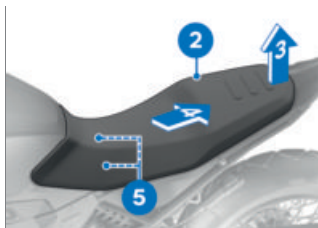

- Detach the seat **2** from the seat lock in the arrow direction **3**.
- Remove the seat from the brackets **5** in the arrow direction **4** and set it on the rubber buffers on a clean surface.

Installing the seat

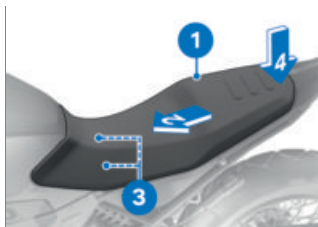

- Push the seat **1** into the holders **3** in the arrow direction **2**.
- Forcibly push the seat in the arrow direction **4**.
- » The seat will audibly engage.

SETTING

06

MIRRORS	102
HEADLIGHTS	102
CLUTCH	103
BRAKES	103
SHIFTING	104
SPRING PRELOAD	104
DAMPING	107

102 SETTING

MIRRORS

Adjusting the mirrors



- Move mirrors into desired position by rotating them.

Adjusting the mirror arm



- Slide the protective cap **1** upwards over the threaded connection on the mirror arm.
- Loosen nut **2**.
- Turn the mirror arm into the desired position.
- Tighten the nut to the specified torque while holding the mirror arm in place.

 Mirror (locknut) on clamping piece

M10 x 1.25

 Mirror (locknut) on clamping piece

16 lb/ft (22 Nm) (Left-hand thread)

- Slide the protective cap over the threaded connection.

HEADLIGHTS

Headlight beam throw and spring preload

The headlight beam throw generally remains constant due to the adjustment of the spring preload to the load status.

Only with a very heavy payload can adjustment of the spring preload be insufficient. If that is the case, the headlight beam throw must be adapted to the weight.

 If there are doubts as to the correct headlight range, have the setting checked by a repair shop, preferably by an authorized BMW Motorrad dealer.

Adjusting the headlight range

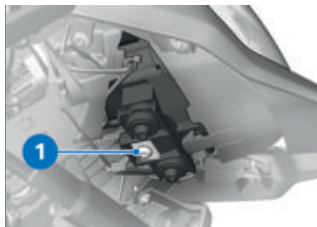

- Loosen the screw **1**.
- Adjust the headlight by tilting slightly.
- Tighten screw **1**.

CLUTCH

Adjusting the clutch lever



WARNING

Adjusting the clutch lever while driving

Accident hazard

- Adjust the clutch lever when the motorcycle is stationary.

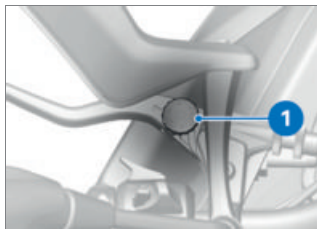

- Turn the adjustment screw **1** clockwise to increase the

distance between the clutch lever and handlebar grip.

- Turn the adjustment screw **1** counterclockwise to decrease the distance between the clutch lever and handlebar grip.



The adjusting screw is easier to turn when the clutch lever is pressed forward.

BRAKES

Adjusting the brake lever



WARNING

Modified position of the brake fluid reservoir

Air in the brake system

- Do not twist the handlebar fitting or the handlebars.



WARNING

Adjusting the brake lever while driving

Risk of accident

- Only adjust the brake lever when the vehicle is stationary.

104 SETTING

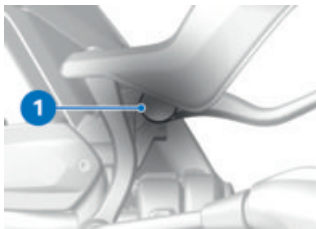

- Turn the adjustment screw **1** counterclockwise to increase the distance between the brake lever and handlebar grip.
 - Turn the adjustment screw **1** clockwise to decrease the distance between the brake lever and handlebar grip.
-  The adjustment screw is easier to turn when the brake lever is pressed forward.

SHIFTING

Adjusting the gearshift lever

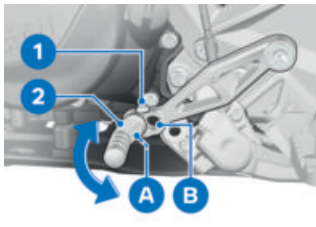

- Loosen screw **1**.
- Install the foot plate **2** in the mount **A** or **B** as desired.

- Turn the foot plate **2** to the desired position.

 If the toe piece is set too high or too low, this can cause problems when shifting gears. In the event of shifting problems, check the toe piece setting.

- Tighten screw **1** to the specified torque.



Foot piece to gearshift lever

M6 x 25

6 lb/ft (8 Nm)

SPRING PRELOAD

Setting

The spring preload on the front wheel must be adapted to the weight of the rider. Higher weight requires a higher spring preload, lower weight requires a lower spring preload.

It is essential to set the spring preload at the rear wheel to suit the load carried by the motorcycle. Increase spring preload if the payload increases and reduce spring preload accordingly if the payload decreases.

Adjusting the spring preload on the front wheel

—without lowered^{OE}

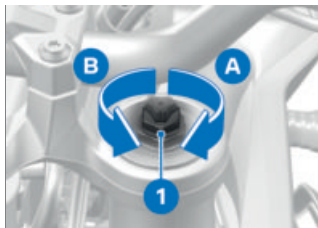

WARNING

Settings for spring preload and front fork damping that have not been coordinated.

Worse handling.

- Adapt the front fork damping to the spring preload.
 - To reduce the compression (increase the spring preload), turn the adjustment screw **1** in direction **A** using a tool from the onboard tool kit.
 - To increase the spring compression (reduce the spring preload), turn the adjustment screw **1** in direction **B** using a tool from the onboard tool kit.
-  Set the same spring preload at both fork legs.

Adjusting the spring preload at the rear wheel

- Remove the seat. (→ 98)
- Remove the onboard vehicle tool kit.

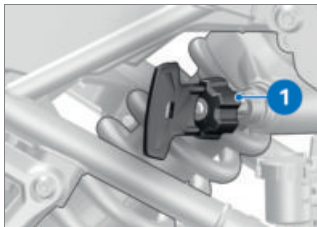

WARNING

Settings for spring preload and spring strut damping that have not been coordinated.

Worse handling.

- Adapt the spring strut damping to the spring preload.
- To increase the spring preload, turn the adjustment wheel **1** clockwise using the onboard toolkit.
- To reduce the spring preload, turn the adjustment wheel **1** counterclockwise using the onboard toolkit.

106 SETTING



Basic setting of spring preload, rear

Turn the adjustment wheel counterclockwise up to the stop (One-up without load)

Turn the adjustment wheel counterclockwise up to the stop, then 10 turns clockwise (One-up with load)

Turn the adjustment wheel clockwise up to the stop (Two-up mode with load)

- Refit the onboard vehicle tool kit.
- Install the seat. (▶▶ 99)

—with^{OE} enduro package Pro



WARNING

Settings for spring preload and spring strut damping that have not been coordinated.

Worse handling.

- Adapt the spring strut damping to the spring preload.
- To increase spring preload, turn adjustment wheel **1** clockwise.
- To decrease spring preload, turn adjustment wheel **1** counterclockwise.



Basic setting of spring preload, rear

Turn the adjustment wheel counterclockwise up to the stop (One-up without load)



Basic setting of spring preload, rear

Turn the adjustment wheel counterclockwise up to the stop, then 10 turns clockwise (One-up with load)

Turn the adjustment wheel clockwise up to the stop (Two-up mode with load)◀

DAMPING

Setting

Damping must be adjusted to the road condition and the spring preload.

- A rough road requires softer damping than a smooth road.
- An increase in spring preload requires firmer damping, a reduction in spring preload requires softer damping.

Adjusting the compression damping on the front wheel

-without lowered^{OE}



- Adjust compression damping with adjustment screw **1** on the left-side fork leg.
- For increasing the damping: Turn the adjustment screw **1** clockwise.
- For reducing the damping: Turn the adjustment screw **1** counterclockwise.



Compression stage, basic setting, front

Turn the adjustment screw clockwise up to the stop, then turn it back 10 clicks

Adjusting the rebound-stage damping on the front wheel

-without lowered^{OE}

108 SETTING

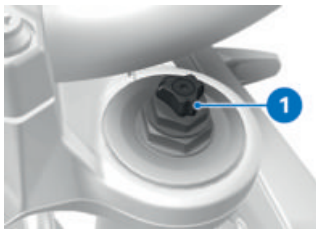

- Adjust rebound-stage damping by means of the adjustment screw **1** on the right-side fork leg.
- For increasing the damping: Turn the adjustment screw **1** clockwise.
- For reducing the damping: Turn the adjustment screw **1** counterclockwise.



Rebound stage, basic setting, front

Turn the adjustment screw clockwise up to the stop, then turn it back 10 clicks

Adjusting damping at the rear wheel

- Park the motorcycle, making sure the ground is level and firm.

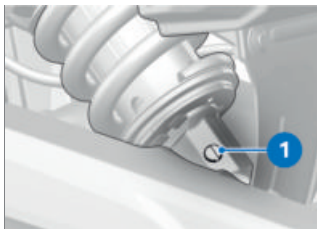

- Adjust damping via the adjustment screw **1**.

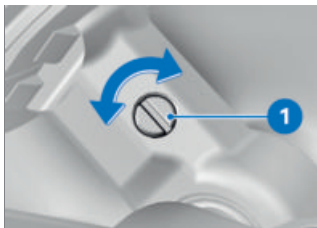

- To increase damping, turn the adjustment screw **1** clockwise.
- To reduce damping, turn the adjustment screw **1** counterclockwise.



Basic setting of rear wheel damping

187 lbs (85 kg) (Full tank of gas, with rider)

Turn adjusting screw as far as possible clockwise, then turn back 1.5 turns. (One-up without load)



Basic setting of rear wheel damping

Turn adjusting screw clockwise up to the stop, then turn back by 0.5 turns. (One-up with load)

Turn adjusting screw clockwise up to the stop, then turn back by 0.25 turns. (Two-up mode with load)



Spring strut rebound basic setting

Turn the adjustment screw clockwise up to the stop, then turn it back 5 clicks. (One-up with load)

Turn the adjustment screw clockwise up to the stop, then turn it back 2 clicks. (Two-up mode with load)◀

–with^{OE} enduro package Pro



- Adjust rebound-stage damping using adjustment screw **1**.
- To increase the rebound-stage damping, turn the adjustment screw **1** clockwise.
- To reduce the rebound-stage damping, turn the adjustment screw **1** counterclockwise.



Spring strut rebound basic setting

Turn the adjustment screw clockwise up to the stop, then turn it back 8 clicks. (One-up without load)

Adjusting the compression damping on rear wheel

–with^{OE} enduro package Pro

- Park the motorcycle, making sure the ground is level and firm.

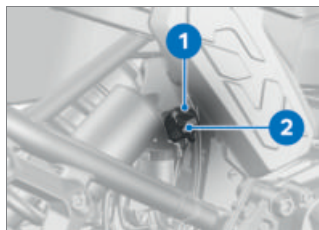

- Use the adjustment screw **1** to set the compression damping to high-speed.
- Use the adjustment screw **2** to set the compression damping to low-speed.

110 SETTING

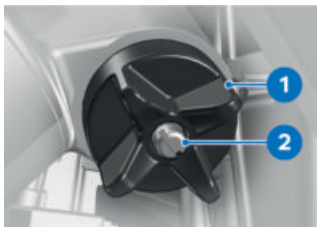

- To increase the high-speed compression damping: Turn the adjustment screw **1** clockwise.
- To decrease the high-speed compression damping: Turn the adjustment screw **1** counterclockwise.
- To increase the low-speed compression damping: Turn the adjustment screw **2** clockwise.
- To decrease the low-speed compression damping: Turn the adjustment screw **2** counterclockwise.



Compression stage, basic setting, rear

187 lbs (85 kg) (Full tank of gas, with rider)

Turn the high-speed compression stage adjustment screw clockwise up to the stop, then turn it back 11 clicks. (One-up without load)



Compression stage, basic setting, rear

Turn the high-speed compression stage adjustment screw clockwise up to the stop, then turn it back 5 clicks. (One-up with load)

Turn the high-speed compression stage adjustment screw clockwise up to the stop, then turn it back 2 clicks. (Two-up mode with load)

Turn the low-speed compression stage adjustment screw clockwise up to the stop, then turn it back 12 clicks. (One-up without load)

Turn the low-speed compression stage adjustment screw clockwise up to the stop, then turn it back 5 clicks. (One-up with load)

Turn the low-speed compression stage adjustment screw clockwise up to the stop, then turn it back 2 clicks. (Two-up mode with load)

RIDING

07

SAFETY INSTRUCTIONS	114
REGULAR CHECK	118
STARTING	119
BREAKING IN	122
SHIFTING	123
OFF-ROAD USE	124
BRAKES	125
PARKING THE MOTORCYCLE	127
REFUELING	128
FASTENING MOTORCYCLE IN PLACE FOR TRANS- PORTATION	133

SAFETY INSTRUCTIONS

Rider's equipment

Do not ride without the correct clothing! Always wear

- Helmet
- Rider's suit
- Gloves
- Boots

This applies even to short journeys, and to every season of the year. Your authorized BMW Motorrad dealer will be happy to advise you and has the correct clothing for every purpose.



WARNING

Seizure of loose textile fabrics, luggage items or straps in open running rotating vehicle parts (wheels, prop shaft)

Risk of accident

- Make sure that no loosely worn textile fabrics can get caught in open, running and rotating vehicle parts.
- Keep luggage items as well as tension belts and lashing straps away from open, running and rotating vehicle parts.

Reduced clearance in inclined position

-with lowered^{OE}

Motorcycles with lowered chassis have a reduced ground clearance in angular position and to the ground compared to motorcycles with a standard chassis (see chapter Technical data).



WARNING

When cornering with lowered motorcycles, motorcycle parts can contact the road surface sooner than normal.

Accident hazard

- Carefully test the clearance of the motorcycle in an inclined position and adjust your riding style accordingly.

Test the clearance of your motorcycle at an angle in safe situations. Remember to take the limited ground clearance of your vehicle into account when riding over curbs and similar obstacles.

Lowering the motorcycle reduces the spring travel. This may result in reduction of the usual driving comfort. Especially in two-up mode, the spring preload should be adjusted accordingly.

Correct loading



WARNING

Reduced riding stability caused by overloading and uneven loading

Accident hazard

- Do not exceed the gross weight limit and observe the loading information.
 - Adjust the setting of the spring preload and damping for the current gross vehicle weight.
- with case^{OA}
- Ensure that case volumes on left and right are equal.
 - Make sure that weight is uniformly distributed between right and left.
 - Pack heavy luggage items to the bottom and center of cases.
 - Observe the maximum payload and maximum speed; also see the Accessories chapter (198).



Payload per case

max 18 lbs (max 8 kg)



Maximum speed for riding with case

max 99 mph (max 160 km/h)◀

—with tank bag^{OA}

- Observe the maximum payload of the tank bag.



Payload of tank rucksack

max 11 lbs (max 5 kg)



Maximum speed when riding with loaded tank bag

max 81 mph (max 130 km/h)◀

—with rear bag^{OA}

- Observe maximum payload of the rear bag.



Payload of rear bag

max 11 lbs (max 5 kg)



Maximum speed when riding with loaded rear bag

max 81 mph (max 130 km/h)◀

116 RIDING

–with single seat, black^{OA}

- Maximum payload of the cover



Maximum payload of the cover

11 lbs (5 kg)◁

Speed

If you ride at high speed, always bear in mind that various boundary conditions can negatively affect the vehicle handling of your motorcycle. These include, but are not limited to, the following:

- Incorrect settings of spring-strut and shock absorber system
- Unevenly distributed load
- Loose clothing
- Insufficient tire pressure
- Tire tread in poor condition
- Installed luggage systems, such as cases, topcases and tank rucksacks.

Maximum speed with studded or winter tires



DANGER

Maximum speed of the motorcycle is higher than the permissible maximum speed of the tires

Risk of accident due to tire damage at high speed

- Observe the maximum speed applicable to the tires.

With studded or winter tires, the maximum speed permitted for the tires must be observed. Attach a sticker specifying the maximum speed permitted within the field of view of the instrument cluster.

Risk of poisoning

Exhaust gas contains carbon monoxide, which is colorless and odorless but highly toxic.



WARNING

Harmful exhaust gas

Danger of suffocation

- Do not inhale exhaust fumes.
- Do not run the engine in closed rooms.

**WARNING****Inhalation of vapors that are harmful to health**

Damage to health

- Do not inhale vapors from operating fluids and plastics.
- Only use the vehicle outdoors.

Burn hazard**CAUTION****Intense heating up of engine and exhaust system while riding**

Burn hazard

- After parking the motorcycle, make sure that no persons or objects come into contact with the engine and exhaust system.

**WARNING****Opening the radiator cap**

Risk of burning

- Do not open the radiator cap when it is hot.
- Check the coolant level exclusively at the expansion tank and top up if necessary.

Catalytic converter

If misfiring causes unburned fuel to enter the catalytic converter, there is a danger of overheating and damage.

The following must be observed:

- Do not run the fuel tank dry
- Do not run the engine with the spark-plug cap removed
- Stop the engine immediately if it misfires
- Use unleaded fuel only
- Comply with all specified maintenance intervals.

**ATTENTION****Unburned fuel in the catalytic converter**

Damage to catalytic converter

- Note the points listed for protection of the catalytic converter.

Danger of overheating



ATTENTION

Engine idling for a lengthy period while at a standstill

Overheating due to insufficient cooling; in extreme cases vehicle fire

- Do not allow the engine to idle unnecessarily.
- After starting, ride off immediately.

Modifications



ATTENTION

Modifications to the motorcycle (e.g. engine control unit, throttle valves, clutch)

Damage to the affected parts, failure of safety-relevant functions, expiration of warranty

- Do not make any modifications.

REGULAR CHECK

Checklist

- Use the following checklist to check your motorcycle at regular intervals.

In the event of a change to the load status:

- Adjust the spring preload at the rear wheel. (▣▣▣ 105)
- Adjust damping at the rear wheel. (▣▣▣ 108)

Before every ride:

- Check operation of the brake system.
- Check operation of the lighting and signal system.
- Check the clutch cable for damage.
- Check the clutch function. (▣▣▣ 159)
- Check tire tread depth. (▣▣▣ 163)
- Check tire pressure. (▣▣▣ 162)
- Check that the case and luggage are firmly secured.

At every 3rd Refueling stop:

- Check engine oil level. (▣▣▣ 152)
- Check front brake pad thickness. (▣▣▣ 155)
- Check rear brake pad thickness. (▣▣▣ 156)
- Check the front brake fluid level. (▣▣▣ 157)
- Check rear brake fluid level. (▣▣▣ 158)
- Check the coolant level. (▣▣▣ 160)
- Lubricate the chain. (▣▣▣ 175)
- Check chain tension. (▣▣▣ 176)

STARTING

Starting the engine



ATTENTION

Sufficient transmission gear-box lubrication only when the engine is running.

Transmission damage

- Do not allow the motorcycle to roll for longer periods or push it over longer distances with the engine switched off.

- Turn on the ignition. (▮▮▮ 76)
 - » Pre-Ride-Check is carried out. (▮▮▮ 119)
 - » ABS self-diagnosis is performed. (▮▮▮ 120)
 - » DTC self-diagnosis is performed. (▮▮▮ 121)
- Engage Neutral, or pull back the clutch lever if a gear is engaged.

 You cannot start the motorcycle with the side stand extended and a gear engaged. The engine will switch itself off if it is started with the transmission in neutral and then a gear is engaged before retracting the side stand.



- Press starter button **1**.

 The starting attempt is automatically interrupted if battery voltage is too low. Recharge the battery before you attempt to start the engine again, or use jumper cables and a donor battery to start. For more details, see the "maintenance" chapter under "Jump starting".



Engine starts.

- » If the engine fails to start, the troubleshooting chart in the Technical Data chapter may provide assistance. (▮▮▮ 212)

Pre-Ride-Check

After the ignition is turned on, the instrument cluster performs a test of the indicator and warning lights – what we call the "Pre-Ride-Check". Starting the engine before the test is completed will cancel the remainder of the test.

120 RIDING

Phase 1

All indicator and warning lights are turned on.

After a longer standstill of the vehicle, an animation is displayed during the system start.

Phase 2

The general warning light changes from red to yellow.

Phase 3

All of the indicator and warning lights that have been turned on are turned off in reverse order.

If one of the indicator and warning lights was not turned on:

- Have the malfunction corrected as soon as possible at a repair shop, preferably an authorized BMW Motorrad dealer.

–with riding modes Pro^{OE}

 Depending on the riding mode or its configuration, the intervention of electronic stability control systems can be restricted.

Possible restrictions are displayed as a pop-up message, e.g. Caution! ABS setting..

The ABS indicator light flashes irregularly.

You can find more detailed information regarding road handling control systems such as ABS in the chapter "Technology in detail".<

ABS self-diagnosis

The self-diagnosis routine is determining whether BMW Motorrad ABS is ready for operation. The self-diagnosis routine launches automatically when you start the ignition.

Phase 1

» Check on system components monitored by diagnostic system while motorcycle is parked.



ABS indicator and warning light flashes.

Phase 2

» Check wheel speed sensors while starting off.



ABS indicator and warning light flashes.

ABS self-diagnosis completed

» The ABS indicator and warning light goes out.



ABS self-diagnosis not completed

ABS is not available, as the self-diagnosis routine was not completed. (The motor-cycle must reach a specified minimum speed before the system can check operation of the wheel speed sensors: 3 mph (5 km/h))

If an ABS error is displayed after the ABS self-diagnosis is completed:

- You may continue riding. It must be noted that the ABS function is not available.
- Have the malfunction corrected as soon as possible at a specialist workshop, preferably an authorized BMW Motorrad retailer.

DTC self-diagnosis

The self-diagnosis routine is determining whether BMW Motorrad DTC is ready for operation. The self-diagnosis runs automatically when you switch on the ignition.

Phase 1

» Checking system components capable of diagnosis while vehicle is at a standstill.



flashes slowly.

Phase 2

» Checking system components capable of diagnosis while riding off.



flashes slowly.

DTC self-diagnosis completed

» The DTC symbol is no longer displayed.

- Check the display of all indicator and warning lights.



DTC self-diagnosis not completed

The DTC function is not available, as the self-diagnosis function has not been completed. (To check wheel speed sensors, motorcycle must reach a minimum speed with engine running: min 3 mph (min 5 km/h))

If a DTC fault is displayed after the DTC self-diagnosis is completed:

- You may continue riding. Please note that the DTC function is restricted or is not available at all.
- Have the malfunction corrected as soon as possible at a specialist workshop,

122 RIDING

preferably an authorized BMW Motorrad retailer.

BREAKING IN

Engine

- In the period preceding the break-in service, ride in frequently changing engine load and engine speed ranges, avoiding extended periods at constant rpm.
- Try to do most of your riding during this initial period on twisting, fairly hilly roads, avoiding highways if possible.
- Observe the engine run-in speeds.



Engine run-in speed

<6500 min⁻¹ (Odometer reading 0...746 miles (0...1200 km))

No full throttle (Odometer reading 0...746 miles (0...1200 km))

- Observe mileage, after which the break-in inspection should be performed.



Mileage until first run-in check

311...746 miles (500...1200 km)

Brake pads

New brake pads have to be broken in before they can achieve their optimum frictional force. This reduction in braking effect can be compensated for by exerting greater pressure on the brake levers.



WARNING

New brake pads

Extension of the braking distance, accident hazard

- Brake early.

Tires

New tires have a smooth surface. They must be roughened by riding in a restrained manner at varying lean angles until the tires are run in. This running in procedure is essential if the tire tread is to achieve maximum grip.



WARNING

Loss of adhesion of new tires on wet roads and at extreme angles

Accident hazard

- Always think well ahead and avoid extreme angles.

SHIFTING

–with Gearshift Assistant Pro^{OE}

Gear Shift Assistant Pro

 When downshifting using the Pro Gear Shift Assistant, the cruise control is automatically deactivated for safety reasons. During upshifting, the cruise control remains active.



- Engage the gears as usual with the foot-operated gearshift lever.
- » The Gear Shift Assistant provides assistance for upshifts and downshifts, without the rider having to actuate the clutch or throttle grip.
- This is not an automatic gearshift system.
- The rider is an essential part of the system and decides when to shift gears.
- The sensor **1** on the gearshift shaft detects the intent to shift gears and triggers the shift assistance.
- » If you are riding at a constant speed in a low gear at high RPMs and attempt to shift gears without clutch control, it can cause a strong load-change response.
- BMW Motorrad recommends only shifting gears with clutch control in these riding situations.
- Use of the Pro Gear Shift Assistant should be avoided at RPMs within the speed limiter range.
- » Shift assistance is not available in the following situations:
 - With clutch actuated.
 - Gearshift lever not in its initial position
 - When upshifting with the throttle valve closed (coasting overrun) or when decelerating.
 - When downshifting with the throttle valve open or when accelerating.
- After a gearshift, you must fully release the gearshift lever before another gear shift with the Gear Shift Assistant Pro can take place. More detailed information on the Gearshift Assistant Pro (▶▶ 146).

OFF-ROAD USE

After riding off-road

BMW Motorrad recommends that the following be observed after driving off-road:

Tire pressure

WARNING

When driving off-road, lower tire pressure than riding on paved roads

Risk of accident due to poorer handling characteristics.

- Ensure proper tire inflation pressure.

Brakes

WARNING

Riding on unpaved or dirty roads

Delayed braking effect due to dirty brake discs and brake pads

- Brake early until the brakes are clean again.

ATTENTION

Riding on unpaved or dirty roads

Increased brake pad wear

- Check the brake pad thickness more often and replace the brake pads sooner.

Spring preload and damping

WARNING

Modified values for spring preload and spring strut damping when riding off-road

Poorer handling characteristics on paved roads

- Set correct spring preload and correct spring strut damping before leaving off-road terrain.

Rims

BMW Motorrad recommends checking the rims for possible damage after riding off-road.

Air cleaner element



ATTENTION

Dirty air filter element

Engine damage

- When driving in dusty terrain, check air filter insert for soiling at short intervals and clean or replace if necessary.

Use under very dusty conditions (deserts, savannas, etc.) requires the use of air filter elements specially developed for these kinds of applications.

BRAKES

How do you achieve the shortest braking distance?

The dynamic load distribution between the front and rear wheel changes during braking. The heavier you brake, the greater the weight transfer to the front wheel. Increases in the load on an individual wheel are accompanied by a rise in the effective braking force that the wheel can provide.

To achieve the shortest possible braking distance, the front wheel brake must be applied quickly and with progressively greater levels of force. This procedure provides ideal exploitation of the extra weight

transfer to the front wheel. The clutch should also be disengaged at the same time. With the frequently instructed "emergency braking," in which the brake pressure is generated as quickly as possible and with great force, dynamic load distribution lags behind the progressive increases in deceleration rate and the braking force cannot be completely transferred to the road. The front wheel can lock up. Locking up of the front wheel is prevented by BMW Motorrad ABS.

Descending mountain passes



WARNING

Braking should be done predominantly using the rear wheel brake when riding on downhill routes

Loss of braking effect, destruction of the brakes due to overheating

- Apply the front and rear wheel brake and use the engine brake.

Wet, soiled brakes



WARNING

Decreased braking effect due to moisture and dirt

Risk of accident

- Dry brakes or clean them through braking; if necessary, clean them manually.
- Brake early until the tires have reached their full braking effect again.

Moisture and dirt on the brake discs and the brake pads result in a decrease in the braking effect.

Delayed or decreased braking effect must be expected in the following situations:

- When riding in the rain and through puddles.
- After washing the vehicle.
- When riding on salted roads.
- After working on the brakes due to oil or grease residues.
- When riding on soiled roads or offroad.

ABS Pro

Physical riding limits



WARNING

Braking in curves

Danger of falling despite ABS Pro

- The rider is always responsible for adapting his/her driving style.
- Do not reduce the system's extra safety margin with careless riding or unnecessary risks.

ABS Pro is available in all riding modes except for Enduro PRO.

Falling cannot be excluded

Although ABS Pro represents valuable support and an enormous safety advantage for the rider when braking in the inclined position, it by no means redefines the physical riding limits. It is still possible to exceed those limits through misjudgments or riding errors. In extreme cases this may result in a fall.

Use on public roads

ABS Pro helps make riding your motorcycle on public roads even safer. When braking due to unexpected hazards in curves, locking-up

and slipping of the wheels is prevented within the scope of the physical riding limits.

 ABS Pro was not developed to increase the individual braking performance in the inclined position.

PARKING THE MOTORCYCLE

Side stand

- Turn off engine.



ATTENTION

Poor ground conditions in area of stand

Component damage cause by tipping over

- Always check that the ground under the stand is level and firm.



ATTENTION

Loading of the side stand with additional weight

Component damage cause by tipping over

- Do not sit on the motorcycle when it is parked on the side stands.

- Fold out side stand and park motorcycle.
- If the slope of the road permits, turn the handlebars to the left.

- On slopes point the motorcycle uphill and engage 1st gear.

Center stand

–with center stand^{OA}

- Turn off engine.



ATTENTION

Poor ground conditions in area of stand

Component damage cause by tipping over

- Always check that the ground under the stand is level and firm.



ATTENTION

Folding in the center stand in case of strong movements

Component damage cause by tipping over

- Do not sit on the vehicle while it is resting on the center stand.

- Fold down center stand and prop up motorcycle.

REFUELING

Fuel quality

Requirement

For optimal fuel consumption, the fuel should be sulfur-free or very low in sulfur content.



ATTENTION

Refueling with leaded fuel

Damage to catalytic converter

- Do not refuel with leaded gasoline or gasoline with metallic additives, e.g. manganese or iron.



ATTENTION

Use of Ethanol E85 as fuel

Damage to the engine and fuel supply

- Do not refuel with E85, i.e. fuel with an ethanol content of 85 %, or with Flex Fuel.
- Observe the maximum ethanol content of the fuel.



Fuel additives clean the fuel injection system and the combustion area. Fuel additives should be used when refueling with low-quality fuels or during longer stationary periods. Your authorized BMW Motorrad dealer can pro-

vide you with more detailed information.



Recommended fuel quality

Premium unleaded (max 15% ethanol, E10/E15)
89 AKI (95 ROZ/RON)
90 AKI



Alternative fuel quality

Regular unleaded (restrictions with regard to power and fuel consumption.) (max 15% ethanol, E10/E15)
87 AKI (91 ROZ/RON)
87 AKI

Refueling procedure



WARNING

Fuel is highly flammable

Fire and explosion hazard

- Do not smoke. Never bring a naked flame near the fuel tank.



WARNING

Escaping of fuel due to expansion under exposure to heat with overfilled fuel tank

Accident hazard

- Do not overfill the fuel tank.

ATTENTION

Contact of fuel and plastic surfaces

Damage to surfaces (become unattractive or cloudy)

- Immediately clean plastic surfaces after contact with fuel.

- Put the motorcycle up on the side stand, ensuring that it is resting on a firm and level support surface.
–with center stand^{OA}
- Make sure the ground is level and firm and put the motorcycle on its center stand.<

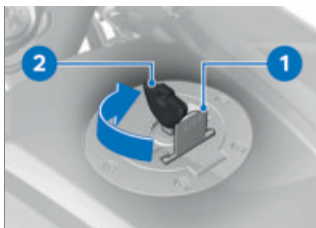

- Open the protective flap **1**.
- Unlock the cap **2** of the fuel tank with the ignition key clockwise and open.



- Refuel up to the lower edge of the fuel filler neck, but no higher. This is the maximum level.

 If refueling is carried out after running on fuel reserve, the resulting filling capacity must be greater than the fuel reserve so that the new fill level is detected and the fuel reserve indicator light is switched off.

 The "usable fuel quantity" specified in the technical data is the fuel quantity, which can be refueled if the fuel tank was completely emptied, i.e., if the engine dies off due to lack of fuel.



Usable fuel quantity

Approx. 3.8 gal (Approx. 14.5 l)

130 RIDING



Reserve fuel quantity

Approx. 1.1 gal (Approx. 4 l)

- Press the fuel tank cap down firmly to lock it.
- Remove the ignition key and close the protective flap.

Refueling procedure

—with Keyless Ride^{OE}

Requirement

Steering lock is unlocked.



WARNING

Fuel is highly flammable

Fire and explosion hazard

- Do not smoke. Never bring a naked flame near the fuel tank.



WARNING

Escaping of fuel due to expansion under exposure to heat with overfilled fuel tank

Accident hazard

- Do not overfill the fuel tank.



ATTENTION

Contact of fuel and plastic surfaces

Damage to surfaces (become unattractive or cloudy)

- Immediately clean plastic surfaces after contact with fuel.

- Put the motorcycle up on the side stand, ensuring that it is resting on a firm and level support surface.
—with center stand^{OA}
- Make sure the ground is level and firm and put the motorcycle on its center stand.◁
- with Keyless Ride^{OE}
- Turn off the ignition. (▶▶▶ 78)



After the ignition is switched off, the fuel filler cap can be opened within the specified run-on time even without the radio-operated key being within the reception area.



After-running period for opening the fuel filler cap

2 min

- » There are **2 ways** to open the fuel filler cap:
- Within the after-run period.
 - After the after-run period is over.

Version 1

—with Keyless Ride^{OE}

Requirement

Within the after-run period

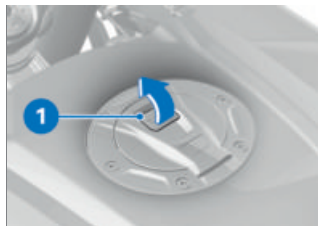

- Slowly pull up the fuel cap tab **1**.
- » Fuel filler cap unlocked.
- Open fuel filler cap completely.

Version 2

—with Keyless Ride^{OE}

Requirement

After the after-run period is over

- Bring radio-operated key into reception range.
- Slowly pull up tab **1**.
- » The indicator light for the radio-operated key blinks as long as the radio-operated key is being searched for.
- Slowly pull up the fuel cap tab **1** again.
- » Fuel filler cap unlocked.

- Open fuel filler cap completely.



- Refuel with a fuel quality as specified above, but no higher than the lower edge of the fuel filler neck. This is the maximum level.

 If refueling is carried out after running on fuel reserve, the resulting filling capacity must be greater than the fuel reserve so that the new fill level is detected and the fuel reserve indicator light is switched off.

 The "usable fuel quantity" specified in the technical data is the fuel quantity, which can be refueled if the fuel tank was completely emptied, i.e., if the engine dies off due to lack of fuel.

132 RIDING



Usable fuel quantity

Approx. 3.8 gal (Approx. 14.5 l)



Reserve fuel quantity

Approx. 1.1 gal (Approx. 4 l)

- Press fuel filler cap of fuel tank down firmly.
 - » Fuel filler cap snaps in audibly.
 - » The fuel cap automatically locks after the after-run period is over.
 - » The engaged fuel cap snaps in immediately when the steering lock is locked or the ignition is turned on.

Open fuel filler cap emergency release

—with Keyless Ride^{OE}

The fuel filler cap cannot be opened.

- Have the fault rectified as soon as possible by a repair shop, preferably an authorized BMW Motorrad dealer.



- Remove screws **1**.
- Remove emergency release **2**.
 - » Fuel filler cap unlocked.
- Open fuel filler cap completely.
- Refueling. (►► 130)
- Close fuel filler cap emergency release. (►► 132)

Close fuel filler cap emergency unlocking

—with Keyless Ride^{OE}

Requirement

Fuel filler cap is closed.



- Position the emergency unlocking **2**.
- Install screws **1**.

FASTENING MOTORCYCLE IN PLACE FOR TRANSPORTATION

- Make sure that all components that might come into contact with luggage straps are adequately protected against scratching. Use adhesive tape or soft cloths, for example, for this purpose.



ATTENTION

Motorcycle tips to the side when raising

Component damage cause by tipping over

- Secure the motorcycle against tipping to the side, preferably with the assistance of a second person.
- Push the motorcycle onto the transportation flat and hold it in position; do not place it on the side stand or center stand.



ATTENTION

Pinching of components

Component damage

- Do not pinch components, e.g. brake lines or wiring harnesses.
 - Fasten the front luggage straps on both sides on the lower fork bridge and tighten them.
- 
- Fasten the rear tensioning belts on both sides on the rear frame and tighten them.
 - Tighten all tensioning belts evenly.

TECHNOLOGY IN DETAIL

08

GENERAL NOTES	136
ANTILOCK BRAKING SYSTEM (ABS)	136
TRACTION CONTROL (DTC)	139
ENGINE DRAG TORQUE CONTROL	141
RIDING MODE	142
DYNAMIC BRAKE CONTROL	144
TIRE PRESSURE MONITOR (RDC)	144
GEAR SHIFT ASSISTANT	146

GENERAL NOTES

More information on the topic of technology is available at bmw-motorrad.com/technik.

ANTILOCK BRAKING SYSTEM (ABS)

How does ABS work?

The maximum braking force that can be transferred to the road is partially dependent on the coefficient of friction of the road. Gravel, ice, snow and wet roads offer a considerably poorer friction coefficient than a dry, clean asphalt surface. The poorer the coefficient of friction of the road is, the longer the braking distance will be.

If the maximum transferable braking force is exceeded when the rider increases the brake pressure, the wheels begin to lock and riding stability is lost, and a fall can result. Before this situation occurs, ABS intervenes and adjusts the brake pressure to the maximum transferable braking force. This enables the wheels to continue to turn and maintains riding stability regardless of the road condition.

What happens when rough roads are encountered?

Bumpy or rough roads can briefly lead to a loss of contact between the tires and the road surface, until the transferable braking force is reduced to zero. If the brakes are applied in this situation, the ABS must reduce the brake pressure to ensure riding stability when contact to the road is restored. At this point, the BMW Motorrad ABS must assume extremely low coefficients of friction (gravel, ice, snow) so that the running wheels turn in every imaginable case and the riding stability is ensured. After detecting the actual conditions, the system adjusts the optimum brake pressure.

Lifting off rear wheel

During extremely heavy and rapid decelerations, however, it is possible under certain circumstances that the BMW Motorrad Antilock Brake System cannot prevent the rear wheel from lifting off the ground. In these cases, the motorcycle can also flip end over end.

**WARNING****Lifting off of the rear wheel due to heavy braking**

Accident hazard

- When braking heavily, bear in mind that the ABS control cannot always be relied on to prevent the rear wheel from lifting off the ground.

What are the design characteristics of the BMW Motorrad ABS?

The BMW Motorrad ABS ensures riding stability on any surface within the limits of riding physics.

From a speed greater than 2.5 mph (4 km/h), the BMW Motorrad ABS can ensure riding stability on any surface within the limits of riding physics. At lower speeds, the BMW Motorrad ABS cannot provide optimal support on all surfaces due to system limitations.

The system is not optimized for the special conditions encountered under the extreme conditions of competitive off-road and racetrack use.

Special situations

To detect the tendency of the wheels to lock up, the speeds of the front and rear wheel are compared. If implausible values are detected over a longer period of time, the ABS function is switched off for safety reasons, and an ABS error is displayed. A self-diagnosis routine must be completed before the fault memory entry will be displayed.

Apart from problems with the BMW Motorrad ABS, unusual riding conditions can also cause a fault memory entry to be generated:

- Riding on the rear wheel (wheelie) for a longer period.
- Rear wheel spinning in place with front wheel brake engaged (burn out).
- Warm-up on the center or auxiliary stand at idle or with gear engaged.
- Rear wheel locked-up for a longer period of time by engine brake, e.g. when riding downhill on slippery surfaces.

Should a fault memory entry occur due to an unusual riding condition, the ABS function can be reactivated by switching the ignition off and then on again.

How important is regular maintenance?



WARNING

Brake system not regularly serviced

Accident hazard

- To ensure that the BMW Motorrad ABS is in a properly maintained condition, it is vital that the specified service intervals are kept to.

Reserves for safety

But remember, the potentially shorter braking distances that the BMW Motorrad ABS permits must not be used as an excuse for careless riding. ABS is primarily a means of ensuring a safety margin in genuine emergencies.

Be careful in curves! When you apply the brakes on a corner, the motorcycle's weight and momentum take over and even the BMW Motorrad ABS is unable to counteract their effects.

Further development of ABS to ABS Pro

In the past, the BMW Motorrad ABS system provided for a very high level of safety while braking during straight-ahead riding. Now ABS Pro also offers increased safety even when performing the braking process around curves. ABS Pro prevents the wheels from locking up, even in the event that the brakes are applied quickly. ABS Pro reduces abrupt changes in steering forces, especially during shock braking, and therefore decreases the risk of the occurrence of inadvertent lift-off of the vehicle.

ABS control

From a technical standpoint, ABS Pro adjusts the ABS control to the angle of inclination of the motorcycle based on the respective riding situation. Signals for the roll and yaw rate and the lateral acceleration are used to determine the inclination of the vehicle.

With an increasing inclination, the brake pressure gradient is increasingly limited at the start of braking. This results in a slower pressure buildup. In

addition, the pressure modulation in the range of the ABS control is more uniform.

Advantages for the rider

The advantages of ABS Pro for the rider are sensitive response and high braking and riding stability with the best possible deceleration, even around curves.

TRACTION CONTROL (DTC)

How does traction control work?

The traction control compares the wheel circumferential velocities of the front and rear wheels. The slip, and with it the stability reserves at the rear wheel, are determined from the speed difference. The engine control adapts the engine torque when the slip limit is exceeded.

BMW Motorrad DTC is designed as an assistance system for the rider and for riding on public roads. The extent to which the rider affects DTC control can be considerable (weight shifts when cornering, loose luggage on the motorcycle), especially when approaching the limits imposed by the laws of physics.

The **Enduro** riding mode should be activated for off-road riding. In this mode, the control intervention by the DTC is performed slightly later in this mode, enabling controlled drifting.

The system is not optimized for the special conditions encountered under the extreme conditions of competitive off-road and racetrack use. BMW Motorrad DTC can be switched off in such instances.



WARNING

Risky riding style

Risk of accident despite DTC

- The rider is always responsible for adapting his/her driving style.
- Do not reduce the system's extra safety margin with careless riding or unnecessary risks.

Special situations

As lean angles increase, acceleration capability is also progressively restricted by the laws of physics. This can result in reduced acceleration when coming out of very tight curves.

140 TECHNOLOGY IN DETAIL

To detect spinning or slipping away of the rear wheel, the speeds of the front and rear wheel are compared and the angle is considered, for example.

If the values for the lean angle are detected to be implausible for a long period, a replacement value is used for the angle, or the DTC function is switched off. In these cases, a DTC error is displayed. A self-diagnosis must be completed before the fault memory entry will be displayed.

Under the following unusual riding conditions, BMW Motorrad Traction Control may be deactivated automatically.

Unusual riding conditions:

- Riding on the rear wheel (wheelie) for a longer period.
- Rear wheel spinning in place with front wheel brake engaged (burn out).
- Warming up the engine on an auxiliary stand in neutral or with gear engaged.

Switching the ignition off and on again and then riding the motorcycle at a minimum speed reactivates the DTC.



Minimum speed for DTC activation

min 3 mph (min 5 km/h)

If the front wheel loses contact with the ground under extreme acceleration, the DTC reduces the engine torque in the RAIN and ROAD riding modes until the front wheel makes contact with the ground again.

The riding modes ENDURO and ENDURO PRO are designed for off-road riding and are not suitable for road operation.

In the riding modes DYNAMIC and ENDURO, the front wheel lift-off detection permits brief wheelies.

The front wheel lift-off detection is switched off in riding mode ENDURO PRO.

BMW Motorrad recommends that you respond to the front wheel lifting off by letting off on the throttle grip somewhat to return to a stable riding state as quickly as possible.

In the RAIN, ROAD, DYNAMIC, and ENDURO riding modes, the

DTC setting corresponds to the riding mode.

In the **ENDURO PRO** riding mode, DTC can be set differently.

ENGINE DRAG TORQUE CONTROL

–with riding modes Pro^{OE}

How does dynamic engine brake control work?

The purpose of the dynamic engine brake control is to safely prevent unstable riding conditions that are related to excess drag torque at the rear wheel. Depending on the road condition and riding dynamics, excess drag torque can make the slip at the rear wheel increase severely and impede riding stability. The dynamic engine brake control reduces slip at the rear wheel to a safe, setpoint slip that is dependent on the mode.

Causes of excess slip at the rear wheel:

- Riding in coasting overrun on a road with low coefficient of friction (e.g. wet leaves).
- Hopping when shifting gears down.
- Hard brake onset in sporty riding style.

Like the BMW Motorrad DTC traction control, the dynamic engine brake control compares the wheel centrifugal velocity of the front and rear wheel, which are calculated from the wheel RPM and the tire radius. The dynamic engine brake control can determine the slip, and therefore the stability reserve, on the rear wheel using the speed difference.

If the slip exceeds the respective limit value, the engine torque is increased by slightly opening the throttle valves. The slip is reduced, and the vehicle is stabilized.

Effect of the dynamic engine brake control

- In the **RAIN** and **ROAD** riding modes: maximum stability.
- with riding modes Pro^{OE}
- In the **DYNAMIC** riding mode: Reduced intervention when compared to the **RAIN** and **ROAD** riding modes.
- In the **ENDURO** and **ENDURO PRO** riding modes: Maximum Performance. Stability may be impaired on poorly surfaced roads or if using unsuitable tires.

142 TECHNOLOGY IN DETAIL

RIDING MODE

Selection

To adjust the motorcycle to the road condition and the desired riding experience, you can select from the following riding modes:

Series

- RAIN
- ROAD (standard mode)

-with riding modes Pro^{OE}

With Pro riding modes

- DYNAMIC
- ENDURO
- ENDURO PRO

For each of these riding modes, there is a coordinated setting for the ABS and DTC systems, engine drag torque control and the throttle response.

The DTC can be turned off in any riding mode. The following explanations always refer to the riding safety systems that are turned on.

Throttle response

- In the RAIN riding mode: soft throttle response.
- In the ROAD riding mode: optimal throttle response.

- with riding modes Pro^{OE}
- In the DYNAMIC riding mode: direct throttle response.
- In the ENDURO riding mode: soft throttle response.
- In the ENDURO PRO riding mode: optimal throttle response.
- In the ENDURO PRO riding mode, the throttle response can be set differently (▶▶▶ 91).

ABS

- The rear wheel lift-off detection is active in all riding modes except ENDURO PRO.
- In the DYNAMIC and ENDURO riding modes, rear wheel lift-off detection is reduced in order to achieve a greater braking effect.
- In the RAIN, ROAD and DYNAMIC riding modes, the ABS is set for road use.
- In ENDURO riding mode, ABS is set for off-road use with road tires.
- In riding mode ENDURO PRO, there is no ABS control on the rear wheel when the foot-brake lever is actuated. The ABS is adjusted to off-road use with cleated tires.

ABS Pro

- In the RAIN and ROAD riding modes, ABS Pro is available to its full capacity. The stand-up tendency the motorcycle has when braking in curves is reduced to a minimum.
- In the DYNAMIC and ENDURO riding modes, ABS Pro is available only when the traction conditions are good. The support is reduced compared to the ROAD riding mode and is instead designed to achieve the greatest braking effect.
- In the ENDURO PRO riding mode, the ABS Pro is not available.

DTC**Tires**

- In the RAIN, ROAD and DYNAMIC riding modes, the DTC is set for road use with road tires.
- In ENDURO riding mode, the DTC is set for off-road use with road tires.
- In ENDURO PRO riding mode, the DTC is set for off-road use with cleated tires.

Riding stability

- In the RAIN riding mode, the DTC intervenes early enough to ensure that maximum riding stability is achieved.
- In the ROAD riding mode, the DTC intervenes at a later point than in the RAIN riding mode. Rear wheel spinning without traction is avoided wherever possible.
- In the RAIN and ROAD riding modes, the front wheel is prevented from lifting off the road.
- In the DYNAMIC riding mode, the DTC intervenes later than in the ROAD riding mode so that minor drifts and brief wheelies are possible at the end of curves.
- In the ENDURO riding mode, the DTC intervenes even later and it is set to off-road use so that longer drifts and brief wheelies are possible at the end of curves.
- In the ENDURO PRO riding mode, the control of the DTC assumes that cleated tires are being used for off-road riding. Longer wheelies as well as wheelies at small angles are permitted. The front wheel lift-off detection is switched off, which means that it is

144 TECHNOLOGY IN DETAIL

possible to flip over backwards in extreme cases!

DYNAMIC BRAKE CONTROL

–with riding modes Pro^{OE}

Dynamic Brake Control function

The Dynamic Brake Control function helps the rider in the event of emergency braking.

Detection of emergency braking

–Emergency braking is detected when the front wheel brake is applied quickly and with force.

Behavior during emergency braking

–If emergency braking is applied at a speed of more than 10 km/h, in addition to the ABS function, the Dynamic Brake Control function will also be activated.

Behavior in the event of accidental activation of the throttle grip

–If the throttle grip is accidentally actuated during emergency braking (throttle position >5%), the intended braking effect is ensured by the Dynamic Brake Control ignoring the opening process of the throttle grip. This ensures

the effectiveness of emergency braking.

- If the gas is shut off (throttle position <5%) during the intervention of the Dynamic Brake Control, the engine torque required by the ABS brake system will be restored.
- If hazard braking is stopped and the throttle grip is still under actuation, the Dynamic Brake Control adjusts the engine torque back to the rider's choice.

TIRE PRESSURE MONITOR (RDC)

–with tire pressure monitor (TPM)^{OE}

Function

A sensor located in each tire monitors the air temperature and the pressure inside the tire and transmits this information to the control unit.

The sensors are equipped with a centrifugal controller, which does not enable the transmission of the measured values until the minimum speed is exceeded for the first time.



Minimum speed for the transmission of the RDC measured values:

min 19 mph (min 30 km/h)

Before initial reception of the tire pressure, -- is shown in the display for each tire. The sensors continue to transmit the measured readings for some time after the vehicle comes to a stop.

	Transmission time of the measured values after vehicle standstill:
min 15 min	

If an RDC control unit is installed but the wheels have no sensors, a fault memory entry is generated.

Tire inflation pressure ranges

The RDC control unit distinguishes between three inflation pressure ranges matched to the motorcycle:

- Tire pressure within the permissible tolerance.
- Tire pressure at the limits of the permissible tolerance.
- Tire pressure outside the permissible tolerance.

Temperature compensation

The tire pressure is temperature dependent, i.e. it increases or decreases together with the tire air temperature. The tire temperature is dependent on the outside temperature, the

riding style and the length of the journey.

	The tire pressures are shown in the display with temperature compensation and are always based on the following tire air temperature:
68 °F (20 °C)	

Tire pressure gauges at filling stations do not compensate for temperature; the tire pressure that is measured depends on the tire air temperature. As a result, in most cases the values displayed there do not match the values shown in the display.

Tire pressure adjustment

Compare the RDC value in the display with the value on the back cover of the rider's manual. The difference between the two values must be compensated with the tire pressure gauge at the filling station.

	Example
According to the operating instructions, the tire pressure should have the following value:	
36.3 psi (2.5 bar)	

 Example
The following value is indicated in the display:
33.4 psi (2.3 bar)
The shortfall is thus:
2.9 psi (0.2 bar)
The tester at the filling station shows:
34.8 psi (2.4 bar)
To produce the correct tire pressure, this must be increased to the following value:
37.7 psi (2.6 bar)

GEAR SHIFT ASSISTANT

—with Gearshift Assistant Pro^{OE}

Gear Shift Assistant Pro

Your motorcycle is equipped with the Gear Shift Assistant Pro originally developed for racing but now specially adapted for touring use. It allows you upshift and downshift under almost any load conditions and in virtually all engine-speed ranges without operating the clutch or accelerator.

Benefits

- 70-80 % of all gear shifts can be performed without using the clutch.
- Less movement between rider and passenger due to shorter gear-change intervals.
- Throttle valve does not have to be closed when changing gear under acceleration.
- During deceleration and downshifts (throttle plate closed) the system blips the throttle valve to obtain the correct engine speed.
- Shifting times are faster than when the clutch is used to shift gears.

For the system to detect the rider's intention to change gears, the gearshift lever previously not operated must be moved against the spring force by a certain amount of "overtravel" in the desired direction with a normal to brisk action and held in that position until the gear change is completed. A further increase of the force applied to the gearshift lever during the gear-shift operation is not necessary. After the gear change is completed, the gearshift lever must be fully released before the Gear Shift

Assistant Pro can execute a new gear change. The load condition (throttle position) should remain constant both prior to and during execution of gear shifts using the Gear Shift Assistant Pro. Changing the throttle position during the gear-shift operation may cause the function to abort and/or the gear change to fail. The Gear Shift Assistant Pro does not provide support when gear shifts are made with clutch control.



Idle speed

$1250 \pm 50 \text{ min}^{-1}$ (Engine at operating temperature)

Downshifts

–Downshifts are assisted up to the speed at which the engine reaches maximum rpm in the gear to be engaged. Over-revving is thus prevented.



Maximum engine speed

max 9250 min^{-1}

Upshifts

–Upshifting is supported until the idling speed is reached in the required gear.
 –The engine speed is thus prevented from dropping below idle speed.

MAINTENANCE

09

GENERAL NOTES	150
ONBOARD VEHICLE TOOL KIT	151
FRONT WHEEL STAND	151
REAR-WHEEL STAND	152
ENGINE OIL	152
BRAKE SYSTEM	154
CLUTCH	159
COOLANT	160
TIRES	162
RIMS	163
WHEELS	163
DRIVE CHAIN	175
AIR FILTER	179
LIGHT SOURCES	181
TRIM PANEL COMPONENTS	181
JUMP-STARTING	182
BATTERY	183
FUSES	188
DIAGNOSTIC CONNECTOR	189

150 MAINTENANCE

GENERAL NOTES

The "maintenance" chapter describes work involving the checking and replacement of wearing parts that can be performed with a minimum of effort.

If specific tightening torques are to be taken into account for installation, these are listed. An overview of all required tightening torques is contained in the "Technical data" chapter.

Special tools and thorough specialized knowledge are required to carry out some of the work described here. If in doubt, contact a repair shop, preferably an authorized BMW Motorrad dealer.

Microencapsulated screws

The microencapsulation is a chemical threadlocker. An adhesive is used to create a solid connection between screw and nut or component. Microencapsulated screws, therefore, are suitable for single use only. Regardless of the removal or installation, the hole must always be cleaned. After removal, the internal thread must be cleaned to remove adhesive. During installation, a new mi-

croencapsulated screw must be used. Before removal, make sure that you have suitable tools for cleaning the thread and a replacement screw. If you carry out the work improperly, the locking function of the screw might no longer be guaranteed, which puts you in danger!

Disposable cable ties

Occasionally cables and wires are secured with disposable cable ties. To prevent cables and wires from getting damaged during removal, a suitable tool must be used, e.g. diagonal cutting pliers.

For reinstallation, cables and wires that were cut free must be secured with new disposable cable ties.

Protrusions should be cut off with cable tie pliers.

ONBOARD VEHICLE TOOL KIT

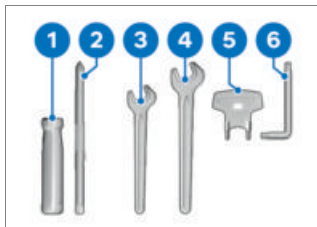

- 1 Screwdriver handle
- 2 Reversible screwdriver insert with Phillips and slotted blade
 –Remove battery. (▶▶▶ 185)
 –Adjust damping at the rear wheel. (▶▶▶ 108)
- 3 Open-ended wrench
 Key range: 14 mm
 –Adjust the mirror arm. (▶▶▶ 102)
- 4 Open-ended wrench
 Key range: 19
 –without lowered^{OE}
 –Adjust the spring preload on the front wheel. (▶▶▶ 105)
- 5 Keys
 –Adjust the spring preload at the rear wheel. (▶▶▶ 105)
- 6 Torx wrench, T25/T30
 T25 on short end, T30 on long end
 –Remove the tank cover. (▶▶▶ 181)

FRONT WHEEL STAND

Attaching the front wheel stand



ATTENTION

Use of the BMW Motorrad front wheel stand without an auxiliary stand

Component damage cause by tipping over

- Place the motorcycle on an auxiliary stand before lifting the front wheel with the BMW Motorrad front-wheel stand.
- Ensure that the motorcycle is standing securely.
- Place motorcycle on an auxiliary stand; BMW Motorrad recommends the BMW Motorrad auxiliary stand.
- Attach the rear-wheel stand. (▶▶▶ 152)

152 MAINTENANCE



- For a description of the correct installation, please refer to the instructions for the front wheel stand.
- BMW Motorrad offers a suitable auxiliary stand for each vehicle. Your authorized BMW Motorrad dealer will be very happy to assist you in choosing the suitable auxiliary stand.

REAR-WHEEL STAND

Attaching the rear-wheel stand



- For a description of the correct installation, please re-

fer to the instructions for the rear-wheel stand.

- BMW Motorrad offers a suitable auxiliary stand for each vehicle. Your authorized BMW Motorrad dealer will be very happy to assist you in choosing the suitable auxiliary stand.

ENGINE OIL

Checking the engine oil level



ATTENTION

Misinterpretation of the oil capacity because the oil level is temperature-dependent (the higher the temperature, the higher the oil level)

Engine damage from incorrect filling

- Only check the oil level after an extended ride or when the engine is warm.
- Clean the area around the oil filler opening.
- Allow the engine to idle in Neutral until the fan starts up, then allow it to idle one minute longer.
- Turn off engine.

**ATTENTION****Lateral tipping of the vehicle**

Component damage caused by tipping over

- Secure the vehicle from tipping over laterally, preferably with the support of a second person.
- When the engine is at operating temperature, position the motorcycle vertically on ground that is level and firm. BMW Motorrad recommends the use of a suitable auxiliary stand.
 - with center stand^{OA}
- Make sure the surface is level and firm and place the motorcycle on its center stand at operating temperature.<

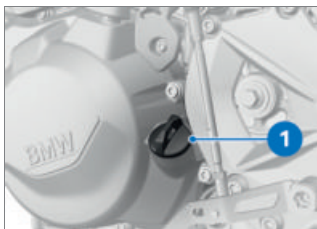

- Wait one minute to allow the oil to drain into the oil pan.
- Remove oil dipstick **1**.



- Clean measuring area **2** using a dry cloth
- Place oil dipstick on oil filler opening, but do not install. For better readability, turn back by one turn.
- Remove the oil level dipstick and check oil level.

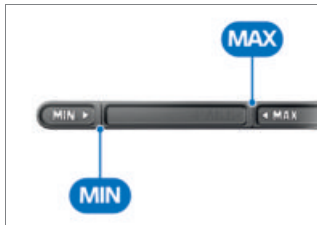

 Specified level of engine oil

Between **MIN** and **MAX** mark

 Engine oil, quantity for topping up

max 0.5 quarts (max 0.5 l)
(Difference between **MIN** and **MAX**)

154 MAINTENANCE

If the oil level is below the **MIN** mark:

- Top up engine oil. (▣▣▣▣ 154)

If the oil level is above the **MAX** mark:

- Have the oil level corrected at a repair shop, preferably an authorized BMW Motorrad dealer.
- Install oil level dipstick.

 To prevent unnecessary pollution of the environment, BMW Motorrad recommends checking the engine oil after riding min 31 miles (min 50 km).

Topping up the engine oil

- Park the motorcycle, making sure the ground is level and firm.
- Wipe the area around the oil filler opening clean.

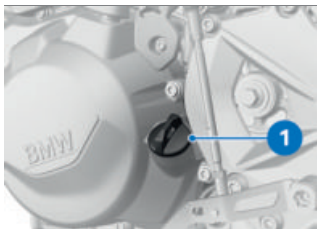

- Remove oil dipstick **1**.



ATTENTION

Use of too little or too much engine oil

Engine damage from incorrect filling

- Always make sure that the oil level is correct.
- Top up the engine oil to the specified level.
- Check engine oil level. (▣▣▣▣ 152)
- Install oil level dipstick.

BRAKE SYSTEM

Checking brake function

- Actuate brake lever.
 - » The resistance point must be clearly perceptible.
 - Press the footbrake lever.
 - » The resistance point must be clearly perceptible.
- If resistance points are not clearly perceptible:



ATTENTION

Improper working on the brake system

Endangering of the operating safety of the brake system

- Have all work on the brake system carried out by experts.

- Have the brakes checked by a repair shop, preferably an authorized BMW Motorrad dealer.

Checking the front brake pad thickness

- Park the motorcycle, making sure the ground is level and firm.



- Visually inspect the left and right brake pads to ascertain their thickness. Direction of view: between wheel and front suspension to brake calipers **1**.



 Front brake-pad wear limit

min 0.04 in (min 1.0 mm)
(Only friction material without carrier plate. The wear markings, i.e. the grooves, must be clearly visible.)

If the wear marks are no longer clearly visible:

WARNING

Dropping below the minimum pad thickness

Reduced braking action, damage to the brake

- In order to ensure the operating reliability of the brake system, make sure that the brake pads are not worn beyond their minimum thickness.

- Have brake pads renewed at a repair shop, preferably an authorized BMW Motorrad dealer.

156 MAINTENANCE

Checking the rear brake pad thickness

- Park the motorcycle, making sure the ground is level and firm.



- Conduct a visual inspection of the brake pad thickness. Direction of view: from rear toward brake caliper **1**.



Rear brake-pad wear
limit

min 0.04 in (min 1.0 mm)
(Only friction material without
carrier plate.)

If brake pads are worn:



WARNING

Dropping below the minimum pad thickness

Reduced braking action, damage to the brake

- In order to ensure the operating reliability of the brake system, make sure that the brake pads are not worn beyond their minimum thickness.

- Have brake pads renewed at a repair shop, preferably an authorized BMW Motorrad dealer.

Checking the front brake fluid level



WARNING

Insufficient or contaminated brake fluid in the brake fluid reservoir

Considerably reduced braking power caused by air, dirt or water in the brake system

- Stop riding immediately until fault is rectified.
- Check brake fluid level regularly.
- Make sure that the lid of the brake fluid reservoir is cleaned before opening.
- Make sure that brake fluid is used from a sealed container only.

–with center stand^{OA}

- Make sure the ground is level and firm and put the motorcycle on its center stand.
- Move the handlebars to the straight-ahead position. ◁
- Position the motorcycle vertically, making sure that the ground is firm and level.
- Move the handlebars to the straight-ahead position.



- Check brake fluid level at brake fluid reservoir for front wheel brake **1**.



The brake fluid level in the brake fluid reservoir drops due to brake pad wear.



Front brake fluid level

Brake fluid, DOT4

The brake fluid level must not fall below the **MIN** mark. (Brake fluid reservoir horizontal, vehicle standing upright)

158 MAINTENANCE

If the brake fluid level falls below the approved level:

- Have the fault rectified as soon as possible by a repair shop, preferably an authorized BMW Motorrad dealer.

Checking the rear brake fluid level



WARNING

Insufficient or contaminated brake fluid in the brake fluid reservoir

Considerably reduced braking power caused by air, dirt or water in the brake system

- Stop riding immediately until fault is rectified.
 - Check brake fluid level regularly.
 - Make sure that the lid of the brake fluid reservoir is cleaned before opening.
 - Make sure that brake fluid is used from a sealed container only.
- Position the motorcycle vertically, making sure that the ground is firm and level.
–with center stand^{OA}
- Make sure the ground is level and firm and put the motorcycle on its center stand.◁



- Check the brake fluid level at the brake fluid reservoir for rear wheel brake **1**.



The brake fluid level in the brake fluid reservoir drops due to brake pad wear.

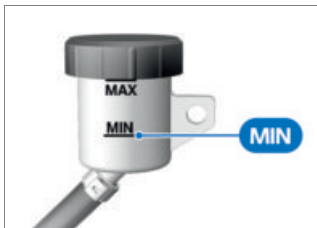

Rear brake fluid level
(visual inspection)

Brake fluid, DOT4

The brake fluid level must not fall below the **MIN** mark.

If the brake fluid level falls below the approved level:

- Have the fault rectified as soon as possible by a repair shop, preferably an authorized BMW Motorrad dealer.

CLUTCH

Checking the clutch function

- Pull the clutch lever.
- » A rising force must be perceptible upon increasing operation.

If no rising force can be felt upon increasing operation:

- Have the clutch checked by a repair shop, preferably an authorized BMW Motorrad dealer.

Checking clutch pedal free play

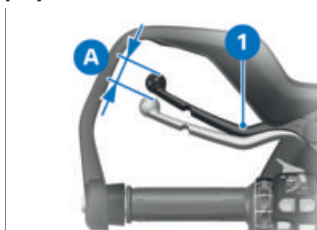

- Actuate clutch lever **1** several times until it touches the handle.
- Actuate clutch lever **1** slightly until you can feel resistance while observing the free play of the clutch pedal **A**.



Clutch cable play

0.12...0.2 in (3...5 mm) (along the outside of the hand lever, handlebars in the straight-ahead position, when the engine is cold)

If the clutch pedal free play is outside of tolerance:

- Adjust clutch pedal free play. (→ 159)

Adjusting clutch pedal free play

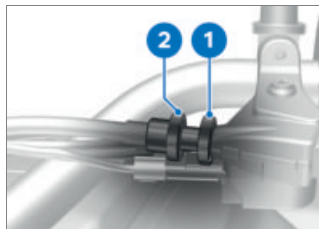

- Loosen lock nut **1**.
- To increase clutch pedal free play: Turn the adjustment screw **2** into the handlebar fitting.
- To reduce clutch pedal free play: Turn the adjustment screw **2** out of the handlebar fitting.



The distance between lock nuts and nuts (measured inside) must not exceed 0.31 ± 0.06 in (8 ± 1.5 mm).

160 MAINTENANCE

If the correct clutch pedal free play can only be set through further unscrewing, contact a repair shop, preferably an authorized BMW Motorrad dealer.

- Check clutch pedal free play. (→ 159)
- Tighten lock nut **1**, hold down adjustment screw **2** while doing so.

COOLANT

Checking the coolant level

- Park the motorcycle upright, making sure that the ground is firm and level.
- Turn the handlebars to the right.



- Check coolant level at expansion tank **1**. Line of sight: from the rear, through the opening and into the right side trim panel.



Required coolant level

Between **MIN** and **MAX** marks on the expansion tank (Engine cold)

If the coolant level drops below the permitted level:

- Top up coolant.

Topping up coolant



WARNING

Opening the radiator cap

Risk of burning

- Do not open the radiator cap when it is hot.
- Check the coolant level exclusively at the expansion tank and top up if necessary.

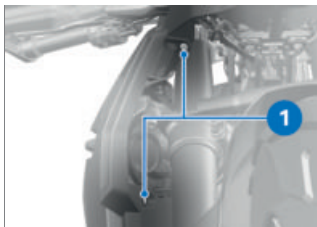

- Unscrew the screws of the radiator cowl **1**.



- Open cap **1** of expansion tank.
- Top up the coolant until it reaches the target level using a suitable funnel.
- Check the coolant level. (→ 160)
- Close cap **1** of expansion tank.



- Unscrew the screws of the radiator cowl **2**.



- Insert the radiator cowl **1** into the holders **2**.
- » The radiator cowl will audibly engage.



- Pull the radiator cowl **1** out of the holders **2**.

162 MAINTENANCE



- Tighten the screws of the radiator cowl **2**.



- Tighten the screws of the radiator cowl **1**.

TIRES

Checking tire pressure

WARNING

Incorrect tire pressure

Worse handling characteristics of the motorcycle, reduction in the service life of the tires

- Ensure correct tire pressure.

WARNING

Automatic opening of vertically installed valve inserts at high speeds

Sudden loss of tire inflation pressure

- Use valve caps with rubber sealing ring and screw on firmly.

- Park the motorcycle, making sure the ground is level and firm.
- Check tire pressure against data below.



Front tire pressure

31.9 psi (2.2 bar) (One-up mode, with cold tires)

36.3 psi (2.5 bar) (Two-up and/or load, with cold tire)



Rear tire pressure

36.3 psi (2.5 bar) (One-up mode, with cold tires)

42.1 psi (2.9 bar) (Two-up and/or load, with cold tire)

If tire pressure is too low:

- Correct the tire pressure.

Checking tire tread depth



WARNING

Riding with heavily worn tires

Risk of accident due to poorer rideability

- If necessary, replace the tires before the legally specified minimum tread depth is reached.

- Park the motorcycle, making sure the ground is level and firm.
- Measure tire tread depth in main tread grooves with wear marks.



Wear marks are integrated into the main grooves on every tire. If the tire tread has worn down to the level of the marks, the tire is completely worn. The locations of the marks are indicated on the edge of the tire, e.g. by the letters TI, TWI or by an arrow.

When the minimum tread depth is reached:

- Replace the worn tire.

RIMS

Checking rims

- Park the motorcycle, making sure the ground is level and firm.
- Visually inspect rims for defects.
- Have damaged rims checked and, if necessary, renewed by a repair shop, preferably an authorized BMW Motorrad dealer.

Checking spokes

- Park the motorcycle, making sure the ground is level and firm.
- Run the handle of a screwdriver or similar object over the spokes and listen to the sound pattern.

If the sound pattern is uneven:

- Have spokes checked by a repair shop, preferably by an authorized BMW Motorrad dealer.

WHEELS

Tire recommendation

For every tire size, BMW Motorrad has tested and approved certain tire brands as roadworthy. BMW Motorrad cannot evaluate the suitability of any other tires, and therefore cannot take

164 MAINTENANCE

responsibility for their riding safety.

BMW Motorrad recommends only using the tires tested and approved by BMW Motorrad. Your authorized BMW Motorrad dealer can provide you with more detailed information.

Effect of wheel sizes on suspension control systems

The wheel sizes play an important role with suspension control systems. The diameter and width of the wheels stored in the control unit have particular significance as the basis for all necessary calculations. A change in these sizes resulting from conversion to wheels not installed as standard equipment can seriously affect the control convenience of these systems. The sensor rings required for wheel speed detection must also match the installed control systems and may not be replaced.

If you want to convert your motorcycle to different wheels, please contact a repair shop, preferably an authorized BMW Motorrad dealer. In some cases, the data stored in the

control units can be adapted for the new wheel sizes.

Removing the front wheel

- Park the motorcycle, making sure the ground is level and firm.

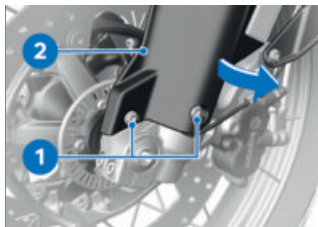

- Remove screws **1**.
- Carefully swing the lower part of the front wheel cover **2** in the arrow direction.

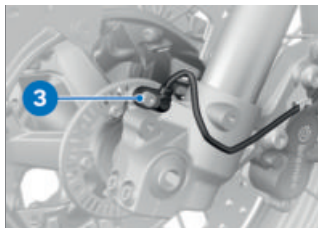

- Remove the screw **3** and remove the wheel speed sensor from the drilled hole.

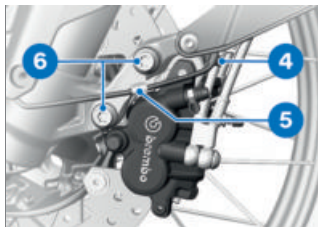

- Detach the wheel speed sensor cable from the holding clip **4** and holder **5**.
- Remove the mounting bolts **6** and holder **5** of the left brake caliper.
- Remove the mounting bolts **6** of the right brake caliper.

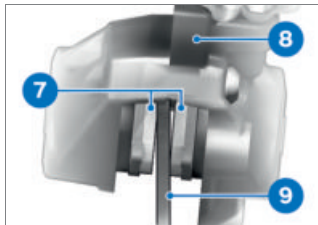

- Push the brake pads **7** apart slightly by turning the brake caliper **8** against the brake disc **9**.

ATTENTION

Using hard or sharp-edged objects near the component

Component damage

- Do not scratch components, if necessary tape off or cover.

- Mask off areas of the wheel rim that could get scratched in the process of removing the brake calipers.

ATTENTION

Unintentional pressing together of brake pads

Component damage when mounting the brake caliper or when pressing the brake pads apart

- Do not actuate the brakes with the brake caliper removed.

- Carefully pull the brake calipers back and outward to remove them from the brake disks.
- Place motorcycle on a suitable auxiliary stand.
- Attach the rear-wheel stand.
( 152)

166 MAINTENANCE

—with center stand^{OA}

- Make sure the ground is level and firm and put the motorcycle on its center stand.◁
- Raise front of motorcycle until the front wheel can turn freely. BMW Motorrad recommends using the BMW Motorrad front wheel stand for propping up the motorcycle.
- Attach the front wheel stand. (▮▮▮ 151)

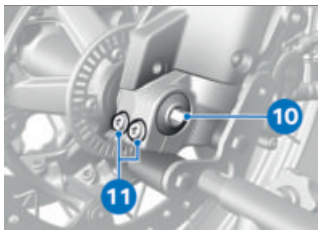

- Remove axle bolt **10**.
- Unscrew axle clamping bolts **11** on left side.

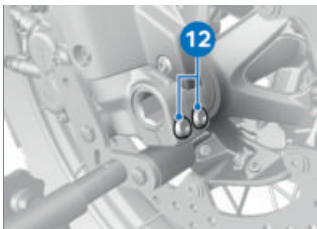

- Unscrew axle clamping bolts **12** on right side.

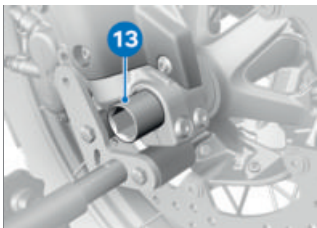

- Remove axle **13** while supporting the wheel.
- Do not remove grease on axle.
- Roll the front wheel forward to remove it.



- Remove spacer bushing **14** on left side from wheel hub.

Installing the front wheel

WARNING

Use of a wheel which does not comply with series specifications

Malfunctions during control interventions by ABS and DTC

- Please see the information on the effect of wheel sizes on the ABS and DTC chassis control systems at the beginning of this chapter.

ATTENTION

Tightening screw connections with incorrect tightening torque

Damage to or loosening of screw connections

- Have the tightening torques checked by a repair shop, preferably by an authorized BMW Motorrad dealer.



- Lubricate the contact surface on the spacer bush **14**.



Lubricant

Unirex N3

- Insert the spacer bushing **14** into the wheel hub on the left side with the collar facing outwards.

168 MAINTENANCE

ATTENTION

Front wheel installation opposite the running direction

Accident hazard

- Observe running direction arrows on tire or rim.
- Roll the front wheel into the front suspension.

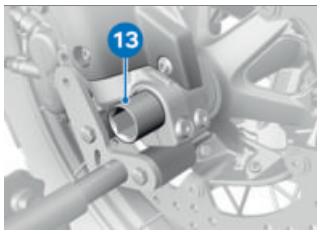

- Lubricate quick-release axle **13**.



Lubricant

Unirex N3

WARNING

Improper installation of quick-release axle

Loosening of the front wheel

- After the brake caliper is fastened and the spring fork is relaxed, tighten the quick-release axle and axle clamping with the specified torque.
- Raise the front wheel and insert the quick-release axle **13** as far as possible.

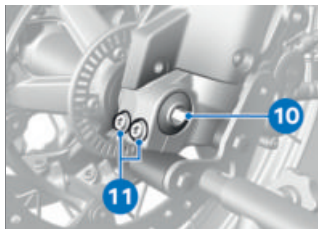

- Install the axis screw **10** with torque. Brace quick-release axle on the right side at the same time.



Axle screw in front quick-release axle

M20 x 1.5

37 lb/ft (50 Nm)

- Remove front wheel stand and firmly compress front

forks. Do not actuate brake lever at the same time.

- Attach the front wheel stand. (→ 151)
- Tighten left-hand axle clamping screws **11** to appropriate torque.

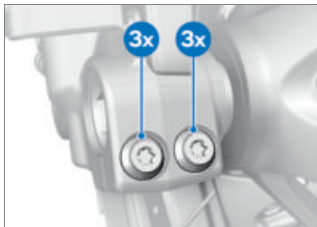

Pinch bolt on quick-release axle

Tightening sequence: Tighten the screws 6 times, alternating between one and the other each time

M8 x 35

14 lb/ft (19 Nm)

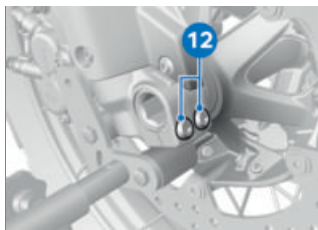

- Tighten right axle clamping screws **12** to specified tightening torque.

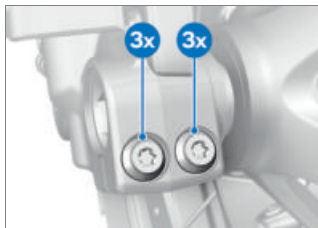

Pinch bolt on quick-release axle

Tightening sequence: Tighten the screws 6 times, alternating between one and the other each time

M8 x 35

14 lb/ft (19 Nm)

- Put the brake calipers on the left and right onto the brake disks.

170 MAINTENANCE

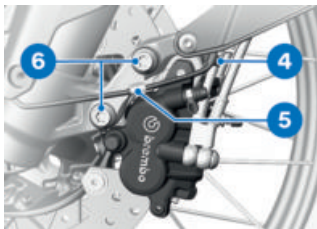

- Install the mounting bolts **6** with the holder **5** of the link brake caliper and tighten them to the specified torque.



Brake caliper on telescopic forks

M10 x 45

28 lb/ft (38 Nm)

- Tighten the mounting bolts **6** of the right brake caliper to the specified torque.



Brake caliper on telescopic forks

M10 x 45

28 lb/ft (38 Nm)

- Remove adhesive tape from wheel rim.



WARNING

Brake pads do not contact the brake disc

Risk of accident due to delayed braking effect.

- Before driving off, check that the braking effect kicks in without any delay.
 - Engage the brake repeatedly, continuing until the brake pads are against the rotors.
 - Insert the wheel speed sensor cable into the holding clips **4** and **5**.
- 
- A close-up photograph showing the wheel speed sensor cable being inserted into a hole in the fork. A blue callout box with the number '3' points to the hole. The sensor cable is black and has a metal contact tip.
- Clean the thread for screw **3**.
 - Insert the wheel speed sensor into the bore and tighten the **new** screw **3** to the specified torque.



Wheel speed sensor at front on fork

M6 x 16

Thread-locking compound:
micro-encapsulated

 Wheel speed sensor at front on fork

6 lb/ft (8 Nm)

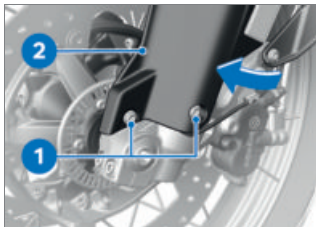

- Clean the thread for screws **1**.
- Move the lower part of the front wheel cover **2** into position.
- Install **new** screws **1**.

 Front wheel cover on telescopic forks

M6 x 16

Thread-locking compound: micro-encapsulated

2 lb/ft (3 Nm)

- Remove the front wheel stand.
- without center stand^{OA}
- Remove the auxiliary stand.
 - Place motorcycle on its side stand.<

Removing the rear wheel

ATTENTION

Unintentional pressing together of brake pads

Component damage when mounting the brake caliper or when pressing the brake pads apart

- Do not actuate the brakes with the brake caliper removed.
- Make sure the ground is level and firm and prop the motorcycle up on a suitable auxiliary stand.
- Attach the rear-wheel stand. (→ 152)
—with center stand^{OA}
- Make sure the ground is level and firm and put the motorcycle on its center stand.<
- Support the rear wheel, e.g. with a wooden block, so that it cannot fall down after the quick-release axle is removed.

172 MAINTENANCE

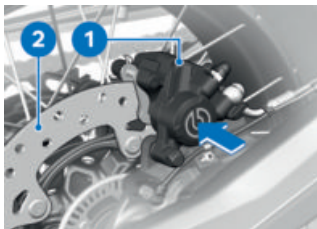

- Press the brake caliper **1** against the brake disk **2**.
» Brake pistons are pressed back.

- Loosen the adjustment screws **7** on both sides.
- Remove chain tensioner **6** and push axle in as far as possible.

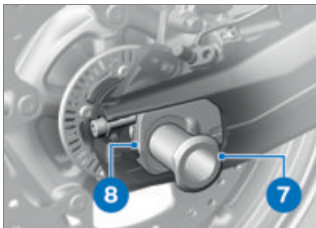

- Remove the quick-release axle **7** and the chain tensioner **8**.

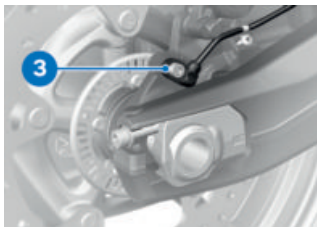

- Remove the screw **3** and remove the wheel speed sensor from the drilled hole.



- Roll the rear wheel as far forward as possible and remove the drive chain **9** from the camshaft sprocket.

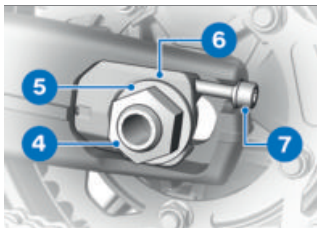

- Remove the axle nut **4** and washer **5**.

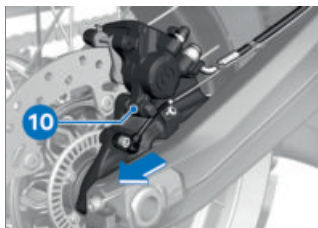

- Roll rear wheel toward rear out of swing arm while pulling brake caliper carrier **10** toward rear until rear-wheel rim can be guided past it.

 The camshaft sprocket and the spacer bushings on the left and right are loosely inserted in the wheel. During removal, make sure that the parts are not damaged or lost.

Installing the rear wheel

WARNING

Use of a wheel which does not comply with series specifications

Malfunctions during control interventions by ABS and DTC

- Please see the information on the effect of wheel sizes on the ABS and DTC chassis control systems at the beginning of this chapter.

ATTENTION

Tightening screw connections with incorrect tightening torque

Damage to or loosening of screw connections

- Have the tightening torques checked by a repair shop, preferably by an authorized BMW Motorrad dealer.

 The camshaft sprocket and the spacer bushings on the left and right are loosely inserted in the wheel. During installation, make sure that the parts are not damaged or lost.

- Roll the rear wheel on the support into the swinging arm until the brake-caliper support can be installed.

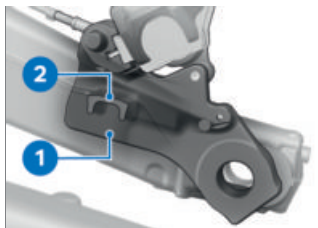

- Mount brake caliper mounting bracket **1** in guide **2**.

174 MAINTENANCE

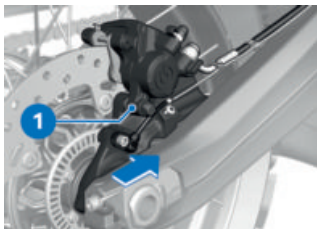

- Roll rear wheel further into swinging arm while simultaneously pushing brake caliper carrier **1** toward front.



- Roll the rear wheel as far forward as possible and place the drive chain **7** on the camshaft sprocket.

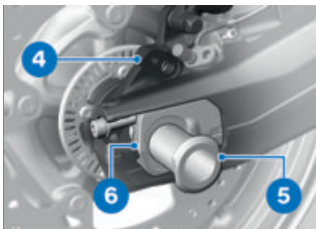

- Insert the right chain tensioner **6** into the rear wheel swinging arm.
- Lubricate the quick-release axle **5** and install it in the brake caliper mounting bracket **4** and rear wheel.



Lubricant

Unirex N3

- Make sure that the axle fits into the recess of the chain tensioner.

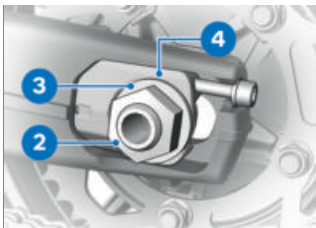

- Insert chain tensioner, left **4**.
- Install washer **3** and axle nut **2**, but do not tighten yet.

–without center stand^{OA}

- Remove the auxiliary stand.◁

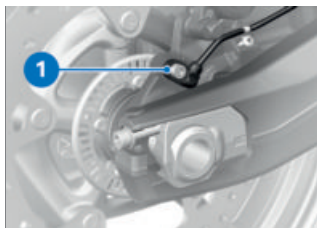

- Clean the thread for screw **1**.
- Insert the wheel speed sensor into the bore and tighten the **new screw 1** to the specified torque.



Rear wheel speed sensor on the brake caliper carrier

M6 x 16

Thread-locking compound:
micro-encapsulated

6 lb/ft (8 Nm)



WARNING

Brake pads do not contact the brake disc

Risk of accident due to delayed braking effect.

- Before driving off, check that the braking effect kicks in without any delay.

- After this work is complete, engage the brake repeatedly,

continuing until the brake pads seat against the discs.

- Adjust chain tension. (▶▶▶ 177)
- Check chain tension. (▶▶▶ 176)

DRIVE CHAIN

Lubricating the drive chain



ATTENTION

Insufficient cleaning and lubrication of the drive chain

Increased wear

- Clean and lubricate the drive chain regularly.
- Lubricate the drive chain every third fuel stop.
- Perform lubrication at shorter intervals after riding in wet conditions, or after riding in dusty or dirty conditions.
- Switch off ignition and engage Neutral.
- Clean drive chain with suitable cleaning agent, dry and apply chain lubricant.
- To extend and maximize the chain's service life, BMW Motorrad recommends using BMW Motorrad chain lubricant or:



Lubricant

Chain spray, O-ring compatible

176 MAINTENANCE

- Wipe off excess lubricant.

Caring for and lubricating the low-maintenance drive chain

—with M Endurance chain^{OE}



ATTENTION

Insufficient cleaning and lubrication of the drive chain

Increased wear

- Clean and lubricate the drive chain regularly.



The low-maintenance drive chain is cleaned and lubricated in the course of the annual service interval. In the interest of an optimum service life, the low-maintenance chain can be additionally relubricated using a chain lubricant suitable for low-maintenance chains.

Perform lubrication at shorter intervals if there is an above-average load from riding in salty, dusty or dirty conditions.

- Switch off ignition and engage Neutral.
- Clean drive chain with suitable cleaning agent, dry and apply chain lubricant. To extend and maximize the chain's service life BMW Motorrad recommends using BMW Motorrad chain lubricant or:



Lubricant

Chain spray, O-ring compatible

- Wipe off excess lubricant.

Checking chain tension

- Park the motorcycle, making sure the ground is level and firm.
- Turn the rear wheel until the position with the lowest chain sag is reached.

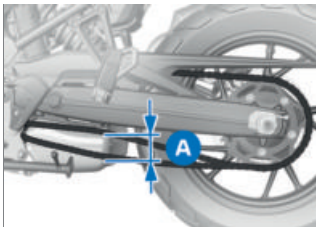

- Using a screwdriver, push the drive chain up and down in the middle between the pinion and camshaft sprocket and measure the difference **A**.



Chain sag

1.6...2 in (40...50 mm) (Motorcycle unloaded on side stand)

—with lowered^{OE}



Chain sag

1.4...1.8 in (35...45 mm) (Motorcycle unloaded on side stand)◁

If the measured value is outside the approved tolerance:

- Adjust chain tension. (▶▶▶ 177)

Adjusting chain tension

- Park the motorcycle, making sure the ground is level and firm.

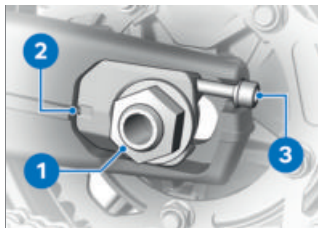

- Loosen axle nut **1**.
- Adjust chain tension with adjustment screws **3** on the left and right.
- Check chain tension. (▶▶▶ 176)
- Ensure that the identical scale value **2** is set on both the left and right.
- Tighten quick-release axle nut **1** to the specified torque.



Rear-wheel quick-release axle in swinging arm

M24 x 1.5

92 lb/ft (125 Nm)

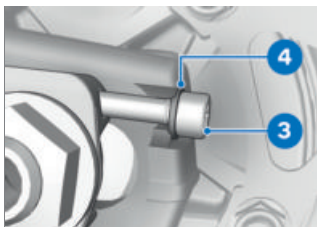

- Check whether the washer **4** is in full contact with the screw head **3** and correct if necessary.

Checking drive chain for wear Requirement

The chain tension is correctly adjusted.

- Park the motorcycle, making sure the ground is level and firm.

178 MAINTENANCE

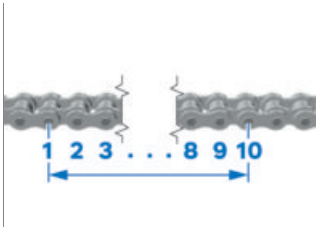

- Check whether the third marker line **1** is fully visible. If the third marker line **1** is fully visible, check the chain length:
- Engage 1st gear.
- Rotate the rear wheel in the riding direction until the drive chain is tensioned.
- Determine the chain length below the rear wheel swinging arm across the center of 10 rivets.
- Turn the rear wheel in the direction of travel and calculate the chain length at 3 different spots.



Permissible chain length

max 5.7 in (max 144 mm)
(Measured over the **center** of 10 rivets, drive chain under tension)

If the drive chain has reached the maximum approved length:

- Contact a repair shop, preferably an authorized BMW Motorrad dealer.

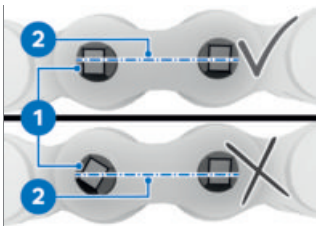

- Check to see whether a rivet head **1** has rotated.

Rivet heads should be parallel to the centerline of the drive chain **2**.

- Riveting is OK.

If one or more rivet heads has rotated:

- Contact a repair shop, preferably an authorized BMW Motorrad dealer.

AIR FILTER

Removing the air filter

- Remove the tank cover. (→ 181)

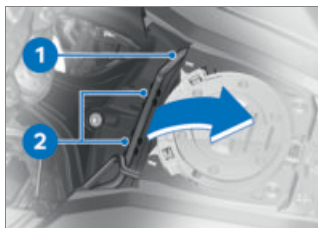

- Unclip the hose **1** from the retaining lugs **2**.

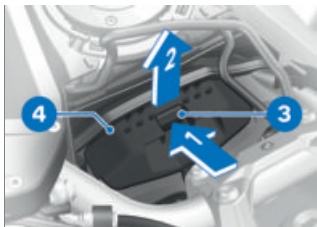

- To unlock, press and hold button **3** (arrow **1**).
- Pull the frame **4** out of the bracket (arrow **2**).



- Remove frame **4**.
- Remove air filter insert **5**.

Installing the air filter



ATTENTION

Insufficient filter function, intake of dirt particles. The air filter insert slips when being pushed in.

Component damage

- Insert the air filter insert correctly into the filter frame and hook into the pins.

180 MAINTENANCE

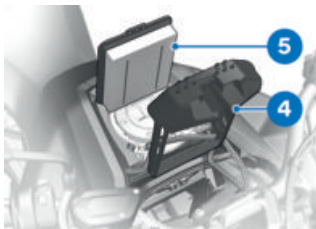

- Install the air filter **5** in the frame **4**.

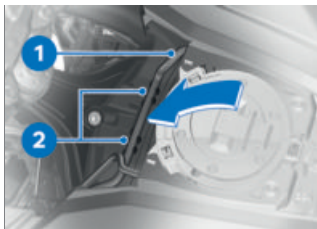

- Clip hose **1** into retaining lugs **2**.

–with Keyless Ride^{OE}



- Make sure that the air filter **5** is attached to the lugs **6** on the frame **4** correctly.

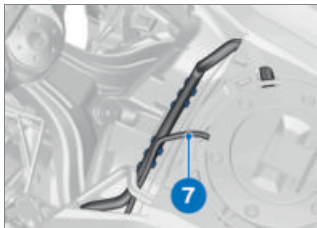

- Be sure that the cable **7** is not jammed.<

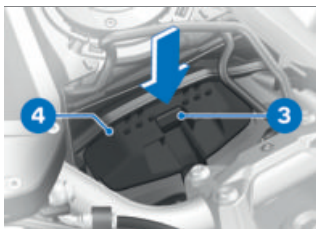

- Install frame **4**.
» Button **3** engages.

LIGHT SOURCES

Replacing the LED light source



WARNING

Overlooking the vehicle in road traffic due to failure of the lighting on the vehicle

Safety risk

- Replace defective lighting as soon as possible. Please contact a repair shop for this purpose, preferably an authorized BMW Motorrad dealer.

All light sources on the vehicle are LED light sources. The service life of the LED light sources is longer than the assumed service life of the vehicle. If an LED light source is faulty, please contact a repair shop, preferably an authorized BMW Motorrad dealer.

TRIM PANEL COMPONENTS

Removing the tank cover



- Remove screws **1**.

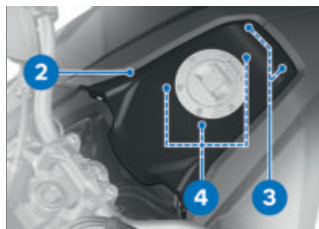

- Loosen and remove the tank cover **2** from the mounting clips **3** and retaining lugs **4**.

Installing the tank cover

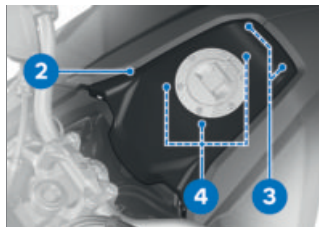

- Position the tank cover **2**.

182 MAINTENANCE

- Install the tank cover **2** with the detents **3** and **4**.



- Install screws **1**.

JUMP-STARTING

CAUTION

Touching live parts of the ignition system when the engine is running

Electrocution

- Do not touch parts of the ignition system when the engine is running.

ATTENTION

Current too high when jump-starting the motorcycle

Cable fire or damage to the motorcycle electronics

- Do not jump-start the motorcycle using the power socket, only via the battery terminal.

ATTENTION

Contact between crocodile clips of jump leads and motorcycle

Danger of short circuit

- Use jump leads fitted with fully insulated crocodile clips at both ends.

ATTENTION

Jump-starting with a voltage higher than 12 V

Damage to the motorcycle's electronics

- The battery of the donor motorcycle must have a voltage of 12 V.
- Remove the seat. (► 98)
- Do not disconnect the battery from the electrical system for an external start.

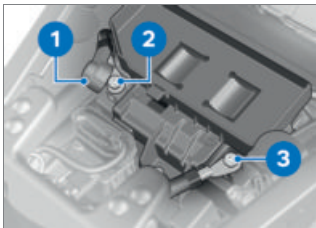

- Open positive terminal cover **1**.

- Begin by connecting one end of the red jumper cable to the positive terminal **2** of the discharged battery and the other end to the positive terminal of the donor battery.
- Then clamp one end of the black jumper cable to the donor battery's negative terminal **3** while connecting the other end to the empty battery's negative terminal.
- Run the engine of the donor vehicle during the jump-starting procedure.
- Start the engine of the vehicle with the empty battery in the usual way; if the engine does not start, wait a few minutes before repeating the attempt to start the engine to protect the starter motor and the donor battery.
- Allow both engines to idle for a few minutes before disconnecting the jumper cable.
- Disconnect the jumper cable from the negative terminal first, then from the positive terminal.

 To start the engine, do not use start sprays or similar items.

- Install the seat. (▶▶▶ 99)

BATTERY

Maintenance instructions

Proper care, charging and storage extend the battery's service life and are required for any warranty claims.

Compliance with the points below is important in order to maximize battery service life:

- Keep the surface of the battery clean and dry.
- Do not open the battery.
- Do not top up with water.
- Be sure to read and comply with the instructions for charging the battery on the following pages.
- Do not turn the battery upside down.



Battery design

AGM (Absorbent Glass Mat) battery, maintenance-free



ATTENTION

Discharging of the connected battery by the vehicle electronics (e.g. clock)

Total discharge of battery leading to a rejection of warranty claims

- During riding breaks of more than 4 weeks, connect a trickle-charger to the battery.



BMW Motorrad has developed a trickle-charger specially designed for compatibility with the electronics of the motorcycle. This device can be used to keep the battery charged during long periods when the motorcycle is not being used even while the battery is connected to the motorcycle. For more information, contact an authorized BMW Motorrad dealer.

Charging connected battery

- Remove devices connected to onboard power sockets.



ATTENTION

Charging the battery connected to the vehicle using the battery terminals

Damage to the motorcycle's electronics

- Disconnect the battery before charging on the battery terminals.



ATTENTION

Improper battery chargers connected to a socket

Damage to battery charger and vehicle electronics

- Use suitable BMW battery chargers. You can obtain the right charger from your authorized BMW Motorrad dealer.

**ATTENTION**

A fully discharged battery must be charged via a power socket or extra socket.

Damage to vehicle electronics

- A fully discharged battery (battery voltage less than 12 V, indicator lights and multifunction display remain off when ignition is switched on) must always be charged directly at the poles of the **disconnected** battery.

- Charge connected battery via onboard power socket.



The vehicle electronics detect when the battery is fully charged. The onboard socket is switched off when this happens.

- Comply with operating instructions of charger.



If you are unable to charge the battery via the onboard power socket, you may be using a charger that is not compatible with your motorcycle's electronics. In this case, charge the battery directly from the terminals of

the battery disconnected from the vehicle.

Charging disconnected battery

- Disconnect the battery.
- Charge battery using a suitable charger.
- Comply with operating instructions of charger.
- After charging, remove the terminal clips of the charger from the battery poles.



In the case of longer periods when the motorcycle is not being used, the battery must be recharged regularly. See the instructions for caring for your battery. Always fully recharge the battery before returning it to use.

Removing the battery

- Park the motorcycle, making sure the ground is level and firm.
- Remove the seat. (→ 98) –with anti-theft alarm system (DWA)^{OE}
- Turn off the anti-theft alarm system if necessary.◁
- Remove the onboard vehicle tool kit.
- Turn off the ignition.

186 MAINTENANCE

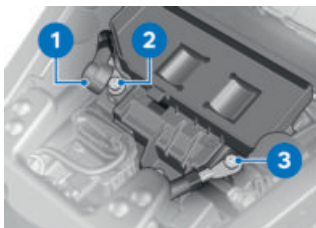

ATTENTION

Incorrect battery disconnection

Danger of short circuit

- Follow the disconnection sequence.
- Remove the negative battery cable **3**.
- Open the positive terminal cover **1**.
- Remove the positive battery cable **2**.

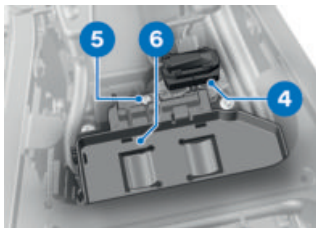

- Loosen diagnostic socket **4** from holder.

- Remove the screw **5** and take the battery cover **6** out toward the front.
- Lift the battery up and out, using tilting movements if the movement is stiff.

Installing the battery



If the vehicle has been disconnected from the battery for a long time, the current date must be reset to make sure the service display is working properly.

- Turn off the ignition.
- Insert the battery into the battery compartment with positive terminal on the right in the riding direction.

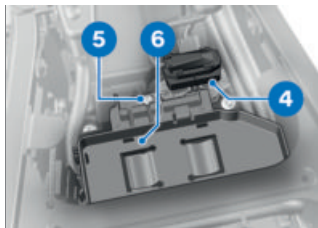

- Install the battery cover **6**.
- Install screw **5**.



Battery carrier on rear wheel cover

M5 x 12

1 lb/ft (2 Nm)

- Fasten diagnostic sockets **4** in holder.

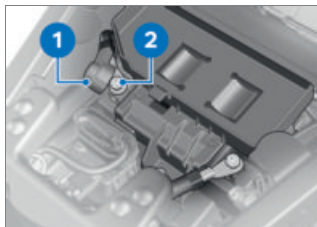

ATTENTION

Incorrect battery connection

Danger of short circuit

- Follow the installation sequence.

- Install positive battery cable **2**.



Wiring harness on battery

M6 x 13.5

4 lb/ft (5 Nm)

- Position the positive terminal cover **1**.

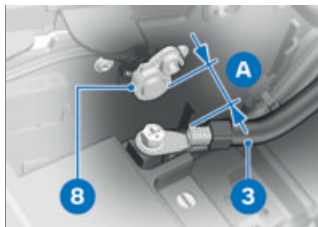

- Install the negative battery cable **3**, making sure there is a sufficient distance **A** between the negative battery cable and the seat locking lever **8**.



Wiring harness on battery

M6 x 13.5

4 lb/ft (5 Nm)

- Install the onboard toolkit.
- with anti-theft alarm system (DWA)^{OE}
- Turn on the anti-theft alarm system if necessary. ◁
- Install the seat. (▮▮▮ 99)
- Configure system settings. (▮▮▮ 66)

188 MAINTENANCE

FUSES

Replacing the main fuse

ATTENTION

Bypassing defective fuses

Risk of short circuit and fire

- Do not bypass defective fuses.
 - Replace defective fuses with new fuses.
- Turn off the ignition.
 - Park the motorcycle, making sure the ground is level and firm.
 - Remove the seat. (➔ 98)



- Replace faulty fuse **1**.

 If the fuses are faulty frequently, have the electrical system checked by a repair shop, preferably an authorized BMW Motorrad dealer.



Main fuse

40 A (Voltage regulator)

- Install the seat. (➔ 99)

Replacing fuses

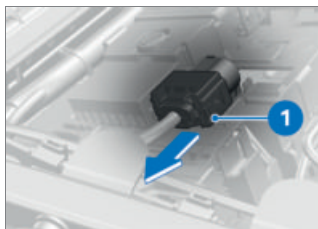

- Turn off the ignition.
- Remove the seat. (➔ 98)
- Pull off the fuse box **1**.

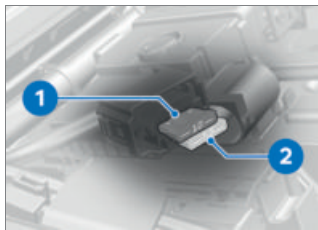

ATTENTION

Bypassing defective fuses

Risk of short circuit and fire

- Do not bypass defective fuses.
 - Replace defective fuses with new fuses.
- Replace the faulty fuse **1** or **2** according to its assignment.

 If the fuses are faulty frequently, have the electrical system checked by a repair shop, preferably an authorized BMW Motorrad dealer.



Fuse box

10 A (Slot 1: Instrument cluster, anti-theft alarm system (DWA), ignition lock, diagnostic socket, coil for main relay)

7.5 A (Slot 2: Left multifunction switch, Tire Pressure Control (TPC))



Fuses

All electrical circuits are electronically protected. If an electric circuit was switched off by the electronic fuse and if the fault that caused this has been rectified, the electric circuit will be active again after switching on the ignition.

- Insert the fuse box.
- Install the seat. (► 99)

DIAGNOSTIC CONNECTOR

Detaching the diagnostic connector



CAUTION

Incorrect procedure when disconnecting the diagnostic socket for onboard diagnosis

Vehicle experiences malfunctions

- Do not have the diagnostic socket disconnected except during BMW Motorrad service by a repair shop or other authorized persons.
- Have work carried out by appropriately trained personnel.
- Observe the specifications of the vehicle manufacturer.

- Remove the seat. (► 98)

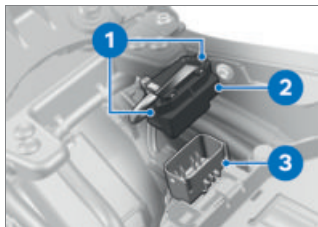

- Press locks **1** on both sides.
- Detach the diagnostic socket **2** from the holder **3**.

190 MAINTENANCE

- » The interface for the diagnostics and information system can be connected to the diagnostic connector **2**.

Fastening the diagnostic connector

- Disconnect the interface for the diagnostics and information system.

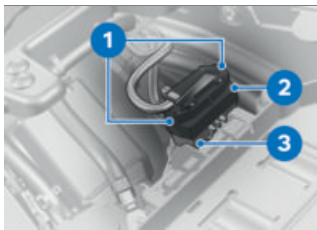

- Insert the diagnostic socket **2** into the holder **3**.
- » The locks **1** snap in.
- Install the seat. (▣▶ 99)

ACCESSORIES

10

GENERAL NOTES	194
SOCKETS	194
USB CHARGING SOCKET	195
CASE	196
NAVIGATION SYSTEM	198

GENERAL NOTES



CAUTION

Use of products from other manufacturers

Safety risk

- BMW Motorrad cannot examine or test each product of outside origin to ensure that it can be used on or in connection with BMW motorcycles without constituting a safety hazard. Nor is this guarantee provided when the official approval of a specific country has been granted. Tests conducted by these instances cannot make provision for all operating conditions experienced by BMW motorcycles and, consequently, they are not sufficient in some circumstances.
- Use only parts and accessories approved by BMW for your motorcycle.

The safety, function and suitability of the parts and accessory products have been thoroughly tested by BMW. Therefore, BMW assumes responsibility for these products. BMW shall not be held liable for un-

approved parts and accessory products of any kind.

Comply with the legal requirements for any modifications.

Consult the road traffic licensing regulations of your country.

Your authorized

BMW Motorrad dealer

offers you qualified advice for choosing original BMW parts, accessories and other products.

More information on the topic of accessories is available at:

bmw-motorrad.com/equipment

SOCKETS

Notes on using onboard power sockets:

Automatic shutoff

Power outlets are switched off automatically in the following circumstances:

- If the battery voltage is too low to retain the starting capability of the vehicle.
- If the maximum load specified in the technical data is exceeded.
- During the starting procedure.
- The sockets are supplied with current for only 60 seconds after the ignition is turned off.

Operating electrical accessories

The ignition must be switched on before any accessories connected to the power sockets can be operated.

Accessories with low electrical consumption might not be detected by the vehicle electronics. In these cases, onboard sockets are already turned off shortly after the ignition is turned off.

Cable layout

Observe the following when routing cable from power sockets to additional devices:

- Cables must not impede the rider.
- Cables must not restrict the steering angle and handling characteristics.
- Cables must not become trapped.

USB CHARGING SOCKET

Notes about use:

Charge current

This is a 5 V USB charging socket providing a maximum charge current of 2.4 A.

Automatic shut-off

The USB charging sockets are automatically switched off under the following conditions:

- To retain the starting capability if the battery voltage is too low.
- If the maximum load capacity specified in the technical data is exceeded.
- During the starting procedure.

Connection of electrical devices

The ignition must be switched on before electrical devices connected to USB charging sockets can be operated. To reduce loads on the electrical system, these are switched off no more than 15 minutes after the ignition is switched off.

To protect the connected device, the device should be unplugged when riding in rain. When no device is connected, the cover should be closed to prevent soiling.

Cable routing

Observe the following when routing cables from USB charging sockets to additional devices:

196 ACCESSORIES

- Cables must not impede the rider.
- Cables must not restrict the steering angle and handling characteristics.
- Cables must not become trapped.

CASE

Opening a case

-with aluminum case^{OA}

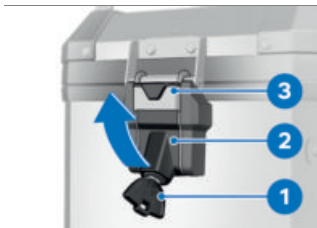

- Turn key **1** counterclockwise.

 The case cover can be opened with both the left and the right latch.

- Press the lock housing **2** upwards to unlock the locking claw **3**.
- Pull the locking claw **3** backward and open the lid.

Closing a case

-with aluminum case^{OA}



- Close the case lid.
- Put the locking claw **1** on the lid.
- Push down lock housing **2**, in doing so ensure that the claw catches in the lid.
- To lock the lock, turn the key **3** clockwise and remove it.

Removing the case lid

-with aluminum case^{OA}

- Open case. (→ 196)



- Detach the lid-retaining cable **1**.
- Close the case lid.
- Open the second closure of the case lid.

- Remove case lid.

Installing the case lid

—with aluminum case^{OA}

- Put the case lid on the case.
- Close one closure of the case lid.
- Open the case lid toward the closed side.



- Attach the lid-retaining cable **1**.
- Close the case lid.
- Close the second closure of the case lid.

Removing a case

—with aluminum case^{OA}

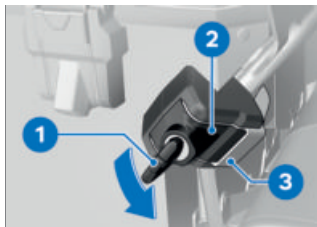

- Turn key **1** counterclockwise.

- Push the lock housing **2** to the side to unlock the locking claw **3**.
- Pull locking claw **3** to the side while holding the case in position.
- Pull the case forward up to the stop and remove it sideways.

Attaching a case

—with aluminum case^{OA}

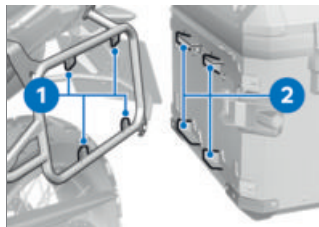

- Place case on case carrier and slide backwards so that mounts on case carrier **1** and case **2** interlock.

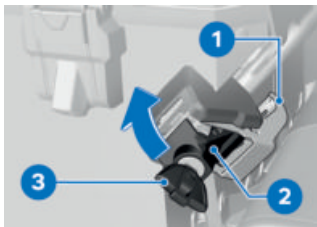

- Put the locking claw **1** on the case carrier while holding the case in position.
- Push lock housing **2** to one side, in doing so make sure that the claw grips around the holder.
- Turn the key clockwise and remove it.

Maximum payload and maximum speed

Observe maximum payload and maximum speed.



Maximum speed for riding with case

max 99 mph (max 160 km/h)



Payload per case

max 18 lbs (max 8 kg)

NAVIGATION SYSTEM

–with preparation for navigation system^{OE}

Securely fastening navigation device



The navigation preparation is suitable for BMW Motorrad Navigator IV and later.



The locking system of the Mount Cradle offers no protection against theft. Remove the navigation system and store in a safe place after every drive.

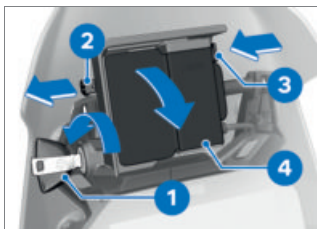

- Turn the ignition key **1** counterclockwise.
- Pull the shut-off lock **2** to the **left**.
- Press in the locking mechanism **3**.
- » The Mount Cradle is unlocked and the cover **4** can be removed with a rotational movement toward the front.

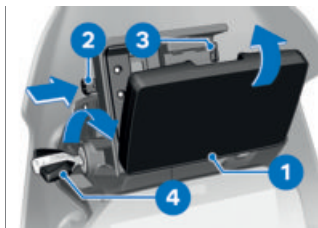

- Mount the navigation device **1** in the lower area and swing backward with a rotational movement.
 - » Navigation device audibly engages.
- Slide the shut-off lock **2** completely to the **right**.
 - » The locking mechanism **3** is locked.
- Turn the ignition key **4** clockwise.
 - » The navigation device is locked.
- Pull out the ignition key **4**.

Removing the navigation device and installing the cover



ATTENTION

Dust and dirt on the contacts of the Mount Cradle

Damage to the contacts

- Reinstall the cover after end of each drive.

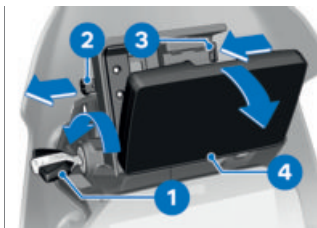

- Turn the ignition key **1** counterclockwise.
- Pull the lock safety device **2** all the way to the **left**.
 - » The locking mechanism **3** is unlocked.
- Slide the lock **3** all the way to the **left**.
 - » Navigation device **4** is unlocked.
- Remove navigation device **4** downward with a tilting movement.

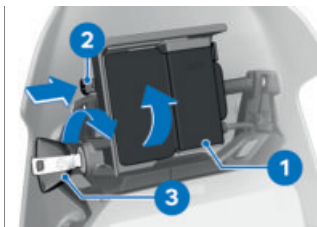



- Mount the cover **1** in the lower area and swing upward with a rotational movement.
 - » Cover audibly engages.

200 ACCESSORIES

- Slide the lock safety device **2** to the **right**.
- Turn the ignition key **3** clockwise.
- » The cover **1** is secured.
- Pull out the ignition key **3**.

Operating the navigation system

 The following description refers to the BMW Motorrad ConnectedRide Navigator.

 Only the latest version of the BMW Motorrad communication system is supported. A software update may be required for the BMW Motorrad communication system. In this case, please contact your authorized BMW Motorrad dealer.

If the BMW Motorrad ConnectedRide Navigator is installed and the operating focus is changed to the Navigator ( 68), some of its functions can be operated directly from the handlebars. If the BMW Motorrad ConnectedRide Navigator is connected, all connections to the vehicle are automatically disconnected and reestablished by the Navigator. Now the Navigation, Media

and Telephone functions are controlled through the Navigator.

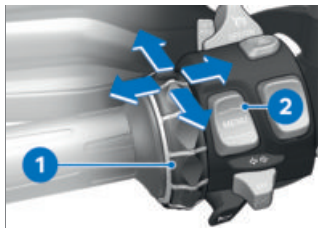

The navigation system is operated using the Multi-Controller **1** and the rocker button **MENU 2**.

Turn the Multi-Controller **1** up/down

- Select menu
- Change volume
- Zoom in when using maps

Briefly tilt the Multi-Controller **1** to the left/right

- Confirm or cancel

Press the rocker button **MENU 2** at the bottom

Change the operating focus to the instrument cluster.

Special functions

The ConnectedRide Navigator is equipped with an automatic operating focus changer. For more information, see the operating instructions of the ConnectedRide Navigator.

Security settings

The safety instructions in the operating instructions of the BMW Motorrad ConnectedRide Navigator must be observed.

CARE

11

CARE PRODUCTS	204
WASHING THE VEHICLE	204
CLEANING SENSITIVE MOTORCYCLE PARTS	205
CARE OF PAINTWORK	206
PAINT PRESERVATION	207
STORING THE MOTORCYCLE	207
PUTTING THE MOTORCYCLE INTO OPERATION	207

CARE PRODUCTS

ATTENTION

Use of unsuitable cleaning and care agents

Damage to motorcycle parts

- Do not use any solvents such as nitro thinners, cold cleaners, fuel or similar, and do not use cleaning agents that contain alcohol.

ATTENTION

Use of highly acidic or alkaline cleaning agents

Damage to motorcycle parts

- Observe the dilution ratio on the packaging of the cleaning agents.
- Do not use highly acidic or alkaline cleaning agents.

BMW Motorrad recommends that you use cleaning and care products available at your authorized BMW Motorrad dealer. BMW Care Products have been materials tested, lab-tested, and field tested and provide optimum vehicle care and protection for the materials used in your vehicle.

WASHING THE VEHICLE

WARNING

Wet brake disks and brake pads after washing the vehicle, after water passages or in rain

Decreased braking effect, risk of accident

- Brake early until the brake disks and brake pads have dried off on their own or through braking.

ATTENTION

Damage caused by high water pressure from high-pressure cleaners or steam-jet devices

Corrosion or short circuit, damage to labels, to seals, to hydraulic brake system, to the electrical system and the seat

- Exercise caution when using high-pressure or steam-jet devices.

BMW Motorrad recommends that you use BMW Insect Remover to soften and wash off insects and stubborn dirt from painted parts before washing the motorcycle.

To prevent stains, do not wash the vehicle immediately after it has been exposed to bright sunlight and do not wash it in the sun.

Regularly clean the fork tubes of contamination.

Make sure that the vehicle is washed more frequently, especially during the winter months and when riding on salted roads.



ATTENTION

Increased effect of salt caused by warm water

Corrosion

- Only use cold water to remove salt deposits.

To remove salt deposits, clean the vehicle and any add-on parts with cold water immediately after completion of every trip.

 After rides in the rain, in high humidity and after the vehicle is washed, condensation can form inside the headlight. During this process, the headlight can become foggy for a while. If moisture accumulates in the headlight on an ongoing basis, contact a

repair shop, preferably an authorized BMW Motorrad dealer.

CLEANING SENSITIVE MOTORCYCLE PARTS

Plastics



ATTENTION

Use of unsuitable cleaning agents

Damage to plastic surfaces

- Do not use abrasive cleaners or cleaners containing alcohol or solvents.
- Do not use insect sponges or sponges with a hard surface.

Clean plastic components with water and BMW plastic care emulsion. This includes in particular:

- Windshields and wind deflectors
- Headlight diffusers made of plastic
- Glass cover of the instrument cluster
- Black, unpainted parts



Soften stubborn dirt and dead insects by covering the affected areas with a wet cloth.

206 CARE

TFT display

Clean the TFT display with warm water and detergent. Then dry with a clean cloth, e.g. a paper towel.

Chrome

Carefully clean chrome parts with plenty of water and motorcycle cleaner of the BMW Care Products series. This is particularly important in case of exposure to salt.

For additional treatment, use BMW Motorrad high-gloss polish.

Radiator

Clean the radiator regularly to prevent overheating of the engine due to inadequate cooling. For example, use a garden hose with low water pressure.



ATTENTION

Bending of radiator fins

Damage to radiator fins

- When cleaning, ensure that the cooler fins are not bent.

Rubber



ATTENTION

Use of silicone sprays for care of rubber seals

Damage to rubber seals

- Do not use silicone sprays or care products that contain silicone.

Treat rubber parts with water or BMW rubber care product.

CARE OF PAINTWORK



ATTENTION

Paint damage from metal polish

Risk of damage

- Do not treat paints and chrome lacquers with metal polish.

Washing the vehicle regularly will help counteract the long-term effects of substances that damage the paint, especially if your vehicle is ridden in areas with high air pollution or natural sources of dirt, such as tree resin or pollen.

However, remove particularly aggressive substances immediately; otherwise changes in the paint or discoloration may occur. These include spilled

fuel, oil, grease and brake fluid as well as bird droppings. It is recommended to use BMW Motorrad solvent cleaner and then apply BMW Motorrad high-gloss polish to preserve the paint.

Contaminants on the paint surface are particularly easy to see after washing the vehicle. Remove this type of dirt immediately with cleaning benzene or ethyl alcohol on a clean cloth or cotton ball. BMW Motorrad recommends removing tar stains with BMW tar remover. Then add a protective wax coating to the paint at these locations.

PAINT PRESERVATION

Apply a preservative when water fails to bead up on the painted surface.

BMW Motorrad recommends BMW Motorrad high gloss polish or agents that contain carnauba or synthetic wax for paint preservation.

 Chrome lacquer must not be preserved with chrome polish. Only use the agents recommended by BMW Motorrad.

STORING THE MOTORCYCLE

- Completely fill the motorcycle's fuel tank.

 Fuel additives clean the fuel injection system and the combustion area. Fuel additives should be used when refueling with low-quality fuels or during longer stationary periods. Your authorized BMW Motorrad dealer can provide you with more detailed information.

- Clean the motorcycle.
- Remove battery.
- Spray the brake lever and clutch lever as well as side stand pivots with a suitable lubricant.
- Coat bare metal and chrome-plated parts with an acid-free grease (petroleum jelly).
- Park motorcycle in a dry room, raising it to relieve weight from both wheels (preferably using the front-wheel and rear-wheel stands offered by BMW Motorrad).

PUTTING THE MOTORCYCLE INTO OPERATION

- Remove the protective wax coating.
- Clean the motorcycle.
- Install the battery.

208 CARE

- Checklist. (→ 118)

TECHNICAL DATA

12

TROUBLESHOOTING CHART	212
THREADED CONNECTIONS	214
FUEL	216
ENGINE OIL	217
ENGINE	217
CLUTCH	218
TRANSMISSION	218
REAR-WHEEL DRIVE	219
FRAME	219
RUNNING GEAR	219
BRAKES	220
WHEELS AND TIRES	221
ELECTRICAL SYSTEM	222
DIMENSIONS	223
WEIGHTS	224
PERFORMANCE DATA	224

212 TECHNICAL DATA

TROUBLESHOOTING CHART

Engine does not start:

Possible cause	Remedy
Side stand extended and gear engaged	Engage neutral or fold in side stand.
Gear engaged and clutch not disengaged	Shift transmission to neutral or disengage clutch.
No fuel in tank	Refueling.
Battery drained	Charge the connected battery.
Overheating protection for starter motor has triggered. Starter motor can only be actuated for a limited period.	Leave the starter motor to cool down for around 1 minute until it becomes available again.

Bluetooth connection is not established.

Possible cause	Remedy
Necessary pairing steps were not performed.	Refer to the operating instructions of the communication system for the necessary steps for pairing.
The communication system is not connected automatically despite successful pairing.	Switch off the communication system of the helmet and connect again after one to two minutes.
Too many Bluetooth devices are stored in the helmet.	Delete all pairing entries in the helmet (see the operating instructions of the communication system).
There are additional vehicles with Bluetooth-capable devices nearby.	Avoid simultaneous pairing with multiple vehicles.

Bluetooth connection is disrupted.

Possible cause	Remedy
Bluetooth connection to the mobile end device is interrupted.	Switch off energy saving mode.
Bluetooth connection to the helmet is interrupted.	Switch off the communication system of the helmet and connect again after one to two minutes.
Volume in the helmet cannot be adjusted.	Switch off the communication system of the helmet and connect again after one to two minutes.

Phone book is not displayed in the TFT display.

Possible cause	Remedy
Phone book was has not yet been transferred to the vehicle.	During pairing to the mobile end device, confirm the transfer of the telephone data (☰➔ 72).

Active route guidance is not displayed in the TFT display.

Possible cause	Remedy
Navigation from the BMW Motorrad Connected App was not transferred.	Call up the BMW Motorrad Connected App on the connected mobile end device before riding.
Route guidance cannot be started.	Ensure that there is a data connection to the mobile end device and check the map data on the mobile end device.

214 TECHNICAL DATA

THREADED CONNECTIONS

Front wheel	Value	Valid
Wheel speed sensor at front on fork		
M6 x 16, Renew bolt micro-encapsulated	6 lb/ft (8 Nm)	
Front wheel cover on telescopic forks		
M6 x 16, Renew bolt micro-encapsulated	2 lb/ft (3 Nm)	
Brake caliper on telescopic forks		
M10 x 45	28 lb/ft (38 Nm)	
Pinch bolt on quick-release axle		
M8 x 35	Tightening sequence: Tighten the screws 6 times, alternating between one and the other each time	
	14 lb/ft (19 Nm)	
Axle screw in front quick-release axle		
M20 x 1.5	37 lb/ft (50 Nm)	
Rear wheel	Value	Valid
Rear wheel speed sensor on the brake caliper carrier		
M6 x 16, Renew bolt micro-encapsulated	6 lb/ft (8 Nm)	

Rear wheel	Value	Valid
Rear-wheel quick-release axle in swinging arm		
M24 x 1.5	92 lb/ft (125 Nm)	
Mirror arm	Value	Valid
Mirror (locknut) on clamping piece		
M10 x 1.25	Left-hand thread, 16 lb/ft (22 Nm)	
Adapter to clamping block		
M10 x 14 - 4.8	18 lb/ft (25 Nm)	

216 TECHNICAL DATA

FUEL

Recommended fuel quality	Premium unleaded (max 15% ethanol, E10/E15) 89 AKI (95 ROZ/RON) 90 AKI
Alternative fuel quality	Regular unleaded (restrictions with regard to power and fuel consumption.) (max 15% ethanol, E10/E15) 87 AKI (91 ROZ/RON) 87 AKI
Usable fuel quantity	Approx. 3.8 gal (Approx. 14.5 l)
Reserve fuel quantity	Approx. 1.1 gal (Approx. 4 l)
Fuel consumption	53 mpg (4.40 l/100 km), in accordance with WMTC
CO2 emissions	103 g/km, In accordance with WMTC
Emission standard	TIER 2

ENGINE OIL

Engine oil, capacity	Approx. 3.2 quarts (Approx. 3.0 l), with filter replacement
Specification	SAE 5W-40, API SL/ JASO MA2, Additives (for instance, molybdenum-based substances) are prohibited, because they would attack the coatings on engine components, BMW Motorrad recommends BMW Motorrad ADVANTEC Ultimate oil.
Oil additives	BMW Motorrad does not recommend the use of oil additives, as these can adversely affect the operation of the clutch. Ask your BMW Motorrad retailer for engine oils suitable for your motorcycle.
Engine oil, quantity for topping up	max 0.5 quarts (max 0.5 l), Difference between MIN and MAX

BMW recommends **ADVANTEC**
ORIGINAL BMW ENGINE OIL

ENGINE

Engine number location	Upper part of crankcase, close to oil heat exchanger
Engine type	A24A09B

218 TECHNICAL DATA

Engine design	Water-cooled 2-cylinder four-stroke engine with four valves (operated via rocker arms) per cylinder, two overhead camshafts and dry-sump lubrication
Displacement	895 cc (895 cm ³)
Cylinder bore	3.4 in (86 mm)
Piston stroke	3 in (77 mm)
Compression ratio	13.1:1
Nominal capacity	103 hp (77 kW), at RPM: 8500 min ⁻¹
Torque	69 lb/ft (93 Nm), at RPM: 6750 min ⁻¹
Maximum engine speed	max 9250 min ⁻¹
Idle speed	1250 ^{±50} min ⁻¹ , Engine at operating temperature

CLUTCH

Clutch design	Multiple-disc oil bath (anti-hopping)
---------------	---------------------------------------

TRANSMISSION

Transmission design	Claw-shifted 6-speed manual gearbox integrated in engine housing
---------------------	--

REAR-WHEEL DRIVE

Type of final drive	Chain drive
Secondary gear ratio	2.765 (47/17 teeth)
Transmission gear ratios	1.821, Primary gear ratio

FRAME

Frame design	Steel bridge frame in shell construction
Location of type plate	Frame at front left on steering head
Location of the vehicle identification number	Front right frame next to steering head

RUNNING GEAR**Front wheel**

Spring travel, front	9.1 in (230 mm), on front wheel
-with lowered ^{OE}	8.3 in (210 mm), on front wheel

Rear wheel

Type of rear-wheel guide	Two-arm aluminum swinging arm
Spring travel on the rear wheel	8.5 in (215 mm), on rear wheel
-with lowered ^{OE}	7.7 in (195 mm), on rear wheel

220 TECHNICAL DATA

BRAKES

Front wheel

Type of front wheel brake	Hydraulically operated twin disc brake with 2-piston floating calipers and floating brake discs
Front brake pad material	Sintered metal
Front brake disc thickness	0.18 in (4.5 mm), New condition min 0.16 in (min 4.0 mm), Wear limit
Free travel of brake actuation (Front wheel brake lever)	0.03...0.07 in (0.7...1.7 mm), measured at the piston

Rear wheel

Type of rear wheel brake	Hydraulically operated disc brake with 1-piston floating caliper and fixed brake disk
Rear brake pad material	Organic
Rear brake disc thickness	0.2 in (5.0 mm), New condition min 0.18 in (min 4.5 mm), Wear limit
Blow-by clearance of foot-brake lever	0.07...0.08 in (1.9...2.1 mm), At the end stop of the foot brake lever on the footrest plate.

WHEELS AND TIRES

Recommended tire combinations	An overview of the current tire approvals is available from your authorized BMW Motorrad dealer.
Speed category of front/rear tires	V, minimum requirement: 149 mph (240 km/h)
-with off-road tires ^{OE}	Q, Alternative speed category: 99 mph (160 km/h)

Front wheel

Front wheel design	Cross spoke wheel
Front-wheel rim size	2.15" x 21"
Front tire designation	90/90-21
Load index for front tire	At least 54
Permissible front-wheel imbalance	max 0.2 oz (max 5 g)

Rear wheel

Rear wheel design	Cross spoke wheel
Rear-wheel rim size	4.25" x 17"
Rear tire designation	150/70 R 17
Load index for rear tire	At least 69
Permissible rear-wheel imbalance	max 0.2 oz (max 5 g)

222 TECHNICAL DATA

Tire pressure

Front tire pressure	31.9 psi (2.2 bar), One-up mode, with cold tires 36.3 psi (2.5 bar), Two-up and/or load, with cold tire
Rear tire pressure	36.3 psi (2.5 bar), One-up mode, with cold tires 42.1 psi (2.9 bar), Two-up and/or load, with cold tire

ELECTRICAL SYSTEM

Main fuse	40 A, Voltage regulator
Fuse box	10 A, Slot 1: Instrument cluster, anti-theft alarm system (D-WA), ignition lock, diagnostic socket, coil for main relay 7.5 A, Slot 2: Left multifunction switch, Tire Pressure Control (TPC)
Electrical rating of onboard sockets	max 5 A, all on-board power sockets in total

Battery

Battery design	AGM (Absorbent Glass Mat) battery, maintenance-free
Battery voltage	12 V
Battery capacity	9 Ah
Battery type (For Keyless Ride radio-operated key)	
–with Keyless Ride ^{OE}	CR 2032

Spark plugs

Spark plugs, manufacturer and designation	NGK LMAR9J-9E
---	---------------

All light sources	LED
-------------------	-----

DIMENSIONS

Motorcycle length	89.4 in (2270 mm), over license-plate carrier
Motorcycle height	54.8 in (1393 mm), over windshield, at DIN unloaded vehicle weight
-with windshield, high ^{OE} or -with windshield, high ^{OA}	57.1 in (1450 mm), over windshield, at DIN unloaded vehicle weight
Motorcycle width	37.1 in (943 mm), without installed parts
Front-seat height	34.3 ^{+0.8} _{-1.4} in (870 ⁺²⁰ ₋₃₅ mm), Without rider, at DIN unloaded vehicle weight
-with lowered ^{OE}	32.9 in (835 mm), Without rider, at DIN unloaded vehicle weight
Rider's inside-leg arc, heel to heel	76.2 ^{+1.2} _{-1.4} in (1935 ⁺³⁰ ₋₃₅ mm), at DIN unloaded vehicle weight; without rider
-with lowered ^{OE}	73.2 in (1860 mm), at DIN unloaded vehicle weight; without rider

224 TECHNICAL DATA

WEIGHTS

Unloaded vehicle weight	483 lbs (219 kg), DIN unloaded vehicle weight, ready for road, fuel tank 90% full, without OE
Gross vehicle weight	981 lbs (445 kg)
Maximum payload	498 lbs (226 kg)

PERFORMANCE DATA

Maximum speed	>124 mph (>200 km/h)
-with off-road tires ^{OE}	99 mph (160 km/h)
-with case ^{OA}	99 mph (160 km/h)
-with tank bag ^{OA}	81 mph (130 km/h)

SERVICE

13

REPORTING SAFETY DEFECTS	228
RECYCLING	229
BMW MOTORRAD SERVICE	229
BMW MOTORRAD SERVICE HISTORY	230
BMW MOTORRAD MOBILITY SERVICES	230
MAINTENANCE WORK	230
MAINTENANCE SCHEDULE	232
BMW MOTORRAD BREAK-IN SERVICE	233
MAINTENANCE CONFIRMATIONS	234
SERVICE CONFIRMATIONS	246

REPORTING SAFETY DEFECTS

If you think that your vehicle has a fault which may cause an accident, injury or death, you must inform the NHTSA (National Highway Traffic Safety Administration) immediately and BMW of North America, LLC.

If the NHTSA receives other similar complaints, it may open an investigation. If it finds that a safety defect exists in a group of vehicles, the NHTSA may order the manufacturer to perform a recall and remedy campaign. However, the NHTSA cannot become involved in individual problems between you, your authorized BMW Motorrad dealer or BMW of North America, LLC.

You can contact the NHTSA by calling 1-888-327-4236 to reach the Vehicle Safety Hotline (Teletypewriter TTY for the hearing impaired: 1-800-424-9153) for free, by visiting the website at <http://www.safercar.gov> or by writing to Administrator, NHTSA, 400 Seventh Street, SW., Washington, DC 20590. Further information on vehicle safety is available at the following website: <http://www.safercar.gov>.

Canadian customers who wish to report a safety-related defect to Transport Canada, Defect Investigations and Recalls may call the toll-free hotline 1-800-333-0510. You can also obtain other information about vehicle safety from <http://www.tc.gc.ca/road-safety>.

RECYCLING

Disposal of a vehicle

When the vehicle has reached the end of its life cycle, BMW Motorrad recommends giving it to a collection point designated by the manufacturer.

The respective national legal requirements apply to this collection and recycling in general. Information about recycling and sustainability can be retrieved at the country-specific websites of the manufacturer. More information can be requested from your authorized BMW Motorrad dealer or another qualified service partner or a repair shop.

BMW MOTORRAD SERVICE

With its worldwide dealer network, BMW Motorrad can attend to you and your motorcycle in over 100 countries around the globe. Authorized BMW Motorrad dealers have the technical information and expertise needed to reliably conduct all preventive maintenance and repair procedures on your BMW.

You will find the nearest authorized BMW Motorrad

dealer at our website:
bmw-motorrad.com.



WARNING

Improperly performed preventive maintenance and repair procedures

Risk of accident due to subsequent damage

- BMW Motorrad recommends having corresponding work performed on the motorcycle by a repair shop, preferably by an authorized BMW Motorrad dealer.

To ensure that your BMW is always in optimum condition, BMW Motorrad recommends that you comply with the maintenance intervals specified for your motorcycle.

Have all preventive maintenance and repair work carried out confirmed in the "Service" chapter in this manual. Documented proof of scheduled preventive maintenance is essential for generous treatment of claims submitted after the warranty period has expired (goodwill).

230 SERVICE

You can obtain information on the contents of the BMW Motorrad Services from your authorized BMW Motorrad dealer.

BMW MOTORRAD SERVICE HISTORY

Entries

Maintenance work that has been performed is recorded in the diagnostics and information system. Like a Service Booklet, these entries provide proof of regular preventive maintenance. If an entry is made in the vehicle's service history, service-related data is stored on the central IT systems that can be accessed via BMW.

When there is a change in vehicle owner, the data entered in the electronic Service History can also be viewed by the new vehicle owner. An authorized BMW Motorrad dealer or repair shop can view the data entered in the service history.

Objection

At an authorized BMW Motorrad dealer or repair shop, the vehicle owner can object to the entry of data in the service history with the related storage of data in the

vehicle and the transfer of data to the vehicle manufacturer during his time as the vehicle owner. In this case, no entry is made in the vehicle's electronic Service History.

BMW MOTORRAD MOBILITY SERVICES

As the owner of a new BMW motorcycle, in the event of a breakdown you can benefit from the protection afforded by the various BMW Motorrad mobility services (e.g. BMW Roadside Assistance, breakdown service, vehicle recovery service).

Contact your authorized BMW Motorrad dealer for additional information on available mobility services.

MAINTENANCE WORK

BMW pre-delivery check

The BMW pre-delivery check is carried out by your authorized BMW Motorrad dealer before it turns the vehicle over to you.

BMW running-in check

The BMW running-in check must be carried out between 300 mi (500 km) and 750 mi (1200 km).

BMW Motorrad Service

BMW Motorrad service is carried out once a year.

The scope of the services performed may be dependent on the age of the vehicle and the distance covered. Your authorized BMW Motorrad dealer confirms that the service has been performed and enters the date for the next service.

For riders with a high annual distance traveled, it may be necessary to come in for service before the entered date. In these cases, a corresponding maximum distance covered will also be entered in the confirmation of service. If this distance covered is reached before the next service appointment, service must be performed sooner.

The service display in the display reminds you of the approaching service appointment approx. one month or 620 mi (1000 km) before the entered values.

More information on the topic of service is available at:

bmw-motorrad.com/service

The required scope of maintenance work for your vehicle can be found in the following maintenance schedule. The listed repair procedures are due at the respective specified mileage levels or the specified time intervals.

232 SERVICE

MAINTENANCE SCHEDULE

	500 -1200 km 300 - 750 mls	10 000 km 6 000 mls	20 000 km 12 000 mls	30 000 km 18 000 mls	40 000 km 24 000 mls	50 000 km 30 000 mls	60 000 km 36 000 mls	70 000 km 42 000 mls	80 000 km 48 000 mls	90 000 km 54 000 mls	100 000 km 60 000 mls	12 months	24 months
1	X												
2		X	X	X	X	X	X	X	X	X	X	X ^a	
3		X	X	X	X	X	X	X	X	X	X	X ^a	
4			X		X		X		X		X		
5			X		X		X		X		X		
6			X		X		X		X		X		
7		X ^b	X ^b	X ^b	X ^b	X ^b	X ^b	X ^b	X ^b	X ^b	X ^b	X ^b	
8				X			X			X			
9												X ^c	X ^c

- 1 BMW Motorrad break-in inspection (including oil and oil filter change)
- 2 Standard scope of BMW Motorrad service
- 3 Engine oil change with filter
- 4 Check valve clearance
- 5 Replace all spark plugs
- 6 Replace the air filter insert
- 7 Check or replace the air filter element
- 8 Oil change in the telescopic forks
- 9 Change brake fluid in the entire system

^a Annually or every 6000 mi (10000 km) (whichever comes first)

^b For offroad use

^c At first after one year, then every two years

BMW MOTORRAD BREAK-IN SERVICE

BMW Motorrad break-in service

The BMW Motorrad break-in service repair procedures are listed below. The actual scope of maintenance required for your vehicle may differ.

- Performing the vehicle test using the BMW Motorrad diagnostic system
- Adjusting the steering-head bearing
- Engine oil change with filter conversion (oil filter long)
- Checking the coolant level
- Checking the front brake fluid level
- Checking the rear brake fluid level
- Checking/adjusting clutch play
- Checking the chain sag and lubricating the drive chain
- Check the tension of the spokes and tighten as needed
- Checking tire pressure
- Checking the lighting and signal system
- Functional check for engine starting suppression
- Final inspection and road safety check
- Performing the vehicle test using the BMW Motorrad diagnostic system
- Setting the service due date and remaining distance before next service using the BMW Motorrad diagnostic system
- Confirming the BMW service in the vehicle literature

MAINTENANCE CONFIRMATIONS

BMW Motorrad Service standard scope

The repair procedures belonging to the BMW Motorrad Service standard package are listed below. The actual maintenance work applicable for your vehicle may differ.

- Performing the vehicle test using the BMW Motorrad diagnostic system
- Checking the coolant level
- Checking/adjusting clutch play
- Checking the front brake pads and brake discs for wear
- Checking the rear brake pads and brake disc for wear
- Checking the front and rear brake fluid level
- Visual inspection of the brake lines, brake hoses and connections
- Checking the tire pressure and tread depth
- Check the tension of the spokes and tighten as needed
- Checking and lubricating the chain drive
- Checking side stand for ease of movement
- Checking center stand for ease of movement
- Checking steering-head bearing
- Checking the lighting and signal system
- Functional check for engine starting suppression
- Final inspection and road safety check
- Performing the vehicle test using the BMW Motorrad diagnostic system
- Set the service date and remaining distance using the BMW Motorrad diagnostic system
- Checking charging state of battery
- Confirming the BMW Motorrad service in the vehicle literature

BMW Motorrad pre-delivery check

performed

on _____

Stamp, signature

BMW Motorrad break-in service

performed

on _____

at km _____

Next service

latest

on _____

or, if reached earlier

at km _____

Stamp, signature

236 SERVICE

BMW Motorrad Service

performed

on _____

at km _____

Next service

latest

on _____

or, if reached earlier

at km _____

Work performed

	Yes	No
BMW Motorrad Service	<input type="checkbox"/>	<input type="checkbox"/>
Oil change in engine with filter	<input type="checkbox"/>	<input type="checkbox"/>
Checking valve clearance	<input type="checkbox"/>	<input type="checkbox"/>
Replacing all spark plugs	<input type="checkbox"/>	<input type="checkbox"/>
Replacing air filter insert	<input type="checkbox"/>	<input type="checkbox"/>
Checking or replacing air filter insert (during preventive maintenance)	<input type="checkbox"/>	<input type="checkbox"/>
Oil change in telescopic fork	<input type="checkbox"/>	<input type="checkbox"/>
Changing brake fluid in entire system	<input type="checkbox"/>	<input type="checkbox"/>

Notes

Stamp, signature

BMW Motorrad Service

performed

on _____

at km _____

Next service

latest

on _____

or, if reached earlier

at km _____

Work performed

	Yes	No
BMW Motorrad Service	<input type="checkbox"/>	<input type="checkbox"/>
Oil change in engine with filter	<input type="checkbox"/>	<input type="checkbox"/>
Checking valve clearance	<input type="checkbox"/>	<input type="checkbox"/>
Replacing all spark plugs	<input type="checkbox"/>	<input type="checkbox"/>
Replacing air filter insert	<input type="checkbox"/>	<input type="checkbox"/>
Checking or replacing air filter insert (during preventive maintenance)	<input type="checkbox"/>	<input type="checkbox"/>
Oil change in telescopic fork	<input type="checkbox"/>	<input type="checkbox"/>
Changing brake fluid in entire system	<input type="checkbox"/>	<input type="checkbox"/>

Notes

Stamp, signature

238 SERVICE

BMW Motorrad Service

performed

on _____

at km _____

Next service

latest

on _____

or, if reached earlier

at km _____

Work performed

	Yes	No
BMW Motorrad Service	<input type="checkbox"/>	<input type="checkbox"/>
Oil change in engine with filter	<input type="checkbox"/>	<input type="checkbox"/>
Checking valve clearance	<input type="checkbox"/>	<input type="checkbox"/>
Replacing all spark plugs	<input type="checkbox"/>	<input type="checkbox"/>
Replacing air filter insert	<input type="checkbox"/>	<input type="checkbox"/>
Checking or replacing air filter insert (during preventive maintenance)	<input type="checkbox"/>	<input type="checkbox"/>
Oil change in telescopic fork	<input type="checkbox"/>	<input type="checkbox"/>
Changing brake fluid in entire system	<input type="checkbox"/>	<input type="checkbox"/>

Notes

Stamp, signature

BMW Motorrad Service

performed

on _____

at km _____

Next service

latest

on _____

or, if reached earlier

at km _____

Work performed

	Yes	No
BMW Motorrad Service	<input type="checkbox"/>	<input type="checkbox"/>
Oil change in engine with filter	<input type="checkbox"/>	<input type="checkbox"/>
Checking valve clearance	<input type="checkbox"/>	<input type="checkbox"/>
Replacing all spark plugs	<input type="checkbox"/>	<input type="checkbox"/>
Replacing air filter insert	<input type="checkbox"/>	<input type="checkbox"/>
Checking or replacing air filter insert (during preventive maintenance)	<input type="checkbox"/>	<input type="checkbox"/>
Oil change in telescopic fork	<input type="checkbox"/>	<input type="checkbox"/>
Changing brake fluid in entire system	<input type="checkbox"/>	<input type="checkbox"/>

Notes

Stamp, signature

240 SERVICE

BMW Motorrad Service

performed

on _____

at km _____

Next service

latest

on _____

or, if reached earlier

at km _____

Work performed

	Yes	No
BMW Motorrad Service	<input type="checkbox"/>	<input type="checkbox"/>
Oil change in engine with filter	<input type="checkbox"/>	<input type="checkbox"/>
Checking valve clearance	<input type="checkbox"/>	<input type="checkbox"/>
Replacing all spark plugs	<input type="checkbox"/>	<input type="checkbox"/>
Replacing air filter insert	<input type="checkbox"/>	<input type="checkbox"/>
Checking or replacing air filter insert (during preventive maintenance)	<input type="checkbox"/>	<input type="checkbox"/>
Oil change in telescopic fork	<input type="checkbox"/>	<input type="checkbox"/>
Changing brake fluid in entire system	<input type="checkbox"/>	<input type="checkbox"/>

Notes

Stamp, signature

BMW Motorrad Service

performed

on _____

at km _____

Next service

latest

on _____

or, if reached earlier

at km _____

Work performed

	Yes	No
BMW Motorrad Service	<input type="checkbox"/>	<input type="checkbox"/>
Oil change in engine with filter	<input type="checkbox"/>	<input type="checkbox"/>
Checking valve clearance	<input type="checkbox"/>	<input type="checkbox"/>
Replacing all spark plugs	<input type="checkbox"/>	<input type="checkbox"/>
Replacing air filter insert	<input type="checkbox"/>	<input type="checkbox"/>
Checking or replacing air filter insert (during preventive maintenance)	<input type="checkbox"/>	<input type="checkbox"/>
Oil change in telescopic fork	<input type="checkbox"/>	<input type="checkbox"/>
Changing brake fluid in entire system	<input type="checkbox"/>	<input type="checkbox"/>

Notes

Stamp, signature

242 SERVICE

BMW Motorrad Service

performed

on _____

at km _____

Next service

latest

on _____

or, if reached earlier

at km _____

Work performed

	Yes	No
BMW Motorrad Service	<input type="checkbox"/>	<input type="checkbox"/>
Oil change in engine with filter	<input type="checkbox"/>	<input type="checkbox"/>
Checking valve clearance	<input type="checkbox"/>	<input type="checkbox"/>
Replacing all spark plugs	<input type="checkbox"/>	<input type="checkbox"/>
Replacing air filter insert	<input type="checkbox"/>	<input type="checkbox"/>
Checking or replacing air filter insert (during preventive maintenance)	<input type="checkbox"/>	<input type="checkbox"/>
Oil change in telescopic fork	<input type="checkbox"/>	<input type="checkbox"/>
Changing brake fluid in entire system	<input type="checkbox"/>	<input type="checkbox"/>

Notes

Stamp, signature

BMW Motorrad Service

performed

on _____

at km _____

Next service

latest

on _____

or, if reached earlier

at km _____

Work performed

	Yes	No
BMW Motorrad Service	<input type="checkbox"/>	<input type="checkbox"/>
Oil change in engine with filter	<input type="checkbox"/>	<input type="checkbox"/>
Checking valve clearance	<input type="checkbox"/>	<input type="checkbox"/>
Replacing all spark plugs	<input type="checkbox"/>	<input type="checkbox"/>
Replacing air filter insert	<input type="checkbox"/>	<input type="checkbox"/>
Checking or replacing air filter insert (during preventive maintenance)	<input type="checkbox"/>	<input type="checkbox"/>
Oil change in telescopic fork	<input type="checkbox"/>	<input type="checkbox"/>
Changing brake fluid in entire system	<input type="checkbox"/>	<input type="checkbox"/>

Notes

Stamp, signature

244 SERVICE

BMW Motorrad Service

performed

on _____

at km _____

Next service

latest

on _____

or, if reached earlier

at km _____

Work performed

	Yes	No
BMW Motorrad Service	<input type="checkbox"/>	<input type="checkbox"/>
Oil change in engine with filter	<input type="checkbox"/>	<input type="checkbox"/>
Checking valve clearance	<input type="checkbox"/>	<input type="checkbox"/>
Replacing all spark plugs	<input type="checkbox"/>	<input type="checkbox"/>
Replacing air filter insert	<input type="checkbox"/>	<input type="checkbox"/>
Checking or replacing air filter insert (during preventive maintenance)	<input type="checkbox"/>	<input type="checkbox"/>
Oil change in telescopic fork	<input type="checkbox"/>	<input type="checkbox"/>
Changing brake fluid in entire system	<input type="checkbox"/>	<input type="checkbox"/>

Notes

Stamp, signature

BMW Motorrad Service

performed

on _____

at km _____

Next service

latest

on _____

or, if reached earlier

at km _____

Work performed

	Yes	No
BMW Motorrad Service	<input type="checkbox"/>	<input type="checkbox"/>
Oil change in engine with filter	<input type="checkbox"/>	<input type="checkbox"/>
Checking valve clearance	<input type="checkbox"/>	<input type="checkbox"/>
Replacing all spark plugs	<input type="checkbox"/>	<input type="checkbox"/>
Replacing air filter insert	<input type="checkbox"/>	<input type="checkbox"/>
Checking or replacing air filter insert (during preventive maintenance)	<input type="checkbox"/>	<input type="checkbox"/>
Oil change in telescopic fork	<input type="checkbox"/>	<input type="checkbox"/>
Changing brake fluid in entire system	<input type="checkbox"/>	<input type="checkbox"/>

Notes

Stamp, signature

RADIO EQUIPMENT TFT INSTRUMENT CLUSTER	249
RADIO EQUIPMENT TYRE PRESSURE CONTROL (RDC)	250
KEYLESS RIDE ECU	250
KEYLESS RIDE KEY	251
RADIO EQUIPMENT ELECTRONIC IMMOBILISER	252
RADIO EQUIPMENT INTELLIGENT EMERGENCY CALL	253

RADIO EQUIPMENT TFT INSTRUMENT CLUSTER

For all Countries without EU

Model name: ICC6.5in Manufacturer

Robert Bosch GmbH
Robert Bosch Str. 200, 31139
Hildesheim, Germany

Technical information

Technical Information

BT operating frq. Range:
2402 - 2480 MHz

BT version: 4.2 (no BTLE)

BT output power: < 4 dBm

WLAN operating frq. Range:
2412 - 2462 MHz

WLAN standards:

IEEE 802.11 b/g/n

WLAN output power:
< 20 dBm

Country

Canada

This device complies with Industry Canada's licence-exempt RSSs and part 15 of the FCC Rules. Operation is subject to the following two conditions:
(1) this device may not cause interference, and
(2) this device must accept any interference, including interference that may cause undesired operation of the device.

Changes or modifications not expressly approved by the party responsible for compliance could void the user's authority to operate the equipment. Le présent appareil est conforme aux CNR d'Industrie Canada applicables aux appareils radio exempts de licence. L'exploitation est autorisée aux deux conditions suivantes :

- (1) l'appareil ne doit pas produire de brouillage, et
- (2) l'appareil doit accepter tout brouillage radioélectrique subi, même si le brouillage est susceptible d'en compromettre le fonctionnement.

United States (USA)

This device complies with Industry Canada's licence-exempt RSSs and part 15 of the FCC Rules. Operation is subject to the following two conditions:
(1) this device may not cause interference, and
(2) this device must accept any interference, including interference that may cause undesired operation of the device. Changes or modifications not expressly approved by the party responsible for compliance

250 APPENDIX

could void the user's authority to operate the equipment.

RADIO EQUIPMENT TYRE PRESSURE CONTROL (RDC)

For all countries without EU

Model name:

Wus moto gen 3

Manufacturer

LDL Technology S.A.S.
Parc Technologique du Canal, 3
rue Giotto, 31520 Ramonville,
France

Technical information

Frequency band: 433,92 MHz
Maximum effective radiated
power: 16,75 dBm

Country

United States (USA)

This device complies with Part 15 of the FCC Rules and Industry Canada licence-exempt RSS standard(s). Operation is subject to the following two conditions:
(1) this device may not cause interference, and
(2) this device must accept any interference received, including interference that may cause undesired operation.
Changes or modifications not expressly approved by the manufacturer could void the

user's authority to operate the equipment.

KEYLESS RIDE ECU

For all Countries without EU

Model name: HUF8485

Manufacturer

Huf Hülsbeck & Fürst GmbH &
Co. KG
Steeger Str. 17, 42551 Vel-
bert, Germany

Technical information

Frequenzy band: 134,45 kHz
Output/Transmission Power:
42 dBµV/m

Country

Canada

This device complies with part 15 of the FCC Rules and Industry Canada licence-exempt RSS standard(s). Operation is subject to the following two conditions:
(1) This device may not cause interference.
(2) This device must accept any interference, including interference that may cause undesired operation of the device.
Le présent appareil est conforme aux CNR d'Industrie Canada applicables aux appareils radio exempts de licence. L'exploitation est

autorisée aux deux conditions suivantes :

- (1) L'appareil ne doit pas produire de brouillage;
- (2) L'utilisateur de l'appareil doit accepter tout brouillage radioélectrique subi, même si le brouillage est susceptible d'en compromettre le fonctionnement.

United States (USA)

This device complies with part 15 of the FCC Rules. Operation is subject to the following two conditions:

- (1) This device may not cause harmful interference.
- (2) This device must accept any interference received, including interference that may cause undesired operation.

CAUTION:

Changes or modifications not expressly approved by the party responsible for compliance could void the user's authority to operate the equipment.

KEYLESS RIDE KEY

For all Countries without EU

Model name: HUF5794

Manufacturer

Huf Hülsbeck & Fürst GmbH & Co. KG
Steeger Str. 17, 42551 Velbert, Germany

Technical information

Frequenzy band: 433,92 MHz
Output/Transmission Power: 10 mW

Country

Canada

This device complies with part 15 of the FCC Rules and Industry Canada licence-exempt RSS standard(s).

Operation is subject to the following two conditions:

- (1) This device may not cause interference.

- (2) This device must accept any interference, including interference that may cause undesired operation of the device.

Le présent appareil est conforme aux CNR d'Industrie Canada applicables aux appareils radio exempts de licence. L'exploitation est autorisée aux deux conditions suivantes :

- (1) L'appareil ne doit pas produire de brouillage;

252 APPENDIX

(2) L'utilisateur de l'appareil doit accepter tout brouillage radioélectrique subi, même si le brouillage est susceptible d'en compromettre le fonctionnement.

United States (USA)

This device complies with part 15 of the FCC Rules.

Operation is subject to the following two conditions:

(1) This device may not cause harmful interference.

(2) This device must accept any interference received, including interference that may cause undesired operation.

CAUTION:

Changes or modifications not expressly approved by the party responsible for compliance could void the user's authority to operate the equipment.

RADIO EQUIPMENT ELECTRONIC IMMOBILISER

For all countries without EU

Model name: EWS 4

Manufacturer

BECOM Electronics GmbH
Technikerstraße 1, A-7442
Hochstraß, Austria

Technical information

Frequency Band: 134 kHz

Transponder: TMS37145/Type
DST80, TMS3705 Transponder
Base Station IC

Output Power: 50 dB μ V/m

Country

Canada

Contains IC:

10430A-MREWS5012

This device complies with part 15 of the FCC Rules and Industry Canada license-exempt RSS standard(s). Operation is subject to the following two conditions:

(1) this device may not cause interference, and

(2) this device must accept any interference received, including interference that may cause undesired operation.

Le présent appareil est conforme aux CNR d'Industrie Canada applicables aux appareils radio exempts de licence. L'exploitation est autorisée aux deux conditions suivantes :

(1) l'appareil ne doit pas produire de brouillage, et

(2) l'utilisateur de l'appareil doit accepter tout brouillage radioélectrique subi, même si le brouillage est susceptible

d'en compromettre le fonctionnement.

United States (USA)

Contains FCC ID:

ODE-MREWS5012

FCC § 15.19 Labelling requirements

This device complies with part 15 of the FCC Rules and Industry Canada's licence-exempt RSS standard(s). Operation is subject to the following two conditions:

- (1) this device may not cause interference, and
- (2) this device must accept any interference received, including interference that may cause undesired operation.

FCC § 15.21 Information to user

Changes or modifications not expressly approved by the party responsible for compliance could void the user's authority to operate the equipment.

RF Exposure Requirements

To comply with FCC RF exposure compliance requirements, the device must be installed to provide a separation distance of at least 20 cm from all persons.

RADIO EQUIPMENT INTELLIGENT EMERGENCY CALL

For all countries without EU

Model name: TL1P22

Manufacturer

LG ELECTRONICS INC.

10, Magokjungang 10-ro, Gangseo-gu Seoul, Republic of Korea

Country

Canada

IC: 2703H-TM04ANNABM1

This equipment complies with IC radiation exposure limits set forth for an uncontrolled environment. This equipment should be installed and operated with minimum distance 3.5 cm between the radiator & your body. Operation is subject to the following two conditions: (1) this device may not cause interference, and (2) this device must accept any interference, including interference that may cause undesired operation of the device.

The manufacturer is not responsible for any radio or tv interference caused by unauthorized modifications to this equipment. Such modifications could void the user's authority to operate the equipment.

254 APPENDIX

Avis d'Industrie Canada sur l'exposition aux rayonnements
Cet appareil est conforme aux limites d'exposition aux rayonnements d'Industrie Canada pour un environnement non contrôlé. Il doit être installé de façon à garder une distance minimale de 3.5 centimètres entre la source de rayonnements et votre corps.

L'exploitation est autorisée aux deux conditions suivantes :

(1) l'appareil ne doit pas produire de brouillage, et

(2) l'appareil doit accepter tout brouillage radioélectrique subi, même si le brouillage est susceptible d'en compromettre le fonctionnement.

Le fabricant n'est pas responsable des interférences radioélectriques causées par des modifications non autorisées apportées à cet appareil. de telles modifications pourrait annuler l'autorisation accordée à l'utilisateur de faire fonctionner l'appareil.

United States (USA)

FCC ID: BEJTM04ANNABM1

This equipment has been tested and found to comply with the limits for a Class B digital device, pursuant to

part 15 of the FCC Rules.

These limits are designed to provide reasonable protection against harmful interference in a residential installation. This equipment generates, uses and can radiate radio frequency energy and, if not installed and used in accordance with the instructions, may cause harmful interference to radio communications. However, there is no guarantee that interference will not occur in a particular installation. If this equipment does cause harmful interference to radio or television reception, which can be determined by turning the equipment off and on, the user is encouraged to try to correct the interference by one or more of the following measures:

- Reorient or relocate the receiving antenna.
- Increase the separation between the equipment and receiver.
- Connect the equipment into an outlet on a circuit different from that to which the receiver is connected.
- Consult the dealer or an experienced radio/ TV technician for help.

Changes or modifications not expressly approved by the grantee of this device could void the user's authority to operate the equipment.

This device complies with Industry Canada's licence-exempt RSSs and part 15 of the FCC Rules. Operation is subject to the following two conditions:

- (1) this device may not cause interference, and
- (2) this device must accept any interference, including interference that may cause undesired operation of the device.

This device complies with FCC radiation exposure limits set forth for an uncontrolled environment. This device should be installed and operated with minimum distance 3.5 cm between the radiating element of this device and the user.

256 INDEX

- A**
 - Abbreviations and symbols, 4
 - ABS
 - Indicator lights, 52, 53
 - Self-diagnosis, 120
 - Technology in detail, 136
 - Ambient temperature, 39
 - Anti-theft alarm system
 - Indicator light, 24
- B**
 - Battery
 - Charging, 184, 185
 - Indicator lights, 40, 41
 - Installing, 186
 - Maintenance instructions, 183
 - Removing, 185
 - Technical data, 222
 - Bluetooth, 66
 - Brake fluid
 - Checking the fill level, 157, 158
 - Reservoir, 19
 - Brake pads
 - Breaking in, 122
 - Check, 155, 156
 - Brakes
 - ABS Pro, 126, 138
 - Adjusting the brake lever, 103
 - Checking function, 154
 - Safety instructions, 125
 - Technical data, 220
 - Break-in, 122
- C**
 - Care
 - Care products, 204
 - Chrome, 206
 - Paint preservation, 207
 - Washing the vehicle, 204
 - Case, 196
 - Chain
 - Checking for wear, 177
 - Lubricating, 175
 - Sag, 176, 177
 - Chassis, 219
 - Check Control, 32
 - Checklist, 118
 - Clutch
 - Adjusting the clutch lever, 103
 - Checking function, 159
 - Play, 159
 - Technical data, 218
 - Coolant
 - Checking the fill level, 160
 - Filling level indicator, 19
 - Topping up, 160
- D**
 - Damping, 18
 - Setting, 107
 - Diagnostic socket
 - Detaching, 189
 - Fastening, 190
 - Position on vehicle, 20
 - Dimensions, 223
 - DTC
 - Indicator lights, 53, 54, 55
 - Operating, 87
 - Self-diagnosis, 121
 - Technology in detail, 139

DWA

- Indicator lights, 43, 44
- Dynamic Brake Control, 144
- Dynamic engine brake control, 141

E

- Electrical system, 222
- Emergency call
 - Automatic, 83, 84
 - Indicator lights, 51
 - Language, 82
 - manual, 82
 - Notes, 11
 - Operating element, 22
- Emergency-off switch
 - Operating, 81
 - Operating element, 22, 23

Engine

- Indicator lights, 45, 46
- Starting, 119
- Technical data, 217
- Engine oil
 - Checking the fill level, 152
 - Oil filler opening, 18
 - Oil level dipstick, 18
 - Technical data, 217
 - Topping up, 154
- Engine temperature, 44

F

- Factory settings, 97
- Fairing, 181
- Footrests, 18, 19
- Frame, 219
- Front wheel stand, 151

Fuel

- Fuel quality, 128
- Refueling, 128, 130, 131
- Technical data, 216
- Fuel filler cap emergency release, 132
- Fuel reserve
 - Indicator lights, 55
- Fuses
 - Position on vehicle, 20
 - Replacing, 188

G

- Gearshift assistant
 - Gear not taught in, 56
 - Riding, 123
 - Technology in detail, 146

H

- Hazard warning flasher, 86
 - Operating element, 21
- Headlight
 - Headlight beam throw, 102
 - Headlight range, 103
- Headlight courtesy delay feature, 85
- Heated grips
 - Operating, 97
 - Operating element, 22, 23
- Horn, 21

I

- Ignition, 76
- Immobilizer, 81
- Indicator lights
 - ABS, 52, 53
 - Anti-theft alarm system, 43
 - DTC, 53, 54, 55
 - DWA, 43, 44

258 INDEX

Emergency call, 51
Engine control, 45, 46
Engine electronics, 45
Engine temperature, 44
External temperature warning, 39
Fuel reserve, 55
Gear not taught in, 56
Instrument cluster, 24
Keyless Ride, 39, 40
Layout, 32
Light control unit failed, 42
Light source faulty, 42
Overview, 28
RDC, 47
Service, 56, 57
Side stand, 51
Tire Pressure Monitor (TPM), 48, 49, 50
Vehicle voltage, 40, 41
Instrument cluster
 Operating, 58, 64
 Operating element, 21
 Overview, 24, 29, 30
 Photodiode, 24

J
Jump-starting, 182

K
Keyless Ride
 Battery dead or radio-operated key lost, 79
 Ignition, 78
 Indicator lights, 39, 40
 Locking the steering lock, 77
 Unlocking the fuel cap, 130, 131
Keys, 76, 77

L
Light sources
 Indicator lights, 42
 Replacing, 181
Lights
 Auxiliary headlights, 86
 Headlight courtesy delay feature, 85
 Headlight flasher, 85
 High beams, 85
 Low beams, 84
 Operating element, 21
 Parking lights, 84
 Roadside parking lights, 85
Loading information, 115
Lowered suspension, 114
Luggage, 115

M
Maintenance confirmations, 234
Maintenance intervals, 230
Maintenance schedule, 232
Media
 Operating, 71
Menu, 61
Mirrors, 102
Mobility Services, 230
Motorcycle
 Care, 202
 Cleaning, 202
 Lashing down, 133
 Parking, 127
 Putting into operation, 207
 Storage, 207
Multifunction switch
 Overview, left, 21
 Overview, right, 22, 23

N

- Navigation
 - Operating, 69

O

- Off-road mode
 - Setting, 88
 - Technology in detail, 142
- Offroad riding, 124
- Onboard vehicle toolkit, 20
- Operating focus, 68
- Outside temperature, 39
- Overview of warning indicators, 34
- Overviews
 - Indicator and warning lights, 28
 - Instrument cluster, 24, 29, 30
 - Left side of vehicle, 18
 - Left-side multifunction switch, 21
 - Right side of vehicle, 19
 - Right-hand multifunction switch, 22, 23
 - Underneath the seat, 20

P

- Pairing, 66
- Parking light, 85
- Passenger grab handle, 18, 19
- Performance data, 224
- Phone
 - Operating, 72
- Pre-Ride-Check, 119
- Pure Ride, 29

R

- Radio-operated key
 - Indicator lights, 39, 40
 - Replacing the battery, 79
 - RDC
 - Indicator lights, 47, 48, 49, 50
 - Technology in detail, 144
 - Rear-wheel drive, 219
 - Rear-wheel stand, 152
 - Recycling, 229
 - Refueling
 - Fuel quality, 128
 - Refueling procedure, 128, 130, 131
 - Riding mode, 88, 91
 - Riding mode preselection, 89
 - Road sign detection, 71
- S**
- Safety information
 - For riding, 114
 - On braking, 125
 - Screw connections, 214
 - Seat
 - Installing, 98
 - Lock, 18
 - Removing, 98
 - Service
 - BMW Motorrad Service, 229
 - Indicator lights, 56, 57
 - Reporting safety defects, 228
 - Service History, 230
 - Shift lever, 104
 - Shifting gears, 32

260 INDEX

Socket

Information on use, 194

Position on vehicle, 18

Spark plugs, 222

Speed control, 92

Speedometer, 24

Spring preload

Adjusting element, 19

Setting, 104

Start

Engine, 119

Operating element, 22, 23

Status bar, top, 64

Steering lock, 76

T

Tachometer, 24

Tachometer, 31

Tires

Breaking-in, 122

Checking tire pressure, 162

Checking tread depth, 162,
163

Maximum speed, 116

Recommendation, 163

Technical data, 221

Tire pressures, 222

Torques, 214

Transmission, 218

Troubleshooting chart, 212

Turn signals, 86

Operating element, 21

Type plate, 19

U

USB charging interface, 18

V

Vehicle identification

number, 19

Vehicle voltage, 40, 41

W

Warning lights

Instrument cluster, 24

Overview, 28

Weights

Payload table, 20

Technical data, 224

Wheels

Checking rims, 163

Checking spokes, 163

Installing, 167, 173

Removing, 164, 171

Size change, 164

Technical data, 221

The descriptions and illustrations in this manual may vary from your own motorcycle's actual equipment, depending upon its equipment level and accessories as well as your specific national version. No claims will be entertained as a result of such discrepancies. Dimensions, weights, fuel consumption and performance data are quoted to the customary tolerances. The right to modify designs, equipment and accessories is reserved. Errors and omissions excepted.

© 2023 Bayerische Motoren Werke Aktiengesellschaft
80788 Munich, Germany
Reprinting, in whole or in part, is only permitted with the written permission of BMW Motorrad, Aftersales. Original Rider's Manual, printed in Germany.



WARNING

Harmful substances

Operating and preventive maintenance of a passenger vehicle or off-road vehicle can expose you to substances such as exhaust gases, carbon monoxide, phthalates and lead, which are known to the State of California to be carcinogenic as well as detrimental to childbirth and reproduction.

- To minimize exposure, avoid breathing exhaust gases, do not put the engine in Neutral except as necessary, service your vehicle in a well-ventilated area and wear gloves or wash your hands frequently when servicing your vehicle.
- Further information is available at:

**[www.P65Warnings.ca.gov/
passenger-vehicle](http://www.P65Warnings.ca.gov/passenger-vehicle)**

Important data for refueling stop:

Fuel

Recommended fuel quality	Premium unleaded (max 15% ethanol, E10/E15) 89 AKI (95 ROZ/RON) 90 AKI
--------------------------	--

Usable fuel quantity	Approx. 3.8 gal (Approx. 14.5 l)
----------------------	----------------------------------

Reserve fuel quantity	Approx. 1.1 gal (Approx. 4 l)
-----------------------	-------------------------------

Tire pressure

Front tire pressure	31.9 psi (2.2 bar), One-up mode, with cold tires 36.3 psi (2.5 bar), Two-up and/or load, with cold tire
---------------------	--

Rear tire pressure	36.3 psi (2.5 bar), One-up mode, with cold tires 42.1 psi (2.9 bar), Two-up and/or load, with cold tire
--------------------	--

You can find further information on all aspects of your vehicle at:
bmw-motorrad.com

