



BMW Motorrad



Rider's Manual (US Model)

**F850GS**

## Motorcycle/Retailer Data

### Motorcycle Data

---

Model

---

Vehicle identification number

---

Color number

---

Initial registration

---

License plate

### Retailer Data

---

Contact in Service

---

Ms./Mr.

---

Phone number

---

Retailer's address/phone number (company stamp)

## **Welcome to BMW**

We are pleased that you have chosen a BMW Motorrad vehicle and welcome you to the family of BMW riders. Familiarize yourself with your new vehicle so that you can ride safely and confidently in all traffic situations.

### **About these Operating Instructions**

Read these Operating Instructions before starting your new BMW. It contains important notes about operating the vehicle that will enable you to make full use of the technical advantages of your BMW.

You will also obtain maintenance and care instructions, which are beneficial to operating and road safety and help retain the value of your vehicle as much as possible.

Documentation confirming performance of maintenance work is a precondition for generous handling of out-of-warranty claims and goodwill warranty treatment. If you should decide to sell your BMW one day, please remember to hand over these Operating Instructions as well. They are an important part of your vehicle.

### **Suggestions and criticism**

Should you have any questions about your vehicle, your authorized BMW Motorrad retailer is always happy to provide you with advice and assistance.

We wish you many miles of safe and enjoyable riding with your BMW

BMW Motorrad.

01 40 9 446 847



# Table of Contents

<b>1 General instructions ....</b>	<b>5</b>	<b>3 Displays .....</b>	<b>23</b>	Antilock Braking System (ABS).....	89
Overview .....	6	Overview of displays .....	24	Traction control (ASC/DTC) .....	91
Abbreviations and symbols .....	6	Overview of displays with connectivity .....	44	Electronic chassis and suspension adjustment (D-ESA) .....	93
Equipment .....	7	Indicator lights with connectivity .....	49	Riding mode .....	96
Technical data .....	7	<b>4 Operation.....</b>	<b>73</b>	PRO riding mode .....	99
Notice concerning current status .....	8	Ignition steering lock .....	74	PRO riding mode with connectivity .....	101
Additional sources of information.....	8	Ignition with Keyless Ride .....	75	Cruise-control system .....	102
Certificates and operating permits .....	8	EWS Electronic immobilizer .....	78	Tire pressure control (TPC/RDC) .....	105
Data memory.....	8	Emergency on/off switch (kill switch) .....	79	Heated grips .....	105
<b>2 Overviews .....</b>	<b>13</b>	Lights .....	80	Seat .....	106
Overall view, left side .....	15	Hazard warning flasher .....	81	Operating Instructions.....	107
General view, right side .....	17	Turn indicators .....	82	<b>5 TFT display .....</b>	<b>109</b>
Underneath the seat .....	18	Multifunction display .....	83	General notes .....	110
Multifunction switch, left .....	19	SETUP .....	85	Principle .....	111
Multifunction switch, right .....	20	Time and date .....	86	Pure Ride view .....	117
Instrument cluster .....	21	General settings on the multifunction display .....	88	General settings.....	118
Instrument cluster with connectivity .....	22			Bluetooth.....	120
				My vehicle .....	123

On-board computer .....	126	<b>8 Riding .....</b>	<b>143</b>	Riding mode .....	168
Navigation .....	126	Safety information .....	144	Tire pressure control	
Media .....	128	Observe checklist .....	147	(TPC/RDC) .....	171
Phone .....	129	If there is a change in the		Gear Shift Assistant .....	172
Display software		load status: .....	147	<b>10 Maintenance .....</b>	<b>175</b>
version .....	130	Before every journey:.....	147	General notes .....	176
Display license informa-		At every third refueling		Tool kit .....	176
tion .....	130	stop: .....	147	Service tool set .....	177
<b>6 Alarm system .....</b>	<b>131</b>	Starting.....	147	Front wheel stand.....	177
Overview .....	132	Running in .....	151	Engine oil .....	178
Activation .....	132	Shifting gears .....	152	Brake system .....	180
Alarm function.....	134	Off-road riding .....	153	Clutch .....	184
Deactivation .....	135	Brakes .....	154	Coolant.....	186
Programming.....	135	Parking your motorcy-		Tires .....	187
<b>7 Setting.....</b>	<b>137</b>	cle.....	156	Wheel rims and tires .....	188
Mirrors .....	138	Refueling .....	156	Wheels .....	189
Headlight.....	138	Securing motorcycle for		Air filter.....	198
Clutch .....	139	transport .....	161	Light sources .....	200
Brakes .....	140	<b>9 Technology in de-</b>		Trim panel compo-	
Spring preload .....	140	<b>tail.....</b>	<b>163</b>	nents.....	203
Damping .....	141	General notes .....	164	Jump-starting .....	203
		Antilock Braking System		Battery .....	205
		(ABS).....	164	Fuses .....	208
		Traction control (ASC/		Diagnostic socket .....	209
		DTC) .....	166	Chain.....	210

<b>11 Accessories .....</b>	<b>213</b>	Rear-wheel drive .....	244	<b>15 Appendix.....</b>	<b>277</b>
General notes .....	214	Frame .....	244	Certificate for electronic immobilizer .....	278
Onboard power outlets....	214	Chassis.....	244	Certificate for Keyless Ride .....	280
Case .....	215	Brakes .....	245	Certificate for tire pressure control .....	282
Topcase.....	218	Wheels and tires .....	246	Certificate for TFT instrument cluster.....	283
Navigation system.....	222	Electrical system .....	248		
<b>12 Care .....</b>	<b>229</b>	Dimensions .....	250		
Care products .....	230	Weights .....	251		
Washing your motorcycle.....	230	Performance data .....	252	<b>16 Index .....</b>	<b>286</b>
Cleaning sensitive motorcycle parts.....	231	<b>14 Service .....</b>	<b>253</b>		
Paint care .....	232	Reporting safety defects .....	254		
Protective wax coating ....	232	BMW Motorrad Service ...	255		
Store motorcycle.....	232	BMW Motorrad Service History .....	255		
Return motorcycle to use .....	233	BMW Motorrad Mobility Services .....	256		
<b>13 Technical data .....</b>	<b>235</b>	Maintenance procedures .....	256		
Troubleshooting chart ....	236	Maintenance schedule ....	259		
Screw connections .....	239	Maintenance confirmations.....	260		
Fuel .....	241	Service confirmations ....	274		
Engine oil .....	241				
Engine .....	242				
Clutch .....	243				
Transmission .....	243				

## **General instructions**

Overview .....	6
Abbreviations and symbols .....	6
Equipment .....	7
Technical data .....	7
Notice concerning current status ....	8
Additional sources of information ....	8
Certificates and operating permits ...	8
Data memory .....	8

## Overview

Chapter 2 of these Operating Instructions will provide you with an initial overview of your motorcycle. All performed maintenance and repair tasks are documented in Chapter 14. Documentation of the maintenance work performed is a prerequisite for generous treatment of claims.

When the time comes to sell your BMW, please remember to hand over these Operating Instructions; they are an important part of the motorcycle.

## Abbreviations and symbols

 **CAUTION** Hazard with low risk. Failure to avoid this hazard can result in minor or moderate injury.

 **WARNING** Hazard with moderate risk. Failure to avoid this hazard can result in death or serious injury.

 **DANGER** Hazard with high risk. Failure to avoid this hazard results in death or serious injury.

 **ATTENTION** Special instructions and precautionary measures. Non-compliance can cause damage to the vehicle or accessories and warranty claims may be denied as a result.

 **NOTICE** Special information on operating and inspecting your motorcycle as well as maintenance and adjustment procedures.

◀ Indicates the end of an item of information.

- Instruction.

» Result of an activity.

 Reference to a page with more detailed information.

◁ Indicates the end of accessory or equipment-dependent information.

 Tightening torque.

 Technical data.

NV National-market version.

OE Optional equipment. BMW Motorrad optional equipment is already completely installed during motorcycle production.

- OA Optional accessories. BMW Motorrad optional accessories can be purchased and retrofitted at your authorized BMW Motorrad retailer.
- ABS Anti-Lock Brake System.
- ASC Automatic Stability Control.
- EWS Electronic immobilizer.
- D-ESA Electronic chassis and suspension adjustment.
- DTC Dynamic Traction Control (optional equipment only in combination with Pro riding modes).
- DWA Anti-theft alarm.
- TPC/RDC Tire Pressure Control (TPC/RDC).

## Equipment

When you ordered your BMW motorcycle, you chose various custom equipment items. These Operating Instructions describes optional equipment (OE) offered by BMW and selected optional accessories (OA). This explains why the manual may also contain descriptions of equipment which you have not ordered. Please note, too, that your motorcycle might not be exactly as illustrated in this manual on account of country-specific differences. If your motorcycle features equipment that is not described here, you can find these features described in a separate manual.

## Technical data

All dimensions, weights and performance data contained in these Operating Instructions refer to the German DIN standards and comply with their tolerance specifications.

The technical data and specifications in these Operating Instructions serve as points of reference. The vehicle-specific data may vary, for instance due to the selected optional equipment, national-market version or country-specific measuring procedures. Detailed values can be obtained from the registration documents and the signs on the vehicle or from your authorized BMW Motorrad retailer or other qualified service partner or specialist workshop. The information on the vehicle documents always takes precedence over the information in these Operating Instructions.

## Notice concerning current status

The high safety and quality standards of BMW motorcycles are maintained by consistent, ongoing development efforts embracing their design, equipment and accessories. For this reason, some aspects of your motorcycle may vary from the descriptions in these Operating Instructions. In addition, BMW Motorrad cannot guarantee the total absence of errors. We hope you will appreciate that no claims can be recognized based on the data, illustrations or descriptions in this manual.

## Additional sources of information

### BMW Motorrad retailers

Your BMW Motorrad retailer is always happy to answer any of your questions.

## Internet

The Operating Instructions for your motorcycle, the operating and installation instructions for optional accessories and general BMW Motorrad information related to the technology or other features are available at **[www.bmw-motorrad.com/service](http://www.bmw-motorrad.com/service)**.

## Certificates and operating permits

The certificates for the vehicle and the official operating permits for possible accessories are available at **[www.bmw-motorrad.com/certification](http://www.bmw-motorrad.com/certification)**.

## Data memory

### General information

Control units are installed in the vehicle. Control units process data received from vehicle sensors, self-generated data or data

exchanged between control units, for example. Some control units are required for safe vehicle operation or provide riding assistance, such as rider assistance systems. Control units also make comfort and infotainment functions possible.

Information about the stored or exchanged data can be obtained from the vehicle manufacturer, such as in the form of a separate booklet.

## Personal references

Every vehicle is marked with a unique vehicle identification number. Depending on the country, the vehicle owner can be identified using the vehicle identification number and license plate and with the help of the relevant authorities. There are also other ways to trace data obtained from the vehicle back to the rider or

vehicle owner, such as via the used ConnectedDrive Account.

## Data privacy laws

In accordance with applicable data privacy laws, vehicle users have certain rights over the vehicle manufacturer or company that collects or processes personal data.

Vehicle users have the right to obtain comprehensive information without charge from the locations that store the vehicle user's personal data.

These locations may be:

- The vehicle manufacturer
- Qualified service partners
- Specialist workshops
- Service providers

Vehicle users may request information about the type of personal data that is stored, the purpose for which the data will be used and the source of the data.

This information can only be obtained by a registered owner or a person with written proof authorizing use of the vehicle.

The right to information also includes information related to data transmitted to other companies or locations.

The vehicle manufacturer's website contains the appropriate privacy policy notices. The privacy policy notices contain information on the right to delete or correct data. The vehicle manufacturer also provides the manufacturer contact information and the contact information of the data security officer.

The vehicle owner can have a BMW Motorrad retailer or other qualified service partner or specialist workshop read out the data stored in the vehicle for a fee if required.

The vehicle data is read out via the power socket required by law

for on-board diagnosis (OBD) in the vehicle.

## Legal requirements for the disclosure of data

The vehicle manufacture is required by the law applicable in this context to provide authorities with the data stored by the manufacturer. Providing this data within the scope required is on a case-by-case basis, for instance to clarify a criminal offense.

Government agencies are authorized by the law applicable in this context to read out the data from the vehicle themselves in individual cases.

## Operating data in the vehicle

Control units process data so that the vehicle can run.

Examples of this include:

- Status messages from the vehicle and its individual components, such as wheel RPM, wheel speed and deceleration
- Environmental conditions, such as temperature
- Operating conditions of system components, such as fill levels and tire pressure
- Malfunctions and faults in key system components, such as lights and brakes
- Vehicle responses in specific riding situations, such as activation of dynamic riding systems
- Information about events causing damage to the vehicle

The data is processed only in the vehicle itself and is usually temporary. The data is not stored beyond the period in which the vehicle is operating.

Electronic components such as control units contain components for storing technical information. This may be information about the vehicle's condition, component load, events or faults stored temporarily or permanently.

This information generally documents the condition of a component, module, system or the surrounding area; for example:

The data is necessary for providing control unit functions. In addition, it is used by the vehicle manufacturer to detect and eliminate malfunctions as well as to optimize vehicle functions.

The majority of this data is temporary and is processed only within the vehicle itself. Only a small amount of event-driven data is stored in the event data recorder and fault memory.

When a vehicle is serviced, such as for repairs, servicing processes, warranty cases and quality assurance measures, this technical information can be read out from the vehicle together with the vehicle identification number.

The information can be read out by a BMW Motorrad retailer or other qualified service partner or specialist workshop. The power socket required by law for on-board diagnosis (OBD) in the vehicle is used to read out the data. The data is collected, processed and used by the respective retailer network locations. The data documents the vehicle's technical states and helps with fault finding, compliance with warranty obligations and quality improvements.

The manufacturer also has product monitoring obligations arising from product liability law. The

vehicle manufacturer requires technical data from the vehicle in order to fulfill these obligations. The data from the vehicle can also be used to verify customer warranty and guarantee claims. The fault memory and event data recorder in the vehicle can be reset by a BMW Motorrad retailer or other qualified service partner or specialist workshop as part of a repair or servicing.

## **Data input and data transfer in the vehicle**

### **General information**

Depending on the equipment, comfort settings and individualized settings in the vehicle can be saved and changed or reset at any time.

Examples of this include:

- Windshield position settings
- Chassis and suspension adjustment settings

It is possible to introduce data into the vehicle entertainment and communication system via a smartphone, for instance.

Depending on the individual equipment, this includes:

- Multimedia data, such as music for playback
- Address book data for use in conjunction with a communication system or integrated navigation system
- Entered navigation destinations
- Data about the use of Internet services. This data can be stored locally in the vehicle or is on a device connected to the vehicle, such as a smartphone, USB stick or MP3 player. If this data is saved in the vehicle, it can be deleted at any time.

This data is transmitted to third parties only upon personal request as part of the use of online

services. The data transmitted depends on the selected settings when using the services.

### **Integrating mobile end devices**

Depending on the equipment, mobile end devices connected to the vehicle, such as smartphones, are controlled using the vehicle's operating elements. This enables audio and visual output from mobile end devices through the multimedia system. At the same time, certain information is transmitted to the mobile end device. This includes for instance position data and other general vehicle data, depending on the type of integration, and makes it possible to optimize the use of selected apps, such as those for navigation or audio playback.

The way the data is processed further is determined by the

provider of the particular app used. The range of possible settings depends on the particular app and the operating system of the mobile end device.

## Services

### General information

If the vehicle has a mobile phone connection, this connection makes it possible to exchange data between the vehicle and other systems. The mobile phone connection is made possible through the vehicle's transmitter and receiver or via personally integrated mobile end devices such as smartphones. Online functions, as they are called, are used over this mobile phone connection. These include online services and apps provided by the vehicle manufacturer or other providers.

### Vehicle manufacturer services

In the case of the vehicle manufacturer's online services, the particular functions are described at the appropriate location, such as in the Operating Instructions or on manufacturer's website. The relevant legal information on data privacy is also provided there. Personal data may be used in order to provide online services. The data is exchanged over a secure connection, i.e. with the vehicle manufacturer's IT systems which are intended for this purpose. Any collection, processing and use of personal data that goes beyond the provision of services take place only as permitted by law, on the basis of a contractual agreement or as a result of consent. It is also possible to have the entire data connection activated or deactivated. This is not

the case for legally prescribed functions.

### Services of other providers

When using the online services of other providers, these services are subject to the responsibility and the data protection and usage conditions of the respective provider. The vehicle manufacturer has no control over the content exchanged via these services. Information about the type, scope and purpose of collecting and using personal data as part of third-party services can be obtained from the particular service provider.

## Overviews

Overall view, left side .....	15
General view, right side .....	17
Underneath the seat .....	18
Multifunction switch, left .....	19
Multifunction switch, right.....	20
Instrument cluster .....	21
Instrument cluster with connectiv- ity.....	22

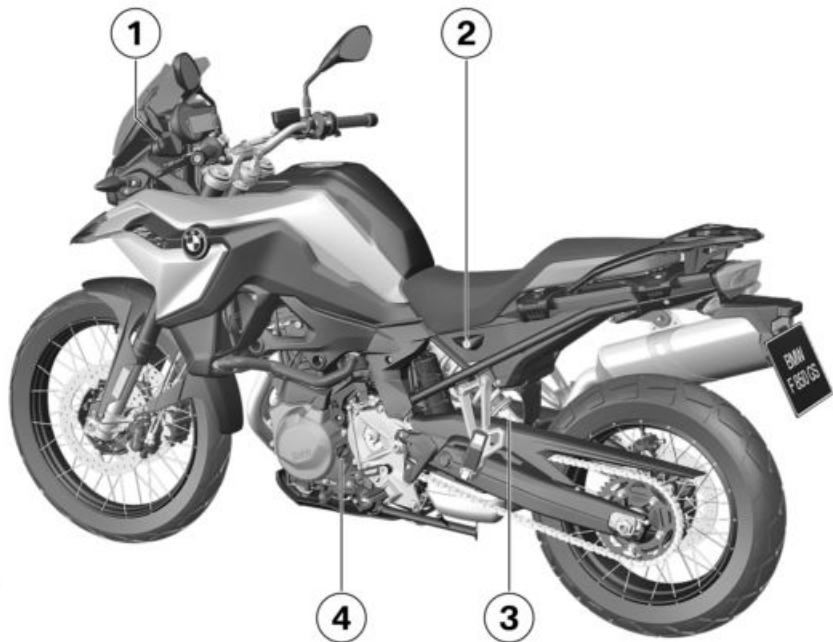



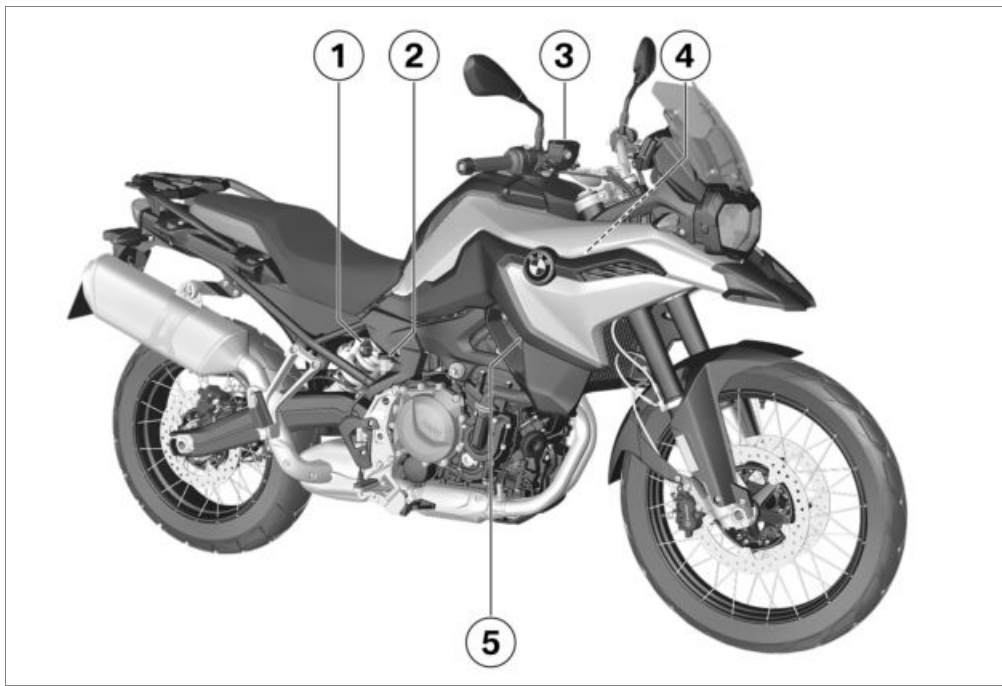

## Overall view, left side

- 1 Power socket (➡ 214)
- 2 Seat lock (➡ 106)
- 3 Adjusting the damping (➡ 141)
- 4 Oil fill location and oil dipstick (➡ 178)



## General view, right side

- 1 Spring preload setting  
( 140)
- 2 Brake-fluid reservoir, rear  
( 183)
- 3 Brake-fluid reservoir, front  
( 182)
- 4 Vehicle identification number, nameplate (on steering head)
- 5 Coolant level indicator (behind the side trim panel)  
( 186)

## Underneath the seat

- 1 Rider's Manual (US Model)  
([▶▶▶ 6](#))
- 2 Tool kit ([▶▶▶ 176](#))
- 3 Load capacity table
- 4 Battery ([▶▶▶ 205](#))
- 5 Replace main fuse  
([▶▶▶ 208](#)).
- 6 Data link connector  
([▶▶▶ 209](#))
- 7 Connector for coding plug  
– with riding modes Pro<sup>OE</sup>  
Installing encoding plug  
([▶▶▶ 98](#)).
- 8 Replace fuses ([▶▶▶ 208](#)).

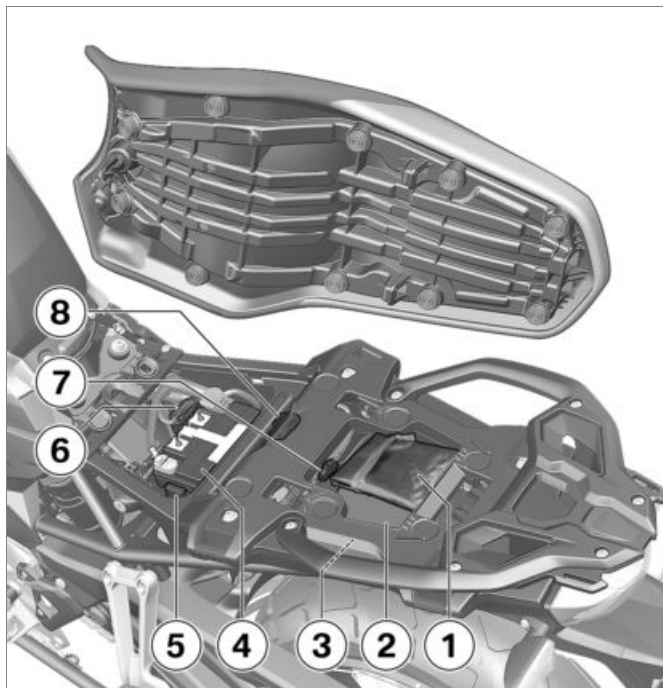

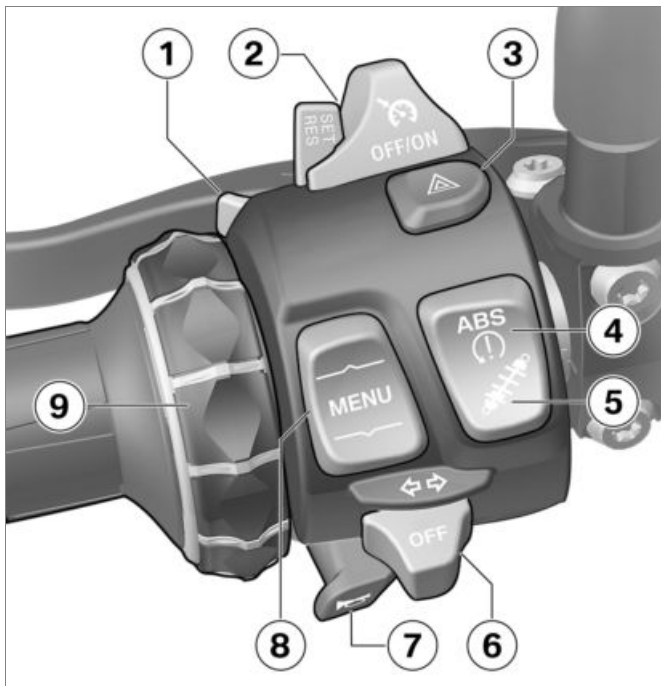

## Multifunction switch, left

- 1 High-beam headlight and headlight flasher (➡ 80)
- 2 – with cruise control<sup>OE</sup>  
Cruise-control system (➡ 103).
- 3 Hazard warning flasher (➡ 81)
- 4 ABS (➡ 89)  
ASC/DTC (➡ 91)
- 5 – with Dynamic ESA<sup>OE</sup>  
Adjustment options (➡ 93)
- 6 Turn indicators (➡ 82)
- 7 Horn
- 8 Rocker button MENU (➡ 111)
- 9 Multi-Controller  
Operating elements (➡ 111)

## Multifunction switch, right

- 1 – with heated grips<sup>OE</sup>  
Operating heated grips (➔ 105).
- 2 Riding mode (➔ 96)
- 3 Emergency on/off switch (kill switch) (➔ 79)
- 4 Starter button (➔ 147)
- 5 SOS button

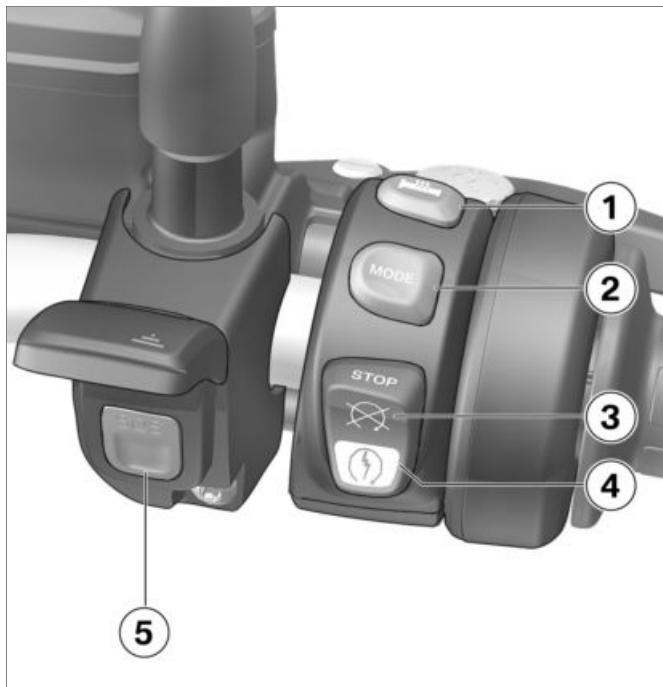

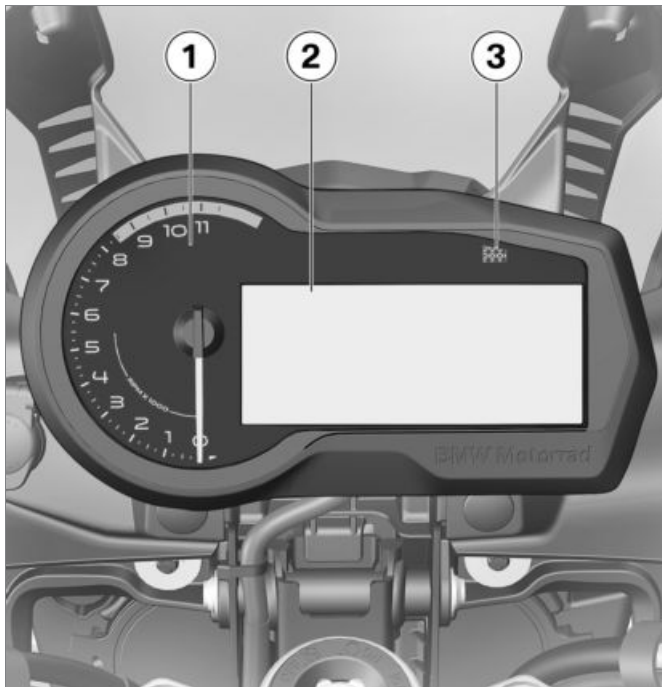

## Instrument cluster

- 1 Tachometer, indicator lights and warning lights (➡ 24)
- 2 Multifunction display (➡ 25)
- 3 Ambient brightness sensor (for adjusting brightness of the instrument lighting)  
– with anti-theft alarm system (DWA)<sup>OE</sup>  
DWA LED  
General information on DWA (➡ 132)

## Instrument cluster with connectivity

– with Connectivity<sup>OE</sup>

- 1 Indicator and warning lights with connectivity (➡ 44)
- 2 TFT display (➡ 45)  
(➡ 47)
- 3 Anti-theft alarm LED  
Alarm (➡ 134)  
– with Keyless Ride<sup>OE</sup>  
Indicator light for radio-operated key  
Ignition with Keyless Ride  
(➡ 76).
- 4 Photosensor (for adjusting brightness of instrument lighting)



## Displays

Overview of displays .....	24
Indicator lights .....	27
Overview of displays with connectivity.....	44
Indicator lights with connectivity ....	49

## Overview of displays

### Indicator and warning lights

- 1 Switching off the ABS function (➔ 89).
- 2 Turn indicator, left
- 3 Neutral position (idle)
- 4 – with cruise control<sup>OE</sup>  
Cruise-control system (➔ 103).
- 5 Fuel reserve (➔ 41)  
Fuel gauge (➔ 41)
- 6 High-beam headlight
- 7 General warning light (➔ 27)
- 8 Turn indicator, right
- 9 Photosensor  
– with anti-theft alarm system (DWA)<sup>OE</sup>  
DWA LED  
General information on DWA (➔ 132)
- 10 Auxiliary headlight
- 11 ASC/DTC (➔ 40)

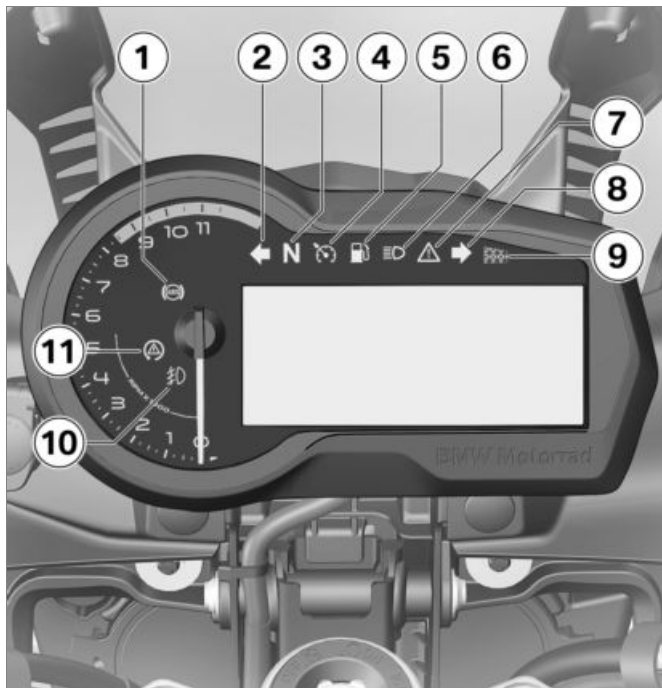

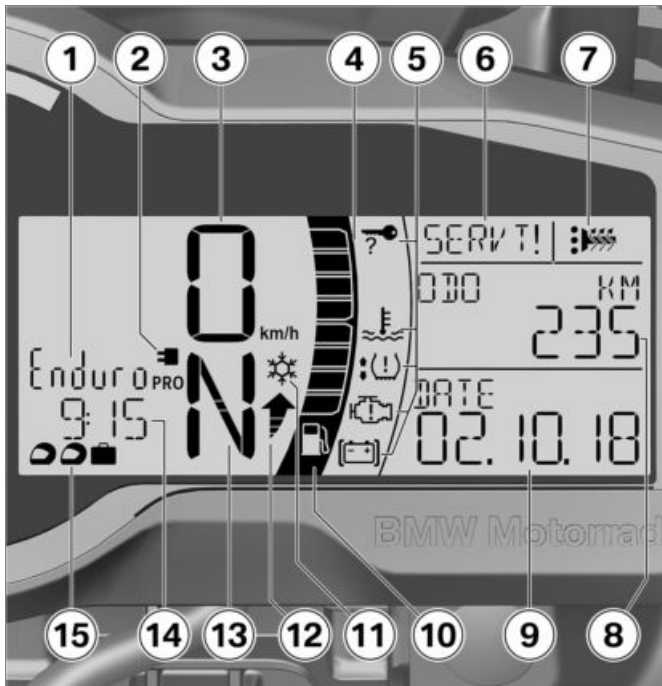

## Multifunction display

- 1 Riding modes (►► 96)
- 2 Coding plug  
– with riding modes Pro<sup>OE</sup>  
Installing encoding plug  
(►► 98).
- 3 Speedometer
- 4 Fuel gage
- 5 Warning lights (see indica-  
tor light overview)
- 6 Warning messages (see  
indicator light overview)
- 7 Heated handlebar grips  
(►► 105)
- 8 Display area, top (►► 83)
- 9 Display area, bottom  
(►► 83)
- 10 Indicator light for fuel re-  
serve (►► 41)
- 11 Outside temperature warn-  
ing (►► 32)
- 12 Upshift recommendation  
(►► 42)
- 13 Gear indicator
- 14 Time (►► 86)

**15** Dynamic ESA (▣→ 93)

## Indicator lights

### Layout

Warnings are displayed by the corresponding warning lights.















Warnings for which there is no individual warning light are signaled by the universal warning light **1** which lights up in combination with the appearance of a warning light at position **2** such as LAMPF! or a warning symbol **3** in the multifunction display. The universal warning light lights up in either yellow or red de-









pending on the urgency of the warning.

If several warnings are active, all corresponding warning lights and warning symbol are displayed; warnings are depicted in alternating fashion.

You will find an overview of the potential warnings on the following pages.

## Overview of warning indicators







Indicator and warning lights	Display text	Meaning
	 Ice crystal symbol is displayed.	Outside temperature warning (►► 32)
 General warning light lights up yellow.	 EWS warning symbol is displayed.	Electronic immobilizer is active (►► 32)
 General warning light lights up yellow.	 appears on the display.	Radio-operated key outside reception range (►► 33)
 General warning light lights up yellow.	KEYLO! appears on the display.	Replace the battery of the radio-operated key (►► 33)
 General warning light shows red.	 Symbol for vehicle voltage is displayed.	Vehicle voltage too low (►► 33)
 General warning light shows red.	 Temperature symbol is displayed.	Coolant temperature too high (►► 34)
 General warning light lights up yellow.	 Engine symbol appears on the display.	Engine in emergency-operation mode (►► 34)

Indicator and warning lights	Display text	Meaning
 General warning light lights up yellow.	LAMPF!, LAMPR!, or LAMPS! is displayed.	Bulb faulty (▶▶▶ 35)
 General warning light lights up yellow.	DWA! appears on the display.	Anti-theft alarm battery low charge (▶▶▶▶▶ 35)
 General warning light lights up yellow.	DWA! appears on the display.	Anti-theft alarm system battery discharged (▶▶▶▶▶ 36)
 General warning light lights up yellow.	 Tire symbol with one or two arrows is displayed. The critical tire pressure flashes.	Tire pressure at the limits of the permissible tolerance (▶▶▶▶▶ 37)
 General warning light flashes red.	 Tire symbol with one or two arrows is displayed. The critical tire pressure flashes.	Tire pressure is outside the approved tolerance range (▶▶▶▶▶ 37)
 General warning light lights up yellow.	 Tire symbol with one or two arrows is displayed.	Sensor faulty or system fault (▶▶▶▶▶ 38)

## Indicator and warning lights

### Display text



### Meaning

		"--" or "-- --" is displayed.	Transmission fault (▶▶▶▶ 38)
	General warning light lights up yellow.	RDC! appears on the display.	Battery of the tire pressure sensor weak (▶▶▶▶ 39)
	ABS indicator light flashes.		ABS self-diagnosis not completed (▶▶▶▶ 39)
	ABS indicator light lights up.		ABS fault (▶▶▶▶ 39)
	ABS indicator light lights up.		ABS deactivated (▶▶▶▶ 40)
	ASC/DTC indicator and warning light flashes quickly.		ASC/DTC intervention (▶▶▶▶ 40)
	ASC/DTC indicator and warning light flashes slowly.		ASC/DTC self-diagnosis not completed (▶▶▶▶ 40)

## Indicator and warning lights

## Display text

## Meaning

	ASC/DTC indicator and warning light lights up.	ASC/DTC switched off (▬▬▬▶ 41)
	ASC/DTC indicator and warning light lights up.	ASC/DTC error (▬▬▬▶ 41)
	lights up	Fuel down to reserve (▬▬▶ 41)

## Ambient temperature

Engine heat can lead to spurious readings of ambient temperature when the motorcycle is stationary. When the effects of engine heat on the monitored temperature become excessive the display responds by temporarily reverting to "--" as the display reading.

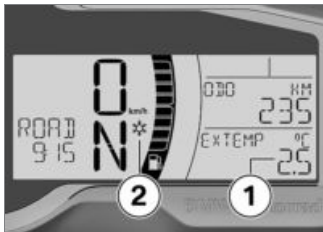

In the case of outside temperatures below 37 °F (3 °C), risk of ice formation exists. The display automatically switches from any other mode to outside temperature reading **1** when the temper-

ature drops below this threshold for the first time. The displayed value flashes.



In addition, the ice crystal symbol **2** is displayed.



### WARNING

#### Risk of black ice, even above 37 °F (3 °C)

Accident hazard

- At a low outside temperature, icy conditions must be expected on bridges and in shady road areas. ◀

#### Outside temperature warning



Ice crystal symbol is displayed.

Possible cause:

The ambient temperature measured at the vehicle is lower than 37 °F (3 °C).



### WARNING

#### Risk of black ice, even above 37 °F (3 °C)

Accident hazard

- At a low outside temperature, icy conditions must be expected on bridges and in shady road areas. ◀
- Think well ahead when driving.

#### Electronic immobilizer is active



General warning light lights up yellow.



The EWS warning symbol is displayed.

Possible cause:

The key being used is not authorized for starting, or communication between the key and engine electronics is disrupted.

- Remove other motorcycle keys from the ignition key ring.

- Use the reserve key.
- Have the defective key replaced, preferably by an authorized BMW Motorrad retailer.

## Radio-operated key outside reception range

– with Keyless Ride<sup>OE</sup>



General warning light lights up yellow.



appears on the display.

Possible cause:

Communication between the key fob transmitter and the engine electronics is disrupted.

- Check the battery in the key fob transmitter.
- with Keyless Ride<sup>OE</sup>
- Replacing the battery of the key fob transmitter (➡ 78).
- Use reserve key for further driving.

- with Keyless Ride<sup>OE</sup>
- Battery of the key fob transmitter is empty or the key fob transmitter is lost (➡ 77).
- Should the warning symbol appear while driving, keep calm. You can continue driving; the engine will not turn off.
- Have the defective key fob transmitter replaced by an authorized BMW Motorrad retailer.

## Replace the battery of the radio-operated key

– with Keyless Ride<sup>OE</sup>



General warning light lights up yellow.

KEYLO! appears on the display.  
Possible cause:

- The battery for the key fob transmitter is no longer charged to full capacity. Operation of the key fob

transmitter is only ensured for a limited time.

- Replacing the battery of the key fob transmitter (➡ 78).

## Vehicle voltage too low



General warning light shows red.



Symbol for vehicle voltage is displayed.



## WARNING

### Failure of vehicle systems

Accident hazard

- Do not continue riding.◀

The battery is not being charged. If the journey is continued, the vehicle electronics will discharge the battery.



## NOTICE

If the 12-V battery is inserted incorrectly or the terminals reversed (e.g. when jump starting),

it can blow the fuse for the alternator regulator. ◀

Possible cause:

Alternator or alternator drive faulty, battery faulty or fuse for alternator regulator blown.

- Have the malfunction corrected as soon as possible at an authorized service facility, preferably an authorized BMW Motorrad Retailer.

## Coolant temperature too high



General warning light shows red.



Temperature symbol is displayed.



### ATTENTION

## Riding with overheated engine

Engine damage

- Be sure to observe the measures listed below. ◀

Possible cause:

Coolant level is too low.

- Checking coolant level (▮▮▮▶ 186).

If coolant level is too low:

- Top up coolant (▮▮▮▶ 186).

Possible cause:

The coolant temperature is too high.

- If possible, continue driving in the part-load range to cool down the engine.
- In traffic jams, switch off the engine, but keep the ignition switched on so that the radiator fan continues to operate.
- Should the coolant temperature frequently be too high, have the fault rectified as quickly as possible by an authorized workshop, preferably an authorized BMW Motorrad retailer.

## Engine in emergency-operation mode



General warning light lights up yellow.



Engine symbol appears on the display.



### WARNING

## Unusual handling when the engine is in emergency operation

Accident hazard

- Avoid rapid acceleration and passing maneuvers. ◀

Possible cause:

The engine control unit has diagnosed a fault. In exceptional cases, the engine stops and can no longer be started. Otherwise, the engine runs in the emergency operating mode.

- Continued driving is possible, however the accustomed en-

gine performance may not be available.

- Have the malfunction corrected as soon as possible at an authorized service facility, preferably an authorized BMW Motorrad Retailer.

## Bulb faulty



General warning light lights up yellow.

LAMP! is displayed:

- LAMPF!: lowbeam headlight, high beam, parking lights, or front turn signal faulty.
- LAMPF!: additionally: daytime running lights faulty.
- LAMPRL!: brake light, rear light, rear turn signal, or number plate lighting faulty.
- LAMPSP!: several bulbs faulty.

## WARNING

### Overlooking the vehicle in traffic due to a defective light source on the vehicle

Safety risk

- Replace defective bulbs as soon as possible; it is best always to carry a complete set of spare bulbs on the motorcycle. ◀

Possible cause:

Light source faulty.

- Locate faulty light sources by means of a visual inspection.
- Replacing the LED for lowbeam headlights and high beams (▮▮▮ 200).
- Replacing the LED for the parking lights (▮▮▮ 200).
- Replacing LED for brake and rear light (▮▮▮ 200).
- Replacing front and rear turn indicator light sources (▮▮▮ 200).

– with LED additional headlight<sup>OA</sup>

- Replacing auxiliary headlights (▮▮▮ 202).

## Anti-theft alarm battery low charge

– with anti-theft alarm system (DWA)<sup>OE</sup>

DWALO! appears on the display.



## NOTICE

This fault message is only shown for a short time immediately following the Pre-Ride-Check. ◀

Possible cause:

The anti-theft alarm battery no longer has its full capacity. The operation of the anti-theft alarm system is only ensured for a limited time with the motorcycle battery disconnected.

- Contact an authorized service facility, preferably an authorized BMW Motorrad retailer.

## Anti-theft alarm system battery discharged

- with anti-theft alarm system (DWA)<sup>OE</sup>

 General warning light lights up yellow.

DWA! appears on the display.

### NOTICE

This fault message is only shown for a short time immediately following the Pre-Ride-Check. ◀

Possible cause:

The anti-theft alarm system battery is completely discharged. Operation of the anti-theft alarm system is no longer ensured when the motorcycle's battery is disconnected.

- Contact an authorized service facility, preferably an authorized BMW Motorrad retailer.

## Tire pressure

- with tire pressure monitor (TPM)<sup>OE</sup>

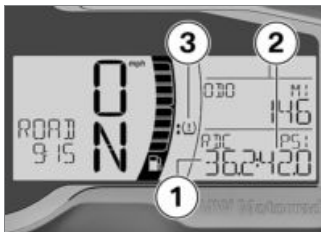

The left value **1** represents the tire pressure of the front wheel; the right value **2** the tire pressure of the rear wheel. Immediately after switching on the ignition, "--" is displayed. The transfer of the tire pressure values does not begin until a speed of 18 mph (30 km/h) is exceeded for the first

time. The displayed tire pressures refer to a tire air temperature of 68 °F (20 °C).

 If the **3** symbol appears at the same time, the display is a warning. The critical tire pressure flashes.

 If the level concerned is borderline in terms of the permissible tolerance, the general warning light lights up yellow in addition. If the monitored tire pressure is outside the specified range the general warning light will flash in red.

For more detailed information about BMW Motorrad TPC/RDC, see  171).

## Tire pressure at the limits of the permissible tolerance

– with tire pressure monitor (TPM)<sup>OE</sup>



General warning light lights up yellow.



Tire symbol with one or two arrows is displayed.

The critical tire pressure flashes.

The up arrow indicates a problem with the tire pressure on the front wheel; the down arrow indicates a problem with the tire pressure on the rear wheel.

Possible cause:

The measured tire inflation pressure is in the limit area of the permissible tolerance.

- Correct tire inflation pressure in accordance with instructions on back of cover of Rider's Manual.



## NOTICE

Before adjusting the tire pressure, check the information on temperature compensation and tire pressure adjustment in the "Technology in detail" section: ◀

» Temperature compensation (▶▶ 172)

## Tire pressure is outside the approved tolerance range

– with tire pressure monitor (TPM)<sup>OE</sup>



General warning light flashes red.



Tire symbol with one or two arrows is displayed.

The critical tire pressure flashes.



## WARNING

### Tire pressure is outside the approved tolerance range.

Risk of accident, deterioration in the handling characteristics of the vehicle.

- Adjust the driving style. ◀

The up arrow indicates a problem with the tire pressure on the front wheel; the down arrow indicates a problem with the tire pressure on the rear wheel.

Possible cause:

The measured tire inflation pressure is outside the approved tolerance range.

- Check tire for damage and suitability for continued use. If it is still possible to drive with tire:
- Correct tire inflation pressure at the next opportunity.

**NOTICE**

The TPC/RDC warning message can be deactivated in the off-road mode.◀

**NOTICE**

Before adjusting the tire pressure, check the information on temperature compensation and tire pressure adjustment in the "Technology in detail" section:◀

- » Temperature compensation (▶▶▶▶ 172)
  - Have the tire checked for damage at an authorized service facility, preferably an authorized BMW Motorrad retailer.
- If you are unsure about the tire's suitability for continued riding:
- Do not continue riding.
  - Contact roadside service.

**Sensor faulty or system fault**

– with tire pressure monitor (TPM)<sup>OE</sup>



General warning light lights up yellow.



Tire symbol with one or two arrows is displayed.

Possible cause:

Wheels without installed TPC/RDC sensors are mounted.

- Retrofit wheel set with TPM sensors.
- Possible cause:
- 1 or 2 TPM sensors have failed or there is a system fault.
- Have fault eliminated at a specialist service facility, preferably an authorized BMW Motorrad retailer.

**Transmission fault**

– with tire pressure monitor (TPM)<sup>OE</sup>

"--" or "-- --" is displayed.

Possible cause:

The vehicle has not reached the minimum speed (▶▶▶▶ 171).



TCP/RDC sensor is not active

min 19 mph (min 30 km/h)  
(The TPC/RDC sensor sends its signal to the vehicle only once the minimum speed has been exceeded.)

- Observe the TPM display at higher speed.



Only when the general warning light also lights up is this a permanent fault.

In this case:

- Have fault eliminated at a specialist service facility, preferably

an authorized BMW Motorrad retailer.

Possible cause:

The radio link to the TPM sensors is disrupted. There are radio systems in the surrounding area that are causing interference to the connection between the TPM control unit and the sensors.

- Observe the TPM display in different surroundings.

 Only when the general warning light also lights up is this a permanent fault.

In this case:

- Have fault eliminated at a specialist service facility, preferably an authorized BMW Motorrad retailer.

## Battery of the tire pressure sensor weak

– with tire pressure monitor (TPM)<sup>OE</sup>



General warning light lights up yellow.

RDC! appears on the display.



### NOTICE

This fault message is only shown for a short time immediately following the Pre-Ride-Check.◀

Possible cause:

The battery for the tire pressure sensor is no longer charged to full capacity. Operation of the tire pressure control is only ensured for a limited time.

- Contact an authorized service facility, preferably an authorized BMW Motorrad retailer.

## ABS self-diagnosis not completed



ABS indicator light flashes.

Possible cause:

The ABS is not available because the self-diagnosis has not been completed. To check the wheel sensors, the motorcycle must be driven a few yards.

- Ride off slowly. It must be noted that the ABS function is not available until the self-diagnosis has been completed.

## ABS fault



ABS indicator light lights up.

Possible cause:

– with riding modes Pro<sup>OE</sup>

The ABS Pro control unit has detected a fault. The ABS Pro function is not available. The ABS remains available, but func-

tion is limited. ABS only supports braking in straight-ahead riding.

- You may continue riding. Observe additional information on special situations which can lead to an ABS Pro faule memory entry (▮▮▮▶ 165).
- Have the malfunction corrected as soon as possible at a specialist workshop, preferably an authorized BMW Motorrad retailer.

Possible cause:

The ABS control unit has detected an error.

- It remains possible to continue riding. It must be noted that the ABS function is not available. Observe additional information on special situations which can lead to ABS fault messages (▮▮▮▶ 165).
- Have the malfunction corrected as soon as possible at an authorized service facility,

preferably an authorized BMW Motorrad Retailer.

### ABS deactivated



ABS indicator light lights up.

Possible cause:

The ABS system was deactivated by the rider.

- Switch on ABS function (▮▮▮▶ 90).

### ASC/DTC intervention



ASC/DTC indicator and warning light flashes

quickly.

ASC/DTC has detected instability at the rear wheel and responded by reducing the torque. The indicator and warning light flashes longer than the ASC/DTC intervention lasts. This feature continues to furnish the rider with visual feedback confirming that the system has initiated active closed-loop intervention even

after the critical situation has passed.

### ASC/DTC self-diagnosis not completed



ASC/DTC indicator and warning light flashes slowly.

Possible cause:



ASC/DTC self-diagnosis not completed

ASC/DTC is not available, as the self-diagnosis routine was not completed. (The motorcycle must reach a specified minimum speed before the system can check operation of the wheel speed sensors: min 3 mph (min 5 km/h))

- Ride off slowly. It must be noted that the ASC/DTC function is not available until the self-diagnosis has been completed.

## ASC/DTC switched off



ASC/DTC indicator and warning light lights up.

Possible cause:

The ASC/DTC system was switched off by the rider.

- Switching on the ASC/DTC function (►►► 92).

## ASC/DTC error



ASC/DTC indicator and warning light lights up.

Possible cause:

The ASC/DTC control unit has detected a fault. The ASC/DTC function is not available.

- You may continue riding. It must be noted that the ASC/DTC function is not available. You should also take account of the additional information on situations that can lead to an ASC/DTC fault (►►► 167).
- Have the malfunction corrected as soon as possible at a spe-

cialist workshop, preferably an authorized BMW Motorrad retailer.

## Fuel down to reserve



Fuel-reserve warning light lights up.



### WARNING

#### Rough engine running or switching off of the engine due to a fuel shortage

Accident hazard, damage to catalytic converter

- Do not drive to the extent that the fuel tank is completely empty. ◀

Possible cause:

At the most, the fuel tank still contains the reserve fuel quantity.



Reserve fuel quantity

Approx. 3.7 quarts (Approx. 3.5 l)

- Refueling procedure (►►► 157).

## Fuel reserve

The fuel quantity in the fuel tank when the fuel warning light turns on depends on the driving dynamics. The more the fuel in the tank moves (due to frequently changing inclined positions, frequent braking and accelerating), the more difficult it is to determine the fuel reserve. For this reason, it is not possible to specify the exact fuel reserve quantity.



After the fuel warning light comes on, the range is automatically displayed.

The distance that can still be traveled with the fuel reserve is dependent on the riding style

(consumption) and the fuel quantity still available when the warning light comes on (see explanation above).

The distance recorder for the fuel reserve is reset once the fuel quantity after refueling is greater than the fuel reserve.

### Service display



If the service is due within a month, the **SERV T! 1** display and the service date **2** are shown. This is displayed for a short time following the Pre-Ride-Check.



If the service is due within 700 miles, the **SERV D! 3** display and the remaining distance **4** are displayed and counted down in steps of 100 miles. This is displayed for a short time following the Pre-Ride-Check.



If service is overdue, the due date or the odometer reading at which service was due is accompanied by the 'General' warning light showing yellow. The **SERV D!** or **SERV T!** displays are permanently shown.



### NOTICE

If the service display appears more than a month before the service date, the current day's date must be reset in the instrument cluster. This situation can occur if the battery was disconnected.◀

### Upshift recommendation

The upshift recommendation must be switched on in the display settings (▶▶ 85).



Upshift recommendation **1** signals the economically best point in time for upshifting.

## Overview of displays with connectivity

### Indicator and warning lights with connectivity

– with Connectivity<sup>OE</sup>

- 1 Turn indicator, left  
Operating turn signals (▶▶▶ 82).
- 2 High-beam headlight (▶▶▶ 80)
- 3 General warning light (▶▶▶ 49)
- 4 Turn indicator, right
- 5 ASC/DTC (▶▶▶ 68)
- 6 ABS (▶▶▶ 89)
- 7 Auxiliary headlight

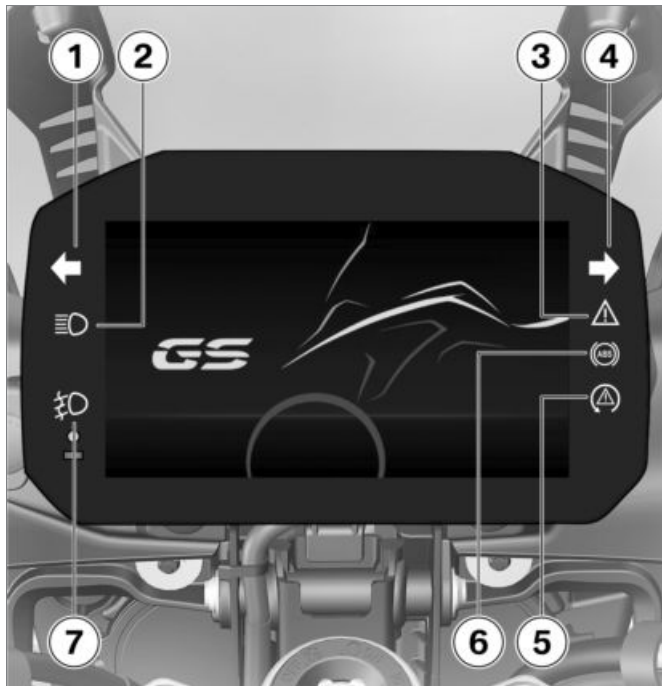

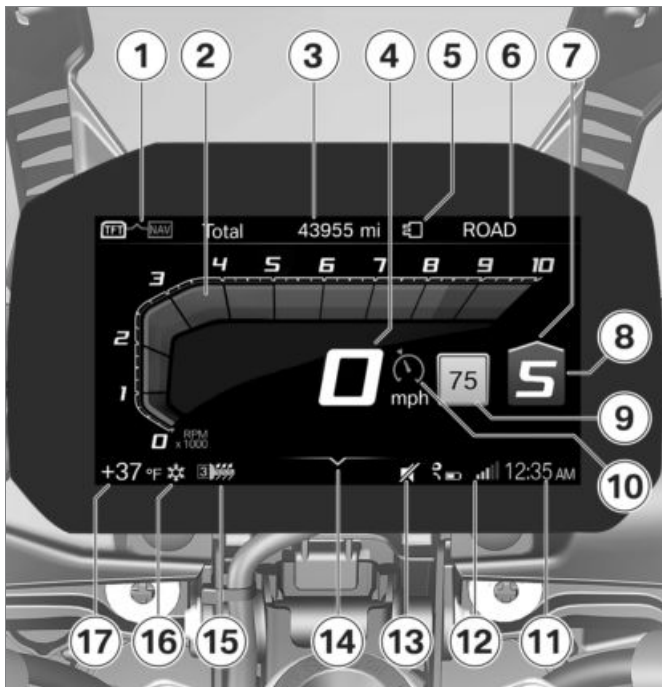





## TFT display in Pure Ride view

– with Connectivity<sup>OE</sup>

- 1 Operating focus change (➡ 115)
- 2 Tachometer (➡ 117)
- 3 Driver info. status line (➡ 116)
- 4 Speedometer
- 5 Coding plug  
– with riding modes Pro<sup>OE</sup>  
Installing encoding plug (➡ 98).
- 6 Riding mode (➡ 96)
- 7 Upshift recommendation (➡ 118)
- 8 Gear indicator, shows "N" in neutral (idling).
- 9 Speed Limit Info (➡ 117)
- 10 – with cruise control<sup>OE</sup>  
Cruise-control system (➡ 103).
- 11 Clock (➡ 119)

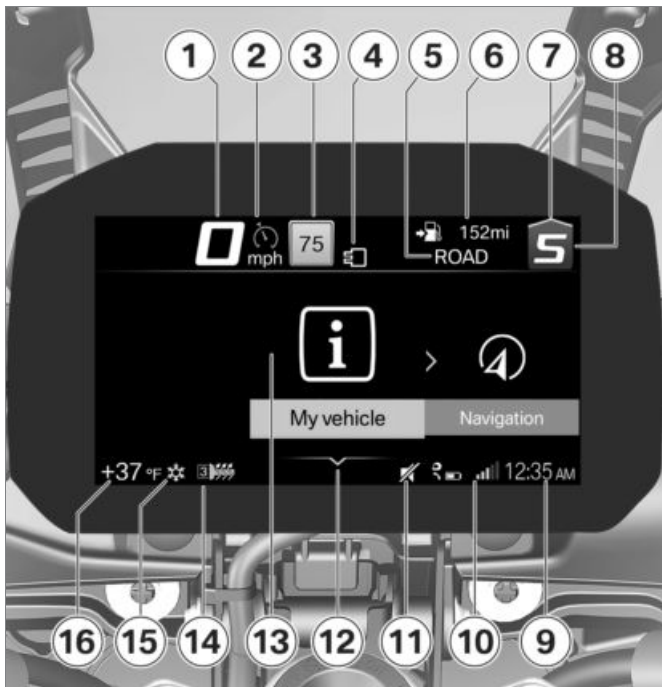

- 12** Connection status  
( 121)
- 13** Mute ( 118)
- 14** Operating assistance
- 15** Heated grip settings  
( 105)
- 16** Outside temperature warn-  
ing ( 58)
- 17** Outside temperature



## TFT display in the View menu

– with Connectivity<sup>OE</sup>

- 1 Speedometer
- 2 – with cruise control<sup>OE</sup>  
Cruise-control system (➡ 103).
- 3 Speed Limit Info (➡ 117)
- 4 Coding plug  
– with riding modes Pro<sup>OE</sup>  
Installing encoding plug (➡ 98).
- 5 Riding mode (➡ 96)
- 6 Driver info. status line (➡ 116)
- 7 Upshift recommendation (➡ 118)
- 8 Gear indicator, shows "N" in neutral (idling).
- 9 Clock
- 10 Connection status
- 11 Mute (➡ 118)
- 12 Operating assistance
- 13 Menu area

- 14** Heated grip settings  
( 105)
- 15** Outside temperature warning ( 58)
- 16** Outside temperature

## Indicator lights with connectivity

### Layout

Warnings are displayed by the corresponding warning lights. Warnings are indicated by the general warning light in conjunction with a dialog in the TFT display. The general warning light lights up in either yellow or red depending on the urgency of the warning.



The general warning light lights up for whichever warning is most urgent at the current time.

You will find an overview of the potential warnings on the following pages.



### Check Control display

The messages in the display are shown differently in the display. Different colors and characters are used depending on the priority:

- Green CHECK OK **1**: no message, values optimal.
- White circle with small "i" **2**: information.
- Yellow warning triangle **3**: warning message, value not optimal.
- Red warning triangle **3**: warning message, value critical

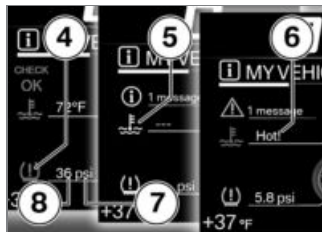

### Value display

The symbols **4** differ in their display. Different colors are used depending on the assessment of value. Instead of numerical values **8** with units **7**, texts **6** are also displayed:

#### Color of the symbol

- Green: (OK) current value is optimal.
- Blue: (Cold!) current temperature is too low.
- Yellow: (Low! /High!) current value is too low or too high.
- Red: (Hot! /High!) current temperature or value is too high.

- White: (---) there is no valid value. Instead of the value, dashes **5** are displayed.

## NOTICE

The evaluation of the individual values is possible in part only after a certain riding duration or speed. If a measured value cannot yet be displayed due to unfulfilled measurement conditions, dashes are displayed instead as placeholders. As long as no valid measured value is available, no evaluation is carried out in the form of a colored symbol.◀













### Check Control dialog

Messages are output as Check Control dialog **1**.

- If several Check Control messages of the same priority are present, the messages change in the order in which they occur, until they are acknowledged.
- If the symbol **2** is active, this can be acknowledged by tilting the Multi-Controller to the left.
- Check Control messages are dynamically attached as additional tabs to the pages in the menu *My vehicle* (▮▮▮ 113). The message can be called up

again as long as the error persists.













## Overview of warning indicators

Indicator and warning lights	Display text	Meaning
	 Ice crystal symbol is displayed.	Outside temperature warning (►►► 58)
 General warning light lights up yellow.	 Key remote not in range.	Radio-operated key outside reception range (►►► 58)
 General warning light lights up yellow.	 Key remote battery at 50%.	Replace the battery of the radio-operated key (►►► 59)
	 Key remote battery low.	
 General warning light lights up yellow.	 Displayed in yellow.	Vehicle voltage too low (►►► 59)
	 Vehicle voltage low.	
 General warning light shows red.	 Displayed in red.	Vehicle voltage critical (►►► 59)

## Indicator and warning lights

## Display text











## Meaning

		Vehicle voltage critical!	Vehicle voltage critical (➡ 59)
	General warning light lights up yellow.		The faulty light source is displayed. Bulb faulty (➡ 60)
		Anti-theft alarm batt. capacity low.	Anti-theft alarm battery low charge (➡ 61)
	General warning light lights up yellow.		Anti-theft alarm battery discharged (➡ 61)
	General warning light shows red.		Coolant temperature too high!
	General warning light lights up yellow.		No communication with engine control. Engine control failure (➡ 62)
	General warning light lights up yellow.		Fault in the engine control. Engine in emergency-operation mode (➡ 62)

## Indicator and warning lights

## Display text













## Meaning

 General warning light flashes yellow.	 Serious fault in engine control.	Serious fault in the engine control (→ 63)
 General warning light lights up yellow.	 Displayed in yellow.	Tire pressure at the limits of the permissible tolerance. (→ 63)
	 Tire pressure not at setpoint.	
 General warning light flashes red.	 Displayed in red.	Tire pressure is outside the approved tolerance range (→ 64)
	 Tire pressure not at setpoint.	
	 Tire press. monitor. Loss of pressure.	
	 "----"	Transmission fault (→ 65)

## Indicator and warning lights

## Display text











## Meaning

	General warning light lights up yellow.		"---"	Sensor faulty or system fault (→ 66)
	General warning light lights up yellow.		TPM sensors battery low.	Battery of the tire pressure sensor weak (→ 66)
			Fall sensor faulty.	Fall sensor defective (→ 66)
			Side stand monitoring faulty.	Side stand monitoring faulty (→ 66)
	ABS indicator light flashes.			ABS self-diagnosis not completed (→ 39)
	ABS indicator light lights up.		Off!	ABS deactivated (→ 67)
			ABS deactivated.	
	ABS indicator light lights up.		Limited ABS availability!	ABS fault (→ 67)

## Indicator and warning lights

## Display text









## Meaning

	ABS indicator light lights up.		ABS failure!	ABS failure (→ 67)
	ABS indicator light lights up.		ABS Pro failure!	ABS Pro failure (→ 68)
	ASC/DTC indicator and warning light flashes quickly.			ASC/DTC intervention (→ 68)
	ASC/DTC indicator and warning light flashes slowly.			ASC/DTC self-diagnosis routine not completed (→ 68)
	ASC/DTC indicator and warning light lights up.		Off!	ASC/DTC switched off (→ 69)
			Traction control deactivated.	
	ASC/DTC indicator and warning light lights up.		Traction control limited.	Limited ASC/DTC availability (→ 69)

## Indicator and warning lights

## Display text



## Meaning

	ASC/DTC indicator and warning light lights up.	 Traction control failure!	ASC/DTC error (→ 69)
	General warning light lights up yellow.	 Spring strut adjustment faulty!	D-ESA fault (→ 70)
		 Fuel reserve is being used up. Drive to the nearest filling station.	Fuel down to reserve (→ 70)
		 Gear indicator flashes.	Gear not trained (→ 71)
	Left turn signal indicator light flashes green.		Hazard warning lights system switched on (→ 71)
	Right turn signal indicator light flashes green.		
		 Displayed in white.	Service due (→ 72)

## Indicator and warning lights

## Display text

## Meaning

Indicator and warning lights	Display text	Meaning
	Service due!	Service due (▣▣▣→ 72)
 General warning light lights up yellow.	 Displayed in yellow.	Service date missed (▣▣▣→ 72)
	Service overdue!	

## Outside temperature

The outside temperature is displayed in the status line of the TFT display.

Engine heat can lead to spurious readings of ambient temperature when the motorcycle is stationary. If the effect of the engine heat becomes excessive, dashes are temporarily displayed instead of the value.



If the outside temperature falls below the following limit value, there is a risk of black ice formation.



Limit value for outside temperature

Approx. 37 °F (Approx. 3 °C)

When this temperature is fallen short of for the first time, the outside temperature display flashes together with the ice crystal sym-

bol in the status line of the TFT display.

## Outside temperature warning



Ice crystal symbol is displayed.

Possible cause:

The ambient temperature measured at the vehicle is lower than 37 °F (3 °C).



### WARNING

#### Risk of black ice, even above 37 °F (3 °C)

Accident hazard

- At a low outside temperature, icy conditions must be expected on bridges and in shady road areas. ◀
- Think well ahead when driving.

## Radio-operated key outside reception range

– with Keyless Ride<sup>OE</sup>



General warning light lights up yellow.



Key remote not in range. It is not possible to turn on the ignition again.

Possible cause:

Communication between the key fob transmitter and the engine electronics is disrupted.

- Check the battery in the key fob transmitter.
- with Keyless Ride<sup>OE</sup>
- Replacing the battery of the key fob transmitter (▶▶ 78).
- Use reserve key for further driving.
- with Keyless Ride<sup>OE</sup>
- Battery of the key fob transmitter is empty or the key fob transmitter is lost (▶▶ 77).

- Should the Check Control dialog appear while riding, keep calm. You can continue driving; the engine will not turn off.
- Have the defective key fob transmitter replaced by an authorized BMW Motorrad retailer.

## Replace the battery of the radio-operated key

– with Keyless Ride<sup>OE</sup>



General warning light lights up yellow.



Key remote battery at 50%. No functional limitation.



Key remote battery low. Limited central locking function. Change battery.

Possible cause:

- The battery for the key fob transmitter is no longer charged to full capacity. Operation of the key fob transmitter is only ensured for a limited time.
- Replacing the battery of the key fob transmitter (►► 78).

## Vehicle voltage too low



General warning light lights up yellow.



Displayed in yellow.



Vehicle voltage low. Switch off unneeded consumers.



**WARNING**

## Failure of vehicle systems

Accident hazard

- Do not continue riding.◀

The battery is not being charged. If the journey is continued, the vehicle electronics will discharge the battery.



**NOTICE**

If the 12-V battery is inserted incorrectly or the terminals reversed (e.g. when jump starting), it can blow the fuse for the alternator regulator.◀

Possible cause:

Alternator or alternator drive faulty, battery faulty or fuse for alternator regulator blown.

- Have the malfunction corrected as soon as possible at an authorized service facility, preferably an authorized BMW Motorrad Retailer.

## Vehicle voltage critical



General warning light shows red.

 Displayed in red.

 Vehicle voltage critical! Consumers were switched off Check battery condition.

### WARNING

#### Failure of vehicle systems

Accident hazard

- Do not continue riding. ◀

The battery is not being charged. If the journey is continued, the vehicle electronics will discharge the battery.

### NOTICE

If the 12-V battery is inserted incorrectly or the terminals reversed (e.g. when jump starting), it can blow the fuse for the alternator regulator. ◀

Possible cause:

Alternator or alternator drive faulty, battery faulty or fuse for alternator regulator blown.

- Have the malfunction corrected as soon as possible at an authorized service facility, preferably an authorized BMW Motorrad Retailer.

#### Bulb faulty

 General warning light lights up yellow.

 The faulty light source is displayed:

 High beam faulty!

 Front left turn indicator faulty! or Front right turn indicator faulty!

 Low beam faulty!

 Front parking lamp faulty!

 Daytime riding light faulty!

 Tail light faulty!

 Brake light faulty!

 Rear left turn indicator faulty! or Rear right turn indicator faulty!

 License plate light faulty!

– Have checked by a specialist workshop.

## **WARNING**

### **Overlooking the vehicle in traffic due to a defective light source on the vehicle**

Safety risk

- Replace defective bulbs as soon as possible; it is best always to carry a complete set of spare bulbs on the motorcycle. ◀

Possible cause:

Light source faulty.

- Locate faulty light sources by means of a visual inspection.
- Replacing the LED for lowbeam headlights and high beams (➡ 200).
- Replacing the LED for the parking lights (➡ 200).
- Replacing LED for brake and rear light (➡ 200).
- Replacing front and rear turn indicator light sources (➡ 200).

- with LED additional headlight<sup>OA</sup>
- Replacing auxiliary headlights (➡ 202).

### **Anti-theft alarm battery low charge**

- with anti-theft alarm system (DWA)<sup>OE</sup>

 Anti-theft alarm batt. capacity low. No limitations. Arrange an appointment at a specialist workshop.

## **NOTICE**

This fault message is only shown for a short time immediately following the Pre-Ride-Check. ◀

Possible cause:

The anti-theft alarm battery no longer has its full capacity. The operation of the anti-theft alarm system is only ensured for a lim-

ited time with the motorcycle battery disconnected.

- Contact an authorized service facility, preferably an authorized BMW Motorrad retailer.

### **Anti-theft alarm system battery discharged**

- with anti-theft alarm system (DWA)<sup>OE</sup>

 General warning light lights up yellow.

 Anti-theft alarm battery discharged. No independent alarm. Arrange an appointment at a specialist workshop.

## **NOTICE**

This fault message is only shown for a short time immediately following the Pre-Ride-Check. ◀

Possible cause:

The anti-theft alarm system battery is completely discharged. Operation of the anti-theft alarm system is no longer ensured when the motorcycle's battery is disconnected.

- Contact an authorized service facility, preferably an authorized BMW Motorrad retailer.

### Coolant temperature too high



General warning light shows red.



Coolant temperature too high! Check coolant level. Carry on at moderate pace to cool.



### ATTENTION

#### Riding with overheated engine

Engine damage

- Be sure to observe the measures listed below. ◀

Possible cause:

Coolant level is too low.

- Checking coolant level (▶▶ 186).

If coolant level is too low:

- Top up coolant (▶▶ 186).

Possible cause:

The coolant temperature is too high.

- If possible, continue driving in the part-load range to cool down the engine.
- In traffic jams, switch off the engine, but keep the ignition switched on so that the radiator fan continues to operate.
- Should the coolant temperature frequently be too high, have the fault rectified as quickly as possible by an authorized workshop, preferably an authorized BMW Motorrad retailer.

### Engine control failure



General warning light lights up yellow.



No communication with engine control. Multiple sys. affected. Ride carefully to the next specialist workshop.

### Engine in emergency-operation mode



General warning light lights up yellow.



Fault in the engine control. Onward journey possible. Ride carefully to next specialist workshop.

## **WARNING**

### **Unusual handling when the engine is in emergency operation**

Accident hazard

- Avoid rapid acceleration and passing maneuvers. ◀

Possible cause:

The engine control unit has diagnosed a fault. In exceptional cases, the engine stops and can no longer be started. Otherwise, the engine runs in the emergency operating mode.

- Continued driving is possible, however the accustomed engine performance may not be available.
- Have the malfunction corrected as soon as possible at an authorized service facility, preferably an authorized BMW Motorrad Retailer.

### **Serious fault in the engine control**



General warning light flashes yellow.



Serious fault in engine control. Onward journey possible. Damage possible. Have checked by a workshop.

## **WARNING**

### **Damage to engine during emergency operation**

Accident hazard

- Drive slowly and avoid rapid acceleration and passing maneuvers.
- If possible, have the vehicle picked up and the fault eliminated at a specialist workshop, preferably an authorized BMW Motorrad retailer. ◀

Possible cause:

The engine control unit has diagnosed a fault, which can lead to a severe secondary fault. The engine is in the emergency-operation mode.

- Avoid high load and engine speed ranges if possible.
  - Have the malfunction corrected as soon as possible at an authorized service facility, preferably an authorized BMW Motorrad Retailer.
- » Continued driving is possible, however it is not recommended.

### **Tire pressure at the limits of the permissible tolerance**

– with tire pressure monitor (TPM)<sup>OE</sup>



General warning light lights up yellow.



Displayed in yellow.



Tire pressure not at setpoint. Check tire pressure.

Possible cause:

The measured tire pressure is within the limit range of the permissible tolerance.

- Correct tire pressure.
- Before adjusting the tire pressure, check the information on temperature compensation and tire pressure adjustment in the "Technology in detail" section:
  - » Temperature compensation (▣▣▣▶ 172)
  - » Tire pressure adjustment (▣▣▣▶ 172)
  - » The target tire pressures can be found in the following locations:
    - On the back cover of the rider's manual

- Instrument cluster in the TIRE PRESSURE view
- Sign underneath the seat

### Tire pressure is outside the approved tolerance range

- with tire pressure monitor (TPM)<sup>OE</sup>



General warning light flashes red.



Displayed in red.



Tire pressure not at setpoint. Stop immediately! Check tire pressure.



Tire press. monitor. Loss of pressure. Stop immediately! Check tire pressure.



## WARNING

### Tire pressure is outside the approved tolerance range.

Risk of accident, deterioration in the handling characteristics of the vehicle.

- Adjust the driving style.◀

Possible cause:

The measured tire pressure is outside of the permissible tolerance.

- Check the tires for damage and driveability.

Can the tire still be driven on:

- Correct the tire pressure at the next opportunity.
- Before adjusting the tire pressure, check the information on temperature compensation and tire pressure adjustment in the "Technology in detail" section:
  - » Temperature compensation (▣▣▣▶ 172)

- » Tire pressure adjustment (➡ 172)
- » The target tire pressures can be found in the following locations:
  - On the back cover of the rider's manual
  - Instrument cluster in the **TIRE PRESSURE** view
  - Sign underneath the seat
- Have the tires checked by a specialist workshop for damage, preferably an authorized BMW Motorrad retailer.



## NOTICE

The TPC/RDC warning message can be deactivated in the off-road mode. ◀

In the event of uncertainty about the driveability of the tire:

- Do not continue riding.
- Inform roadside assistance.

## Transmission fault

- with tire pressure monitor (TPM)<sup>OE</sup>



"----"

Possible cause:

The vehicle has not reached the minimum speed (➡ 171).



TPC/RDC sensor is not active

min 19 mph (min 30 km/h)  
(The TPC/RDC sensor sends its signal to the vehicle only once the minimum speed has been exceeded.)

- Observe the TPM display at higher speed.



Only when the general warning light also lights up is this a permanent fault.

In this case:

- Have fault eliminated at a specialist service facility, preferably

an authorized BMW Motorrad retailer.

Possible cause:

The radio link to the TPM sensors is disrupted. There are radio systems in the surrounding area that are causing interference to the connection between the TPM control unit and the sensors.

- Observe the TPM display in different surroundings.



Only when the general warning light also lights up is this a permanent fault.

In this case:

- Have fault eliminated at a specialist service facility, preferably an authorized BMW Motorrad retailer.

## Sensor faulty or system fault

– with tire pressure monitor (TPM)<sup>OE</sup>



General warning light lights up yellow.



"----"

Possible cause:

Wheels without installed TPC/RDC sensors are mounted.

- Retrofit wheel set with TPM sensors.

Possible cause:

1 or 2 TPM sensors have failed or there is a system fault.

- Have fault eliminated at a specialist service facility, preferably an authorized BMW Motorrad retailer.

## Battery of the tire pressure sensor weak

– with tire pressure monitor (TPM)<sup>OE</sup>



General warning light lights up yellow.



TPM sensors battery low. Function limited. Have checked by a specialist workshop.



### NOTICE

This fault message is only shown for a short time immediately following the Pre-Ride-Check. ◀

Possible cause:

The battery for the tire pressure sensor is no longer charged to full capacity. Operation of the tire pressure control is only ensured for a limited time.

- Contact an authorized service facility, preferably an authorized BMW Motorrad retailer.

## Fall sensor defective



Fall sensor faulty. Have checked by a specialist workshop.

Possible cause:

The fall sensor is not functioning.

- Contact an authorized service facility, preferably an authorized BMW Motorrad retailer.

## Side stand monitoring faulty



Side stand monitoring faulty. Onward journey possible. Stop engine when stationary! Have checked by workshop.

Possible cause:

The side-stand switch or its wiring is damaged.

- Contact an authorized service facility, preferably an authorized BMW Motorrad retailer.

## ABS self-diagnosis not completed



ABS indicator light flashes.

Possible cause:

The ABS is not available because the self-diagnosis has not been completed. To check the wheel sensors, the motorcycle must be driven a few yards.

- Ride off slowly. It must be noted that the ABS function is not available until the self-diagnosis has been completed.

## ABS deactivated



ABS indicator light lights up.



Off!



ABS deactivated.

Possible cause:

The ABS system was deactivated by the rider.

- Switch on ABS function (▣▣▣ 90).

## ABS fault



ABS indicator light lights up.



Limited ABS availability! Onward journey possible. Ride carefully to next specialist workshop.

Possible cause:

The ABS control unit has detected an error. The ABS function is limited.

- It remains possible to continue riding. Observe additional information on special situations which can lead to ABS fault messages (▣▣▣ 165).
- Have the malfunction corrected as soon as possible at an authorized service facility, preferably an authorized BMW Motorrad Retailer.

## ABS failure



ABS indicator light lights up.



ABS failure! Onward journey possible. Ride carefully to next specialist workshop.

Possible cause:

The ABS control unit has detected an error.

- It remains possible to continue riding. It must be noted that the ABS function is not available. Observe additional information on special situations which can lead to ABS fault messages (▣▣▣▣ 165).
- Have the malfunction corrected as soon as possible at an authorized service facility, preferably an authorized BMW Motorrad Retailer.

### ABS Pro failure

– with riding modes Pro<sup>OE</sup>



ABS indicator light lights up.



ABS Pro failure! Onward journey possible. Ride carefully to next specialist workshop.

Possible cause:

The ABS Pro control unit has detected a fault. The ABS Pro function is not available. The ABS remains available, but function is limited. ABS only supports braking in straight-ahead riding.

- You may continue riding. Observe additional information on special situations which can lead to an ABS Pro fault memory entry (▣▣▣▣ 165).
- Have the malfunction corrected as soon as possible at a specialist workshop, preferably an authorized BMW Motorrad retailer.

### ASC/DTC intervention



ASC/DTC indicator and warning light flashes quickly.

ASC/DTC has detected instability at the rear wheel and responded by reducing the torque. The indicator and warning light flashes

longer than the ASC/DTC intervention lasts. This feature continues to furnish the rider with visual feedback confirming that the system has initiated active closed-loop intervention even after the critical situation has passed.

### ASC/DTC self-diagnosis routine not completed



ASC/DTC indicator and warning light flashes slowly.

Possible cause:



ASC/DTC self-diagnosis not completed

ASC/DTC is not available, as the self-diagnosis routine was not completed. (The motorcycle must reach a specified minimum speed before the system can check operation of the wheel speed sensors: min 3 mph (min 5 km/h))

- Ride off slowly. The ASC/DTC indicator and warning light must go out after a few meters.

If the ASC/DTC indicator and warning light continues flashing:

- Contact a specialist workshop, preferably an authorized BMW Motorrad retailer.

### ASC/DTC switched off

 ASC/DTC indicator and warning light lights up.

 Off!

 Traction control deactivated.

Possible cause:

The ASC/DTC system was switched off by the rider.

- Switching on the ASC/DTC function (➡ 92).

### Limited ASC/DTC availability

 ASC/DTC indicator and warning light lights up.

 Traction control limited. Onward journey possible. Ride carefully to next specialist workshop.

Possible cause:

The ASC/DTC control unit has detected a fault.

### ATTENTION

#### Damage to components

Damage to sensors, for example, with the resultant malfunctions

- Do not carry along any objects under the rider's or passenger's seat.
- Secure vehicle tools. ◀
- Do not damage the rotational speed sensor.

- It must be noted that only limited ASC/DTC function is available.
- It remains possible to continue riding. Observe additional information on situations that can lead to a ASC/DTC fault (➡ 167).
- Have the malfunction corrected as soon as possible at an authorized specialist workshop, preferably an authorized BMW Motorrad retailer.

### ASC/DTC error

 ASC/DTC indicator and warning light lights up.

 Traction control failure! Onward journey possible. Ride carefully to next specialist workshop.

Possible cause:

The ASC/DTC control unit has detected a fault.



## ATTENTION

### Damage to components

Damage to sensors, for example, with the resultant malfunctions

- Do not carry along any objects under the rider's or passenger's seat.
- Secure vehicle tools. ◀
- Do not damage the rotational speed sensor.
- It must be noted that the ASC/DTC function is not available at all or is restricted.
- It remains possible to continue riding. Observe additional information on situations that can lead to a ASC/DTC fault (▮▶ 167).
- Have the malfunction corrected as soon as possible at an authorized specialist workshop,

preferably an authorized BMW Motorrad retailer.

### D-ESA fault



General warning light lights up yellow.



Spring strut adjustment faulty! Onward journey possible. Ride carefully to next specialist workshop.

Possible cause:

The D-ESA control unit has detected a fault. Damping action and/or the spring adjustment may be the cause. In this state, the motorcycle is probably heavily damped and is uncomfortable to drive, particularly on poor roadways. Alternatively, the spring preload may be set incorrectly.

- Have the malfunction corrected as soon as possible at an authorized service facility,

preferably an authorized BMW Motorrad Retailer.

### Fuel down to reserve



Fuel reserve is being used up. Drive to the nearest filling station.



## WARNING

### Rough engine running or switching off of the engine due to a fuel shortage

Accident hazard, damage to catalytic converter

- Do not drive to the extent that the fuel tank is completely empty. ◀

Possible cause:

At the most, the fuel tank still contains the reserve fuel quantity.



Reserve fuel quantity

Approx. 3.7 quarts (Approx. 3.5 l)

- Refueling procedure (►► 157).

## Gear not trained

– with Gearshift Assistant Pro<sup>OE</sup>

**N** The gear indicator flashes. The gearshift assistant Pro has no function.

Possible cause:

– with Gearshift Assistant Pro<sup>OE</sup>

The transmission sensor has not been completely trained.

- Engage idle position **N** and allow the engine to run for at least 10 seconds while parked to train the idle position.
- Shift all gears with clutch control and drive for at least 10 seconds in each engaged gear.
- » The gear indicator stops flashing when the transmission

sensor has been successfully trained.

- If the transmission sensor is completely trained, the gearshift assistant Pro functions as described (►► 172).
- If the training procedure is unsuccessful, have the fault corrected at a specialist workshop, preferably an authorized BMW Motorrad retailer.

## Hazard warning lights system switched on



Left turn signal indicator light flashes green.



Right turn signal indicator light flashes green.

Possible cause:

The hazard warning lights system was switched on by the rider.

- Operating hazard warning flashers (►► 81).

## Service display



If service is overdue, the due date or the odometer reading at which service was due is accompanied by the 'General' warning light showing yellow.

If service is overdue, a yellow CC message is displayed. The displays for service, service date, and remaining distance are also highlighted with exclamation marks in the menu windows MY VEHICLE and SERVICE REQUIREMENTS.



## NOTICE

If the service display appears more than a month before the service date, the current day's date must be reset in the instrument cluster. This situation can occur if the battery was disconnected.◀

## Service due



Displayed in white.

Service due! Have a service performed at a specialist workshop.

Possible cause:

Service is due because of the driving performance or the date.

- Have service performed regularly by a specialist workshop, preferably an authorized BMW Motorrad retailer.
- » The operating and road safety of the vehicle remains unchanged.
- » The best-possible value retention of the vehicle is ensured.

## Service date missed



General warning light lights up yellow.



Displayed in yellow.

Service overdue! Have a service performed at a specialist workshop.

Possible cause:

Service is overdue because of the riding performance or the date.

- Have service performed regularly by a specialist workshop, preferably an authorized BMW Motorrad retailer.
- » The operating and road safety of the vehicle remains unchanged.
- » The best-possible value retention of the vehicle is ensured.

## Operation

Ignition steering lock .....	74	Electronic chassis and suspension adjustment (D-ESA) .....	93
Ignition with Keyless Ride .....	75	Riding mode .....	96
EWS Electronic immobilizer .....	78	PRO riding mode .....	99
Emergency on/off switch (kill switch) .....	79	PRO riding mode with connectivity .....	101
Lights .....	80	Cruise-control system .....	102
Hazard warning flasher .....	81	Tire pressure control (TPC/RDC) .....	105
Turn indicators .....	82	Heated grips .....	105
Multifunction display .....	83	Seat .....	106
SETUP .....	85	Operating Instructions .....	107
Time and date .....	86		
General settings on the multifunction display .....	88		
Antilock Braking System (ABS) .....	89		
Traction control (ASC/DTC) .....	91		

## Ignition steering lock

### Ignition keys

You are provided with 2 ignition keys.

Should you lose your keys please refer to the notes regarding the electronic immobilizer (EWS) (►► 78).

The ignition lock, fuel filler cap and seat lock are operated with the same key.

- with case<sup>OA</sup>
- with topcase<sup>OA</sup>

The cases and the topcase can also be ordered with locks for the same key on request. Please contact a specialist workshop for this purpose, preferably a BMW Motorrad retailer.

### Locking handlebars

- Turn handlebars to left.



- Turn key to position **1** while moving handlebars slightly.
  - » Ignition, lights and all electrical circuits switched off.
  - » Steering lock locked.
  - » Key can now be removed.

## Switching on ignition



- Turn key to **1** position.
  - » Parking lights and all function circuits switched on.
  - » Engine can be started.
  - » Pre-Ride-Check is carried out. (►► 148)
  - » ABS self-diagnosis is performed. (►► 149)
  - » ASC self-diagnosis is performed. (►► 149)
- with riding modes Pro<sup>OE</sup>
  - » DTC self-diagnosis is performed. (►► 150)◁

## Welcome light

- Switch on the ignition.
- » The parking lamp briefly lights up.
- with LED additional headlight<sup>OA</sup>
- » The supplementary LED headlights briefly light up.◀

## Switch off ignition



- Turn key to **1** position.
- » Light switched off.
- » Handlebars not locked.
- » Key can now be removed.

- » Electrically powered accessories remain operational for a limited period of time.
- » Battery charging possible via the on-board socket.

## Ignition with Keyless Ride

- with Keyless Ride<sup>OE</sup>

## Ignition keys

### NOTICE

The indicator light for the radio-operated key flashes as long as the radio-operated key is being searched for.

If the radio-operated key or the emergency key is detected, it goes out.

If the radio-operated key or the emergency key is not detected, it lights up briefly.◀

You are provided with one radio-operated key and one emergency

key. Should you lose your keys, refer to the notes regarding the electronic immobilizer (EWS) (▮▮▮ 78).

The ignition, tank filler cap and anti-theft alarm system are activated with the radio-operated key. The seat lock, Topcase and case can be operated manually.

### NOTICE

When the range of the radio key is exceeded (e.g. in case or Topcase), the motorcycle cannot be started.

If the radio-operated key continues to be missing, the ignition is switched off after approx. 1.5 minutes to protect the battery charge.

It is advisable to carry the radio-operated key directly on your person (e.g. in a jacket pocket) and to also carry the emergency key as an alternative.◀



Range of Keyless Ride  
radio-operated key

– with Keyless Ride<sup>OE</sup>

Approx. 3.3 ft (Approx. 1 m)◁

## Locking handlebars

### Requirement

Handlebars are turned to the left.  
Key remote is within reception range.

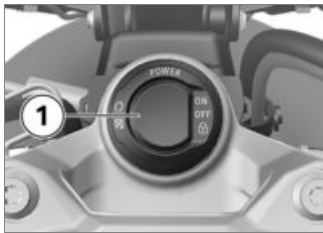

- Press and hold button **1**.
- » Steering lock audibly locks.
- » Ignition, lights and all electrical circuits switched off.

- To unlock the steering lock, briefly press button **1**.

## Switching on ignition

### Requirement

Key remote is within reception range.

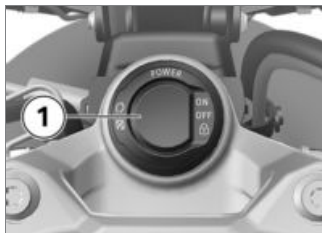

- The ignition can be activated in **two** ways.

### Version 1:

- Briefly press button **1**.
- » Parking light and all function circuits are switched on.

– with LED additional headlight<sup>OA</sup>

- » LED additional headlights are switched on.◁
- » Pre-Ride-Check is carried out. (▣▶ 148)
- » ABS self-diagnosis is performed. (▣▶ 149)
- » ASC self-diagnosis is performed. (▣▶ 149)

### Version 2:

- Steering lock is locked, press and hold button **1**.
- » Steering lock is unlocked.
- » Parking lights and all function circuits switched on.
- » Pre-Ride-Check is carried out. (▣▶ 148)
- » ABS self-diagnosis is performed. (▣▶ 149)
- » ASC self-diagnosis is performed. (▣▶ 149)

## Switch off ignition

### Requirement

Key remote is within reception range.

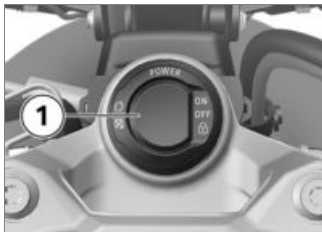

- The ignition can be deactivated in **two** ways.

### Version 1:

- Briefly press button **1**.
  - » Light is switched off.
  - » Handlebars are not locked.

### Version 2:

- Turn handlebars to left.
- Press and hold button **1**.
  - » Light is switched off.
  - » Steering lock is locked.

## Battery of the key fob transmitter is empty or the key fob transmitter is lost



- Should you lose your keys, refer to the information regarding the electronic immobilizer (**EWS**).
- Should you loose the radio-operated key while driving, the motorcycle can be started by using the emergency key.
- If the radio-operated key battery is dead, you can start the vehicle simply by inserting the

folded-in key into the ring antenna under the vehicle's seat.

- Removing seat (►► 106).
- Insert emergency key or the dead folded-in radio-operated key **1** into the ring antenna **2**.



### NOTICE

The emergency key or dead folded-out radio-operated key must be **inserted** into the opening of the ring antenna.◀



Period in which the engine must be started. Then unlocking must be repeated.

30 s

- » Pre-Ride-Check is carried out.
  - Key has been detected.
  - Engine can be started.
- Starting the engine (►► 147).

## Replacing the battery of the key fob transmitter

### Requirement

The key fob transmitter does not react because the battery is weak.

KEYLO! appears on the display.

- Replace battery.

– with Connectivity<sup>OE</sup>

 Key remote battery low. Limited central locking function. Change battery.<

- Replace battery.<

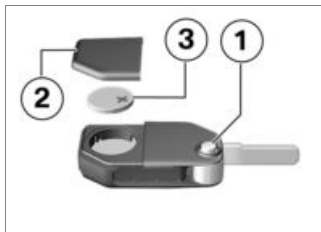

- Press button **1**.
  - » Key bit folds open.
- Press battery cover **2** upward.
- Remove battery **3**.
- Dispose of the old battery in accordance with legal regulations. Do not dispose of the battery in the household waste.



### ATTENTION

#### Unsuitable or improperly inserted batteries

Component damage

- Use a battery compliant with the manufacturer's specifications.

- When inserting the battery, make sure that the polarity is correct.<
- Insert the new battery with the positive terminal up.



Battery type

For Keyless Ride radio-operated key

CR 2032

- Install battery cover **2**.
  - » Red LED in instrument panel flashes.
  - » The key fob transmitter is working again.

## EWS Electronic immobilizer

The motorcycle's electronics monitor the data stored in the ignition key through a ring antenna incorporated in the ignition lock/wireless lock. The engine

control unit does not enable an engine start until the ignition key has been recognized as "authorized" for your motorcycle.

## NOTICE

An additional key attached to the same ring as the ignition key / radio-operated key used to start the engine could "irritate" the electronics, in which case the enabling signal for the engine start is not issued.

Always store further vehicle keys separately from the ignition key / radio-operated key. ◀

If you lose an ignition key, you can have it disabled by your BMW Motorrad retailer. When having a key disabled you should also bring all of the motorcycle's remaining keys with you. The engine can no longer be started using a disabled ignition

key; however, a disabled ignition key can be enabled again. Emergency and spare keys are only available through an authorized BMW Motorrad retailer. The keys are part of an integrated security system, so the retailer is under an obligation to check the legitimacy of all applications for replacement/extra ignition keys.

## Emergency on/off switch (kill switch)



- 1 Emergency on/off switch (kill switch)

## WARNING

### Operation of the emergency ON/OFF switch when riding

Danger of falling due to blocking of rear wheel

- Do not operate the emergency ON/OFF switch when riding. ◀

The engine can be switched off easily and quickly using the emergency on/off switch.

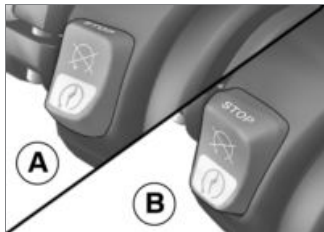

- A** Engine is switched off  
**B** Operating position

## Lights

### Low-beam headlight and parking lights

The parking lights come on automatically when the ignition is switched on.



#### NOTICE

The parking lights are a strain on the battery. Do not leave the ignition switched on longer than absolutely necessary. ◀

The low-beam headlight comes on automatically under the following conditions:

- If the engine starts.
- If the vehicle is pushed while the ignition is on.



#### NOTICE

With the engine switched off, you can switch on the lights by switching on the high-beam headlight with the ignition switched on or by operating the headlight flasher. ◀

### High beam and headlight flasher

- Switching on ignition (➡ 74).



- Press switch **1** toward front to switch on high beam.
- Pull switch **1** toward rear to actuate headlight flasher.

### Headlight courtesy delay feature

- Turn off ignition.



- Immediately after turning off the ignition, pull switch **1** back and hold until the headlight courtesy delay feature turns on.
  - » The vehicle lights light up for one minute and then turn off automatically.
  - This can be used after parking the vehicle in order to illuminate the path to the house door, for instance.

## Parking lights

- Switch off ignition (➡ 75).



- Immediately after switching off the ignition, push button **1** to left and hold it until the parking lamps come on.
- Switch ignition on and then off again to switch off parking light.

## Hazard warning flasher Operating hazard warning flashers

- Switch on the ignition.

### NOTICE

The hazard warning flashers place a strain on the battery. Do not use the hazard warning

flashers for longer than absolutely necessary. ◀

### NOTICE

If a turn signal button is pressed when operating readiness is present, the turn signal function replaces the hazard warning lights function for the duration of operation. If the turn signal button is no longer pressed, the hazard warning lights function is activated again. ◀



- Press button **1** to switch on the hazard warning lights system.
- » Ignition can be switched off.
- To switch off the hazard warning lights system, switch on the ignition, as required, and press button **1** once again.

## Turn indicators

### Operating turn signals

- Switch on the ignition.



- Press button **1** to left to switch on left-side turn signals.
- Press button **1** to right to switch on right-side turn signals.
- Move button **1** to center position to switch off turn signals.

## Comfort turn signals



When button **1** is pressed to the right or left, the turn signal automatically turns off under the following conditions:

- Speed is under 18 mph (30 km/h): after distance covered of 165 ft (50 m).
- Speed is between 18 mph and 60 mph (30 km/h and 100 km/h): after covering a particular distance depending on the speed or when accelerating.

- Speed is above 60 mph (100 km/h): after turn signal flashes five times.

When button **1** is pressed and held slightly longer to the right or left, the turn signals will only turn off automatically after covering the distance depending on the speed.

## Multifunction display

### Selecting display at the top

- Switching on ignition (☰➔ 74).



- Press the top of the MENU rocker button **1** briefly to select the upper display line **3**.

The following values can be displayed:

- Odometer ODO
- Trip distance 1 TRIP 1
- Trip distance 2 TRIP 2
- Automatic trip distance TRIP A is automatically reset if at least 6 hours have passed after switching off the ignition and the date has changed.

- Call up menu for settings: SETUP ENTER (only displayed when the vehicle is stationary)

### Selecting display at the bottom



- Briefly press MENU rocker button down **2** to select the option in the bottom line of the display **4**.

The following values can be displayed:

- Range RANGE
- Average consumption CONS 1
- Average consumption CONS 2
- Current consumption CONS C

- Outside temperature EXTEMP
- Coolant temperature ENGTMP
- Average speed SPEED 0
- with tire pressure monitor (TPM)<sup>OE</sup>
- Tire pressure monitor RDC<
- Battery voltage VOLTGE
- Driving time RDTIME
- Date DATE

## Resetting the trip odometer

- Switch on the ignition.
- Selecting the trip odometer.
- » The desired trip odometer is displayed.



- Press and hold MENU rocker button up **1** until the trip odometer **3** has been reset.
- » Trip mileage = 0 . 0

## Resetting average data

- Switch on the ignition.
- Repeatedly press the MENU rocker button down until the average fuel consumption or average speed is displayed as desired.



- Hold MENU rocker button down **2** until the displayed average value **4** is reset.
- » Average value = - - - - -

## Reset driving time

- Switch on the ignition.
- Repeatedly press MENU rocker button down **2** until driving time RDTIME is displayed.



- Press MENU rocker button down **2** and hold until driving time RDTIME **3** has been reset.
- » Driving time starts at 00:00:00

## SETUP

### Select SETUP Requirement

The motorcycle is stopped.



- Repeatedly press MENU rocker button up **1** until SETUP ENTER **3** is displayed.
- Press and hold MENU rocker button up **1** to start SETUP.
- Briefly press the MENU rocker button up **1** to select the following parameters in SETUP:
  - with anti-theft alarm system (DWA)<sup>OE</sup>
  - Activate alarm function of anti-theft alarm system automatically after switching off the ignition DWA ON or leave switched off DWA OFF.<
  - Set time display CLOCK.
  - with preparation for navigation system<sup>OE</sup>
  - Display time from global positioning system GPS ON or time from on-board computer GPS OFF.<
  - Set date DATE.
  - Switch upshift recommendation off ECOSFT OFF or on ECOSFT ON.
  - Adjust brightness of backlighting for instrument cluster BRIGHT.
  - with tire pressure monitor (TPM)<sup>OE</sup>
  - Switch minimum pressure warning off RDC PRO ON or on RDC PRO OFF. The minimum pressure warning can only be switched off in off-road mode.<
  - Adjust units UNIT.
  - Reset displays RESET.
  - Exit SETUP EXIT.

## Exit SETUP

### Requirement

There are four ways to exit SETUP.

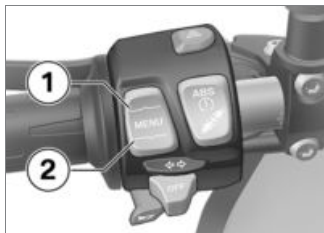

- Press and hold MENU rocker button up **1**.
- » SETUP ENTER is displayed.
- Alternatively: repeatedly press MENU rocker button up **1** until SETUP EXIT is displayed.
- Press and hold MENU rocker button down **2**.
- » SETUP ENTER is displayed.
- Alternative: turn the ignition off and on again.

- » SETUP ENTER is displayed.
- Alternatively: drive off.

	Speed for operation in SETUP
--	------------------------------

max 6 mph (max 10 km/h)

- » Once the permitted speed for operation is exceeded, SETUP will close.
- » ODO is displayed.
- » All settings are saved regardless of which method is used to exit SETUP.

## Time and date

### Set clock

#### Requirement

The motorcycle is stopped.

- Switch on the ignition.
- Select SETUP (⏏ 85).
- » SETUP CLOCK is displayed.

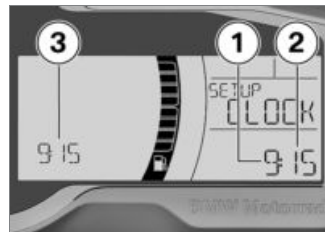

- Press and hold MENU rocker button down to set the hours.
- » The hours **1** flash.
- Briefly press MENU rocker button up to increase the hours.
- Briefly press MENU rocker button down to decrease the hours.
- If the desired hours are set, press down and hold the MENU rocker button.
- » The minutes **2** flash.
- Briefly press MENU rocker button up to increase the minutes.

- Briefly press MENU rocker button down to decrease the minutes.
- If the desired minutes are set, press down and hold the MENU rocker button.
  - » The minutes **2** stop flashing.
- Check setting on the time display **3**.
  - » The clock is now set.
- Press up and hold MENU rocker button.
  - » SETUP ENTER is displayed.

## Setting the date

### Requirement

The motorcycle is stopped.

- Switch on the ignition.
- Select SETUP (▣➡ 85).
- » SETUP DATE is displayed.

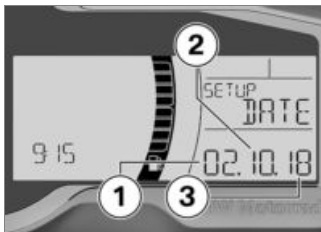

- Press down and hold MENU rocker button.
  - » Month **1** flashes.
- Briefly press MENU rocker button up to increase the month.
- Briefly press MENU rocker button down to decrease the month.
  - If the desired month is set, press down and hold the MENU rocker button.
    - » Day **2** flashes.
- Briefly press MENU rocker button up to increase the day.
- Briefly press MENU rocker button down to decrease the day.
  - If the desired day is set, press down and hold the MENU rocker button.
    - » Year **3** flashes.
- Briefly press MENU rocker button up to increase the year.
- Briefly press MENU rocker button down to decrease the year.
  - If the desired year is set, press down and hold the MENU rocker button.
    - » Year **3** stops flashing.
    - » The clock is now set.
- Press up and hold MENU rocker button.
  - » SETUP ENTER is displayed.

## General settings on the multifunction display

### Adjust brightness of backlighting for instrument cluster

#### Requirement

The vehicle is at a standstill.

- Switch on the ignition.
- Select SETUP (☰ 85).
- Press MENU rocker button up **1** repeatedly until SETUP BRIGHT is displayed.



- Repeatedly press MENU rocker button down **2** until the desired

brightness of the backlighting is set.

- Press and hold MENU rocker button up **1** to exit SETUP.
- » SETUP ENTER appears on the display.

### Adjust units

#### Requirement

The vehicle is at a standstill.

- Switch on the ignition.
- Select SETUP (☰ 85).
- Press MENU rocker button up **1** repeatedly until SETUP UNIT ENTER is displayed.
- Press MENU rocker button down **2** and hold to activate SETUP UNIT.
- » SETUP UNIT SPEED is displayed.
- Press MENU rocker button up **1** to select each of the parameters in SETUP UNIT:

- Change fuel consumption indicator to L/100, KM/L or MPG
- Change tire pressure monitor unit (RDC) to BAR, PSI or KPA
- Change temperature display unit to °C or °F
- Change time display to 24H or 12H
- Change date format to DMY or MDY



- Press MENU rocker button down **2** briefly until the desired unit **3** of the speedometer or odometer is set.
- If the setting is to be ended, repeatedly press

the MENU rocker button up **1** until SETUP UNIT EXIT is displayed.

- Press MENU rocker button down **2** and hold to leave SETUP UNIT.
- » SETUP RESET is displayed.



- If the units are to be reset to the factory settings, repeatedly press the MENU rocker button up **1** until SETUP UNIT RESET is displayed.
- Press the MENU rocker button down **2** and hold until the RE-SET display **3** flashes.

- » Units have been reset to factory settings.
- » The display SETUP UNIT EXIT is shown.
- Press MENU rocker button down **2** and hold to leave SETUP UNIT.
- » SETUP RESET is displayed.

### Resetting SETUP

- Switch on the ignition.
- Select SETUP (▣▣▣ 85).



- Briefly press the top of the MENU rocker button **1**

repeatedly until SETUP RESET is displayed.

- Press and hold the bottom of the MENU rocker button **2** until SETUP is reset.



### NOTICE

The SETUP RESET function also resets the date and time to their standard values.◀

- » The time 12:00 is displayed.
- Press and hold the top of the MENU rocker button **1** to exit SETUP.
- » SETUP ENTER is displayed.

### Antilock Braking System (ABS)

#### Switching off the ABS function

- Switching on ignition (▣▣▣ 74).

## NOTICE

The ABS function can also be deactivated while driving.◀



- Press and hold button **1** until the ABS indicator and warning light changes its display behavior.

– with Connectivity<sup>OE</sup>

Immediately after pressing the button **1**, the current ASC/DTC system status and ABS system status **ON** are displayed.◀

» First, the ASC/DTC indicator and warning light changes its

behavior. Press and hold button **1** until the ABS indicator and warning light reacts. In this case, the ASC/DTC setting does not change.



ABS indicator light lights up.

– with Connectivity<sup>OE</sup>

Possible ABS system status **OFF!** is displayed.◀

- Release button **1** after changeover of the ABS system status.



ABS indicator light continues to be lit up.

– with Connectivity<sup>OE</sup>

ASC/DTC system status remains unchanged and new ABS system status **OFF!** is displayed for a short time.◀

» The ABS function is switched off.

## Switch on ABS function



- Press and hold button **1** until the ABS indicator and warning light changes its display behavior.

– with Connectivity<sup>OE</sup>

Immediately after pressing the button **1**, the current ASC/DTC system status and ABS system status **OFF!** are displayed.◀



ABS indicator light goes out, and starts to flash if self-diagnosis has not been completed.

– with Connectivity<sup>OE</sup>

Possible ABS system status ON is displayed.<

- Release button **1** after changeover of the ABS system status.



ABS indicator light remains off or continues to flash.

– with Connectivity<sup>OE</sup>

ASC/DTC system status remains unchanged and new ABS system status ON is displayed for a short time.<

- » The ABS function is switched on.
- As an alternative, the ignition can also be turned off and then on again.



If the ABS indicator and warning light lights up after switching the ignition off and on and then continuing driving above the minimum speed, an ABS fault has occurred.

min 6 mph (min 10 km/h)

– with riding modes Pro<sup>OE</sup>

- If the coding plug is not installed, the ignition can also be switched off and then on again as an alternative.<

## Traction control (ASC/DTC)

### Switching off the ASC/DTC function

- Switching on ignition (➡ 74).



## NOTICE

The ASC/DTC function can also be deactivated while riding.<



- Press and hold button **1** until the ASC/DTC indicator and warning light changes its display behavior.
- with Connectivity<sup>OE</sup>  
Immediately after pressing button **1**, the ASC/DTC system status ON and current ABS system status are displayed.<

 ASC/DTC indicator and warning light lights up.

– with Connectivity<sup>OE</sup>

Possible ASC system status OFF! is displayed.<1

- Release button **1** after switchover of the ASC/DTC system status.

 ASC/DTC indicator and warning light remains illuminated.

– with Connectivity<sup>OE</sup>

The new ASC/DTC system status OFF! is displayed briefly. The ABS system status remains unchanged.<1

- » The ASC/DTC function is switched off.

## Switching on the ASC/DTC function



- Press and hold button **1** until the ASC/DTC indicator and warning light changes its display behavior.

– with Connectivity<sup>OE</sup>

Immediately after pressing button **1**, the ASC/DTC system status OFF! and current ABS system status are displayed.<1

 ASC/DTC indicator and warning light no longer lights up and begins to flash if

self-diagnosis has not been completed.

– with Connectivity<sup>OE</sup>

Possible ASC system status ON is displayed.<1

- Release button **1** after changeover of the status.

 ASC/DTC indicator and warning light remains off or continues to flash.

– with Connectivity<sup>OE</sup>

The new ASC/DTC system status ON is displayed briefly. The ABS system status remains unchanged.<1

- » The ASC/DTC function is switched on.
- If the coding plug is not installed, the ignition can also be switched off and then on again as an alternative.



If the ASC/DTC indicator and warning light lights up after switching the ignition off and on and then continuing riding with the following minimum speed, an ASC/DTC fault has occurred.

min 3 mph (min 5 km/h)

- For more information on ASC/DTC traction control, see Chapter "Technology in detail".
- » How does traction control work? (➡ 166)

## Electronic chassis and suspension adjustment (D-ESA)

– with Dynamic ESA<sup>OE</sup>

### Adjustment options

Using the electronic suspension adjustment Dynamic ESA, you can adjust the damping on the rear wheel comfortably to the

road surface. Three damper settings and three spring preload steps are available.

### Display suspension setting



- Switching on ignition (➡ 74).
- Press button **1** briefly to display current setting.

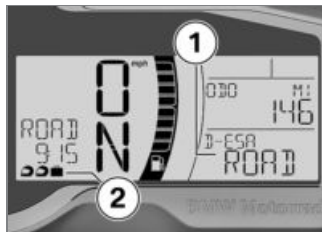

The damping action is displayed in the multifunction display in area **1**, and spring preload is indicated in area **2**.

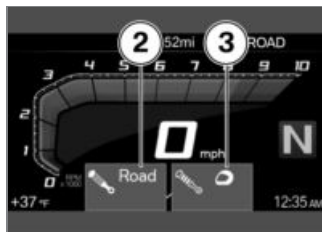

– with Connectivity<sup>OE</sup>

Immediately after pressing the button **1**, the chassis and

suspension adjustments for damping **2** and spring preload **3** are displayed.◀

» The display automatically disappears again after a short time.

## Setting suspension compliance

- Switching on ignition (➡ 74).



- Press button **1** briefly to display current setting.

To set the damping rate:

- Repeatedly press button **1** briefly until the desired setting is displayed.



### NOTICE

The damping cannot be adjusted while the motorcycle is being ridden.◀

The following settings are available:

- ROAD: damping for comfortable riding on roads
- DYNA: damping for dynamic riding on roads
- ENDURO: damping for off-road riding. Is only available in the ENDURO or ENDURO PRO riding modes and can not be adjusted further in these riding modes.

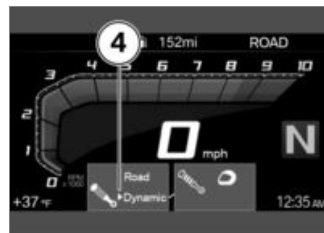

– with Connectivity<sup>OE</sup>  
The selection arrow **4** is displayed.◀

» The selection arrow **4** goes away after the changeover of the status.

– with Connectivity<sup>OE</sup>  
The following settings are available:

- Road: Damping for comfortable road travel
- Dyna.: Damping for dynamic road travel
- Enduro: Damping for off-road travel. Only available in the riding modes ENDURO or ENDURO

PRO, and cannot be further adjusted in these riding modes.

– with Connectivity<sup>OE</sup>

A message is displayed if no setting is possible in the selected riding mode. Example: In ENDURO riding mode damp. not adjustable.<



To set the spring preload:

- Starting the engine (→ 147).
- Repeatedly press and hold button **1** until the desired setting is displayed.

## NOTICE

The spring preload cannot be adjusted while the motorcycle is being ridden.<

The following settings are available:



One-up



One-up with luggage



Two-up (with luggage)

– with Connectivity<sup>OE</sup>

The following message is displayed if no setting is possible: Load adjust. only avail. when halted.<

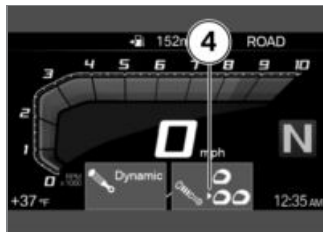

– with Connectivity<sup>OE</sup>

The selection arrow **4** is displayed.<

- » The selection arrow **4** goes away after the changeover of the status.
- Wait for the adjustment routine to finish before starting off again.
- » If the button **1** is not pressed for an extended period, the damping action and the spring preload will be adjusted to the displayed settings.

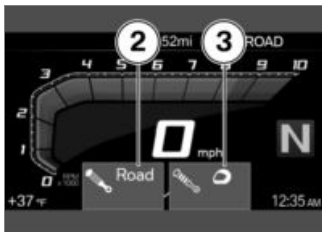

– with Connectivity<sup>OE</sup>

The new chassis and suspension adjustments for damping **2** and spring preload **3** are displayed for a short time.◀

## Riding mode

### Use of the riding modes

BMW Motorrad has developed 5 riding scenarios for your motorcycle from which you can select the one matching your situation:

- Riding on wet roads.
- Riding on dry roads.

- with riding modes Pro<sup>OE</sup>
- Sporty riding on dry roads.
- Riding under light off-road conditions.
- Sporty riding off-road.

For each of these scenarios, the optimum interaction between throttle response, ABS control and ASC/DTC control is provided.



### NOTICE

You can find more detailed information regarding the riding modes available for selection in the "Technology in detail" chapter.◀

– with Dynamic ESA<sup>OE</sup>

The chassis and suspension adjustments can also be adapted in the selected scenario.

More detailed information about the riding modes can be found in the "Technology in Detail" (▶▶▶ 168) chapter.

## Select riding mode

- Switching on ignition (▶▶▶ 74).



- Press button **1**.

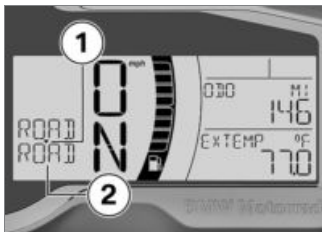

The selection arrow **1** and the first selectable riding mode **2** are displayed.

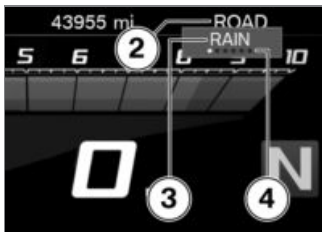

– with Connectivity<sup>OE</sup>

The active riding mode **2** fades into the background and the first selectable riding mode **3** is

displayed. The guide **4** shows how many riding modes are available.◀



### ATTENTION

#### Turning on off-road mode (Enduro and Enduro Pro) when in road mode

Risk of falling due to unstable riding conditions when braking or accelerating in the ABS or ASC/DTC control range

- Switch off-road mode (Enduro and Enduro Pro) during off-road riding on only.◀

- Press button **1** repeatedly until the selection arrow is shown next to the desired riding mode.

### NOTICE

When selecting the Enduro PRO mode, remember the restrictions on ABS control intervention at the rear wheel (see the chapter "Technology in detail").◀

The following ride modes can be selected:

- RAIN: For journey on a rain-slicked roadway.
- ROAD: For journey on a dry roadway.

– with riding modes Pro<sup>OE</sup>

The following riding modes are additionally available for selection:

- DYNAMIC: For a dynamic journey on a dry roadway.

– **ENDURO**: For off-road journey with road tires.<

– with riding modes Pro<sup>OE</sup>

With the encoding plug installed, **ENDURO PRO** replaces the riding mode **ENDURO**.

– **ENDURO PRO**: For off-road journey with rough-tread off-road tires.<

» When the motorcycle is stationary, the selected riding mode is activated after approx. 2 seconds.

» The new riding mode is activated during operation under the following conditions:

– Throttle is at idle.

– Brake is not engaged.

» After the new riding mode is activated, the clock is displayed again.

» The riding mode selected and its associated engine-characteristic, ABS, ASC/DTC and

Dynamic ESA settings are retained even after the ignition has been switched off.

### Installing encoding plug

– with riding modes Pro<sup>OE</sup>

- Switch off ignition (▶▶▶ 75).
- Removing seat (▶▶▶ 106).

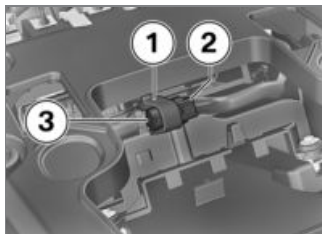

- Remove rubber band **1**.

### ATTENTION

#### Penetration of dirt and moisture in the open connector

Malfunctions

- After removing the encoding plug, refit the cover cap.<
- Press in locking mechanism **2** and pull off the cover cap **3**.

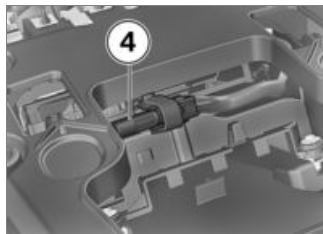

- Install encoding plug **4**.

### NOTICE

The coding plug and protective cap are stored in the seat along with the tool kit.<

» Locking mechanism **2** engages.

- Install rubber band **1**.
- Switch on the ignition.

## NOTICE

If the coding plug is connected, deactivated riding safety systems remain deactivated even after the ignition is turned off and on. ◀



Symbol for coding plug is displayed.

- Select riding mode (▶▶▶ 96).
- Installing seat (▶▶▶ 107).

## PRO riding mode

– with riding modes Pro<sup>OE</sup>

### Adjustment options

The PRO riding modes can be adjusted individually.

### Start SETUP MODE

- Installing encoding plug (▶▶▶ 98).
- Switching on ignition (▶▶▶ 74).



- Repeatedly briefly press the MODE button **1** until **2** SETUP ENTER appears in the top line of the display.
- Press and hold button **1** to start the SETUP menu.
  - » SETUP MODE ENDURO PRO ENTER is displayed.



- Press and hold button **2** to start SETUP MODE.
  - » SETUP ENGINE is displayed.

### Set Enduro PRO

– with riding modes Pro<sup>OE</sup>

- Start SETUP MODE (▶▶▶ 99).
  - » SETUP ENGINE is displayed.



- Press button **2** briefly to set ENGINE to RAIN, ROAD or DYNA.
- Press button **1** briefly.
  - » SETUP DTC is displayed.
- Press button **2** briefly to set DTC to ENDURO or ENDURO PRO.
- Press button **1** briefly.
  - » SETUP ABS is displayed.
- Press button **2** briefly to set ABS to ENDURO or ENDURO PRO.
- Press button **1** briefly.

» SETUP MODE RESET is displayed.



- Press button **1** briefly to keep the settings.
  - » SETUP MODE EXIT is displayed.
- Alternatively, press and hold button **2** to reset all parameters.
  - » Factory setting for riding mode Enduro PRO is applied:
    - DTC: ENDURO PRO
    - ABS: ENDURO PRO
    - ENGINE: DYNA
  - » RESET flashes 3 times.

» SETUP MODE EXIT is displayed.



- Press button **1** briefly to return to the start of settings.
  - » SETUP ENGINE is displayed.
- Alternatively, press and hold button **2** to leave SETUP MODE.



SETUP MODE ENDURO PRO  
ENTER is displayed.



- Repeatedly press button **1** briefly until **SETUP EXIT** is displayed.
- Press and hold button **1**.

» The on-board computer readings appear on the display.

## PRO riding mode with connectivity

- with riding modes Pro<sup>OE</sup>
- with Connectivity<sup>OE</sup>

## Set up riding mode PRO

- with riding modes Pro<sup>OE</sup>
- Installing encoding plug (▶▶▶ 98).
- Switching on ignition (▶▶▶ 74).
- Call up menu **Settings**, **Vehicle settings**.
- » The **ENDURO PRO** riding mode can be adapted.
- Select riding mode and confirm.

## Set Enduro Pro

- with riding modes Pro<sup>OE</sup>

- with Connectivity<sup>OE</sup>
- Set up riding mode PRO (▶▶▶ 101).

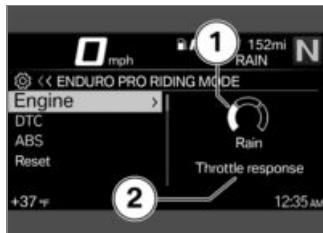

The **Engine** system is selected. The current setting is displayed as a diagram **1** with explanations on the system **2**.

- Select system and confirm.



You can browse through the possible settings **3** and the related descriptions **4**.

- Adjust system.
  - » The systems **Engine**, **DTC** and **ABS** can be adjusted in the same way.
- The settings can be reset to the factory settings:
- Reset riding mode settings (▮▮▮▮▶ 102).

## Reset riding mode settings

- Set up riding mode **PRO** (▮▮▮▮▶ 101).

- Select **Reset** and confirm.
  - » The following factory settings apply for **ENDURO PRO** riding mode:
    - **DTC**: Enduro Pro
    - **ABS**: Enduro Pro
    - **ENGINE**: Dynamic

## Cruise-control system

- with cruise control<sup>OE</sup>

## Display while adjusting (road sign detection not active)



The symbol **1** for the cruise control is displayed in the Pure Ride view and in the upper status line.

## Display while adjusting (road sign detection active)



The symbol **1** for the cruise control is displayed in the Pure Ride view and in the upper status line.

## Switch on cruise control Requirement

Cruise control only becomes available after changing out of the riding modes Enduro or Enduro Pro.

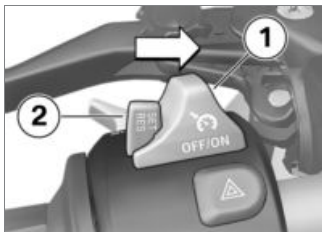

- Slide switch **1** to the right.  
» Button **2** can be operated.

## Store speed

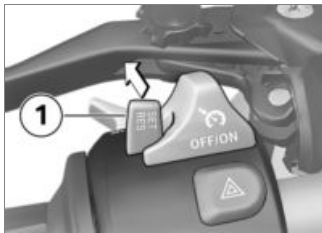

- Briefly press button **1** forward.

 Adjustment range of the cruise control

19...130 mph (30...210 km/h)

 Cruise-control indicator light lights up.

- » The motorcycle maintains your current cruising speed and the setting is saved.

## Accelerating

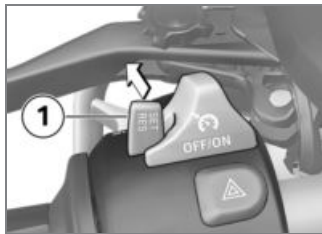

- Short-press button **1** forward.  
» The speed is increased by 0.6-1.2 mph (1-2 km/h) each time the button is pressed.

- Press button **1** forward and hold.
- » The motorcycle accelerates steplessly.
- » If button **1** is no longer pressed, the speed reached is maintained and saved.

### Decreasing speed

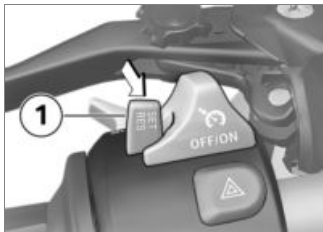

- Briefly press button **1** backward.
- » The speed is reduced by 0.6-1.2 mph (1-2 km/h) each time the button is pressed.
- Press button **1** back and hold.

- » The motorcycle decelerates steplessly.
- » If button **1** is no longer pressed, the speed reached is maintained and saved.

### Deactivate cruise control

- Operate brakes, coupling or throttle grip (ease the throttle beyond the default setting) to deactivate the cruise control.
- » Cruise-control indicator light goes out.

### Resuming former cruising speed

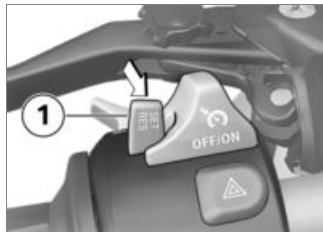

- Briefly push button **1** back to return to the speed saved beforehand.



### NOTICE

Opening the throttle does not deactivate the cruise-control system. If you release the throttle grip, the motorcycle will decelerate only to the cruising speed saved in memory, even though you might have intended slowing to a lower speed. ◀



Cruise-control indicator light lights up.

## Switch off cruise-control system

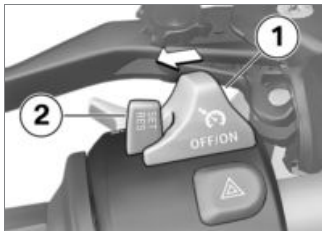

- Push switch **1** to the left.
- » The system is deactivated.
- » Button **2** is locked.

## Tire pressure control (TPC/RDC)

- with Connectivity<sup>OE</sup>
- with tire pressure monitor (TPM)<sup>OE</sup>
- with riding modes Pro<sup>OE</sup>

## Switch minimum pressure warning on or off

- The minimum pressure of the tires can be freely selected. A minimum pressure warning can be displayed when the minimum pressure has been reached.
- Call up Settings, Vehicle settings, RDC menu.
- Switch Nom. pressure warning on or off.

## Heated grips

– with heated grips<sup>OE</sup>

## Operating heated grips

- Starting the engine (➔ 147).



### NOTICE

The heated grips option can only be activated when the engine is running.◀



### NOTICE

The increase in power consumption caused by the heated grips can drain the battery if you are riding at low engine speeds. If the battery is inadequately charged, the heated grips are switched off to ensure starting capability.◀



- Press the button **1** repeatedly until the desired heating level **2** is shown in front of the heated grip symbol **3**.

The handlebar grips can be heated at three different levels.

The third level is used for fast heating of the grips; the switch should then be switched back to the second or first level.



75 % heating output



55 % heating output



35 % heating output

» If no further changes are made the selected heating level is adopted as the setting.

– with Connectivity<sup>OE</sup>

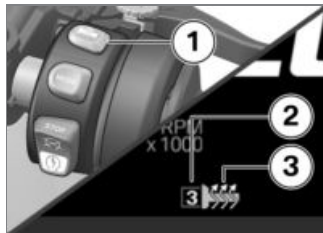

- Press the button **1** repeatedly until the desired heating level **2** is shown in front of the heated grip symbol **3**.

The handlebar grips can be heated at three different levels. The third level is used for fast heating of the grips; the switch should then be switched back to the second or first level.



75 % heating output



55 % heating output



35 % heating output

» If no further changes are made the selected heating level is adopted as the setting.

- To switch off the heated grip, press button **1** repeatedly until heated grip symbol **3** is not shown anymore in the display.

## Seat

### Removing seat Requirement

Motorcycle is parked, ensuring that support surface is firm and level.

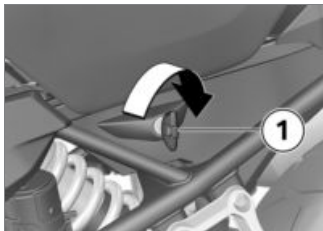

- Turn the ignition key clockwise in the seat lock **1**.
- » Seat bench is unlocked.

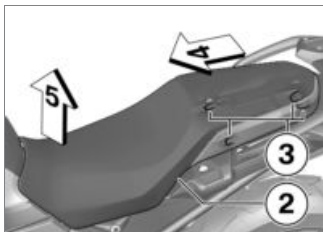

- Press the seat bench **2** in direction of arrow **4** out of the brackets **3**.

- Remove seat bench in direction of arrow **5** and place on the rubber buffers on a clean surface.

### Installing seat

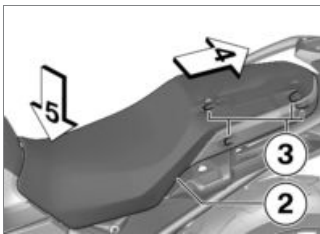

- Push seat bench **2** in direction of arrow **4** into the brackets **3**.
- Forcibly push seat bench in direction of arrow **5**.
- » The seat bench will audibly engage.

## Operating Instructions

### Stow rider's manual

- Place rider's manual in the pouch provided.



- Close the opening of the pouch as tightly as possible, then seal the velcro **1**.
- Stow the pouch in the rear of the vehicle.



## **TFT display**

General notes.....	110
Principle .....	111
Pure Ride view.....	117
General settings .....	118
Bluetooth .....	120
My vehicle .....	123
On-board computer.....	126
Navigation .....	126
Media.....	128
Phone .....	129
Display software version .....	130
Display license information.....	130

## General notes

### Warnings



#### WARNING

#### Operation of a smartphone while riding or with the engine running

Accident hazard

- Observe the relevant road traffic regulations.
- Do not use while riding (except for applications without operation such as telephony via the hands-free system).◀



#### WARNING

#### Distraction from traffic conditions and loss of control

Risk of accident through the use of integrated information systems and communication devices during the journey

- Operate these systems or devices only if the traffic situation allows.
- If necessary, stop and operate the system or devices at a standstill.◀

### Connectivity functions

Connectivity functions include media, telephony and navigation. Connectivity functions can be used if the TFT display is connected with a mobile end device and a helmet (☞ 120). You can find more information about the Connectivity functions at: [bmw-motorrad.com/connectivity](http://bmw-motorrad.com/connectivity)



#### NOTICE

If the fuel tank is between the mobile end device and the TFT display, the Bluetooth connection may be restricted. BMW Motorrad recommends

storing the mobile end device above the fuel tank (e.g. in the jacket pocket).◀



#### NOTICE

Depending on the mobile end device, the scope of the Connectivity functions may be limited.◀

### BMW Motorrad Connected App

With the BMW Motorrad Connected App, you can call up information about the vehicle and usage. To use some features such as navigation, the app must be installed on the mobile end device and be connected to the TFT display. The app starts the route guidance and adapts the navigation.



## NOTICE

On some mobile devices, e.g. with operating system iOS, the BMW Motorrad Connected App must be called up before using. ◀

### Notice concerning current status

After the editorial deadline, there may be updates to the TFT display. For this reason, some aspects of your motorcycle may vary from the descriptions in this Rider's Manual. Updated information at:

[bmw-motorrad.com](http://bmw-motorrad.com)

## Principle Operating elements

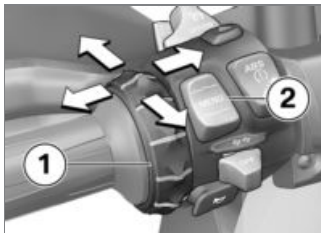

All contents of the display are controlled by the Multi-Controller **1** and the rocker button **MENU 2**.

The following functions are possible depending on the context.

### Functions of the Multi-Controller

#### Turn the Multi-Controller up:

- Move cursor up in lists.
- Make settings.
- Increase volume.

#### Turn the Multi-Controller down:

- Move cursor down in lists.
- Make settings.
- Reduce volume.

#### Tilt Multi-Controller to the left:

- Activate the function according to the operating feedback.
- Activate function to the left or back.
- After settings, return to menu view.
- In the menu view: move up one hierarchy level.
- In the My Vehicle menu: leaf to the next menu sheet.

#### Tilt Multi-Controller to the right:

- Activate the function according to the operating feedback.
- Confirm selection.
- Confirm settings.
- Leaf to the next menu step.

- Scroll to right in lists.
- In the My Vehicle menu: leaf to the next menu sheet.

## Rocker button MENU functions

### NOTICE

Navigation instructions are displayed as a dialog if the Navigation menu has not been called up. Operation of the MENU rocker button is temporarily restricted.◀

### Briefly press the MENU up:

- In the menu view: move up one hierarchy level.
- In the Pure Ride view: change display for rider info status line.

### MENU long press up:

- In the menu view: open Pure Ride view.

- In the Pure Ride view: change the operating focus to the navigator.

### MENU short press down:

- Change a hierarchy level down.
- No function when lowest hierarchy level is reached.

### MENU long press down:

- Return to the last menu, after a menu change has been previously carried out by long press of the rocker button MENU at the top.

## Operating instructions in the main menu

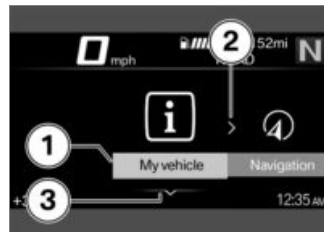

The operating instructions indicate whether and which interactions are possible.

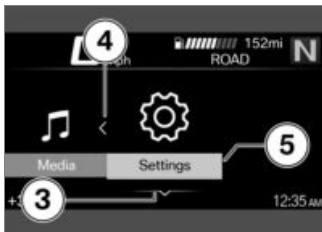

### Meaning of the operating instructions:

- Operating instruction **1**: the left end has been reached.
- Operating instruction **2**: you can leaf to the right.
- Operating instruction **3**: you can leaf down.
- Operating instruction **4**: you can leaf to the left.
- Operating instruction **5**: the right end has been reached.

### Operating instructions in submenus

In addition to the operating instructions in the main menu, there are additional operating instructions in submenus.

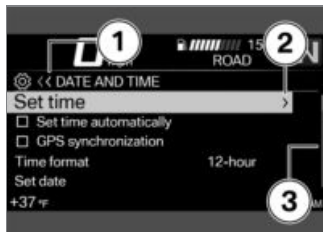

### Meaning of the operating instructions:

- Operating instruction **1**: the current display is in a hierarchical menu. One symbol indicates a submenu level. Two symbols indicate two or more submenu levels. The color of the symbol changes depending

on whether it is possible to return to the top.

- Operating instruction **2**: another submenu level can be called up.
- Operating instruction **3**: there are more entries than can be displayed.

### Show Pure Ride view

- Long-press the top rocker button MENU.

## Switching functions on and off

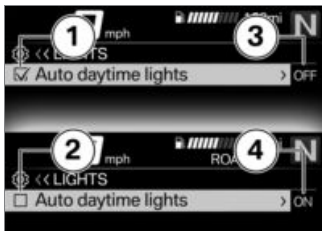

Some items are preceded by a box. The box indicates whether the function is switched on or off. Action symbols after the menu items illustrate what is switched by briefly tilting the Multi-Controller to the right.

### Examples for switching on and off:

- Symbol **1** indicates that the function is switched on.
- Symbol **2** indicates that the function is switched off.

- Symbol **3** indicates that the function can be switched off.
- Symbol **4** indicates that the function can be switched on.

## Calling up the menu

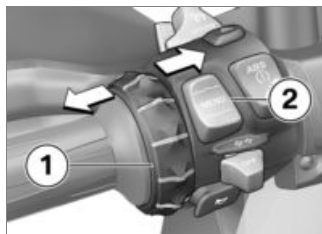

- Show Pure Ride view (▬▬▬▬ 113).
- Briefly press button **2** downward.

The following menus can be called up:

- My vehicle
- Navigation
- Media
- Telephone
- Settings

- Press Multi-Controller **1** repeatedly briefly to the right until the desired menu item is marked.
- Briefly press button **2** downward.



### NOTICE

The Settings menu can only be called up when stationary. ◀

## Moving the cursor in lists

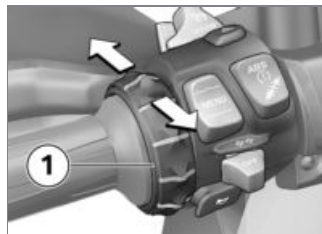

- Calling up the menu (▬▬▬▬ 114).
- To move the cursor down in lists, turn the Multi-Controller **1**

down until the desired entry is marked.

- To move the cursor up in lists, turn the Multi-Controller **1** up until the desired entry is marked.

## Confirming the selection



- Select desired entry.
- Multi-Controller **1** short press to right.

## Calling up the last menu used

- In the Pure Ride view: rocker button MENU long press down.

- » The last used menu is called up. The last marked entry is selected.

## Operating focus change

- with preparation for navigation system<sup>OE</sup>

When the Navigator is connected, you can switch between the operation of the Navigator and the TFT display.

## Changing the operating focus

- with preparation for navigation system<sup>OE</sup>

- Securely fasten navigation device (➡ 222).
- Show Pure Ride view (➡ 113).
- Press and hold the top MENU rocker button.
  - » Operating focus changes to the Navigator or the TFT display. The active device is marked in the upper left status line.

Operating actions affect the active device until the operating focus is changed again.

- » Operating the navigation system (➡ 224)

## System status displays

The system status is displayed in the lower menu area when a function has been switched on or off.

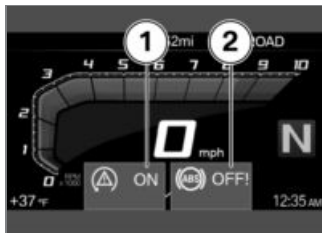

## Examples of the meaning of the system statuses:

- System status **1**: ASC/DTC function is switched on.

- System status **2**: ABS function is switched off.

## Changing the display for rider info. status line

### Requirement

The vehicle is at a standstill. The Pure Ride view is displayed.









- Switching on ignition (►► 74).
  - » In the TFT display, all information necessary for operation on public roads is provided by the onboard computer. The information can be displayed in the upper status line.
- with tire pressure monitor (TPM)<sup>OE</sup>
  - » In addition, information from the tire pressure control can be displayed.◀
- Select content of driver info. status line (►► 116).



- Press and hold button **1** to display the Pure Ride view.
- Press button **1** briefly to select the value in the upper status line **2**.

The following values can be displayed:

- Odometer Total
- Trip distance 1 Current
- Trip distance 2 Current
- Average consumption 1
- Average consumption 2

-  Driving time 1
-  Driving time 2
-  Break 1
-  Break 2
-  Average speed 1
-  Average speed 2
-  Fuel gage
-  Range

### Select content of driver info. status line

- Call up menu Settings, Display, Status line content.

- Turn on desired displays.
- » It is possible to change between the selected displays in the driver info. status line. If no displays are selected, only the range is shown.

## Making settings



- Select desired settings menu and confirm.
- Turn Multi-Controller **1** down until the desired setting is marked.
- If an operating instruction is present, tilt Multi-Controller **1** to the right.

- If no operating instruction is present, tilt Multi-Controller **1** to the left.
- » The setting is saved.

## Switch Speed Limit Info on or off

### Requirement

Vehicle is connected to a compatible mobile terminal. The BMW Motorrad Connected app is installed on the mobile terminal.

- Speed Limit Info displays the currently permitted top speed.
- Call up menu *Settings, Display.*
- Switch Speed Limit Info on or off.

## Pure Ride view

### Tachometer

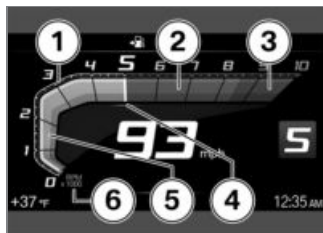

- 1 Scale
- 2 Low engine speed range
- 3 High / red engine speed range
- 4 Needle
- 5 Drag pointer
- 6 Unit for tachometer: 1000 RPM

## Range



The range **1** indicates how far you can ride with the remaining fuel. This distance is calculated on the basis of average consumption and the quantity of fuel on board.

- When the motorcycle is propped on its side stand the slight angle of inclination means that the sensor cannot register the fuel level correctly. For this reason, the range is only recalculated when the side stand is folded in.

- The range is displayed together with a warning once the fuel reserve is reached.
- After refueling, the range is recalculated if the fuel quantity is greater than the fuel reserve.
- The calculated range is only an approximate figure.

## Upshift recommendation



Upshift recommendation **1** signals the economically best point in time for upshifting.

## General settings

### Adjusting the volume

- Connect the rider's helmet and the passenger helmet (►► 121).
- Increase volume: turn Multi-Controller up.
- Reduce volume: turn Multi-Controller down.
- Mute: turn Multi-Controller all the way down.

### Set date

- Switching on ignition (►► 74).
- Call up menu **Settings**, **System settings**, **Date and time**, **Set date**.
- Set Day, Month, and Year.
- Confirm setting.

### Adjust date format

- Call up menu **Settings**, **System settings**, **Date and time**, **Date format**.
- Select desired setting.
- Confirm setting.

## Set clock

- Switching on ignition (▣▣▣▣ 74).
- Call up menu **Settings, System settings, Date and time, Set time.**
- Set **Hour** and **Minute.**

## Adjust time format

- Call up menu **Settings, System settings, Date and time, Time format.**
- Select desired setting.
- Confirm setting.

## Switch GPS synchronization on or off

- with preparation for navigation system<sup>OE</sup>
- Call up menu **Settings, System settings, Date and time.**
- Turn **GPS synchronization on or off.**
- » When the corresponding option is activated in the Navigator,

the time is taken from the Navigator.

» Special functions (▣▣▣▣ 226)

## Adjust units of measurement

- Call up menu **Settings, System settings, Units.**

The following units of measurement can be set:

- Distance covered
- Pressure
- Temperature
- Consumption

## Adjust language

- Call up menu **Settings, System settings, Language.**

The following languages can be set:

- Chinese
- German
- English
- Spanish
- French

- Italian
- Dutch
- Portuguese
- Russian
- Ukrainian

## Adjusting brightness

- Call up menu **Settings, Display, Brightness.**
- Adjust brightness.

## Reset all settings

- All settings in the **Settings** menu can be reset to the factory settings.
  - Call up menu **Settings.**
  - Select **Reset all** and confirm.
- The settings of the following menus are reset:
- Vehicle settings
  - System settings
  - Connections
  - Display
  - Information

» Existing Bluetooth connections are not deleted.

## Bluetooth

### Short-range radio technology

The Bluetooth function may not be offered depending on the country of use.

Bluetooth is a short-range wireless technology. Bluetooth devices are short-range devices (transmitting with a limited range) on the license-free ISM band (Industrial, Scientific, Medical) between 2.402 GHz and 2.480 GHz. They can be operated anywhere in the world without a license being required. Although Bluetooth is designed for establishing robust connections over short distances, faults are possible as with any other wireless technology. Connections can be subject to interference,

can be briefly interrupted or lost entirely. Especially when several devices are operated in one Bluetooth network, there is no guarantee for smooth operation in every situation.

#### Possible sources of interference:

- Interference fields due to transmission towers and similar.
- Devices with incorrectly implemented Bluetooth radio standard.
- By nearby Bluetooth-capable devices.

#### Pairing

Before two Bluetooth devices can be linked to one another, they must recognize each other. This process of mutual recognition is known as pairing. When two devices have paired they remember each other, so the pair-

ing process is conducted only once, on initial contact.



#### NOTICE

On some mobile devices, e.g. with operating system iOS, the BMW Motorrad Connected App must be called up before using. ◀

During the pairing process, the TFT display searches for other Bluetooth-compatible devices within its reception range. The conditions that have to be satisfied before the audio system can recognize another device are as follows:

- The Bluetooth function of the device must be activated
- The device must be "visible" to others
- The device must support the A2DP profile
- Other Bluetooth-capable devices must be OFF (e.g. mo-

bile phones and navigation systems).

Please consult the operating instructions for your communication system.

## Perform pairing

- Call up **Settings**, **Connections** menu.
- » In the **CONNECTIONS** menu, Bluetooth connections can be established, managed and deleted. The following Bluetooth connections are displayed:
  - Mobile device
  - Rider's helmet
  - Passeng. helmet

The connection status for mobile end devices is displayed.

## Connect mobile end device

- Perform pairing (▶▶▶ 121).

- Activate the Bluetooth function of the mobile end device (see operating instructions for the mobile end device).
- Select **Mobile device** and confirm.
- Select **PAIR NEW MOBILE DEVICE** and confirm.

Mobile end devices are searched for.



During the pairing, the Bluetooth symbol flashes in the lower status line.

Visible mobile end devices are displayed.

- Select the mobile end device and confirm.
- Observe the instructions for the mobile end device.
- Confirm that the codes match.
- » The connection is established and the connection status is updated.

- » If the connection cannot be established, the troubleshooting chart in the "Technical data" chapter may provide assistance. (▶▶▶ 237)
- » Depending on the mobile end device, telephone data is transferred to the vehicle automatically.
- » Telephone data (▶▶▶ 130)
- » If the phone book is not displayed, the troubleshooting chart in the "Technical data" chapter may provide assistance. (▶▶▶ 238)
- » If the Bluetooth connection does not work as expected, the troubleshooting chart in the "Technical data" chapter may provide assistance. (▶▶▶ 237)

## Connect the rider's helmet and the passenger helmet

- Perform pairing (▶▶▶ 121).

- Select Rider's helmet or Passeng. helmet and confirm.
- Show the communication system of the helmet.
- Select PAIR NEW RIDER'S HELMET or PAIR NEW PASS. HELMET and confirm.

Helmets are searched for.



During the pairing, the Bluetooth symbol flashes in the lower status line.

Visible helmets are displayed.

- Select helmet and confirm.
- » The connection is established and the connection status is updated.
- » If the connection cannot be established, the troubleshooting chart in the "Technical data" chapter may provide assistance. (▶▶▶ 237)
- » If the Bluetooth connection does not work as expected,

the troubleshooting chart in the "Technical data" chapter may provide assistance. (▶▶▶ 237)

## Delete connections

- Call up Settings, , Connections menu.
- Select Delete connections.
- To delete an individual connection, select the connection and confirm.
- To delete all connections, select Delete all connections and confirm.

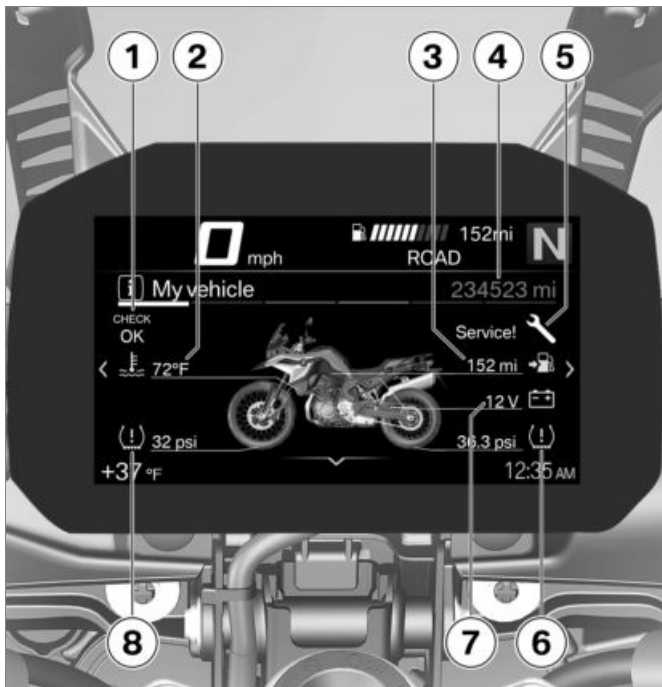

## My vehicle

### Start screen

- 1 Check Control display Layout (➡ 49)
- 2 Coolant temperature (➡ 62)
- 3 Range (➡ 118)
- 4 Total mileage
- 5 Service display (➡ 71)
- 6 Rear tire pressure (➡ 187)
- 7 Vehicle voltage (➡ 205)
- 8 Front tire pressure (➡ 187)

## Operating instructions

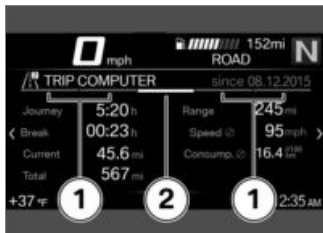

- Operating instruction **1**: tab that shows how far to the left or right you can leaf.
- Operating instruction **2**: tab that shows the position of the current menu screen.

## Scroll through menu windows

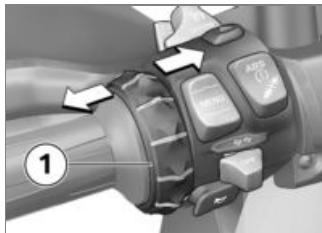

- Call up **My vehicle** menu.
- To scroll to the right, briefly push the Multi-Controller **1** to the right.
- To scroll to the left, briefly push the Multi-Controller **1** to the left.

The "My vehicle" menu contains the following windows:

- **MY VEHICLE**
- **CC messages** (if available)
- **ONBOARD COMPUTER**
- **TRIP COMPUTER**

- with tire pressure monitor (TPM)<sup>OE</sup>
- **TIRE PRESSURE**◀
- **SERVICE REQUIREMENTS**
- Further information on the tire pressure and CC messages can be found in the section "Displays".



### NOTICE

Check Control messages are dynamically added as additional tabs to the menu screens in the My Vehicle menu.◀

### On-board computer and travel on-board computer

The **ONBOARD COMPUTER** and **TRIP COMPUTER** menu panels show the vehicle and journey data, e.g. average values.

## Service display

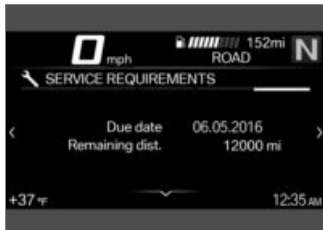

If the time remaining until the next service is less than a month, or if the next service is due within 700 miles (1000 km), a white CC message is displayed.

## On-board computer

### Calling up the on-board computer

- Call up the `My vehicle` menu.
- Scroll to the right until the `ON-BOARD COMPUTER` menu panel is displayed.

### Resetting the on-board computer

- Calling up the on-board computer (▣▣▣ 126).
- Press `MENU` rocker button down.
- Select `Reset all values` or `Reset individual values` and confirm.

The following values can be reset individually:

- `Break`
- `Journey`
- `Current (TRIP 1)`
- `∅ speed`
- `∅ consump.`

## Calling up the travel on-board computer

- Calling up the on-board computer (▣▣▣ 126).
- Scroll to the right until the `TRIP COMPUTER` menu panel is displayed.

### Resetting the travel on-board computer

- Calling up the travel on-board computer (▣▣▣ 126).
- Press `MENU` rocker button down.
- Select `Automatic reset` or `Reset all` and confirm.
- » If `Automatic reset` is selected, the travel on-board computer is automatically reset if at least 6 hours have passed since the ignition was switched off and the date has changed.

## Navigation

### Warnings



#### WARNING

### Operation of a smartphone while riding or with the engine running

Accident hazard

- Observe the relevant road traffic regulations.
- Do not use while riding (except for applications without operation such as telephony via the hands-free system).◀

## **WARNING**

### **Distraction from traffic conditions and loss of control**

Risk of accident through the use of integrated information systems and communication devices during the journey

- Operate these systems or devices only if the traffic situation allows.
- If necessary, stop and operate the system or devices at a standstill. ◀

### **Prerequisite**

The vehicle is connected to a compatible mobile end device.

The BMW Motorrad Connected App is installed on the mobile end device.

## **NOTICE**

On some mobile devices, e.g. with operating system iOS, the BMW Motorrad Connected App must be called up before using. ◀

### **Enter destination address**

- Connect mobile end device (▢▢▢ 121).
- Call up the BMW Motorrad Connected app and start the route guidance.
- Call up **Navigation** menu in the TFT display.
  - » Active route guidance is displayed.
  - » If the active route guidance is not displayed, the troubleshooting chart in the "Technical data" chapter may provide assistance. (▢▢▢ 238)

### **Select destination from most recent destinations**

- Call up **Navigation, Recent destinations** menu.
- Select destination and confirm.
- Select **Start route guidance**.

### **Select destination from favorites**

- The **FAVORITES** menu shows all destinations that have been saved as a favorite in the BMW Motorrad Connected app. It is not possible to create new favorites on the TFT display.
- Call up **Navigation, Favorites** menu.
- Select destination and confirm.
- Select **Start guidance**.

## Enter special destination

- Special destinations, e.g. landmarks, can be displayed on the map.
- Call up Navigation, POIs menu.

The following locations can be selected:

- At current location
- At destination
- Along the route
- Select the area to look for special destinations.

E.g. the following special destination can be selected:

- Filling station
- Select special destination and confirm.
- Select Start route guidance and confirm.

## Define route criteria

- Call up Navigation, Route criteria menu.

The following criteria can be selected:

- Route type
- Avoid
- Select desired Route type.
- Switch desired Avoid on or off.

The number of enabled avoidances is displayed in brackets.

## End route guidance

- Call up Navigation, Active route guidance menu.
- Select End route guidance and confirm.

## Switch spoken directions on or off

- Connect the rider's helmet and the passenger helmet (121).
- The navigation can be read out by a computer voice. To do this, the Spoken instructions must be switched on.

- Call up Navigation, Active route guidance menu.
- Switch Spoken instructions on or off.

## Repeat last spoken directions

- Call up Navigation, Active route guidance menu.
- Select Current spoken instruct. and confirm.

## Media

### Prerequisite

The vehicle is connected to a compatible mobile end device and a compatible helmet.

## Control music playback

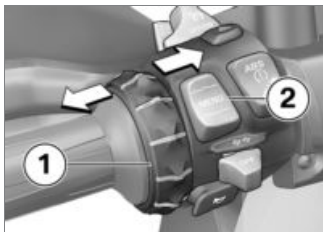

- Call up menu *Media*.

### NOTICE

BMW Motorrad recommends setting the volume for media and conversations via mobile end devices to the maximum before starting a journey. ◀

- Adjusting the volume (▮▶ 118).
- Next title: Tilt the Multi-Controller **1** briefly to the right.
- Last title or start of current title: Tilt the Multi-Controller **1** briefly to the left.

- Fast forward: Tilt and hold the Multi-Controller **1** to the right.
- Fast rewind: Tilt and hold the Multi-Controller **1** to the left.
- Call up context menu: Press button **2** down.

### NOTICE

Depending on the mobile end device, the scope of the Connectivity functions may be limited. ◀

- » The following functions can be used in the context menu:
  - Start playback or Pause playback.
  - For search and playback, select the category *Now playing*, *All artists*, *All albums* or *All tracks*.
  - Select *Playlists*.

In the submenu *Audio options*, you can adjust the following settings:

- Switch *Shuffle* on or off.

- Select *Repeat*: *Off*, *One* (current title) or *All*.

## Phone

### Prerequisite

The vehicle is connected to a compatible mobile end device and a compatible helmet.

### Make a phone call

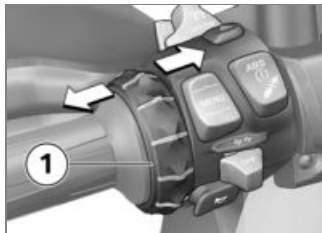

- Call up menu *Telephone*.
- Accept telephone call: Tilt the Multi-Controller **1** to the right.
- Reject telephone call: Tilt the Multi-Controller **1** to the left.

- End telephone call: Tilt the Multi-Controller **1** to the left.

## Muting

The microphone in the helmet can be muted during active conversations.

## Conversations with multiple users

A second telephone call can be accepted during a conversation. The first conversation will be put on hold. The number of active telephone calls is displayed in the Telephone menu. It is possible to switch between two conversations.

## Telephone data

Depending on the mobile end device, telephone data is transferred to the vehicle automatically after pairing (►► 120).

**Phone book:** List of contacts saved in the mobile end device

**Call list:** List of telephone calls with the mobile end device

**Favorites:** List of favorites saved in the mobile end device

## Display software version

- Call up menu Settings, Information, Software version.

## Display license information

- Call up menu Settings, Information, Licenses.

## **Alarm system**

Overview .....	132
Activation .....	132
Alarm function .....	134
Deactivation .....	135
Programming .....	135

## Overview

- with anti-theft alarm system (DWA)<sup>OE</sup>

## General information on DWA

Any attempt to move the vehicle, change its location, start it without authorization or remove its battery will trigger the alarm. The system is designed not to be so sensitive that minor vibrations on the vehicle would trigger the alarm. Any attempted theft is signaled acoustically by means of the siren and visually by means of the synchronous flashing of all four indicator lights upon activation of the system.

You can adapt the behavior of your DWA in subsections as desired.

## Conservation of the vehicle battery

To conserve the vehicle battery and maintain the starting capability, the activated DWA switches off after a number of days. It remains active, however, for at least 30 days.

## Activation

- with anti-theft alarm system (DWA)<sup>OE</sup>

## Activation

- Switching on ignition (➡ 74).
- Adjust anti-theft alarm system (➡ 133).
- Turn off ignition.
  - » If DWA is activated, DWA is automatically activated after the ignition is switched off.
  - » Activation takes approximately 30 seconds to complete.
  - » Turn indicators are illuminated twice.

- » Confirmation tone sounds twice (if programmed).
- » The anti-theft alarm system is active.

## Activation with Keyless Ride

- with Keyless Ride<sup>OE</sup>

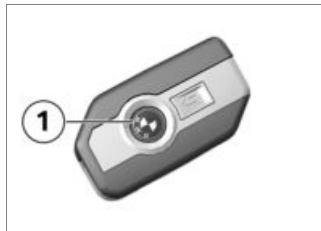

- Turn off ignition.
- Press button **1** on the radio-operated key.
  - » Activation takes approximately 30 seconds to complete.
  - » Turn indicators are illuminated twice.

- » Confirmation tone sounds twice (if programmed).
- » The anti-theft alarm system is active.

## Motion sensor when transporting the motorcycle

If, for example, the motorcycle is to be transported by train, it is advisable to switch off the motion sensor. The strong movements could result in an accidental triggering of the alarm.

## Deactivate motion sensor

– with Keyless Ride<sup>OE</sup>

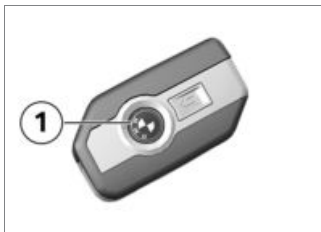

- Press button **1** on the radio-operated key again during the activation phase.
  - » Turn signals are illuminated three times.
  - » Confirmation tone sounds three times (if programmed).
  - » Movement sensor is deactivated.

## Adjust anti-theft alarm system

- Switching on ignition (➡ 74).
- Select SETUP (➡ 85).
- Press MENU rocker button up **1** briefly and repeatedly un-

til SETUP DWA appears on the display.



- Press MENU rocker button down **2** briefly to switch between DWA ON **3** and DWA OFF.

The following settings are available:

- DWA ON: DWA is activated or is automatically activated after the ignition is switched off.
- DWA OFF: DWA is deactivated.
- Press and hold MENU rocker button up **1** to exit SETUP.



## Reason for triggering of the alarm

After the alarm function has been deactivated, the DWA LED indicates the reason for any alarm activation which may have occurred for one minute:

- 1 flash: motion sensor 1
- 2 flashes: motion sensor 2
- 3 flashes: ignition turned on with unauthorized ignition key
- 4 flashes: alarm system disconnected from vehicle battery
- 5 flashes: motion sensor 3

## Deactivation

- with anti-theft alarm system (DWA)<sup>OE</sup>

## Deactivate the alarm function

- Switch on the ignition with an authorized vehicle key.

- with Keyless Ride<sup>OE</sup>

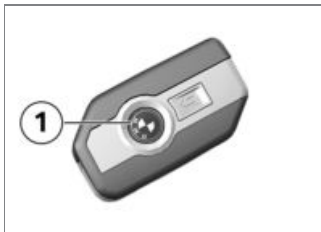

- Press button **1** on the radio-operated key once.

### NOTICE

If the alarm function is deactivated using the radio-operated key and the ignition is not then switched on, it will reactivate automatically after 30 seconds if "activation after ignition off" is programmed.◀

- » Turn indicators light up once.
- » Alarm tone sounds once (if programmed).
- » Alarm function is deactivated.

## Programming

- with anti-theft alarm system (DWA)<sup>OE</sup>

## Programming options

Your BMW Motorrad partner can adapt the anti-theft alarm system in the following areas to meet individual requirements:

- Confirmation alarm tone after activating/deactivating the DWA in addition to the turn signals lighting up.
- Rising and falling or intermittent alarm tone.

- with Connectivity<sup>OE</sup>

The anti-theft alarm system can be adapted in the menu `Settings, Vehicle settings, Alarm system`.

## Factory settings

The anti-theft alarm system is delivered with the following factory settings:

- Confirmation alarm tone after activation/deactivation of the DWA: no.
- Alarm tone: rising.

## Setting

Mirrors .....	138
Headlight .....	138
Clutch .....	139
Brakes .....	140
Spring preload .....	140
Damping .....	141

## Mirrors

### Adjusting mirrors



- Move mirror into desired position by twisting.

### Adjusting mirror arm



- Slide protective cap **1** up over screw connection on mirror arm.
- Loosen nut **2**.
- Turn mirror arm into desired position.
- Tighten nut to specified torque while holding mirror arm in place.



Mirror (locknut) on clamping piece

16 lb/ft (22 Nm) (Left-hand thread)

- Slide protective cap over threaded fastener.

## Headlight

### Headlight setting for right-hand/left-hand traffic

In countries where you must drive on the opposite side of the road from the country in which the vehicle was registered, the asymmetrical low-beam headlight dazzles oncoming traffic.

Have the headlights adapted to the relevant conditions by a specialist workshop, preferably by a BMW Motorrad retailer.

### Headlight range and spring preload

The headlight range generally remains constant due to the adjustment of the spring preload to the loading state.

Only with a very heavy payload can adjustment of the spring preload be insufficient. If that is the case, the headlight range must be adapted to the weight.



## NOTICE

If there are doubts as to the correct headlight range, have the adjustment checked by a specialized workshop, preferably by an authorized BMW Motorrad retailer. ◀

## Headlight range adjustment



- Remove screws **1** on left and right.
- Adjust the headlights by tilting them slightly.
- Tighten the screws **1** on the left and right.

## Clutch

### Adjusting clutch lever



## WARNING

### Adjusting the clutch lever while driving

Accident hazard

- Adjust the clutch lever when the motorcycle is stationary. ◀



- Turn the adjusting screw **1** clockwise to increase distance between clutch lever and handlebar grip.
- Turn the adjusting screw **1** counterclockwise to decrease distance between clutch lever and handlebar grip.



## NOTICE

The adjusting screw is easier to turn when the clutch lever is pressed forward. ◀

## Brakes

### Adjusting brake lever

#### WARNING

#### Modified position of the brake fluid reservoir

Air in the brake system

- Do not twist the handlebar fitting or the handlebars. ◀

#### WARNING

#### Adjusting the brake lever while driving

Accident hazard

- Only adjust the brake lever when the motorcycle is stationary. ◀

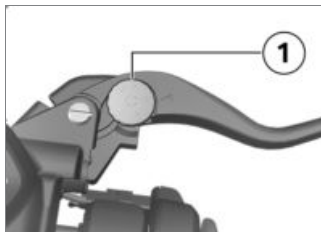

- Turn the adjusting screw **1** counterclockwise to increase the distance between the brake lever and handlebar grip.
- Turn the adjusting screw **1** clockwise to decrease the distance between the brake lever and handlebar grip.



#### NOTICE

The adjusting screw is easier to turn if you push the brake lever forwards. ◀

## Spring preload

### Setting

It is essential to set the spring preload to suit the load carried by the motorcycle. Increase spring preload when the vehicle is heavily loaded and reduce spring preload accordingly when the vehicle is lightly loaded.

#### Adjusting the spring preload on the rear wheel

- Removing seat (▶▶ 106).
- Remove toolkit.

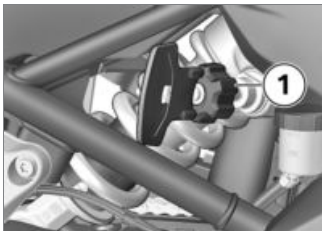

## **WARNING**

### **Uncoordinated settings of spring preload and spring strut damping.**

Poorer handling.

- Adjust damping characteristic to changed spring preload. ◀
- To increase spring preload, turn adjustment wheel **1** clockwise using toolkit.
- To decrease spring preload, turn adjustment wheel **1** counterclockwise using toolkit.



Basic setting of spring preload, rear

– without Dynamic ESA<sup>OE</sup>

Turn adjustment wheel counterclockwise as far as possible. (One-up without load)

Turn adjuster wheel counterclockwise as far as possible, then 20 turns clockwise. (One-up with load)

Turn adjustment wheel clockwise as far as possible. (Two-up and load) ◀

- Remount toolkit.
- Installing seat (▶▶▶ 107).

## **Damping Setting**

Damping must be adjusted to the road conditions and the spring preload.

- A rough road surface requires softer damping than a smooth road surface.
- An increase in spring preload requires firmer damping, a reduction in spring preload requires softer damping.

### **Adjusting the damping characteristic for rear wheel**

- Park motorcycle on a level, firm surface.



- Adjust damping via the adjusting screw **1**.

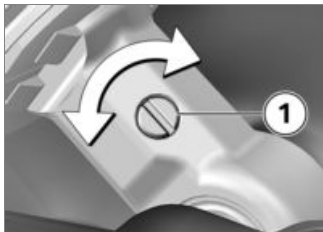

- To increase damping, turn the adjusting screw **1** clockwise.
- To reduce damping, turn the adjusting screw **1** counter-clockwise.

 Basic setting of rear wheel damping

– without Dynamic ESA<sup>OE</sup>

Turn adjusting screw clockwise up to the stop, then turn back by 1.5 turns. (One-up without load)

 Basic setting of rear wheel damping

Turn adjusting screw clockwise up to the stop, then turn back by 0.5 turns. (One-up with load)

Turn adjusting screw clockwise as far as possible, then back a quarter turn. (Two-up with load)◀

## Riding

Safety information .....	144
Observe checklist.....	147
If there is a change in the load status: .....	147
Before every journey: .....	147
At every third refueling stop: .....	147
Starting .....	147
Running in .....	151
Shifting gears .....	152
Off-road riding .....	153
Brakes .....	154
Parking your motorcycle .....	156
Refueling .....	156
Securing motorcycle for transport .....	161

## Safety information

### Rider's Equipment

The following clothing provides protection for you when driving:

- Helmet
- Rider's suit
- Gloves
- Boots

This applies even to short journeys, and to every season of the year. Your authorized BMW Motorrad retailer will be happy to advise you and has the correct clothing for every purpose.

### Reduced clearance in inclined position

- with lowered<sup>OE</sup>

Motorcycles with lowered running gear have a reduced clearance in inclined position and to the ground compared to motorcycles

with standard running gear (see the chapter "Technical Data").



### WARNING

**When cornering with lowered motorcycles, motorcycle parts can contact the road surface sooner than normal.**

Accident hazard

- Carefully test the clearance of the motorcycle in an inclined position and adjust your riding style accordingly.◀

Test the clearance of your motorcycle at an angle in safe situations. Remember to take the limited ground clearance of your motorcycle into account when driving over curbs and similar obstacles.

Lowering the motorcycle reduces the spring travel. A possible reduction in the accustomed driving comfort may result. Especially when riding with a passen-

ger, the spring preload should be adjusted accordingly.

### Correct loading



### WARNING

**Reduced riding stability caused by overloading and uneven loading**

Accident hazard

- Do not exceed the gross weight limit and observe the loading information.◀
- Adjust the spring preload and damping for the current gross vehicle weight.
  - with case<sup>OA</sup>
- Ensure that case volumes on left and right are equal.
- Make sure that weight is uniformly distributed between right and left.
- Pack heavy pieces of luggage to bottom and inside of cases.

- Observe the maximum payload and maximum speed according to the sign in the case (also see Chapter "Accessories").

 Payload per case
max 18 lbs (max 8 kg)◀

– with topcase<sup>OA</sup>

- Observe the maximum payload and maximum speed according to the sign in the topcase (also see Chapter "Accessories").

 Payload of Topcase
max 11 lbs (max 5 kg)◀

– with tank bag<sup>OA</sup>

- Observe the maximum payload of the tank bag (see also "Accessories" chapter).

 Payload of tank rucksack
max 11 lbs (max 5 kg)◀

– with rear bag<sup>OA</sup>

- Observe the maximum payload of the rear bag (see also "Accessories" chapter).

 Payload of rear bag
max 3 lbs (max 1.5 kg)◀

## Speed

If you ride at high speed, always bear in mind that various boundary conditions can adversely affect the handling of your motorcycle, e.g.:

- Incorrect settings of spring-strut and shock absorber system
- Imbalanced load
- Loose clothing

- Insufficient tire inflation pressure
- Poor tire tread
- Installed luggage systems, such as cases, topcases and tank rucksacks.

## Maximum speed with studded or winter tires



**Maximum speed of the motorcycle is higher than the permissible maximum rated speed of the tires.**

Risk of accident due to tire damage at high speed.

- Observe the maximum permissible speed for the tyres.◀

With studded or winter tires, the maximum permissible speed for the tires must be observed. Attach a label specifying the maximum permissible speed in

the field of view of the instrument cluster.

## Risk of poisoning

Exhaust fumes contain carbon monoxide, which is colorless and odorless but highly toxic.



### WARNING

## Harmful exhaust gas

Danger of suffocation

- Do not inhale exhaust fumes.
- Do not run the engine in closed rooms. ◀

## Burn hazard



### CAUTION

## Intense heating up of engine and exhaust system while riding

Burn hazard

- After parking the motorcycle, make sure that no persons or objects come into contact

with the engine and exhaust system. ◀

## Catalytic converter

If misfiring causes unburned fuel to enter the catalytic converter, there is a danger of overheating and damage.

For this reason, observe the following points:

- Do not run the fuel tank dry
- Do not run the engine with the spark-plug cap removed
- Stop the engine immediately if it misfires
- Use unleaded fuel only
- Comply with all specified maintenance intervals.



### ATTENTION

## Unburned fuel in the catalytic converter

Damage to catalytic converter

- Note the points listed for protection of the catalytic converter. ◀

## Danger of overheating



### ATTENTION

## Engine idling for a lengthy period while at a standstill

Overheating due to insufficient cooling; in extreme cases vehicle fire

- Do not allow the engine to idle unnecessarily.
- After starting, ride off immediately. ◀

## Modifications



### ATTENTION

## Modifications to the motorcycle (e.g. engine control unit, throttle valves, clutch)

Damage to the affected parts, failure of safety-relevant functions, expiration of warranty

- Do not make any modifications. ◀

## Observe checklist

- Use the following checklist to check your motorcycle at regular intervals.

## If there is a change in the load status:

- without Dynamic ESA<sup>OE</sup>
- Adjusting the spring preload on the rear wheel (▮▮▮ 140).
- Adjusting the damping characteristic for rear wheel (▮▮▮ 141). ◀
- with Dynamic ESA<sup>OE</sup>
- Setting suspension compliance (▮▮▮ 94). ◀

## Before every journey:

- Check operation of the brake system.
- Check operation of the lighting and signal system.
- Checking clutch function (▮▮▮ 184).
- Check tire tread depth (▮▮▮ 188).
- Checking the tire pressure (▮▮▮ 187).
- Check secure hold of cases and luggage.

## At every third refueling stop:

- Checking engine oil level (▮▮▮ 178).
- Checking the front brake pad thickness (▮▮▮ 181).
- Checking the rear brake pad thickness (▮▮▮ 181).
- Checking the front brake fluid level (▮▮▮ 182).

- Checking the rear brake fluid level (▮▮▮ 183).
- Checking coolant level (▮▮▮ 186).
- Lubricating chain (▮▮▮ 210).
- Checking chain sag (▮▮▮ 210).

## Starting

### Starting the engine



#### ATTENTION

### Sufficient transmission gearbox lubrication only when the engine is running.

Transmission damage

- Do not allow the motorcycle to roll for longer periods or push it over longer distances with the engine switched off. ◀
- Switching on ignition (▮▮▮ 74).
  - » Pre-Ride-Check is carried out. (▮▮▮ 148)
  - » ABS self-diagnosis is performed. (▮▮▮ 149)

- » ASC self-diagnosis is performed. (➡ 149)
- with riding modes Pro<sup>OE</sup>
- » DTC self-diagnosis is performed. (➡ 150)◀
- Engage neutral, or pull back clutch lever if a gear is engaged.

### NOTICE

You cannot start the motorcycle with the side stand extended and a gear engaged. The engine will switch itself off if it is started with the transmission in neutral and then a gear is engaged before retracting the side stand.◀



- Press starter button **1**.

### NOTICE

The starting attempt is automatically interrupted if battery voltage is too low. Recharge the battery before you attempt to start the engine again, or use jumper cables and a donor battery to start. More detailed information can be found in the "Maintenance" chapter under "Jump-starting".◀



Engine starts.

- » If the engine fails to start, the troubleshooting chart in chapter "Technical Data" may provide assistance. (➡ 236)

## Pre-Ride-Check

After switching on the ignition, the instrument cluster performs a test of the indicator and warning lights – the so-called "Pre-Ride-Check". Starting the engine before the test routine is completed will cancel the remainder of the routine.

### Phase 1

All indicator and warning lights are switched on. After a longer standstill of the vehicle, an animation is displayed during the system start.

### Phase 2

The general warning light switches from red to yellow.

### Phase 3

All switched on indicator and warning lights are switched off one after the other in reverse order.

If one of the indicator and warning lights does not switch on:

- Have the malfunction corrected as soon as possible at an authorized specialist workshop, preferably an authorized BMW Motorrad retailer.

### ABS self-diagnosis

The self-diagnosis routine is determining whether BMW Motorrad ABS is ready for operation. The self-diagnosis routine launches automatically when you switch on the ignition.

#### Phase 1

- » Check on system components monitored by diagnostic system while motorcycle is parked.



ABS indicator and warning lamp flashes.

#### Phase 2

- » Check wheel sensors while starting off.



ABS indicator and warning lamp flashes.

### ABS self-diagnosis completed

- » The ABS indicator and warning light goes out.



ABS self-diagnosis routine not completed

ABS is not available, as the self-diagnosis routine was not completed. (The motorcycle must reach a specified minimum speed before the system can check operation of the wheel speed sensors: 3 mph (5 km/h))

If an ABS error is displayed after the ABS self-diagnosis is completed:

- It remains possible to continue riding. It must be noted that the ABS function is not available.
- Have the malfunction corrected as soon as possible at an authorized service facility, preferably an authorized BMW Motorrad Retailer.

### ASC self-diagnosis

The self-diagnosis routine checks whether the BMW Motorrad ASC is ready for operation. The self-diagnosis routine runs automatically when you switch on the ignition.

#### Phase 1

- » Check on system components monitored by the diagnostic system while motorcycle is parked.



ASC indicator and warning light flashes slowly.

## Phase 2

» Checking the diagnosable system components while the motorcycle is moving.



ASC indicator and warning light flashes slowly.

## ASC self-diagnosis completed

- » The ASC indicator and warning light goes out.
- Check the display of all indicator and warning lights.



ASC self-diagnosis routine not completed

ASC is not available because the self-diagnosis routine was not completed. (The motorcycle must reach a specified minimum speed before the system can check operation of the wheel sensors: min 3 mph (min 5 km/h))

If an ASC error is indicated following completion of the ASC self-diagnosis routine:

- It remains possible to continue riding. It must be noted that the ASC function is not available.
- Have the malfunction corrected as soon as possible at an authorized service facility, preferably an authorized BMW Motorrad Retailer.

## DTC self-diagnosis

– with riding modes Pro<sup>OE</sup>

The self-diagnosis routine is determining whether BMW Motorrad DTC is ready for operation. The self-diagnosis routine runs automatically when you switch on the ignition.

### Phase 1

» Check on system components monitored by diagnostic system while motorcycle is parked.



DTC indicator and warning light flashes slowly.

### Phase 2

» Checks diagnosis-capable system components when motorcycle starts to move.



DTC indicator and warning light flashes slowly.

## DTC self-diagnosis completed

- » The DTC symbol is no longer displayed.
- Check the display of all indicator and warning lights.

 DTC self-diagnosis not completed

The DTC function is not available, as the self-diagnosis function has not been completed. (To check wheel speed sensors, motorcycle must reach a minimum speed with engine running: min 3 mph (min 5 km/h))

If an DTC error is displayed after the DTC self-diagnosis is completed:

- It remains possible to continue riding. It must be noted that the availability of the DTC function is restricted or it is not available at all.

- Have the malfunction corrected as soon as possible at an authorized service facility, preferably an authorized BMW Motorrad Retailer.

## Running in Engine

- In the period preceding the initial inspection attempt to change rpm and engine load as frequently as possible, avoiding extended periods at constant rpm.
- Try to do most of your riding during this initial period on twisting, fairly hilly roads, avoiding highways if possible.
- Observe the engine run-in speeds.

 Engine run-in speed

<6500 min<sup>-1</sup> (Mileage 0...746 miles (0...1200 km))



Engine run-in speed

No full throttle (Mileage 0...746 miles (0...1200 km))

- Observe mileage, after which the running-in check should be performed.



Mileage until first running-in check

311...746 miles (500...1200 km)

## Brake pads

New brake pads must be run in before they achieve their optimum friction force. This initial reduction in braking efficiency can be compensated for by exerting greater pressure on the brake levers.

## WARNING

### New brake pads

Extension of the braking distance, accident hazard

- Brake early.◀

### Tires

New tires have a smooth surface. This must be roughened by riding in a restrained manner at various lean angles until the tires are run in. This running in procedure is essential if the tires are to achieve maximum grip.

## WARNING

### Loss of adhesion of new tires on wet roads and at extreme angles

Accident hazard

- Always think well ahead and avoid extreme angles.◀

## Shifting gears

– with Gearshift Assistant Pro<sup>OE</sup>

### Shift assistant Pro

## NOTICE

When changing gear using the Pro Gear-shift Assistance function, the cruise-control system is automatically deactivated for safety reasons.◀

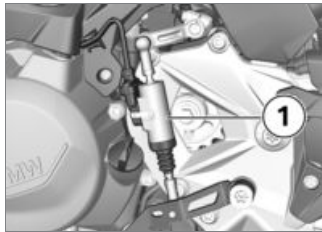

- Engage the gears as usual with the foot-operated gearshift lever.
- » The Gearshift Assistant provides assistance for upshifts

and downshifts, without the rider having to actuate the clutch or throttle grip.

- This is not an automatic-shift system.
- The rider is the most important part of the system and decides when to shift gears.
- The sensor **1** on the gearshift shaft detects the gearshift request and triggers the shift assistance.
- » When riding at a steady speed in a low gear at high engine rpm, an attempt to shift gear without pulling the clutch can cause a severe load-change reaction.
- BMW Motorrad recommends disengaging the clutch for shifts in these circumstances.
- Use of the Gearshift Assistant Pro should be avoided at engine speeds where the engine speed limiter becomes active.

- » Shift assistance is not available in the following situations:
  - With clutch actuated.
  - Shift lever not in its initial position.
  - When upshifting with closed throttle valve (coasting overrun) or when decelerating.
  - When downshifting with open throttle valve or when accelerating.
- After a gearshift, you must fully release the gearshift lever before another gear change with the Gearshift Assistant Pro can take place.
- » Further information on the Gearshift Assistant Pro can be found in the section "Technology in detail":
  - with riding modes Pro<sup>OE</sup>
  - » Pro gearshift assistant (➡ 172)◀

## Off-road riding

### After riding off-road

BMW Motorrad recommends the following after riding off-road:

### Tire pressure



#### WARNING

### When driving off-road, lower tire pressure than riding on paved roads

Risk of accident due to poorer handling characteristics.

- Ensure proper tire inflation pressure.◀

### Brakes



#### WARNING

### Riding on unpaved or dirty roads

Delayed braking effect due to dirty brake discs and brake pads

- Brake early until the brakes are clean again.◀



#### ATTENTION

### Riding on unpaved or dirty roads

Increased brake pad wear

- Check the brake pad thickness more often and replace the brake pads sooner.◀

### Spring preload and damping



#### WARNING

### Modified values for spring preload and spring strut damping when riding off-road

Poorer handling characteristics on paved roads

- Set correct spring preload and correct spring strut damping before leaving off-road terrain.◀

### Rims

BMW Motorrad recommends checking the rims for possible damage after riding off-road.

## Air cleaner element



### ATTENTION

#### Dirty air filter element

Engine damage

- When driving in dusty terrain, check air filter insert for soiling at short intervals and clean or replace if necessary. ◀

Use under very dusty conditions (deserts, savannas, etc.) requires the use of air filter elements specially developed for these kinds of applications.

## Brakes

### How do you achieve the shortest stopping distances?

The dynamic load distribution between the front and rear wheel changes during braking. The heavier you brake, the greater the weight transfer to the front wheel. Increases in the load on

an individual wheel are accompanied by a rise in the effective braking force that the wheel can provide.

To achieve the shortest possible braking distance, the front brake must be applied quickly and with progressively greater levels of force. This procedure provides ideal exploitation of the extra weight transfer to the front wheel. The clutch should also be disengaged at the same time. With the frequently instructed "forced braking," in which the brake pressure is generated as quickly as possible and with great force, dynamic load distribution lags behind the progressive increases in deceleration rate and the braking force cannot be completely transferred to the road surface. The front wheel can lock up.

Locking up of the front wheel is prevented by BMW Motorrad ABS.

## Descending mountain passes



### WARNING

#### Braking only with the rear-wheel brake when descending mountain passes

Reduced of braking action, destruction of the brakes caused by overheating

- Use both front and rear brakes, and make use of the engine's braking effect as well. ◀

#### Wet, soiled brakes

Moisture and dirt on the brake rotors and the brake pads result in a decrease in the braking action.

Delayed or poorer braking action must be expected in the following situations:

- When driving in the rain and through puddles.
- After washing the vehicle.
- When driving on roads spread with salt.
- After working on the brakes due to oil or grease residues.
- When driving on soiled roads or offroad.

### **WARNING**

#### **Poorer braking action due to moisture and dirt**

Accident hazard

- Brake until brakes are dry or clean; clean if necessary.
- Brake early until the full braking action is available again.◀

## **ABS Pro**

– with riding modes Pro<sup>OE</sup>

### **Physical riding limits**

#### **WARNING**

#### **Braking in curves**

Danger of falling despite ABS Pro

- The rider is always responsible for adapting his/her driving style.
- Do not reduce the system's extra safety margin with careless riding or unnecessary risks.◀

ABS Pro is available in all riding modes except for Enduro PRO.

#### **Falling cannot be excluded**

Although ABS Pro represents valuable support and an enormous safety advantage for the rider when braking in the inclined position, it by no means redefines the physical riding limits. It is still possible to exceed those

limits through misjudgments or riding errors. In extreme cases this may result in a fall.

### **Use on public roads**

ABS Pro helps make riding your motorcycle on public roads even safer. When braking due to unexpected hazards in curves, locking-up and slipping of the wheels is prevented within the scope of the physical riding limits.

#### **NOTICE**

ABS Pro was not developed to increase the individual braking performance in the inclined position.◀

## Parking your motorcycle

### Side stand

- Switch off engine.



#### ATTENTION

### Poor ground conditions in area of stand

Component damage cause by tipping over

- Always check that the ground under the stand is level and firm.◀



#### ATTENTION

### Loading of the side stand with additional weight

Component damage cause by tipping over

- Do not sit on the motorcycle when it is parked on the side stands.◀

- Fold out side stand and park motorcycle.
- If the slope of the road permits, turn the handlebars to the left.
- On slopes point the motorcycle uphill and engage 1st gear.

### Center stand

– with center stand<sup>OE</sup>

- Switch off engine.



#### ATTENTION

### Poor ground conditions in area of stand

Component damage cause by tipping over

- Always check that the ground under the stand is level and firm.◀



#### ATTENTION

**Center stand folds if subject to sharp movements.**

Component damage cause by tipping over

- Do not sit on the motorcycle while it is resting on the center stand.◀
- Fold out center stand and jack up motorcycle.

## Refueling

### Fuel grade

#### Requirement

For optimal fuel consumption, the fuel should be sulfur-free or very low in sulfur content.



#### ATTENTION

### Refueling with leaded fuel

Damage to catalytic converter

- Do not refuel with leaded gasoline or gasoline with metallic additives, e.g. manganese or iron.◀



## ATTENTION

### Use of Ethanol E85 as fuel

Damage to the engine and fuel supply

- Do not refuel with E85, i.e. fuel with an ethanol content of 85 %, or with Flex Fuel.◀
- Observe the maximum ethanol content of the fuel.



Recommended fuel quality

Regular unleaded (max. 15 % ethanol, E15)  
87 AKI (91 ROZ/RON)  
87 AKI

### Refueling procedure



## WARNING

### Fuel is highly flammable

Fire and explosion hazard

- Do not smoke. Never bring a naked flame near the fuel tank.◀



## WARNING

### Escaping of fuel due to expansion under exposure to heat with overfilled fuel tank

Accident hazard

- Do not overfill the fuel tank.◀



## ATTENTION

### Contact of fuel and plastic surfaces

Damage to surfaces (become unattractive or cloudy)

- Immediately clean plastic surfaces after contact with fuel.◀
- Put the motorcycle up on the side stand, ensuring that it is resting on a firm and level support surface.

– with center stand<sup>OE</sup>



## WARNING

### Fuel is highly flammable

Fire and explosion hazard

- Do not smoke. Never bring a naked flame near the fuel tank.◀



## WARNING

### Escaping of fuel due to expansion under exposure to heat with overfilled fuel tank

Accident hazard

- Do not overfill the fuel tank.◀



## ATTENTION

### Contact of fuel and plastic surfaces

Damage to surfaces (become unattractive or cloudy)

- Immediately clean plastic surfaces after contact with fuel.◀

- Put the motorcycle up on the center stand, ensuring that it is resting on a firm and level support surface.◀

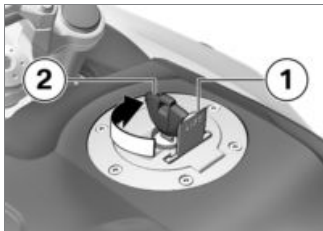

- Open the protective flap **1**.
- Unlock the fuel tank cap **2** with ignition key clockwise and fold up.



- Refuel up to the lower edge of the filler neck, but no higher.

**NOTICE**

If refueling is carried out after running on fuel reserve, the resulting filling capacity must be greater than the fuel reserve so that the new fill level is detected and the fuel reserve indicator light is switched off.◀

**NOTICE**

The "usable fuel quantity" specified in the technical data is the fuel quantity, which can be re-

fueled if the fuel tank was completely emptied, i.e., if the engine dies off due to lack of fuel.◀



Tank capacity

Approx. 4 gal (Approx. 15 l)



Reserve fuel quantity

Approx. 3.7 quarts (Approx. 3.5 l)

- Press fuel tank cap down firmly to close.
- Remove the ignition key and close the protective flap.

**Refueling procedure**

– with Keyless Ride<sup>OE</sup>

**Requirement**

Steering lock is unlocked.

 **WARNING**

**Fuel is highly flammable**

Fire and explosion hazard

- Do not smoke. Never bring a naked flame near the fuel tank.◀

 **WARNING**

**Escaping of fuel due to expansion under exposure to heat with overfilled fuel tank**

Accident hazard

- Do not overfill the fuel tank.◀

 **ATTENTION**

**Contact of fuel and plastic surfaces**

Damage to surfaces (become unattractive or cloudy)

- Immediately clean plastic surfaces after contact with fuel.◀
- Put the motorcycle up on the side stand, ensuring that it is

resting on a firm and level support surface.

- with Keyless Ride<sup>OE</sup>
- Switch off ignition (▶▶▶ 77).

 **NOTICE**

After the ignition is switched off, the fuel filler cap can be opened within the specified run-on time even without the radio-operated key being within the reception area.◀



After-running period for opening the fuel filler cap

2 min

- » There are **2 ways** to open the fuel filler cap:
  - Within the after-run time period.
  - After the after-run period is over.

- with center stand<sup>OE</sup>

 **WARNING**

**Fuel is highly flammable**

Fire and explosion hazard

- Do not smoke. Never bring a naked flame near the fuel tank.◀

 **WARNING**

**Escaping of fuel due to expansion under exposure to heat with overfilled fuel tank**

Accident hazard

- Do not overfill the fuel tank.◀

 **ATTENTION**

**Contact of fuel and plastic surfaces**

Damage to surfaces (become unattractive or cloudy)

- Immediately clean plastic surfaces after contact with fuel.◀

- Put the motorcycle up on the center stand, ensuring that it is resting on a firm and level support surface.
- with Keyless Ride<sup>OE</sup>
- Switch off ignition (▶▶▶ 77).



## NOTICE

After the ignition is switched off, the fuel filler cap can be opened within the specified run-on time even without the radio-operated key being within the reception area.◀



After-running period for opening the fuel filler cap

2 min

- » There are **2 ways** to open the fuel filler cap:
  - Within the after-run time period.
  - After the after-run period is over.◀

## Version 1

– with Keyless Ride<sup>OE</sup>

### Requirement

Within the after-running period



- Slowly pull up tab **1** of fuel filler cap.
- » Fuel filler cap unlocked.
- Open fuel filler cap completely.

## Version 2

– with Keyless Ride<sup>OE</sup>

### Requirement

After run-on time expires

- Bring radio-operated key into reception range.
- Slowly pull up tab **1**.
  - » The indicator light for the radio-operated key flashes as long as the radio-operated key is being searched for.
- Slowly pull up tab **1** of fuel filler cap again.
  - » Fuel filler cap unlocked.
- Open fuel filler cap completely.



- Refuel with a fuel meeting the specifications above, continuing until fuel is no higher than lower edge of filler neck.



## NOTICE

If refueling is carried out after running on fuel reserve, the resulting filling capacity must be greater than the fuel reserve so that the new fill level is detected and the fuel reserve indicator light is switched off.◀



## NOTICE

The "usable fuel quantity" specified in the technical data is the fuel quantity, which can be refueled if the fuel tank was completely emptied, i.e., if the engine dies off due to lack of fuel.◀



Tank capacity

Approx. 4 gal (Approx. 15 l)



Reserve fuel quantity

Approx. 3.7 quarts (Approx. 3.5 l)

- Press fuel filler cap of fuel tank down firmly.
  - » Fuel filler cap audibly engages.
  - » Fuel filler cap automatically locks after run-on time expires.
  - » The engaged fuel filler cap locks immediately when the steering lock is locked or during starting.

### Securing motorcycle for transport

- Protect against scratching on all components where tensioning straps are placed. (For example, use adhesive tape or soft cloths).



## ATTENTION

### Motorcycle tips to the side when raising

Component damage cause by tipping over

- Secure the motorcycle against tipping to the side, preferably with the assistance of a second person.◀
- Push motorcycle onto transport surface, and do not place on side stand or center stand.



## ATTENTION

### Pinching of components

Component damage

- Do not pinch components, e.g. brake lines or wiring harnesses. ◀
- Fasten straps at front on both sides on lower fork bridge and tension.

- Place straps at rear on both sides on rear frame and tension.
- Tighten all straps evenly.

## Technology in detail

General notes.....	164
Antilock Braking System (ABS) ....	164
Traction control (ASC/DTC).....	166
Riding mode .....	168
Tire pressure control (TPC/RDC).....	171
Gear Shift Assistant.....	172

## General notes

More information on the topic of technology is available at:

**[bmw-motorrad.com/technology](http://bmw-motorrad.com/technology)**

## Antilock Braking System (ABS)

### How does ABS work?

The maximum braking force that can be transferred to the road surface is partially dependent on the friction coefficient of the road surface. Gravel, ice, snow and wet roads offer a considerably poorer friction coefficient than a dry, clean asphalt surface. The poorer the friction coefficient of the road surface is, the longer the braking distance will be. If the maximum transferable braking force is exceeded when the rider increases the brake pressure, the wheels begin to lock and driving stability is lost, and a

fall can result. Before this situation occurs, ABS intervenes and adjusts the brake pressure to the maximum transferable braking force. This enables the wheels to continue to turn and maintains riding stability regardless of the road condition.

### What happens when rough roads are encountered?

Bumpy or rough roads can briefly lead to a loss of contact between the tires and the road surface, until the transferable braking force is reduced to zero. If the brakes are applied in this situation, the ABS must reduce the brake pressure to ensure driving stability when contact to the road is restored. At this point, the BMW Motorrad ABS must assume extremely low friction coefficients (gravel, ice, snow) so that the running wheels turn in

every imaginable case and the driving stability is ensured. After detecting the actual conditions, the system adjusts the optimum brake pressure.

### Lifting off rear wheel

During extremely heavy and rapid decelerations, however, it is possible under certain circumstances that the BMW Motorrad Antilock Brake System cannot prevent the rear wheel from lifting off the ground. In these cases, the motorcycle can also flip end over end.



## WARNING

### Lifting off of the rear wheel due to heavy braking

Accident hazard

- When braking heavily, bear in mind that the ABS control cannot always be relied on to prevent the rear wheel from lifting off the ground. ◀

## What are the design characteristics of the BMW Motorrad ABS?

The BMW Motorrad ABS ensures riding stability on any surface within the limits of riding physics.

From a speed greater than 2.5 mph (4 km/h), the BMW Motorrad ABS can ensure riding stability on any surface within the limits of riding physics. At lower speeds, the BMW Motorrad ABS cannot provide optimal support on all surfaces due to system limitations.

The system is not optimized for the special conditions encountered under the extreme conditions of competitive off-road and race-track use.

## Special situations

To detect the tendency of the wheels to lock up, the speeds of the front and rear wheel are compared. If implausible values are detected over a longer period of time, the ABS function is deactivated for safety reasons and an ABS error is indicated. A self-diagnosis routine must be completed before the error will be displayed.

Apart from problems with the BMW Motorrad ABS, unusual riding conditions can also cause a fault message to be generated:

- Driving on the rear wheel (wheelie) for a longer period.
- Rear wheel spinning in place with front brake engaged (burn out).
- Warm-up on the center or auxiliary stand at idle or with gear engaged.

- Locked-up rear wheel for a longer period of time, e.g. when riding downhill offroad.

Should a fault code occur due to an unusual driving condition, the ABS function can be reactivated by switching the ignition off and then on again.

## How important is regular maintenance?

### **WARNING**

#### **Brake system not regularly serviced**

Accident hazard

- To ensure that the BMW Motorrad ABS is in a properly maintained condition, it is vital that the specified service intervals are kept to. ◀

## Reserves for safety

But remember, the potentially shorter braking distances which the BMW Motorrad ABS permits must not be used as an excuse for careless riding. ABS is primarily a means of ensuring a safety margin in genuine emergencies.

Be careful in curves! When you apply the brakes on a corner, the motorcycle's weight and momentum take over and even the BMW Motorrad ABS is unable to counteract their effects.

## Further development of ABS to ABS Pro

– with ABS Pro<sup>OE</sup>

In the past, the BMW Motorrad ABS system provided for a very high level of safety while braking during straight-ahead riding. Now ABS Pro also offers increased safety even when brak-

ing in curves. ABS Pro stops the wheels from locking up, even in the event that the brakes are applied quickly. ABS Pro reduces abrupt changes in steering forces, especially during shock braking, and therefore decreases the risk of the occurrence of inadvertent lift-off of the vehicle.

## ABS control

From a technical standpoint, ABS Pro adjusts the ABS control to the angle of inclination of the motorcycle in dependence on the respective riding situation. Signals for the roll and yaw rate and the lateral acceleration are used to determine the inclination of the motorcycle.

With an increasing inclination, the brake pressure gradient is increasingly limited at the start of braking. This results in a slower pressure buildup. In addition, the pressure modulation in the range

of the ABS control is more uniform.

## Advantages for the rider

The advantages of ABS Pro for the rider are sensitive response and high braking and riding stability with the best possible deceleration, even in curves.

## Traction control (ASC/DTC)

### How does traction control work?

Traction Control is available in two versions

- **Without** taking the angle into account: Automatic Stability Control ASC
- ASC is a rudimentary function intended to prevent falls.
- **With** taking the angle into account: Dynamic Traction Control DTC

- The additional inclined position and acceleration information enables the DTC to make more precise and comfortable adjustments.

The traction control compares the wheel circumferential velocities of the front and rear wheel. The slip, and with it the stability reserves at the rear wheel, are determined from the speed difference. The engine control adapts the engine torque when the slip limit is exceeded. BMW Motorrad ASC/DTC is designed as an assistance system for the rider and for riding on public roads. The extent to which the rider affects ASC/DTC control can be considerable (weight shifts when cornering, loose luggage on the motorcycle), especially when approaching the limits imposed by the laws of physics.

The **Enduro** riding mode should be activated for off-road riding. In this mode, the controlling intervention by the ASC/DTC is performed later, enabling controlled drifting.

The system is not optimized for the special conditions encountered under the extreme conditions of competitive off-road and race-track use. BMW Motorrad ASC/DTC can be switched off in such instances.

### **WARNING**

#### **Risky riding style**

Accident hazard despite ASC/DTC

- The rider is always responsible for adapting his/her driving style.
- Do not reduce the system's extra safety margin with careless riding or unnecessary risks. ◀

## **Special situations**

As lean angles increase, acceleration capability is also progressively restricted by the laws of physics. This can result in reduced acceleration when coming out of very tight curves.

To detect spinning or slipping away of the rear wheel, among other things the speeds of the front and rear wheel are compared and the angle with DTC compared to ASC is taken into account.

- with riding modes Pro<sup>OE</sup>  
If the values for the angle are detected to be implausible for a long period, a replacement value is used for the angle, or the DTC function is deactivated. In these cases, a DTC error is displayed. A self-diagnosis routine must be completed before the fault memory entry will be displayed.

Under the following unusual riding conditions, BMW Motorrad Traction Control may be deactivated automatically.

### Unusual riding conditions:

- Riding on the rear wheel (wheelie) for a longer period.
- Rear wheel spinning in place with front wheel brake engaged (burn out).
- Warming up the engine on an auxiliary stand at idle or with gear engaged.

If the coding plug is not in use, turning the ignition off and on again and then riding the motorcycle at a minimum speed reactivates the DTC after a fault.



Minimum speed for DTC activation

min 3 mph (min 5 km/h)

If the front wheel loses contact with the ground under extreme acceleration, the ASC or DTC function reduces the engine torque in the RAIN and ROAD riding modes until the front wheel makes contact with the ground again.

The riding modes ENDURO and ENDURO PRO are designed for off-road riding and are not suitable for road operation.

In the riding modes DYNAMIC and ENDURO, the front wheel lift-off detection permits brief wheelies.

The front wheel lift-off detection is switched off in riding mode ENDURO PRO.

BMW Motorrad recommends that you respond to the front wheel lifting off by twisting back the throttle grip somewhat to return to a stable riding condition as quickly as possible.

On a slippery surface, the throttle grip should never be suddenly twisted back completely unless the clutch is disengaged at the same time. The engine braking torque can cause the rear wheel to slip, resulting in an unstable riding state. This case cannot be controlled by BMW Motorrad DTC.

## Riding mode Selection

In order to adjust the motorcycle to the road condition and the desired riding experience, it is possible to select one of the following riding modes:

- RAIN
- ROAD (standard mode)

- with riding modes Pro<sup>OE</sup>
- DYNAMIC
- ENDURO

With the encoding plug installed, the ENDURO PRO riding mode replaces the ENDURO riding mode.

For each of these riding modes, there is a coordinated setting for the ABS and ASC/DTC systems as well as for the throttle response.

- with Dynamic ESA<sup>OE</sup>

The coordination of the Dynamic ESA also depends on the selected riding mode.

ABS and/or ASC/DTC can be switched off in any riding mode. The following explanations always refer to the riding safety systems that are switched on.

### **Throttle response**

- In the RAIN and ENDURO riding modes: the response characteristics of the engine are restrained.
- In riding modes ROAD and ENDURO PRO: The response characteristics of the engine are optimum and direct.
- In the DYNAMIC riding mode: the response characteristics of the engine are optimal and dynamic.

### **ABS**

- The rear wheel lift-off detection is active in all riding modes except ENDURO PRO.
- In the DYNAMIC and ENDURO riding modes, rear wheel lift-off detection is reduced in order to achieve a greater braking effect.
- In the RAIN, ROAD, and DYNAMIC riding modes, ABS is attuned for road use.

- In the ENDURO riding mode, ABS is attuned for off-road use with road tires.

- with riding modes Pro<sup>OE</sup>

- In riding mode ENDURO PRO, there is no ABS control on the rear wheel when the footbrake lever is actuated. The ABS is attuned for off-road use with road tires.
- In the RAIN, ROAD, and DYNAMIC riding modes, ABS Pro available to its full capacity. The stand-up tendency the motorcycle has when braking in curves is reduced to a minimum.
- In the ENDURO riding mode, ABS Pro is only available in good traction conditions. The support is reduced compared to the ROAD riding mode and is instead aimed at achieving the greatest braking effect.

- In the ENDURO PRO riding mode, the ABS Pro is not available.

- without riding modes Pro<sup>OE</sup>

### **ASC**

- Front wheel lift-off detection is active in all riding modes.

- ASC is attuned for road use.

- In the ROAD riding mode, ASC provides high riding stability, and maximum riding stability in the RAIN riding mode.

- with riding modes Pro<sup>OE</sup>

### **DTC**

#### **Tires**

- In the RAIN, ROAD, and DYNAMIC riding modes, DTC is attuned for road use with road tires.

- In the ENDURO riding mode, DTC is attuned for off-road use with road tires.

- In the ENDURO PRO riding mode, the DTC is attuned to off-road use with lugged tires.

### **Riding stability**

- In the RAIN riding mode, DTC intervenes early enough to ensure maximum riding stability is achieved.

- In the ROAD riding mode, DTC intervenes at a later point than in the RAIN riding mode. A rear wheel spin is avoided wherever possible.

- In the RAIN and ROAD riding modes, the front wheel is prevented from lift-off.

- In the DYNAMIC riding mode, DTC intervenes later than in the ROAD riding mode so that minor drifts are possible at the end of curves and brief wheelies.

- In the ENDURO riding mode, DTC intervenes even later and it is set to off-road use so that

longer drifts and brief wheelies are possible at the end of curves.

- In the ENDURO PRO riding mode, the control of the DTC assumes that lugged tires are being used for off-road riding. Longer wheelies as well as wheelie at small angles are permitted. The front wheel lift-off detection is switched off, which means that it is possible to flip over in extreme cases!

### **Changing setting**

Riding modes can be changed when the vehicle is at a standstill with the ignition switched on. A changeover while riding is possible under the following conditions:

- No drive torque at rear wheel.
- No brake pressure in the braking system.

For a changeover while riding, the following steps must be carried out:

- Turn back throttle grip.
- Do not actuate brake lever.

First the desired riding mode is preselected. The new selection is not activated until the specified conditions are present in all affected systems.

The selection menu does not disappear in the display until the riding mode has been switched over.

## Tire pressure control (TPC/RDC)

- with tire pressure monitor (TPM)<sup>OE</sup>

## Operation

A sensor located in each tire monitors the air temperature and the inflation pressure inside the tire and transmits this information to the control unit.

The sensors are equipped with a centrifugal controller, which does not enable the transmission of the measured values until the minimum speed is exceeded for the first time.

 Minimum speed for the transmission of the TPC/RDC measured values:
min 19 mph (min 30 km/h)

Before initial reception of the tire pressure, -- is shown in the display for each tire. The sensors continue to transmit the measured readings for some time after the vehicle comes to a stop.

 Transmission time of the measured values after vehicle standstill:
min 15 min

If an TPC/RDC control unit is installed but the wheels have no sensors, a fault message is generated.

## Tire inflation pressure ranges

The TPC/RDC control unit distinguishes between three inflation pressure ranges matched to the motorcycle:

- Inflation pressure within the permissible tolerance.
- Inflation pressure at the limits of the permissible tolerance.
- Inflation pressure outside the permissible tolerance.

## Temperature compensation

The tire inflation pressure is temperature dependent, i.e. it increases or decreases together with the tire air temperature. The tire temperature is dependent on the outside temperature, the riding style and the length of the journey.



The tire pressures are shown in the display with temperature compensation and are always based on the following tire air temperature:

68 °F (20 °C)

Tire pressure gages at gas stations do not make any adjustment for the air temperature, the tire pressure indicated depends on the temperature of the air in the tire. As a result, in most cases the values displayed there

do not match the values shown in the display.

## Tire pressure adjustment

Compare the TPC/RDC value in the display with the value on the back cover of the operating instructions. The difference between the two values must be compensated with the tire inflation pressure tester at the filling station.



Example

According to the rider's manual, the tire pressure should have the following value:

36.3 psi (2.5 bar)

The following value is indicated in the display:

33.4 psi (2.3 bar)

Missing is thus:



Example

2.9 psi (0.2 bar)

The tester at the filling station shows:

34.8 psi (2.4 bar)

To produce the correct tire pressure, this must be increased to the following value:

37.7 psi (2.6 bar)

## Gear Shift Assistant

– with riding modes Pro<sup>OE</sup>

### Pro gearshift assistant

Your motorcycle is equipped with a Pro gearshift assistant originally developed for racing but now specially adapted for touring use. It allows you upshift and downshift under almost any load conditions and in virtually all engine-

speed ranges without operating the clutch or accelerator.

## Benefits

- 70-80 % of all gear changes can be performed without using the clutch.
- Less movement between pilot and pillion due to shorter gear-change intervals.
- Throttle does not have to be closed when changing gear under acceleration.
- During deceleration and downshifts (throttle plate closed) the system blips the throttle to obtain the correct engine speed.
- Shifting times are faster than when the clutch is used to change gears.

For the system to detect the rider's intention to change gear, the gearshift lever previously not operated must be moved against the force of the spring by a cer-

tain amount of "overtravel" in the desired direction with a normal to brisk action and held in that position until the gear change is completed. A further increase of the force applied to the gearshift lever during the gear-shift operation is not necessary. After the gear change is completed, the gear lever must be fully released before the Pro gearshift assistant can execute a new gear change. The load factor (throttle grip position) should remain constant both prior to and during execution of shifts using the Pro gearshift assistant. Changing the accelerator twist-grip position during the gear-shift operation may cause the function to abort and/or the gear change to fail. The Pro gearshift assistant does not provide support when gear changes are made using the clutch.

## Downshifts

- Downshifts are assisted up to the speed at which the engine reaches maximum rpm in the gear to be engaged. Over-revving is thus prevented.



Maximum engine speed

max 9000 min<sup>-1</sup>

## Upshifts

- Upshifting is supported until the idling speed is reached in the target gear.
- This prevents the idling speed from being dropped below.



Idle speed

1250 min<sup>-1</sup> (Engine at operating temperature)



## Maintenance

General notes.....	176	Battery.....	205
Tool kit .....	176	Fuses .....	208
Service tool set .....	177	Diagnostic socket.....	209
Front wheel stand .....	177	Chain .....	210
Engine oil .....	178		
Brake system .....	180		
Clutch .....	184		
Coolant .....	186		
Tires .....	187		
Wheel rims and tires .....	188		
Wheels .....	189		
Air filter .....	198		
Light sources .....	200		
Trim panel components .....	203		
Jump-starting.....	203		

## General notes

The Maintenance chapter describes work involving the checking and replacement of wear parts that can be performed with a minimum of effort.

If special tightening torques are to be taken into account for assembly, these are listed. An overview of all required tightening torques is contained in the Technical Data chapter.

Information on additional maintenance and repair work is provided in the Repair Manual for your motorcycle on DVD, which you can obtain from your authorized BMW Motorrad retailer.

Special tools and thorough specialized knowledge are required to carry out some of the work described here. If you are in doubt, consult an authorized workshop, preferably your authorized BMW Motorrad retailer.

## Tool kit

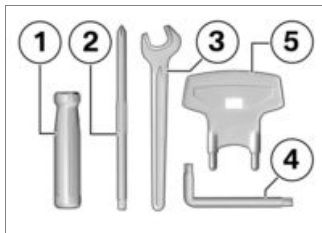

- 1** Screwdriver handle
- 2** Reversible screwdriver insert with Phillips and straight blade
  - Replacing front and rear turn indicator light sources (➡ 200).
  - Replacing the license-plate bulb (➡ 201).
  - Removing battery (➡ 206).
  - Adjusting the damping characteristic for rear wheel (➡ 141).

- 3** Open-ended wrench  
Wrench size: 14 mm
  - Adjusting mirror arm (➡ 138).
- 4** Torx wrench, T25/T30  
T25 on short end, T30 on long end
  - Remove the tank cover (➡ 203).
- 5** Hand lever
  - Adjusting the spring preload on the rear wheel (➡ 140).

## Service tool set

– with service tool set<sup>OA</sup>

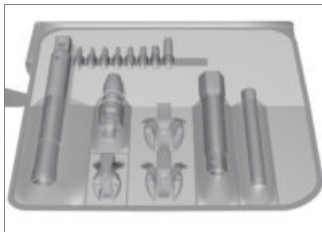

For expanded servicing (e.g. fitting and removing wheels), BMW Motorrad has set up a service toolkit designed for your motorcycle. You can obtain the toolkit from your BMW Motorrad retailer.

## Front wheel stand Mount front wheel stand

### ATTENTION

#### Use of the BMW Motorrad front wheel stand without an auxiliary stand

Component damage cause by tipping over

- Place the motorcycle on an auxiliary stand before lifting the front wheel with the BMW Motorrad front-wheel stand.◀
- Place motorcycle on a suitable auxiliary stand.
- with center stand<sup>OE</sup>
- Place motorcycle on center stand, ensuring that it is resting on a firm and level support surface.◀
- Use basic stand with part number (83 30 0 402 241) in

combination with front-wheel adapter (83 30 0 402 242).

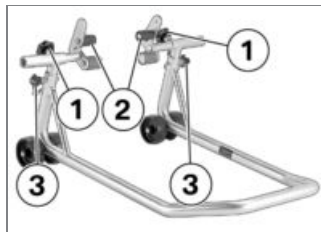

- Loosen mounting bolts **1**.
- Push two mounts **2** outward, continuing until front suspension fits between them. Adjust pressure bolts accordingly to the front suspension.
- Use locating pins **3** to set front wheel stand to desired height.
- Center front wheel stand relative to front wheel and push it against front axle.

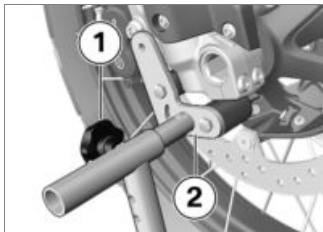

- Align two mounts **2** so that front suspension rests securely on them.
- Tighten mounting bolts with wheel **1**.



- Apply uniform pressure to push front wheel stand down and raise motorcycle.

– with center stand<sup>OE</sup>



### ATTENTION

#### Lifting-off of the center stand if the vehicle is raised too high

Component damage cause by tipping over

- When raising the motorcycle, make sure that the center stand remains on the ground.

- Adjust the height of the front wheel stand if necessary.◀
- Ensure that motorcycle is standing securely.<

## Engine oil

### Checking engine oil level



### ATTENTION

**Misinterpretation of the oil filling quantity, as the oil level is temperature-dependent (the higher the temperature, the higher the oil level)**

Engine damage

- Only check the oil level after a longer journey or when the engine is warm.◀
- Wipe the area around the oil filler opening clean.
- Allow the engine to idle until the fan starts up, then allow it to idle one minute longer.
- Switch off engine.

- Make sure ground is level and firm and hold motorcycle at operating temperature vertically.
  - with center stand<sup>OE</sup>

## ATTENTION

### Motorcycle tips to the side when raising

Component damage cause by tipping over

- Secure the motorcycle against tipping to the side, preferably with the assistance of a second person.◀
- Check that the engine is at operating temperature, make sure the ground is level and firm and put the motorcycle up on its center stand.<

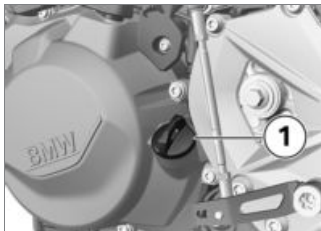

- Wait five minutes to allow oil to drain into the oil pan.
- Remove oil level dipstick **1**.

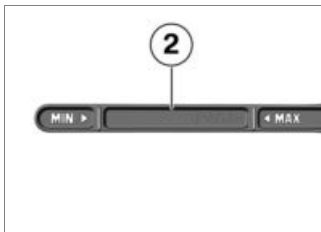

- Clean measuring range **2** using a dry cloth

- Fit the oil level dipstick onto the oil filler opening, however do not screw in.
- Remove oil level dipstick and check oil level.

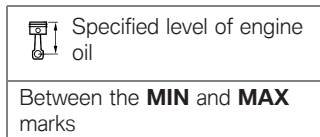
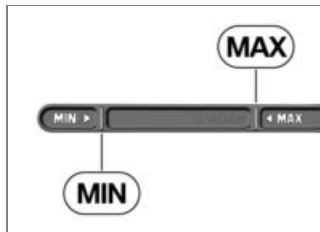



Engine oil, quantity for topping up

Product recommended by BMW Motorrad: ADVANTEC Ultimate oil, SAE 5W-40, API SL/JASO MA2

max 0.5 quarts (max 0.5 l) (Difference between MIN and MAX)

If oil level is below minimum mark:

- Topping up engine oil (▶▶▶ 180).

If oil level is above maximum mark:

- Have oil level corrected at a specialist workshop, preferably an authorized BMW Motorrad retailer.
- Install oil dipstick.

## Topping up engine oil

- Park motorcycle, ensuring that support surface is firm and level.
- Clean area adjacent to oil fill location.

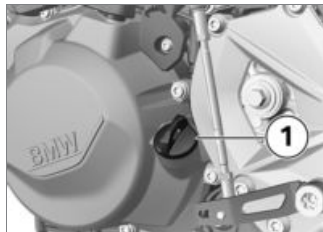

- Remove oil dipstick **1**.



### ATTENTION

## Use of too little or too much engine oil

Engine damage

- Always make sure that the oil level is correct.◀

- Add engine oil up to specified level.
- Checking engine oil level (▶▶▶ 178).
- Install oil dipstick.

## Brake system

### Checking function of brakes

- Actuate brake lever.
  - » The pressure point must be clearly perceptible.
- Press the footbrake lever.
  - » The pressure point must be clearly perceptible.

If pressure points are not clearly perceptible:



### ATTENTION

## Improper working on the brake system

Endangering of the operating safety of the brake system

- Have all work on the brake system carried out by experts.◀

- Have the brakes checked by a specialist workshop, preferably an authorized BMW Motorrad dealer.

## Checking the front brake pad thickness

- Park motorcycle, ensuring that support surface is firm and level.



- Visually inspect left and right brake pads to determine their thickness. Direction of view: between wheel and front suspension toward brake caliper **1**.

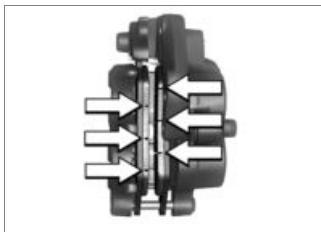

 Front brake-pad wear limit

min 0.04 in (min 1.0 mm)  
(Only friction material without carrier plate. The wear markings, i.e. the grooves, must be clearly visible.)

If the wear indicators are no longer clearly visible:

 **WARNING**

**Dropping below the minimum pad thickness**

Reduced braking action, damage to the brake

- In order to ensure the operating reliability of the brake system, make sure that the brake pads are not worn beyond their minimum thickness. ◀
- Have brake pads replaced at an authorized service facility, preferably an authorized BMW Motorrad retailer.

## Checking the rear brake pad thickness

- Park motorcycle, ensuring that support surface is firm and level.



- Conduct a visual inspection of the brake pad thickness. Direction of view: from rear onto brake caliper **1**.

 Rear brake-pad wear limit

min 0.04 in (min 1.0 mm)  
(Only friction material without carrier plate.)

If brake pads are worn:

 **WARNING**

**Dropping below the minimum pad thickness**

Reduced braking action, damage to the brake

- In order to ensure the operating reliability of the brake system, make sure that the brake pads are not worn beyond their minimum thickness. ◀
- Have brake pads replaced at an authorized service facility, preferably an authorized BMW Motorrad retailer.

## Checking the front brake fluid level

 **WARNING**

### Insufficient or contaminated brake fluid in the brake fluid reservoir

Considerably reduced braking power caused by air, dirt or water in the brake system

- Stop riding immediately until fault is rectified.

- Check brake fluid level regularly.
- Make sure that the lid of the brake fluid reservoir is cleaned before opening.
- Make sure that brake fluid is used from a sealed container only. ◀
- with center stand<sup>OE</sup>
- Make sure the ground is level and firm and put the motorcycle up on its center stand.
- Move handlebars to straight-ahead position. ◀
- Make sure ground is level and firm and hold motorcycle vertically.
- Move handlebars to straight-ahead position.



- Check brake fluid level at brake fluid reservoir for front wheel brake **1**.



### NOTICE

The brake fluid level in the brake-fluid reservoir drops due to brake pad wear. ◀



Front brake fluid level

Brake fluid, DOT4

The brake fluid level must not fall below the MIN mark. (Brake fluid reservoir horizontal, motorcycle standing upright)

If the brake fluid level falls below the approved level:

- Have the defect rectified as quickly as possible by a specialist workshop, preferably an authorized BMW Motorrad retailer.

## Checking the rear brake fluid level

- Make sure ground is level and firm and hold motorcycle vertically.
  - with center stand<sup>OE</sup>
- Make sure ground is level and firm and place motorcycle on its center stand. ◀

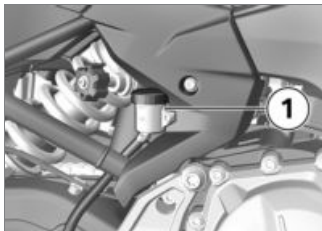

### WARNING

#### Insufficient or contaminated brake fluid in the brake fluid reservoir

Considerably reduced braking power caused by air, dirt or water in the brake system

- Stop riding immediately until fault is rectified.
- Check brake fluid level regularly.
- Make sure that the lid of the brake fluid reservoir is cleaned before opening.

- Make sure that brake fluid is used from a sealed container only. ◀
- Read brake fluid level at rear brake-fluid reservoir **1**.

### NOTICE

The brake fluid level in the brake-fluid reservoir drops due to brake pad wear. ◀

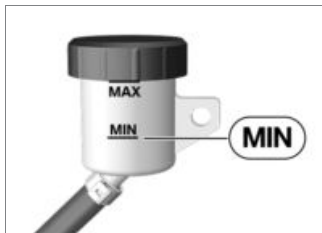

 Rear brake fluid level (visual inspection)

Brake fluid, DOT4

 Rear brake fluid level (visual inspection)

The brake fluid level must not fall below the **MIN**.

If brake fluid level falls below the approved level:

- Have defect corrected as soon as possible by an authorized workshop, preferably an authorized BMW Motorrad retailer.

## Clutch

### Checking clutch function

- Pull back the clutch lever.
    - » A rising force must be perceptible upon increasing operation.
- If no rising force can be felt upon increasing operation:
- Have the clutch checked by an authorized workshop, preferably an authorized BMW Motorrad retailer.

## Checking clutch pedal free play

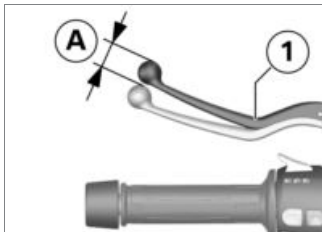

- Actuate clutch lever **1** several times until it touches the handle.
- Actuate clutch lever **1** slightly until you can feel resistance while observing the free play of the clutch pedal **A**.

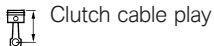

0.12...0.2 in (3...5 mm) (along the outside of the hand lever, handlebars in the straight-ahead position, when the engine is cold)

If free play in the clutch is outside of tolerance:

- Adjusting clutch play (▮▮▮ 185).

## Adjusting clutch play

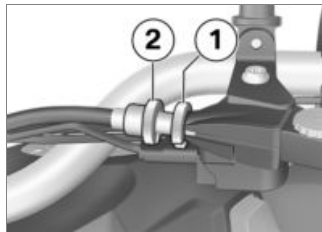

- Loosen lock nut **1**.

- To increase clutch play: turn adjusting screw **2** into handlebar fitting.
- To decrease clutch play: turn adjusting screw **2** out of handlebar fitting.



### NOTICE

The distance between locknuts and nuts (measured inside) must not exceed 14 mm.

If the correct clutch play can only be set through further unscrewing, contact a specialist workshop, preferably a BMW Motorrad retailer. ◀

- Checking clutch pedal free play (▮▮▮ 185).
- Tighten locknuts **1** while holding adjusting screw **2** in place.

## Coolant

### Checking coolant level

- Park motorcycle on a level, firm surface.
- Turn the handlebars to the right.

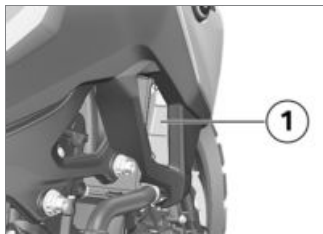

- Read the coolant level on the expansion tank **1**. Line of sight: from the rear, through the opening and into the right side trim panel.



Required coolant level

Between the MIN - MAX marks on the expansion tank (Engine cold)

If coolant level drops below approved level:

- Add coolant.

### Top up coolant

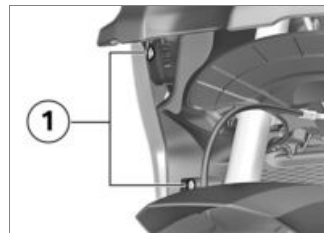

- Unscrew the radiator cowl screws **1** from the inside.

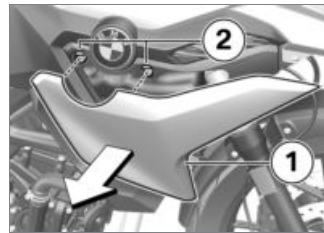

- Remove radiator cowl **1** from the brackets **2**.

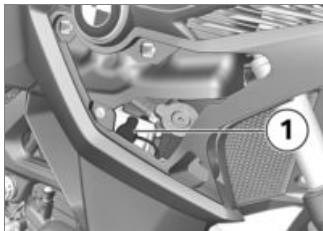

- Open cap **1** of expansion tank.
- Top up the coolant to the specified level using a suitable funnel.
- Close cap of expansion tank.

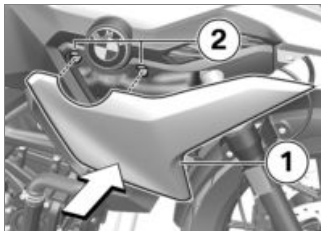

- Insert radiator cowl **1** into bracket **2**.
  - » The radiator cowl clicks in audibly.

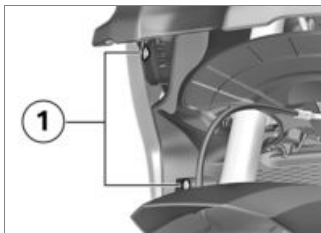

- Tighten the radiator cowl screws **1** from the inside.

## Tires

### Checking the tire pressure

**! WARNING**

#### Incorrect tire inflation pressure

Poorer handling characteristic of motorcycle, reduction of tire service life

- Ensure proper tire inflation pressure. ◀

**! WARNING**

#### Automatic opening of vertically installed valve inserts at high speeds

Sudden loss of tire inflation pressure

- Use valve caps with rubber sealing ring and screw on firmly. ◀
- Park motorcycle, ensuring that support surface is firm and level.

- Check tire pressures against data below.



Front tire pressure

31.9 psi (2.2 bar) (One-up, with cold tires)

36.3 psi (2.5 bar) (Driver with passenger and/or load, with cold tire)



Rear tire pressure

36.3 psi (2.5 bar) (One-up, with cold tires)

42.1 psi (2.9 bar) (Driver with passenger and/or load, with cold tire)

If tire pressure is too low:

- Correct tire pressure.

## Wheel rims and tires

### Checking rims

- Park motorcycle, ensuring that support surface is firm and level.
- Subject wheel rims to visual inspection for defects.
- Have damaged rims checked and, if necessary, replaced by a specialist service facility, preferably an authorized BMW Motorrad retailer.

### Checking spokes

- Park motorcycle, ensuring that support surface is firm and level.
- Using the handle of a screwdriver or similar object, run it over the spokes and listen to the sound pattern.

If the sound pattern is uneven:

- Have spokes checked by a specialist workshop,

preferably by an authorized BMW Motorrad Retailer.

### Check tire tread depth



#### WARNING

#### Riding with heavily worn tyres

Risk of accident due to poorer rideability

- If necessary, replace the tyres before the legally specified minimum tread depth is reached. ◀
- Park motorcycle, ensuring that support surface is firm and level.
- Measure tire tread depth in main tread grooves with wear indicators.



#### NOTICE

Tread wear marks are integrated into the main grooves on every tire. If the tire tread has worn

down to the level of the marks, the tire is completely worn. The locations of the marks are indicated on the edge of the tire, e.g. by the letters TI, TWI or by an arrow. ◀

When the minimum tread depth is reached:

- Replace the worn tires.

## Wheels

### Tire recommendation

For every size of tire, BMW Motorrad has tested and approved certain makes as roadworthy. BMW Motorrad cannot evaluate the suitability of other tires, and can therefore take no responsibility for their driving safety.

BMW Motorrad recommends only using the tires tested and approved by BMW Motorrad. Detailed information can be obtained from your authorized

BMW Motorrad Retailer or online at

**bmw-motorrad.com**

### Affect of wheel sizes on suspension control systems

The wheel sizes play a major role in the ABS and ASC suspension-control systems. The diameter and width of the wheels stored in the control unit have particular significance as the basis for all necessary calculations. A change in these sizes resulting from conversion to wheels not installed as standard equipment can seriously affect the control efficiency of these systems.

The sensor wheels required for wheel speed detection must also match the installed control systems and may not be replaced. If you want to equip your motorcycle with different wheels, please contact a specialist

service facility, preferably a BMW Motorrad retailer. In some cases the data stored in the control units can be adapted for the new wheel sizes.

### Removing front wheel

- Park motorcycle. Ensure that the ground is firm and level.

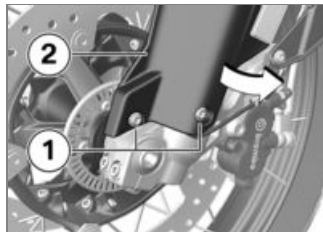

- Remove screws **1**.
- Carefully swing the lower part of the front wheel cover **2** in arrow direction.

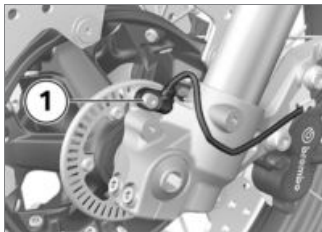

- Remove screw **1** and remove wheel speed sensor from the bore.

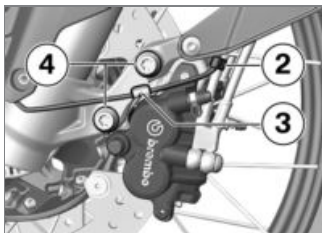

- Detach wheel speed sensor cable from holding clips **2** and **3**.

- Remove the mounting bolts **4** of the left and right brake caliper.

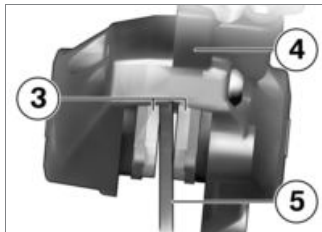

- Push the brake pads **3** apart slightly by turning the brake caliper **4** against the brake disc **5**.
- Mask off areas of wheel rim that could be scratched in the process of removing the brake calipers.



### ATTENTION

#### Unintentional pressing together of brake pads

Component damage when mounting the brake caliper or when pressing the brake pads apart

- Do not actuate the brakes with the brake caliper removed. ◀
- Carefully pull the brake calipers back and outward to remove them from brake discs.
- Place motorcycle on a suitable auxiliary stand.
  - with center stand<sup>OE</sup>
- Put the motorcycle up on the center stand, ensuring that it is resting on a firm and level support surface. ◀
- Raise front of motorcycle until the front wheel can turn freely. BMW Motorrad recommends using the BMW Motorrad front wheel stand for lifting the motorcycle.

- Mount front wheel stand (→ 177).

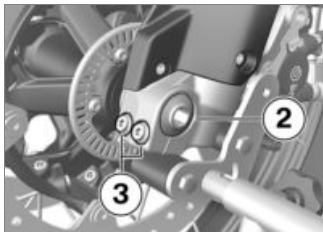

- Remove axle screw **2**.
- Loosen left-hand axle clamping screws **3**.



- Loosen axle clamping screws **1** on right side.

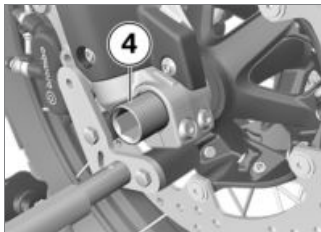

- Remove axle **4** while supporting wheel.
- Do not remove grease on axle.

- Roll front wheel forward to remove it.

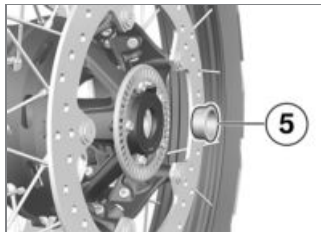

- Remove spacer bushing **5** on left side from wheel hub.

## Installing the front wheel

### WARNING

#### Use of a wheel which does not comply with series specifications

Malfunctions during control interventions by ABS and ASC

- Please see the information on the effect of wheel sizes on the ABS and ASC chassis control systems at the beginning of this chapter. ◀

### ATTENTION

#### Tightening of screwed connections with incorrect tightening torque

Damage or loosening of screwed connections

- Always have the tightening torques checked by a specialized workshop, preferably an authorized BMW Motorrad retailer. ◀

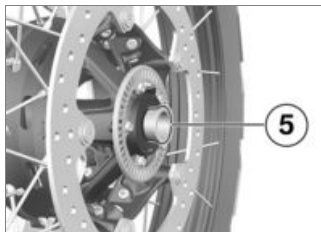

- Insert spacer bushing **5** on left side in wheel hub.

### ATTENTION

#### Front wheel installation opposite the running direction

Accident hazard

- Observe running direction arrows on tire or rim. ◀
- Roll front wheel into front suspension while guiding the brake disc between the brake pads on the left brake caliper.

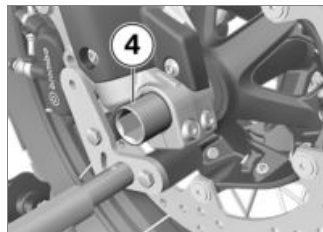

- Raise front wheel and insert axle **4** as far as possible.
- Remove front wheel stand and firmly compress front forks. Do not actuate handbrake lever at the same time.
- Mount front wheel stand (▶ 177).

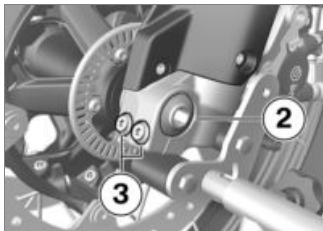



- Install the axle screw **2** using an appropriate torque. Brace quick-release axle on the right side at the same time.

 Axle screw in front quick-release axle

37 lb/ft (50 Nm)

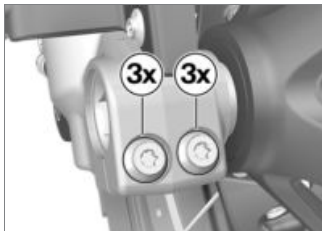
- Tighten left-hand axle clamping screws **3** using an appropriate torque.



 Pinch bolt on quick-release axle

Tightening sequence: Tighten the screws 6 times, alternating between one and the other each time

14 lb/ft (19 Nm)



- Tighten right axle clamping screws **1** using an appropriate torque.

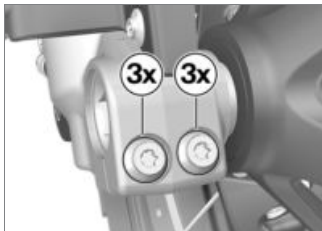

Pinch bolt on quick-release axle

Tightening sequence: Tighten the screws 6 times, alternating between one and the other each time

14 lb/ft (19 Nm)

- Remove the front wheel stand.
- Place right-hand brake caliper on the brake disc.

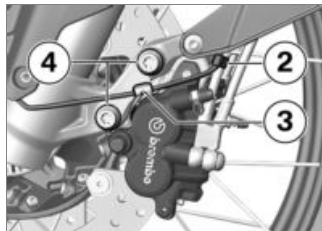

- Tighten the mounting bolts **4** of the left and right brake caliper using an appropriate torque.



Brake caliper on telescopic forks

28 lb/ft (38 Nm)

- Remove adhesive tape from wheel rim.



### WARNING

**Brake pads do not contact the brake disc**

Risk of accident due to delayed braking effect.

- Before driving off, check that the braking effect kicks in without any delay. ◀
- Engage the brake repeatedly, continuing until the brake pads seat against the rotors.
- Insert the wheel speed sensor cable into the holding clips **2** and **3**.



- Insert the wheel speed sensor into the bore and tighten the screw **1** using an appropriate torque.

 Wheel speed sensor at front on fork

Thread-locking compound:  
micro-encapsulated

6 lb/ft (8 Nm)

 Front wheel cover on telescopic forks

2 lb/ft (3 Nm)

## Removing the rear wheel

- Make sure ground is level and firm and put the motorcycle up on a suitable auxiliary stand.
  - with center stand<sup>OE</sup>
- Put the motorcycle up on the center stand, ensuring that it is resting on a firm and level support surface.<

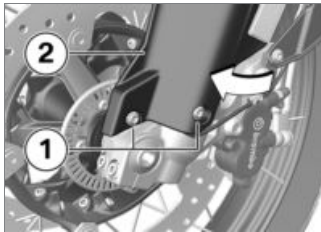

- Move lower part of the front wheel cover **2** into position.
- Install screws **1**.

 Front wheel cover on telescopic forks

Thread-locking compound:  
micro-encapsulated

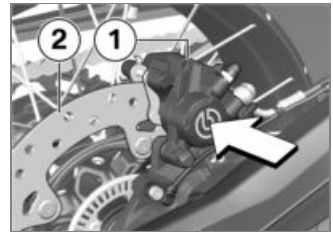

- Press the brake caliper **1** against the brake disk **2**.
  - » Brake pistons are pressed back.

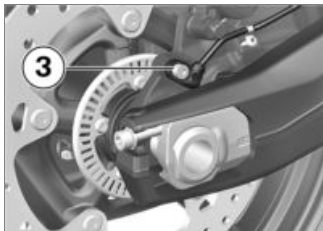

- Remove the screw **3** and remove the wheel speed sensor from the bore.

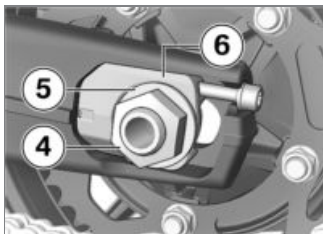

- Remove the axle nut **4** and washer **5**.

- Remove chain tensioner **6** and push axle in as far as possible.

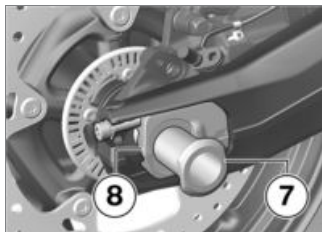

- Remove the quick-release axle **7** and remove the chain tensioner **8**.

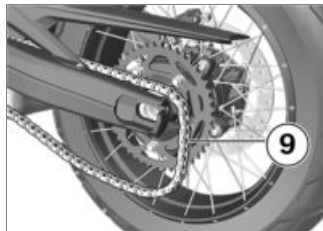

- Roll rear wheel as far forward as possible and disengage chain **9** from chain sprocket.
- Roll rear wheel toward rear out of swinging arm.

#### NOTICE

The camshaft sprocket and the spacing bushings on the left and right are loosely inserted in the wheel. During removal, make sure that the parts are not damaged or lost. ◀

## Installing rear wheel

### WARNING

#### Use of a wheel which does not comply with series specifications

Malfunctions during control interventions by ABS and ASC

- Please see the information on the effect of wheel sizes on the ABS and ASC chassis control systems at the beginning of this chapter. ◀

### ATTENTION

#### Tightening of screwed connections with incorrect tightening torque

Damage or loosening of screwed connections

- Always have the tightening torques checked by a specialized workshop, preferably an authorized BMW Motorrad retailer. ◀

- Roll the rear wheel into the swinging arm and guide the brake disc between the brake pads while doing so.

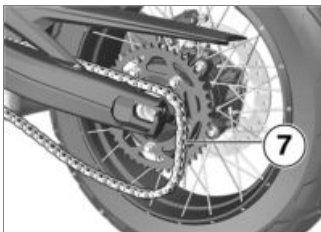

- Roll rear wheel as far forward as possible and place chain **7** on the chain sprocket.

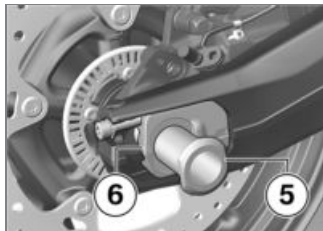

- Insert right chain tensioner **6** into swinging arm, install quick-release axle **5** in brake-caliper support and rear wheel.
- Make sure that the axle fits into the recess of the chain-tensioner.

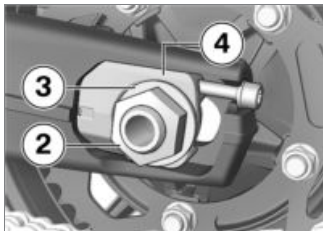

- Insert chain tensioner, left **4**.
- Install washer **3** and axle nut **2**, but do not tighten yet.

– without center stand<sup>OE</sup>

- Remove the auxiliary stand.◁



- Insert the wheel speed sensor into the bore and tighten the screw **1** using an appropriate torque.



Rear wheel speed sensor  
on the brake caliper carrier

Thread-locking compound:  
micro-encapsulated

6 lb/ft (8 Nm)



**WARNING**

**Brake pads do not contact  
the brake disc**

Risk of accident due to delayed braking effect.

- Before driving off, check that the braking effect kicks in without any delay.◀
- After this work is complete, engage the brake repeatedly, continuing until the brake pads seat against the discs.
- Adjusting chain sag (▶▶ 211).

## Air filter

### Removing air cleaner

- Remove the tank cover (▶▶ 203).

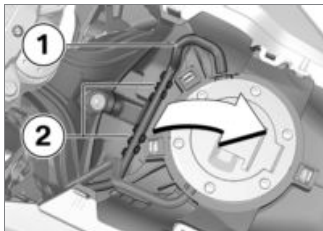

- Unclip hose **1** from retaining lugs **2**.

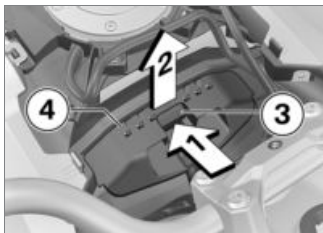

- To unlock it, press and hold button **3** (**arrow 1**).
- Remove frame **4** from the bracket (**arrow 2**).

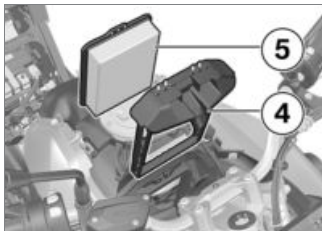

- Remove frame **4**.
- Remove air filter element **5**.

### Installing the air filter

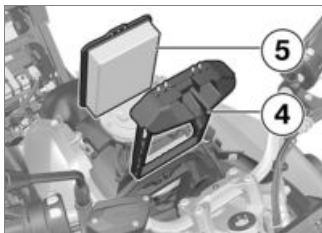

- Install the air filter **5** in the frame **4**.

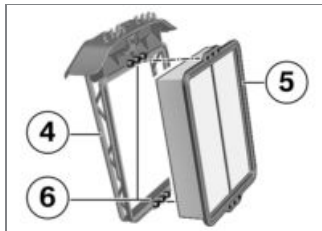

- Make sure that the air filter **5** is attached to the lugs **6** on the frame **4** correctly.

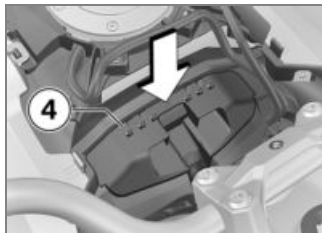

- Install frame **4**.

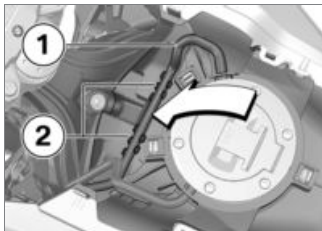

- Clip hose **1** into retaining lugs **2**.

## Light sources

### Replacing the LED for lowbeam headlights and high beams

- The LED lowbeam headlight and the LED high beam can only be replaced as a whole unit. For details please contact a specialist service facility, preferably an authorized BMW Motorrad Retailer.

### Replacing the LED for the parking lights

- The LED side light can only be replaced as a whole unit. For details please contact a specialist service facility, preferably an authorized BMW Motorrad Retailer.

### Replacing LED for brake and rear light

- The LED tail light can only be replaced as a unit. For details please contact a specialist service facility, preferably an authorized BMW Motorrad Retailer.

### Replacing front and rear turn indicator light sources

- Park motorcycle, ensuring that support surface is firm and level.
- Turn off ignition.



- Remove screw **1**.



- Pull glass on screw connection side out of mirror housing.

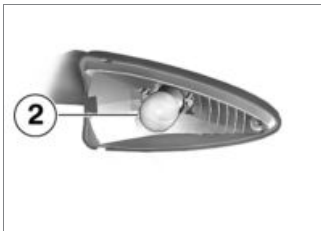

- Remove light source **2** from the light housing by turning it counterclockwise.
- Replace defective light source.

 Bulbs for flashing turn indicators, front

RY10W / 12 V / 10 W

- To protect glass on new bulb against contamination, always use a clean, dry cloth to hold it; do not touch with bare fingers.

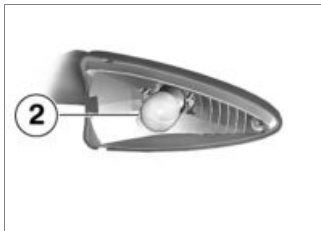

- Install light source **2** by turning clockwise in light housing.



- Insert inside end of lens into light housing and close it.



- Install screw **1**.

### Replacing the license-plate bulb

- Park motorcycle, ensuring that support surface is firm and level.
- Turn off ignition.

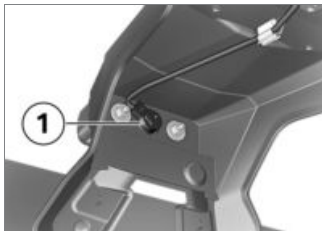

- Remove bulb socket **1** from bulb support.



- Pull bulb out of socket.
- Replace defective bulb.



Light source for license plate light

W5W 12 V 5 W

- To prevent contaminants from being deposited on the new bulb's glass surface, always use a clean, dry cloth to hold it.



- Insert bulb in socket.

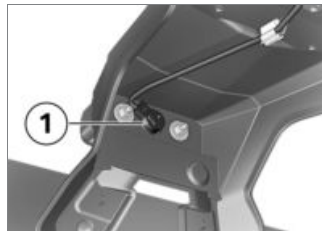

- Insert bulb socket **1** into bulb holder.

### Replacing auxiliary headlights

- with LED additional headlight<sup>OA</sup>
- An auxiliary headlight can only be replaced as a unit. For details please contact a specialist service facility, preferably an authorized BMW Motorrad Retailer.

## Trim panel components

### Remove the tank cover

- Removing seat (➡ 106).



- Remove screws **1** on left and right.
- Remove screws **2**.
- Take off tank cover **3**.

### Refitting fuel tank cover

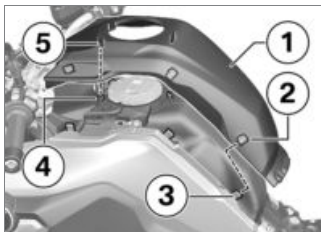

- Ensure that the six holders **2** in the retaining collar **3** and the four sockets **5** in the mounting brackets **4** lock into place.
- Refitting fuel tank cover **1**.

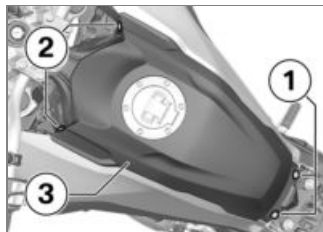

- Install screws **2**.
- Install screws **1**.
- Installing seat (➡ 107).

### Jump-starting



#### ATTENTION

#### Current too high when jump-starting the motorcycle

Cable fire or damage to the motorcycle electronics

- Do not jump-start the motorcycle using the power socket, only via the battery terminal.◀

## ATTENTION

### Contact between crocodile clips of jump leads and motorcycle

Danger of short circuit

- Use jump leads fitted with fully insulated crocodile clips at both ends.◀

## ATTENTION

### Jump-starting with a voltage higher than 12 V

Damage to the motorcycle's electronics

- The battery of the donor motorcycle must have a voltage of 12 V.◀
- Removing seat (➡ 106).
- When jump-starting the engine, do not disconnect the battery from the on-board electrical system.

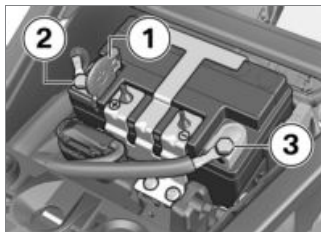

- Press down locking mechanism and open positive terminal cover **1**.
- Begin by connecting one end of the red jump lead to the positive terminal of the discharged battery and the other end to the positive terminal of the donor battery (positive terminal on this vehicle: Position **2**).
- Then connect one end of the black jump lead to the negative terminal of the donor battery and the other end to the negative terminal of the discharged

battery (negative terminal on this vehicle: Position **3**).

## NOTICE

As an alternative to the negative battery terminal, the spring strut bolt can also be used.◀

- Run the engine of the donor vehicle during jump-starting.
- Start the engine of the vehicle with the discharged battery in the usual way; if the engine does not start, wait a few minutes before repeating the attempt in order to protect the starter motor and the donor battery.
- Allow both engines to idle for a few minutes before disconnecting the jump leads.
- Disconnect the jump lead from the negative terminals first, then disconnect the second lead from the positive terminals.

## NOTICE

To start the engine, do not use start sprays or similar items. ◀

- Installing seat (➡ 107).

## Battery

### Maintenance instructions

Correct battery maintenance combined with proper charging and storage procedures extends the battery's service life, and is also required for warranty claims. Compliance with the points below is important in order to maximize battery life:

- Keep the surface of the battery clean and dry.
- Do not open the battery.
- Do not top up with water.
- Be sure to read and comply with the instructions for charging the battery on the following pages.

- Do not turn the battery upside down.

## ATTENTION

### Discharging of the connected battery by the vehicle electronics (e.g. clock)

Total discharge of battery leading to a rejection of warranty claims

- During riding breaks of more than 4 weeks, connect a trickle-charger to the battery. ◀

## NOTICE

BMW Motorrad has developed a trickle-charger specially designed for compatibility with the electronics of your motorcycle. Using this charger, you can keep the battery charged during long periods when the motorcycle is not being used without having to disconnect the battery from the motorcycle's onboard systems. Ad-

ditional information is available at your authorized BMW Motorrad retailer. ◀

### Charging connected battery

- Remove devices connected to onboard power sockets.

## ATTENTION

### Charging the battery connected to the vehicle using the battery terminals

Damage to the motorcycle's electronics

- Disconnect the battery before charging on the battery terminals. ◀

## ATTENTION

### Unsuitable chargers connected to the power socket

Damage to charger and vehicle electronics

- Use suitable BMW chargers. The correct charger is available through your authorized BMW Motorrad retailer.◀



### ATTENTION

**A fully discharged battery must be charged via a power socket or extra socket.**

Damage to vehicle electronics

- A fully discharged battery (battery voltage less than 12 V, indicator lights and multifunction display remain off when ignition is switched on) must always be charged directly at the poles of the **disconnected** battery.◀
- Charge disconnected battery via onboard socket.



### NOTICE

The motorcycle's onboard electronics know when the battery is fully charged. The onboard

socket is switched off when this happens.◀

- Comply with operating instructions of charger.



### NOTICE

If you are unable to charge the battery via the onboard socket, you may be using a charger that is not compatible with your motorcycle's electronics. In this case, charge the battery directly from the terminals of the battery disconnected from the vehicle.◀

### Charge disconnected battery

- Charge battery using a suitable charger.
- Comply with operating instructions of charger.
- After charging, remove the pole terminals from the battery poles.



### NOTICE

In the case of longer periods when the motorcycle is not being used, the battery must be recharged regularly. See the instructions for caring for your battery. Always fully recharge the battery before returning it to use.◀

### Removing battery

- Removing seat (▶▶ 106).
- Park motorcycle. Ensure that the ground is firm and level.
  - with anti-theft alarm system (DWA)<sup>OE</sup>
- Switch off anti-theft alarm if necessary.◀
- Switch off ignition.

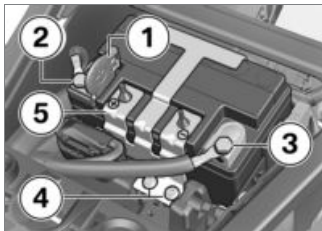

### ATTENTION

#### Incorrect battery disconnection

Danger of short circuit

- Follow the disconnection sequence. ◀
- First, remove the negative battery cable **3**.
- Push in the lock and open the positive terminal cover **1**.
- Then, remove the positive battery cable **2**.
- Remove screws **4** on the left and right and take off battery

carrier **5** forward from the battery.

- Lift battery up and out, using tilting movements if the movement is stiff.

#### Installing battery

### NOTICE

If the vehicle has been disconnected from the battery for a long time, the current date must be entered in the instrument cluster to make sure the service display is working properly. ◀

- Switch off ignition.
- Insert battery into battery compartment with positive terminal on right in driving direction.



- Fit battery carrier **5**.
- Install screws **4** on left and right.
- Push in the locking mechanism and open the positive terminal cover **1**.

### ATTENTION

#### Incorrect battery connection

Danger of short circuit

- Follow the installation sequence. ◀
- Install positive battery cable **2**.
- Close positive terminal cover **1**.

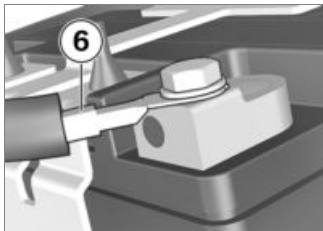

- Install the negative battery cable **3** in alignment with **6**, making sure there is a sufficient distance between the negative battery cable and the seat locking lever.

- with anti-theft alarm system (DWA)<sup>OE</sup>
- If necessary, switch on anti-theft alarm system.◀
- Installing seat (▣▶ 107).
- Set clock (▣▶ 86).

## Fuses

### Replace main fuse



#### ATTENTION

#### Bypassing defective fuses

Risk of short circuit and fire

- Do not bypass defective fuses.
- Replace defective fuses with new fuses.◀
- Switch off the ignition.
- Place the motorcycle on its stand on firm, even ground.
- Removing seat (▣▶ 106).



- Replace faulty fuse **1**.



#### NOTICE

If the fuses blow frequently, have the electrical system checked by an authorized specialized workshop, preferably an authorized BMW Motorrad retailer.◀



Main fuse

40 A (Voltage regulator)

- Installing seat (▣▶ 107).

### Replace fuses

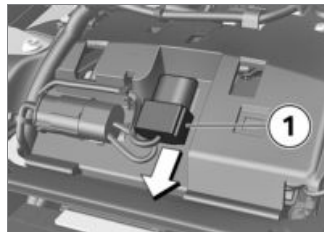

- Switch off the ignition.

- Removing seat (➡ 106).
- Pull off connector **1**.



## ATTENTION

### Bypassing defective fuses

Risk of short circuit and fire

- Do not bypass defective fuses.
- Replace defective fuses with new fuses.◀
- Replace faulty fuse **1** or **2** according to layout.



## NOTICE

If the fuses blow frequently, have the electrical system checked by

an authorized specialized workshop, preferably an authorized BMW Motorrad retailer.◀



Fuse box

10 A (Slot 1: instrument cluster, anti-theft alarm system (DWA), ignition lock, diagnostic socket, coil main relay)

7.5 A (Slot 2: left multifunction switch, Tire Pressure Control (TPC/RDC))

- Installing seat (➡ 107).

### Diagnostic socket

### Removing the diagnostic connector



## CAUTION

**Incorrect procedure followed when disconnecting the data link connector for the On-Board Diagnostics.**

Motorcycle experiences malfunctions

- Only have the data link connector disconnected by a specialist workshop or other authorized persons during your next BMW Service appointment.
- Have the work performed by appropriately trained staff.
- Refer to the vehicle manufacturer specifications.◀
- Removing seat (➡ 106).



- Press the locking mechanisms **1** on both sides.

- Unplug the data link connector **2** from the bracket **3**.
- » The diagnosis and information system interface can be connected at the data link connector **2**.

## Secure the data link connector

- Disconnect the diagnosis and information system interface.

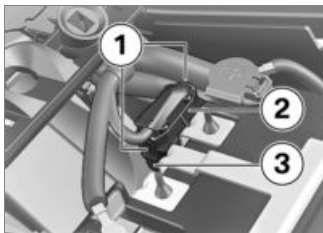

- Plug the seat data link connector **2** into the holder **3**.
- » The locks **1** engage.
- Installing seat (➔ 107).

## Chain Lubricating chain



### ATTENTION

#### Insufficient cleaning and lubrication of the drive chain

Increased wear

- Clean and lubricate the drive chain regularly.◀
- Lubricate drive chain at least every 500 mi (800 km). Perform lubrication at shorter intervals after riding in wet conditions, or after riding in dusty or dirty conditions.
- Switch off ignition and engage Neutral.
- Clean drive chain with suitable cleaning agent, dry and apply chain lubricant.



### NOTICE

BMW Motorrad recommends that you use chain cleaners

and chain lubricants available at your authorized BMW Motorrad retailer.◀

- Wipe off excess lubricant.

## Checking chain sag

- Park motorcycle, ensuring that support surface is firm and level.
- Turn the rear wheel until the position with the lowest chain sag is reached.

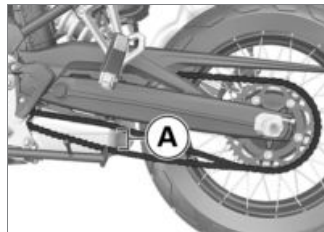

- Using a screwdriver, push chain up and down and measure difference **A**.



Chain sag

1.6...2 in (40...50 mm) (Motorcycle unloaded on side stand)

– with lowered<sup>OE</sup>

1.4...1.8 in (35...45 mm) (Motorcycle unloaded on side stand)◁

If the measured value is outside the approved tolerance:

- Adjusting chain sag (▮▮▮ 211).

### Adjusting chain sag

- Place the motorcycle on its stand on firm, even ground.

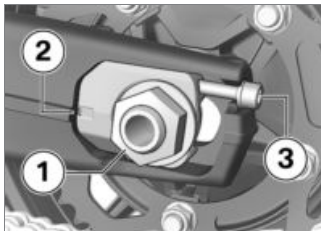

- Loosen axle nut **1**.
- Adjust chain sag using adjusting screws **3** on left and right.
- Checking chain sag (▮▮▮ 210).
- Make sure that the same scale value **2** is set on the left and right.
- Tighten quick-release axle nut **1** to tightening torque.



Rear-wheel quick-release axle in swinging arm

Thread-locking compound: mechanical

74 lb/ft (100 Nm)



- Check whether washer **4** is in full contact with screw head **3** and correct if necessary.

### Check chain wear Requirement

Chain sag is correctly adjusted.

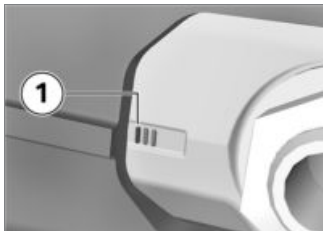

- Park motorcycle. Ensure that the ground is firm and level.
  - Check whether the third marker line **1** is fully visible.
- If the third marker line **1** is fully visible, check the chain length:
- Engage 1st gear.
  - Rotate rear wheel toward front of motorcycle until the chain is tensioned.
- 
- Determine the chain length below the rear wheel swinging arm across the center of 10 rivets.
  - Turn the rear wheel in the direction of travel and calculate

the chain length at 3 different spots.

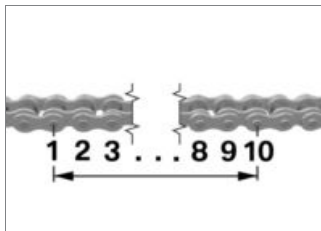

Permissible chain length

max 5.7 in (max 144 mm)  
(measured over the **center**  
of 10 rivets, chain under tension)

If the chain has reached the maximum approved length:

- Contact a specialist workshop, preferably an authorized BMW Motorrad retailer.

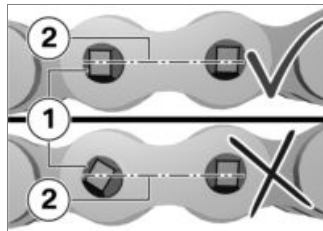

- Check to see whether a rivet head **1** has rotated.
- Rivet heads should be parallel to the centerline of the chain **2**.
- Riveting is OK.

If one or more rivet heads has rotated:

- Contact a specialist workshop, preferably an authorized BMW Motorrad retailer.

## **Accessories**

General notes.....	214
Onboard power outlets .....	214
Case.....	215
Topcase .....	218
Navigation system .....	222

## General notes

### CAUTION

#### Use of products from other manufacturers

##### Safety risk

- BMW Motorrad cannot examine or test each product of outside origin to ensure that it can be used on or in connection with BMW motorcycles without constituting a safety hazard. Nor is this guarantee provided when the official approval of a specific country has been granted. Tests conducted by these instances cannot make provision for all operating conditions experienced by BMW motorcycles and, consequently, they are not sufficient in some circumstances.
- Use only parts and accessories approved by BMW for your motorcycle. ◀

The safety, operation and suitability of the parts and accessory products have been thoroughly tested by BMW. Therefore, BMW assumes responsibility for these products. BMW shall not be held liable for unapproved parts and accessory products of any kind. Comply with legal requirements for any modifications. The motorcycle shall not violate the regulations governing motorcycle approval for highway use applicable in your own country. Your BMW Motorrad retailer offers you expert advice when choosing genuine BMW parts, accessories and other products. More information on the topic of accessories is available at: [bmw-motorrad.com/equipment](http://bmw-motorrad.com/equipment)

## Onboard power outlets

Information on using onboard power sockets:

### Automatic deactivation

Power outlets are switched off automatically in the following circumstances:

- If the battery is too low to start the vehicle.
- If the maximum load specified in the technical data is exceeded.
- During the starting procedure.

### Operating electrical accessories

The ignition must be switched on before any accessories connected to the power sockets can be operated. If the ignition is then switched off, the accessory remains in operation. The sockets are switched off approx. 15 minutes after switching off

the ignition to reduce the strain on the onboard electrical system. Accessories with low power consumption are possibly not detected by the vehicle electronics. In these cases, onboard sockets are already switched off shortly after the ignition is switched off.

### Cable routing

Observe the following when routing cable from power sockets to additional devices:

- Cables must not hinder the rider's movement.
- Cables must not restrict the steering angle and driving characteristics.
- Cables must not become trapped.

## Case

### Open case

– with case<sup>OA</sup>

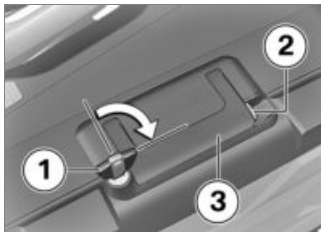

- Turn key **1** clockwise.
- Press and hold yellow locking mechanism **2** and open handle **3**.



- Press yellow button down **1** and open case cover at the same time.

### Adjusting case volume

- with case<sup>OA</sup>
- Open case and empty it.



- Engage swivel arm **1** into its upper end position to obtain the smallest volume.
- Engage swivel arm **1** into its lower end position to obtain the largest volume.
- Close case.



Case volume, left

6.6...9.2 gal (25...35 l)



Case volume, right

4...6.1 gal (15...23 l)

## Close case

– with case<sup>OA</sup>

- Turn key in case lock transversely to the direction of travel.
  - Close case lid.
- » The lid clicks audibly into place.

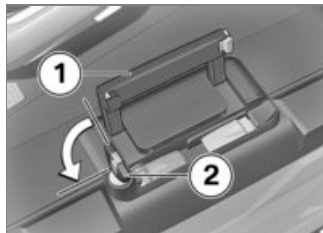

## ATTENTION

### Folding down the carrying handle when the case is locked

Damage to the locking tab

- Before folding down the carrying handle, make sure that

the slot of the case lock is perpendicular to the direction of travel. ◀

- Shut carrying handle **1**.
- Turn key **2** counterclockwise and remove.

## Remove case

– with case<sup>OA</sup>

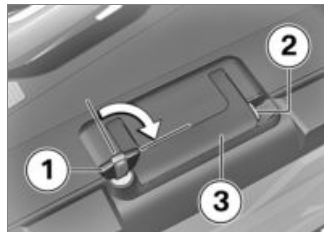

- Turn the ignition key **1** clockwise.
- Press and hold yellow locking mechanism **2** and open carrying handle **3**.



- Pull up red release lever **1**.
- » Locking mechanism **2** springs open.
- Fully open locking mechanism.
- Remove case on the carrying handle from the bracket.



- Pull up red release lever **1**.
- » Locking mechanism **2** springs open.
- Fully open locking mechanism.

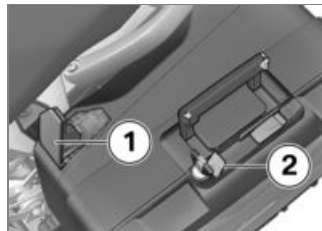

- Push locking mechanism **1** down until you feel resistance.
- Then push down locking mechanism and red release lever **2** at the same time.
- » Locking mechanism engages.

## Mounting case

– with case<sup>OA</sup>

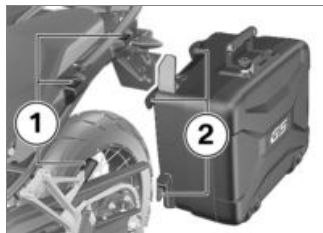

- Insert case from above into brackets **1** and **2**.

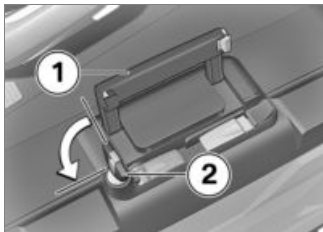

## ATTENTION

### Folding down the carrying handle when the case is locked

Damage to the locking tab

- Before folding down the carrying handle, make sure that the slot of the case lock is perpendicular to the direction of travel. ◀
- Shut carrying handle **1**.
- Turn key **2** counterclockwise and remove.

### Maximum payload and maximum speed

Observe the maximum payload and maximum speed for riding with cases fitted, as indicated on the sign inside the case.

If you cannot find your combination of vehicle and case on the sign, contact your BMW Motorrad retailer.

The following values apply for the combination described here:



Maximum speed for riding with case

max 99 mph (max 160 km/h)



Payload per case

max 18 lbs (max 8 kg)

### Topcase

#### Open topcase

– with topcase<sup>OA</sup>

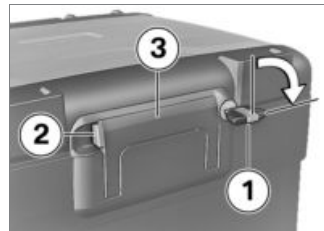

- Turn key **1** clockwise.
- Press and hold yellow locking mechanism **2** and open handle **3**.



- Push forward yellow button **1** and open topcase cover at the same time.

### Adjust topcase volumes

– with topcase<sup>OA</sup>

- Open topcase and empty it.



- Lock swivel arm **1** into its most forward position to obtain the largest volume.
- Lock swivel arm **1** as far back as it goes to obtain the smallest volume.
- Close topcase.

### Close topcase

– with topcase<sup>OA</sup>

- Close topcase cover forcefully.

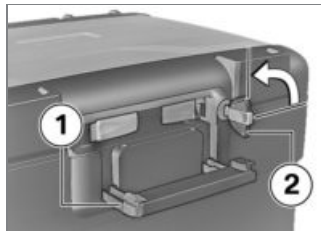

### **ATTENTION**

#### Folding down the carrying handle when the case is locked

Damage to the locking tab

- Before folding down the carrying handle, make sure that the slot of the topcase lock is vertical. ◀
- Shut carrying handle **1**.  
» Carrying handle audibly engages.
- Turn key **2** counterclockwise and remove.

## Remove topcase

– with topcase<sup>OA</sup>

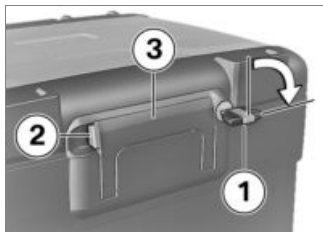

- Turn key **1** clockwise.
- Press and hold yellow locking mechanism **2** and open handle **3**.

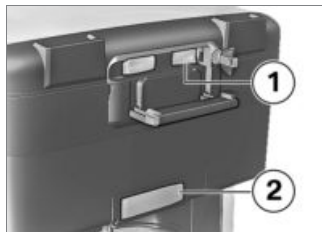

- Pull back red lever **1**.
- » Locking mechanism **2** springs open.
- Fully open locking mechanism.
- Remove topcase on the carrying handle from the bracket.

## Mount topcase

– with topcase<sup>OA</sup>

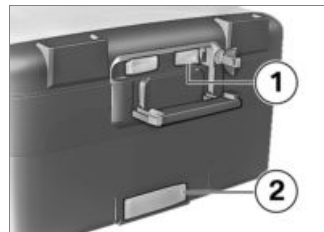

- Pull back red lever **1**.
- » Locking mechanism **2** springs open.
- Fully open locking mechanism.



- Mount topcase onto the front brackets **1** of the topcase mounting plate.
- Push topcase back on the topcase mounting plate.



- Push locking mechanism **1** forward until you feel resistance.
- Then push forward locking mechanism and red release lever **2** at the same time.
  - » Locking mechanism engages.

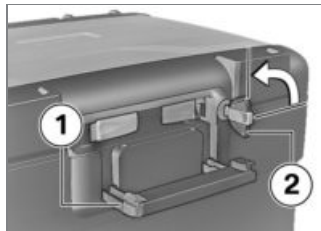

### **ATTENTION**

#### **Folding down the carrying handle when the case is locked**

Damage to the locking tab

- Before folding down the carrying handle, make sure that the slot of the topcase lock is vertical. ◀
- Shut carrying handle **1**.
  - » Carrying handle audibly engages.
- Turn key **2** counterclockwise and remove.

## Maximum payload and maximum speed

Observe the maximum payload and maximum speed for riding with topcase fitted, as indicated on the sign inside the topcase. If you cannot find your combination of vehicle and topcase on the sign, contact your authorized BMW Motorrad retailer. The following values apply for the combination described here:



Maximum speed when riding with a loaded topcase

max 99 mph (max 160 km/h)



Payload of Topcase

max 11 lbs (max 5 kg)

## Navigation system

– with preparation for navigation system<sup>OE</sup>

### Securely fasten navigation device



#### NOTICE

The navigation preparation is suitable as from the BMW Motorrad Navigator IV.◀



#### NOTICE

The locking system of the Mount Cradle offers no protection against theft. Remove the navigation system and store in a safe place after every drive.◀

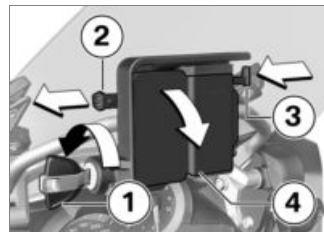

- Turn the ignition key **1** counterclockwise.
- Pull the shut-off lock **2** to the **left**.
- Press in the locking mechanism **3**.
- » The Mount Cradle is unlocked and the cover **4** can be removed with a rotational movement toward the front.

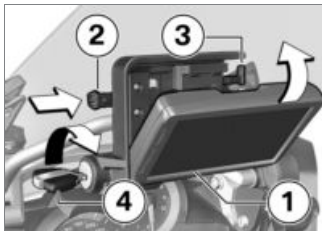

## Removing the navigation device and installing the cover panel

### ATTENTION

#### Dust and dirt on the contacts of the Mount Cradle

Damage to the contacts

- Reinstall the cover after end of each drive. ◀

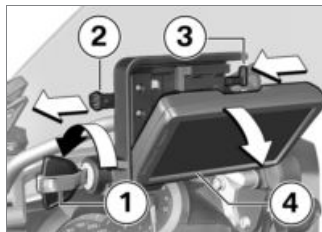

- Turn the ignition key **1** counterclockwise.
- Pull the shut-off lock **2** completely to the **left**.

- » The locking mechanism **3** is unlocked.
- Slide the locking mechanism **3** completely to the **left**.
- » Navigation device **4** is unlocked.
- Remove navigation device **4** downward with a tilting movement.

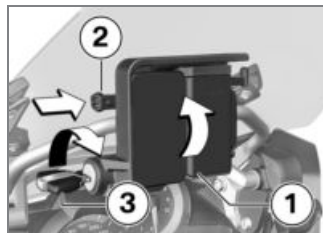

- Mount the cover **1** in the lower area and swing upward with a rotational movement.
- » Cover audibly engages.
- Slide the shut-off lock **2** to the **right**.

- Turn the ignition key **3** clockwise.
- » The cover **1** is secured.

## Operating the navigation system

### NOTICE

The following description refers to the BMW Motorrad Navigator V and the BMW Motorrad Navigator VI. The BMW Motorrad Navigator IV does not offer all options described. ◀

### NOTICE

Only the latest version of the BMW Motorrad communication system is supported. A software update may be required for the BMW Motorrad communication system. In this case, please contact your authorized BMW Motorrad retailer. ◀

Some of the BMW Motorrad Navigator functions can be operated directly from the handlebars if it is installed and the operating focus is changed to the Navigator (▶ 115).

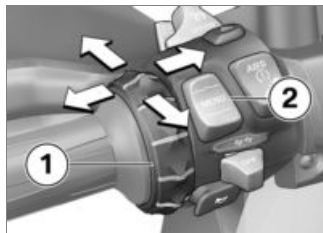

The navigation system is operated using the Multi-Controller **1** and the rocker button MENU **2**.

### Turn the Multi-Controller 1 upwards and downwards

On the compass and Mediaplayer pages: increase or reduce the volume for a

BMW Motorrad communication system connected via Bluetooth. On the BMW special menu: Select menu items.

### Briefly tilt the Multi-Controller 1 to the left and to the right

Switch between the main pages of the Navigator:

- Map view
- Compass
- Mediaplayer
- BMW special menu
- My motorcycle page

### Tilt and hold the Multi-Controller 1 to the left and to the right

Activate certain functions on the Navigator display. These functions are marked with a right arrow or a left arrow above the corresponding touch field.



The function is triggered by long actuation to the right.



The function is triggered by long actuation to the left.

### Press the rocker button MENU 2 down

Switch the operating focus to the Pure Ride view.

In detail, the following functions can be operated:

#### Map view

- Turning upwards: Zooms in to map section (Zoom in).
- Turning downwards: Zooms out of map section (Zoom out).

#### BMW special menu

- Speak: Repeat last navigation announcement.
- Waypoint: Save current location as a favorite.

- Navigate home: Starts navigation to the home address (is grayed-out if no home address is set).
- Mute: Switch automatic navigation announcements off or on (off: the top line in the display shows a crossed-out lip symbol). Navigation announcements can still be output via "Speak". All other sound outputs remain switched on.
- Switching off display: Switch off display.
- Call home: Calls the phone number stored in the navigator (only displayed when a phone is connected).
- Detour: Activates the detour function (only displayed if a route is active).
- Skip: Skips the next way point (only displayed if route is provided with way points).

### My Motorcycle

- Turning: Changes the number of the displayed data.
- Touching a data field on the display opens a menu for selecting the data.
- The values available for selection depend on the optional equipment that is installed.



#### NOTICE

The Mediaplayer function is only available when using a Bluetooth device as per A2DP standard, e.g., a BMW Motorrad communication system. ◀

#### Mediaplayer

- Long press to the left: Play previous title.
- Long press to the right: Play the next title.
- Turning increases or reduces the volume of a BMW Motorrad communication

system connected via Bluetooth.

## Warning and status messages



Warning and status messages of the motorcycle are indicated with a corresponding symbol **1** at the upper left on the map view.

### NOTICE

If a BMW Motorrad communication system is connected, an acoustic signal is also sounds in case of a warning. ◀

If several warning messages are active, the number of messages is indicated below the warning triangle.

A list of all warning messages is opened by pressing on the warning triangle with more than one message.

Additional information is display when a message is selected.

### NOTICE

Detailed information cannot be displayed for all warnings. ◀

## Special functions

Due to integration of the BMW Motorrad Navigator there are differences from the descriptions in the instruction manual for the Navigator.

### Reserve fuel level warning

The settings for the fuel gage are not available because the reserve warning is transmitted from the

vehicle to the Navigator. If the message is active, the nearest gas stations are shown when you press on the message.

## Time and date display

The Navigator transmits the time display and date to the motorcycle. In order to adopt the time in the TFT display, in the menu Settings, System settings, Date and time the function GPS synchronization also needs to be activated.

## Security settings

The BMW Motorrad Navigator V and the BMW Motorrad Navigator VI can be secured against unauthorized use with a four-digit PIN (Garmin Lock). When this function is activated, once the Navigator GPS receiver is cradled on the motorcycle and the ignition is switched on you will receive a prompt asking whether

the motorcycle should be added to the list of secure vehicles. If you confirm this question by answering "yes", the Navigator will save the vehicle identification number of this vehicle.

A maximum of five VINs can be saved in this way.

A PIN entry will no longer be required when this Navigator is activated by turning on the ignition switch in any of these vehicles.

Removing the Navigator from the motorcycle while it is switched on will launch a new PIN request as a security measure.

### **Screen brightness**

Screen brightness is adjusted by the motorcycle while the unit is cradled. There is no need for manual input.

If desired, automatic setting can be switched off in the Navigator via the display settings.



## Care

Care products .....	230
Washing your motorcycle .....	230
Cleaning sensitive motorcycle parts .....	231
Paint care .....	232
Protective wax coating .....	232
Store motorcycle .....	232
Return motorcycle to use .....	233

## Care products

BMW Motorrad recommends that you use cleaning and care products available at your authorized BMW Motorrad retailer. BMW Care Products have been materials tested, laboratory tested, and field tested and provide optimum care and protection for the materials used in your vehicle.



### ATTENTION

#### Use of unsuitable cleaning and care agents

Damage to motorcycle parts

- Do not use any solvents such as nitro thinners, cold cleaners, fuel or similar, and do not use cleaning agents that contain alcohol. ◀



### ATTENTION

#### Use of highly acidic or alkaline cleaning agents

Damage to motorcycle parts

- Observe the dilution ratio on the packaging of the cleaning agents.
- Do not use highly acidic or alkaline cleaning agents. ◀

#### Washing your motorcycle

BMW Motorrad recommends that you use BMW Insect Remover to soften and wash off insects and stubborn dirt from painted parts before washing the motorcycle.

To prevent stains, do not wash the motorcycle immediately after it has been exposed to bright sunlight and do not wash it in the sun.

Make sure that the motorcycle is washed frequently, especially during the winter months. To remove road salt, clean the motorcycle with cold water immediately after completion of every trip.



### WARNING

#### Damp brake disks and brake pads after washing the motorcycle, after riding through water or in the rain

Poorer braking action, accident hazard

- Brake early until the brake rotors and brake pads are dry. ◀



### ATTENTION

#### Increased effect of salt caused by warm water

Corrosion

- Only use cold water to remove road salt. ◀



## ATTENTION

### Damage caused by high water pressure from high-pressure cleaners or steam-jet devices

Corrosion or short circuit, damage to labels, to seals, to hydraulic brake system, to the electrical system and the seat

- Exercise caution when using high-pressure or steam-jet devices. ◀

## Cleaning sensitive motorcycle parts

### Plastics



## ATTENTION

### Use of unsuitable cleaning agents

Damage to plastic surfaces

- Do not use abrasive cleaners or cleaners containing alcohol or solvents.
- Do not use insect sponges or sponges with a hard surface. ◀

### Fairings and panels

Clean trim panel components with water and BMW Motorrad solvent cleaner.

### Windshields and lenses are manufactured in plastic

Clean off dirt and insects with a soft sponge and plenty of water.



## NOTICE

Soften stubborn dirt and dead insects by covering the affected areas with a wet cloth. ◀

### TFT display

Clean the TFT display with warm water and detergent. Then dry with a clean cloth, e.g. a paper towel.

## Chrome

Carefully clean chrome parts with plenty of water and BMW Motorrad Care Products motorcycle cleaner. This is particularly important in the case of road salt.

Use BMW Motorrad metal polish for additional treatment.

## Radiator

Clean the radiator regularly to prevent overheating of the engine due to inadequate cooling. For example, use a garden hose with low water pressure.



## ATTENTION

### Bending of radiator fins

Damage to radiator fins

- When cleaning, ensure that the cooler fins are not bent. ◀

## Rubber

Treat rubber components with water or BMW rubber protection coating agent.



### ATTENTION

#### Use of silicone sprays for care of rubber seals

Damage to rubber seals

- Do not use silicone sprays or care products that contain silicone. ◀

## Paint care

Washing the motorcycle regularly will help counteract the long-term effects of substances that damage the paint, especially if your motorcycle is ridden in areas with high air pollution or natural sources of dirt, such as tree resin or pollen.

At the same time, you should remove particularly aggressive materials immediately; otherwise

changes in the paint and discoloration can occur. These include spilled fuel, oil, grease and brake fluid as well as bird droppings. It is recommended to use BMW Motorrad solvent cleaner and then apply BMW Motorrad high gloss polish to preserve the paint.

Contamination on the paint finish is particularly easy to see after the motorcycle has been washed. Remove this type of soiling with cleaning naphtha or spirit on a clean cloth or cotton ball. BMW Motorrad recommends removing tar stains with BMW tar remover. Then add a protective wax coating to the paint at these locations.

## Protective wax coating

Apply a preservative when water fails to bead up on the painted surface.

BMW Motorrad recommends BMW Motorrad high gloss polish or agents that contain carnauba or synthetic wax to protect the paint finish.

## Store motorcycle

- Clean motorcycle.
- Completely fill the motorcycle's fuel tank.
- Removing battery (▶▶▶ 206).
- Spray the brake and clutch lever, and the center and side stand pivots with a suitable lubricant.
- Preserve bare metal and chrome-plated parts with an acid-free grease (Vaseline).
- Park motorcycle in a dry room, raising it to remove weight from both wheels (preferably using the front-wheel and

rear-wheel stands offered by BMW Motorrad).

## **Return motorcycle to use**

- Remove the protective wax coating.
- Clean motorcycle.
- Installing battery (➡ 207).
- Observe checklist (➡ 147).



## Technical data

Troubleshooting chart .....	236
Screw connections .....	239
Fuel.....	241
Engine oil .....	241
Engine .....	242
Clutch .....	243
Transmission .....	243
Rear-wheel drive.....	244
Frame .....	244
Chassis .....	244
Brakes .....	245
Wheels and tires .....	246
Electrical system.....	248
Dimensions .....	250
Weights.....	251

Performance data .....	252
------------------------	-----

## Troubleshooting chart

Engine does not start:

<b>Possible cause</b>	<b>Remedy</b>
Side stand extended and gear engaged	Engage neutral or fold in side stand.
Gear engaged and clutch not operated	Place transmission in neutral or disengage clutch.
No fuel in tank	Refueling.
Battery drained	Charging connected battery.
Overheating protection for starter motor has activated. Starter motor can only be actuated for a limited period.	Leave the starter motor to cool down for around 1 minute until it becomes available again.

Bluetooth connection is not established.

### **Possible cause**

### **Remedy**

Necessary pairing steps were not performed.

Refer to the operating instructions of the communication system for the necessary steps for pairing.

The communication system is not connected automatically despite successful pairing.

Switch off the communication system of the helmet and connect again after one to two minutes.

Too many Bluetooth devices are stored in the helmet.

Delete all pairing entries in the helmet (see the operating instructions of the communication system).

There are additional vehicles with Bluetooth-capable devices nearby.

Avoid simultaneous pairing with multiple vehicles.

Bluetooth connection is disrupted.

### **Possible cause**

### **Remedy**

Bluetooth connection to the mobile end device is interrupted.

Switch off energy saving mode.

Bluetooth connection to the helmet is interrupted.

Switch off the communication system of the helmet and connect again after one to two minutes.

Volume in the helmet cannot be adjusted.

Switch off the communication system of the helmet and connect again after one to two minutes.



## Screw connections

Front wheel	Value	Valid
<b>Wheel speed sensor at front on fork</b>		
M6 x 16, Renew bolt micro-encapsulated	6 lb/ft (8 Nm)	
<b>Front wheel cover on telescopic forks</b>		
M6 x 16, Renew bolt micro-encapsulated	2 lb/ft (3 Nm)	
<b>Brake caliper on telescopic forks</b>		
M10 x 45	28 lb/ft (38 Nm)	
<b>Pinch bolt on quick-release axle</b>		
M8 x 35	<b>Tightening sequence: Tighten the screws 6 times, alternating between one and the other each time</b>	
	14 lb/ft (19 Nm)	
<b>Axle screw in front quick-release axle</b>		
M20 x 1.5	37 lb/ft (50 Nm)	

<b>Rear wheel</b>	<b>Value</b>	<b>Valid</b>
<b>Rear wheel speed sensor on the brake caliper carrier</b>		
M6 x 16, Renew bolt micro-encapsulated	6 lb/ft (8 Nm)	
<b>Rear-wheel quick-release axle in swinging arm</b>		
M24 x 1.5 mechanical	74 lb/ft (100 Nm)	
<b>Mirror arm</b>	<b>Value</b>	<b>Valid</b>
<b>Mirror (locknut) on clamping piece</b>		
M10 x 1.25	Left-hand thread, 16 lb/ft (22 Nm)	
<b>Adapter to clamping block</b>		
M10 x 14 - 4.8	18 lb/ft (25 Nm)	

## Fuel

Recommended fuel quality	Regular unleaded (max. 15 % ethanol, E15) 87 AKI (91 ROZ/RON) 87 AKI
Tank capacity	Approx. 4 gal (Approx. 15 l)
Reserve fuel quantity	Approx. 3.7 quarts (Approx. 3.5 l)
Fuel consumption	57 mpg (4.1 l/100 km), according to WMTC
CO2 emissions	98 g/km, according to WMTC
Emission standard	Euro 4

## Engine oil

Engine oil, capacity	Approx. 3.2 quarts (Approx. 3.0 l), with filter replacement
Specification	SAE 5W-40, API SJ/JASO MA2, Additives (for instance, molybdenum-based substances) are prohibited, because they would attack the coatings on engine components, BMW Motorrad recommends BMW Motorrad ADVANTEC Ultimate oil.

**BMW recommends** **ADVANTEC**  
ORIGINAL BMW ENGINE OIL

Oil additives

BMW Motorrad does not recommend the use of oil additives, as these can adversely affect the operation of the clutch. Ask your BMW Motorrad retailer for engine oils suitable for your motorcycle.

**BMW recommends** **ADVANTEC**  
ORIGINAL BMW ENGINE OIL

## Engine

Engine number location	Upper right crankcase
Engine type	A24A08A
Engine design	Water-cooled 2-cylinder four-stroke engine with four valves (operated via rocker arms) per cylinder, two overhead camshafts and dry-sump lubrication
Displacement	853 cc (853 cm <sup>3</sup> )
Cylinder bore	3.3 in (84 mm)
Piston stroke	3 in (77 mm)
Compression ratio	12.7:1
Nominal capacity	90 hp (66 kW), at engine speed: 8000 min <sup>-1</sup>
Torque	63 lb/ft (86 Nm), at engine speed: 6250 min <sup>-1</sup>
Maximum engine speed	max 9000 min <sup>-1</sup>
Idle speed	1250 min <sup>-1</sup> , Engine at operating temperature

## Clutch

Clutch design	Multiple-disc oil bath (anti-hopping)
---------------	---------------------------------------

## Transmission

Transmission design	Claw-shifted 6-speed manual gearbox integrated in engine housing
Transmission gear ratios	1.821, Primary gear ratio 1:2.833, 1st gear 1:2.067, 2nd gear 1:1.600, 3rd gear 1:1.308, 4th gear 1:1.103, 5th gear 1:0.968, 6th gear

## Rear-wheel drive

Type of final drive	Chain drive
Type of rear-wheel guide	Two-arm aluminum swinging arm
Number of teeth of rear-wheel drive (Pinion/sprocket)	17/44

## Frame

Frame design	Steel weigh-bridge frame in shell construction
Location of type plate	Frame at front left on steering head
Location of the vehicle identification number	Frame at front right next to steering head

## Chassis

### Front wheel

Type of front suspension	Upside-down telescopic forks
Spring travel, front	9.1 in (230 mm), on front wheel
– with lowered <sup>OE</sup>	8.3 in (210 mm), on front wheel

## Rear wheel

Type of rear-wheel guide	Two-arm aluminum swinging arm
Design of rear-wheel suspension	Central spring strut with coil spring, adjustable rebound-stage damping and spring preload
Spring travel on the rear wheel	8.5 in (215 mm), on rear wheel
– with lowered <sup>OE</sup>	7.7 in (195 mm), on rear wheel

## Brakes

### Front wheel

Type of front wheel brake	Hydraulically operated twin disc brake with 2-piston floating calipers and floating brake discs
Front brake pad material	Sintered metal
Front brake disc thickness	0.18 in (4.5 mm), New min 0.16 in (min 4.0 mm), Wear limit
Free travel of brake actuation (Front wheel brake)	0.03...0.07 in (0.7...1.7 mm), measured at the piston

**Rear wheel**

Type of rear wheel brake	Hydraulically operated disk brake with 1-piston floating caliper and fixed brake disk
Rear brake pad material	Organic
Rear brake disc thickness	0.2 in (5.0 mm), New min 0.18 in (min 4.5 mm), Wear limit
Blow-by clearance of footbrake lever	0.07...0.08 in (1.9...2.1 mm), At the end stop of the foot brake lever on the footrest plate.

**Wheels and tires**

Recommended tire combinations	An overview of the current tire approvals is available from your authorized BMW Motorrad retailer or on the Internet at <a href="http://bmw-motorrad.com">bmw-motorrad.com</a> .
Speed category of front/rear tires	V, minimum requirement: 149 mph (240 km/h)

**Front wheel**

Front wheel design	Cross spoke wheel
Front-wheel rim size	2.15" x 21" MTH2
Front tire designation	90/90-21
Load index for front tire	54
Permissible front-wheel imbalance	max 0.2 oz (max 5 g)
Balance weight for front wheel (Half of each weights must be attached on the right and left of the rim respectively)	max 2.8 oz (max 80 g)

**Rear wheel**

Rear wheel design	Cross spoke wheel
Rear-wheel rim size	4.25" x 17" MTH2
Rear tire designation	150/70 R 17
Load index for rear tire	69
Permissible rear-wheel imbalance	max 1.6 oz (max 45 g)
Balance weight for rear wheel (Half of each weights must be attached on the right and left of the rim respectively)	max 2.8 oz (max 80 g)

**Tire pressure**

Front tire pressure	31.9 psi (2.2 bar), One-up, with cold tires 36.3 psi (2.5 bar), Driver with passenger and/or load, with cold tire
Rear tire pressure	36.3 psi (2.5 bar), One-up, with cold tires 42.1 psi (2.9 bar), Driver with passenger and/or load, with cold tire

**Electrical system**

Main fuse	40 A, Voltage regulator
Fuse box	10 A, Slot 1: instrument cluster, anti-theft alarm system (DWA), ignition lock, diagnostic socket, coil main relay 7.5 A, Slot 2: left multifunction switch, Tire Pressure Control (TPC/RDC)
Fuses	All electrical circuits are electronically protected. If an electric circuit was switched off by the electronic fuse and if the fault that caused this has been rectified, the electric circuit will be active again after switching on the ignition.
Electrical rating of onboard sockets	5 A

**Battery**

Battery design	AGM battery (Absorbent Glass Mat)
Battery voltage	12 V
Battery capacity	10 Ah
Battery type (For Keyless Ride radio-operated key)	
– with Keyless Ride <sup>OE</sup>	CR 2032

**Spark plugs**

Spark plugs, manufacturer and designation	NGK LMAR8J-9E
---	---------------

**Light sources**

Bulb for high-beam headlight	LED
Bulbs for low-beam headlight	LED
Bulb for parking light	LED
Bulb for taillight/brake light	LED
Light source for license plate light	W5W 12 V 5 W
Bulbs for flashing turn indicators, front	RY10W / 12 V / 10 W
Bulbs for flashing turn indicators, rear	RY10W / 12 V / 10 W

## Dimensions

Motorcycle length	90.7 in (2305 mm), over license-plate carrier
– with lowered <sup>OE</sup>	90.4 in (2295 mm), over license-plate carrier
Motorcycle height	53.4 in (1356 mm), over windshield, at DIN unladen weight
– with lowered <sup>OE</sup>	52.4 in (1330 mm), over windshield, at DIN unladen weight
Motorcycle width	36.3 in (922 mm), with mirrors 39.3 in (999 mm), with cases 34.5 in (877 mm), without mounted parts
Front-seat height	33.9 in (860 mm), without rider at DIN unloaded vehicle weight
– with seat, low <sup>OE</sup>	32.9 in (835 mm), without rider at DIN unloaded vehicle weight
– with comfort seat <sup>OE</sup>	34.4 in (875 mm), without rider at DIN unloaded vehicle weight
– with lowered <sup>OE</sup> – with seat, low <sup>OE</sup>	32.1 in (815 mm), without rider at DIN unloaded vehicle weight

Rider's inside-leg arc, heel to heel	75.2 in (1910 mm), without rider, at DIN unladen weight
– with seat, low <sup>OE</sup>	73.6 in (1870 mm), without rider, at DIN unladen weight
– with comfort seat <sup>OE</sup>	76.8 in (1950 mm), without rider, at DIN unladen weight
– with lowered <sup>OE</sup>	72 in (1830 mm), without rider, at DIN unladen weight

## Weights

Unloaded vehicle weight	505 lbs (229 kg), DIN unloaded vehicle weight, ready for road, 90 % full tank of gas, without OE
Gross vehicle weight	981 lbs (445 kg)
Maximum payload	476 lbs (216 kg)

## Performance data

Maximum speed	>124 mph (>200 km/h)
– with case <sup>OA</sup>	99 mph (160 km/h)
– with topcase <sup>OA</sup>	99 mph (160 km/h)

## Service

Reporting safety defects .....	254
BMW Motorrad Service .....	255
BMW Motorrad Service History ....	255
BMW Motorrad Mobility Services .....	256
Maintenance procedures .....	256
Maintenance schedule .....	259
Maintenance confirmations .....	260
Service confirmations .....	274

## Reporting safety defects

If you think that your motorcycle has a fault which may cause an accident, injury or death, you must inform the NHTSA (National Highway Traffic Safety Administration) immediately and BMW of North America, LLC.

If the NHTSA receives other similar complaints, it may open an investigation. If it finds that a safety defect exists in a group of vehicles, the NHTSA may order the manufacturer to perform a recall and remedy campaign. However, the NHTSA cannot become involved in individual problems between you, your authorized BMW Motorrad retailer, or BMW of North America, LLC.

You can contact the NHTSA by calling the Vehicle Safety Hotline on 1-888-327-4236 (Teletypewriter TTY for the hearing impaired: 1-800-424-9153) for free, by visiting the website at <http://www.safercar.gov> or by writing to Administrator, NHTSA, 400 Seventh Street, SW., Washington, DC 20590. Further information on vehicle safety is available at <http://www.safercar.gov>.

## BMW Motorrad Service

With its worldwide retailer network, BMW Motorrad can attend to you and your motorcycle in over 100 countries around the globe. Authorized BMW Motorrad retailers have the technical information and expertise needed to conduct reliable service and repairs covering every aspect of your BMW.

You will find the nearest authorized BMW Motorrad retailer to you at our website:

**[bmw-motorrad.com](http://bmw-motorrad.com)**



### WARNING

#### **Improperly performed maintenance and repair work**

Accident hazard caused by subsequent damage

- BMW Motorrad recommends having corresponding work on the motorcycle carried out

by a specialized workshop, preferably by an authorized BMW Motorrad retailer. ◀

To ensure that your BMW consistently remains in optimal condition BMW Motorrad urges you to observe the recommended service intervals.

Have all maintenance and repair work confirmed in the "Service" chapter in this manual. Documentation confirming regular maintenance is essential for generous treatment of claims submitted after the warranty period has expired (goodwill).

You can obtain information on the contents of the BMW Services from your BMW Motorrad retailer.

## BMW Motorrad Service History

### Entries

Maintenance work that has been performed is recorded in the diagnostics and information system. Like a Service Booklet, these entries provide proof of regular maintenance.

If an entry is made in the vehicle's electronic Service Manual, service-related data is stored on the central IT systems of BMW AG in Munich, Germany.

When there is a change in vehicle owner, the data entered in the electronic Service History can also be viewed by the new vehicle owner. A BMW Motorrad retailer or specialist workshop can view the data entered in the electronic Service Manual.

## Objection

At the BMW Motorrad retailer or specialist workshop, the vehicle owner can object to the entry of data in the electronic Service Manual with the related storage of data in the vehicle and the transfer of data to the vehicle manufacturer during his time as the vehicle owner. In this case, no entry is made in the vehicle's electronic Service Manual.

## BMW Motorrad Mobility Services

The BMW Motorrad Mobility Services furnish you and your new BMW motorcycle with extra security by offering a wide array of assistance services in the event of a breakdown (BMW Roadside Assistance, breakdown assistance, vehicle recovery and retrieval, etc.).

Contact your authorized BMW Motorrad partner for

additional information on available mobility services.

## Maintenance procedures

### BMW pre-delivery check

The BMW pre-delivery check is carried out by your authorized BMW Motorrad retailer before it turns the motorcycle over to you.

### BMW Running-in Check

The BMW running-in check must be carried out between 300 mi. (500 km) and 750 mi. (1200 km).

### BMW Service

BMW Service is carried out once a year. The scope of the services performed may be dependent on the motorcycle owner and the mileage driven. Your BMW Motorrad retailer confirms that the service has been per-

formed and enters the date for the next service.

For riders who drive long distances annually, it may be necessary to come in for service before the entered date. In this case a corresponding maximum odometer reading will also be entered in the confirmation of service. If this odometer reading is reached before the next service date, service must be performed sooner.

The service interval indicator in the display reminds you of the next service date approx. one month or 620 miles (1000 km) before the entered values.

More information on the topic of service is available at:

**[bmw-motorrad.com/service](http://bmw-motorrad.com/service)**

The required scope of maintenance work for your motorcycle can be found in the following maintenance schedule:



## Maintenance schedule

- 1** BMW running-in check
- 2** BMW standard scope of service
- 3** Engine oil change with filter
- 4** Check valve clearance
- 5** Replace all spark plugs
- 6** Replace air filter insert
- 7** Check or replace air filter insert
- 8** Oil change in the telescopic forks
- 9** Change brake fluid in entire system
  - a** annually or every 6000 miles (10000 km) (whichever comes first)
  - b** when used off-road, annually or every 6000 miles (10000 km) (whichever comes first)
  - c** at first after one year, then every two years

## Maintenance confirmations

### BMW Service standard scope

The repair procedures belonging to the BMW Service standard package are listed below. The actual maintenance work applicable for your vehicle may differ.

- Performing the vehicle test using the BMW Motorrad diagnosis system
- Checking coolant level
- Checking/adjusting clutch play
- Checking the front brake pads and brake discs for wear
- Checking the rear brake pads and brake disc for wear
- Checking the front and rear brake fluid level
- Visual inspection of the brake lines, brake hoses, and connections
- Check the tension of the spokes and tighten as needed
- Checking the tire pressure and tread depth
- Checking and lubricating the chain drive
- Checking side stand for ease of movement
- Checking the center stand for ease of movement
- Checking steering-head bearing
- Checking the lighting and signal system
- Functional check for engine starting suppression
- Final inspection and road safety check
- Set the service date and remaining distance using the BMW Motorrad diagnostic system
- Checking charging state of battery
- Confirm the BMW service in the vehicle literature

## **BMW pre-delivery check**

performed

on \_\_\_\_\_

\_\_\_\_\_  
Stamp, signature

## **BMW Running-in Check**

performed

on \_\_\_\_\_

at km \_\_\_\_\_

Next service

latest

on \_\_\_\_\_

or, if reached earlier

at km \_\_\_\_\_

\_\_\_\_\_  
Stamp, signature

**BMW Service**

performed

on \_\_\_\_\_

at km \_\_\_\_\_

Next service

latest

on \_\_\_\_\_

or, if reached earlier

at km \_\_\_\_\_

Work performed

BMW Service

Engine oil change with filter

Checking valve clearance

Replacing all spark plugs

Replacing air cleaner element

Checking or replacing air cleaner element (maintenance)

Oil change - telescopic fork

Changing brake fluid in entire system

Yes

No

Information

-----

-----

-----

-----

-----

-----

-----

-----

\_\_\_\_\_

Stamp, signature

**BMW Service**

performed

on \_\_\_\_\_

at km \_\_\_\_\_

Next service

latest

on \_\_\_\_\_

or, if reached earlier

at km \_\_\_\_\_

Work performed

BMW Service

Engine oil change with filter

Checking valve clearance

Replacing all spark plugs

Replacing air cleaner element

Checking or replacing air cleaner element (maintenance)

Oil change - telescopic fork

Changing brake fluid in entire system

Yes No

Information

-----  
-----  
-----  
-----  
-----  
-----  
-----  
-----

\_\_\_\_\_  
Stamp, signature

**BMW Service**

performed

on \_\_\_\_\_

at km \_\_\_\_\_

Next service

latest

on \_\_\_\_\_

or, if reached earlier

at km \_\_\_\_\_

Work performed

BMW Service

Engine oil change with filter

Checking valve clearance

Replacing all spark plugs

Replacing air cleaner element

Checking or replacing air cleaner element (maintenance)

Oil change - telescopic fork

Changing brake fluid in entire system

Yes

No

Information

-----

-----

-----

-----

-----

-----

-----

-----

\_\_\_\_\_  
Stamp, signature

**BMW Service**

performed

on \_\_\_\_\_

at km \_\_\_\_\_

Next service

latest

on \_\_\_\_\_

or, if reached earlier

at km \_\_\_\_\_

Work performed

BMW Service

Engine oil change with filter

Checking valve clearance

Replacing all spark plugs

Replacing air cleaner element

Checking or replacing air cleaner element (maintenance)

Oil change - telescopic fork

Changing brake fluid in entire system

Yes No

Information

-----  
-----  
-----  
-----  
-----  
-----  
-----  
-----

\_\_\_\_\_  
Stamp, signature

**BMW Service**

performed

on \_\_\_\_\_

at km \_\_\_\_\_

Next service

latest

on \_\_\_\_\_

or, if reached earlier

at km \_\_\_\_\_

Work performed

BMW Service

Engine oil change with filter

Checking valve clearance

Replacing all spark plugs

Replacing air cleaner element

Checking or replacing air cleaner element (maintenance)

Oil change - telescopic fork

Changing brake fluid in entire system

Yes

No

Information

-----

-----

-----

-----

-----

-----

-----

-----

\_\_\_\_\_

Stamp, signature

**BMW Service**

performed

on \_\_\_\_\_

at km \_\_\_\_\_

Next service

latest

on \_\_\_\_\_

or, if reached earlier

at km \_\_\_\_\_

Work performed

BMW Service

Engine oil change with filter

Checking valve clearance

Replacing all spark plugs

Replacing air cleaner element

Checking or replacing air cleaner element (maintenance)

Oil change - telescopic fork

Changing brake fluid in entire system

Yes      No

Information

-----  
-----  
-----  
-----  
-----  
-----  
-----  
-----

\_\_\_\_\_  
Stamp, signature

**BMW Service**

performed

on \_\_\_\_\_

at km \_\_\_\_\_

Next service

latest

on \_\_\_\_\_

or, if reached earlier

at km \_\_\_\_\_

Work performed

BMW Service

Engine oil change with filter

Checking valve clearance

Replacing all spark plugs

Replacing air cleaner element

Checking or replacing air cleaner element (maintenance)

Oil change - telescopic fork

Changing brake fluid in entire system

Yes

No

Information

-----

-----

-----

-----

-----

-----

-----

-----

\_\_\_\_\_

Stamp, signature

**BMW Service**

performed

on \_\_\_\_\_

at km \_\_\_\_\_

Next service

latest

on \_\_\_\_\_

or, if reached earlier

at km \_\_\_\_\_

Work performed

BMW Service

Engine oil change with filter

Checking valve clearance

Replacing all spark plugs

Replacing air cleaner element

Checking or replacing air cleaner element (maintenance)

Oil change - telescopic fork

Changing brake fluid in entire system

Yes No

Information

-----  
-----  
-----  
-----  
-----  
-----  
-----  
-----

\_\_\_\_\_  
Stamp, signature

**BMW Service**

performed

on \_\_\_\_\_

at km \_\_\_\_\_

Next service

latest

on \_\_\_\_\_

or, if reached earlier

at km \_\_\_\_\_

Work performed

BMW Service

Yes

No

Engine oil change with filter

Checking valve clearance

Replacing all spark plugs

Replacing air cleaner element

Checking or replacing air cleaner element (maintenance)

Oil change - telescopic fork

Changing brake fluid in entire system

Information

-----

-----

-----

-----

-----

-----

-----

-----

\_\_\_\_\_

Stamp, signature

**BMW Service**

performed

on \_\_\_\_\_

at km \_\_\_\_\_

Next service

latest

on \_\_\_\_\_

or, if reached earlier

at km \_\_\_\_\_

Work performed

BMW Service

Engine oil change with filter

Checking valve clearance

Replacing all spark plugs

Replacing air cleaner element

Checking or replacing air cleaner element (maintenance)

Oil change - telescopic fork

Changing brake fluid in entire system

Yes      No

Information

-----  
-----  
-----  
-----  
-----  
-----  
-----  
-----

\_\_\_\_\_  
Stamp, signature

**BMW Service**

performed

on \_\_\_\_\_

at km \_\_\_\_\_

Next service

latest

on \_\_\_\_\_

or, if reached earlier

at km \_\_\_\_\_

Work performed

BMW Service

Engine oil change with filter

Checking valve clearance

Replacing all spark plugs

Replacing air cleaner element

Checking or replacing air cleaner element (maintenance)

Oil change - telescopic fork

Changing brake fluid in entire system

Yes

No

Information

-----

-----

-----

-----

-----

-----

-----

-----

\_\_\_\_\_

Stamp, signature

**BMW Service**

performed

on \_\_\_\_\_

at km \_\_\_\_\_

Next service

latest

on \_\_\_\_\_

or, if reached earlier

at km \_\_\_\_\_

Work performed

BMW Service

Engine oil change with filter

Checking valve clearance

Replacing all spark plugs

Replacing air cleaner element

Checking or replacing air cleaner element (maintenance)

Oil change - telescopic fork

Changing brake fluid in entire system

Yes      No

Information

-----  
-----  
-----  
-----  
-----  
-----  
-----  
-----  
-----

\_\_\_\_\_  
Stamp, signature



Work performed	at km	Date



## Appendix

Certificate for electronic immobilizer .....	278
Certificate for Keyless Ride .....	280
Certificate for tire pressure control .....	282
Certificate for TFT instrument cluster .....	283

## FCC Approval

### Ring aerial in the ignition switch



To verify the authorization of the ignition key, the electronic immobilizer exchanges information with the ignition key via the ring aerial.

This device complies with Part 15 of the FCC rules. Operation is subject to the following two conditions:

- (1) This device may not cause harmful interference, and
- (2) this device must accept any interference received, including interference that may cause undesired operation.



Any changes or modifications not expressly approved by the party responsible for compliance could void the user's authority to operate the equipment. ◀

## Approbation de la FCC

### Antenne annulaire présente dans le commutateur d'allumage



Pour vérifier l'autorisation de la clé de contact, le système d'immobilisation électronique échange des

informations avec la clé de contact via l'antenne annulaire.

Le présent dispositif est conforme à la partie 15 des règles de la FCC. Son utilisation est soumise aux deux conditions suivantes :

- (1) Le dispositif ne doit pas produire d'interférences nuisibles, et
- (2) le dispositif doit pouvoir accepter toutes les interférences extérieures, y compris celles qui pourraient provoquer une activation inopportune.



Toute modification qui n'aurait pas été approuvée expressément par l'organisme responsable de l'homologation peut annuler l'autorisation accordée à l'utilisateur pour utiliser le dispositif. ◀

## Certifications

---

### BMW Keyless Ride ID Device



#### USA, Canada

Product name: BMW Keyless Ride ID Device  
FCC ID: YGOHUF5750  
IC: 4008C-HUF5750

#### Canada:

Operation is subject to the following two conditions:

- (1) This device may not cause harmful interference, and
- (2) this device must accept any interference received, including interference that may cause undesired operation.

#### USA:

This device complies with Part 15 of the FCC rules. Operation is subject to the following two conditions:

- (1) This device may not cause harmful interference, and
- (2) this device must accept any interference received, including interference that may cause undesired operation.



Any changes or modifications not expressly approved by the party responsible for compliance could void the user's authority to operate the equipment.

# Declaration Of Conformity

---

We declare under our responsibility that the product

## **BMW Keyless Ride ID Device (Model: HUF5750)**

complies with the appropriate essential requirements of the article 3 of the R&TIE and the other relevant provisions, when used for its intended purpose. Applied Standards:

1. Health and safety requirements contained in article 3 (1) a)
  - EN 60950-1:2006+A11:2009+A1:2010+A12:2011; Information technology equipment- Safety
2. Protection requirements with respect to electromagnetic compatibility article 3 (1) b)
  - EN 301 489-1 (V1 .9.2, 09/2011 ), Electromagnetic compatibility and radio spectrum matters (ERM); Electromagnetic compatibility (EMC) standard for radio equipment and services; Part 1: Common technical requirements
  - EN 301 489-3 (V1.4.1, 08/2002) Electromagnetic compatibility and radio spectrum matters (ERM); Electromagnetic compatibility (EMC) standard for radio equipment and services; Part 3: Specific conditions for short range devices (SRD) operating on frequencies between 9 kHz and 40 GHz
3. Means of the efficient use of the radio frequency spectrum article 3 (2)
  - EN 300 220-1 & -2 (V2.4.1, 05/2012), electromagnetic compatibility and radio spectrum matters (ERM); Short range devices (SRD); Radio equipment to be used in the 25 MHz to 1000 MHz frequency range with power levels ranging up to 500 mW;  
Part 1: Technical characteristics and test methods.  
Part 2: Harmonized EN covering essential requirements under article 3.2 of the R&TIE directive

The product is labeled with the CE marking: **CE**

Velbert, October 15<sup>th</sup>, 2013

---

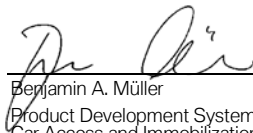

---

Benjamin A. Müller  
Product Development Systems  
Car Access and Immobilization – Electronics  
Huf Hüsbeck & Fürst GmbH & Co. KG  
Steeger Straße 17, D-42551 Velbert

## Certification Tire Pressure Control (TPC)

---

FCC ID: MRXBC54MA4  
IC: 2546A-BC54MA4

FCC ID: MRXBC5A4  
IC: 2546A-BC5A4

This device complies with Part 15 of the FCC Rules and with Industry Canada license-exempt RSS standard(s).

Operation is subject to the following two conditions:

- (1) This device may not cause harmful interference, and
- (2) This device must accept any interference received, including interference that may cause undesired operation.

Le présent appareil est conforme aux CNR d'Industrie Canada applicables aux appareils radio exempts de licence. L'exploitation est autorisée aux deux conditions suivantes:

- (1) l'appareil ne doit pas produire de brouillage, et
- (2) l'utilisateur de l'appareil doit accepter tout brouillage radioélectrique subi, même si le brouillage est susceptible d'en compromettre le fonctionnement.

**WARNING:** Changes or modifications not expressly approved by the party responsible for compliance could void the user's authority to operate the equipment. The term "IC:" before the radio certification number only signifies that Industry Canada technical specifications were met.

# Declaration of Conformity

## Radio equipment TFT instrument cluster

For all Countries without EU

### Technical information

BT operating frq. Range: 2402 – 2480 MHz

BT version: 4.2 (no BTLE)

BT output power: < 4 dBm

WLAN operating frq. Range: 2412 – 2462 MHz

WLAN standards: IEEE 802.11 b/g/n

WLAN output power: < 20 dBm

### Manufacturer and Address

Manufacturer:

Robert Bosch Car Multimedia GmbH

Adress: Robert Bosch Str. 200,

31139 Hildesheim, GERMANY

### Turkey

Robert Bosch Car Multimedia GmbH, ICC6.5in tipi telsiz sisteminin 2014/53/EU nolu yönetmeliğe uygun olduğunu beyan eder. AB Uygunluk Beyanı'nın tam metni, aşağıdaki internet adresinden görülebilir: <http://cert.bosch-carmultimedia.net>

### Brazil

Este equipamento opera em caráter secundário, isto é, não tem direito a proteção contra interferência prejudicial, mesmo de estações do mesmo tipo, e não pode causar interferência a sistemas operando em caráter primário.

## **Canada**

This device complies with Industry Canada's licence-exempt RSSs and part 15 of the FCC Rules. Operation is subject to the following two conditions:

(1) this device may not cause interference, and  
(2) this device must accept any interference, including interference that may cause undesired operation of the device.

Changes or modifications not expressly approved by the party responsible for compliance could void the user's authority to operate the equipment.

Le présent appareil est conforme aux CNR d'Industrie Canada applicables aux appareils radio exempts de licence. L'exploitation est autorisée aux deux conditions suivantes : (1) l'appareil ne doit pas produire de brouillage, et (2) l'appareil doit accepter tout brouillage radioélectrique subi, même si le brouillage est susceptible d'en compromettre le fonctionnement.

## **Mexico**

La operación de este equipo está sujeta a las siguientes dos condiciones:

(1) es posible que este equipo o dispositivo no cause interferencia perjudicial y  
(2) este equipo o dispositivo debe aceptar cualquier interferencia, incluyendo la que pueda causar su operación no deseada.

## **Taiwan, Republic of**

根據 NCC 低功率電波輻射性電機管理辦法 規定：  
第十二條

經型式認證合格之低功率射頻電機，非經許可，公司、商號或使用者均不得擅自變更頻率、加大功率或變更原設計之特性及功能。

### 第十四條

低功率射頻電機之使用不得影響飛航安全及干擾合法通信；經發現有干擾現象時，應立即停用，並改善至無干擾時方得繼續使用。

前項合法通信，

指依電信法規定作業之無線電通信。

低功率射頻電機須忍受合法通信或工業、科學及醫療用電波輻射性電機設備之干擾。

## Thailand

เครื่องโทรคมนาคมและอุปกรณ์นี้

มีความสอดคล้องตามข้อกำหนดของ กทช.

(This telecommunication equipments is in compliance with NTC requirements)

## United States (USA)

This device complies with Industry Canada's licence-exempt RSSs and part 15 of the FCC Rules. Operation is subject to the following two conditions:

(1) this device may not cause interference, and  
(2) this device must accept any interference, including interference that may cause undesired operation of the device.

Changes or modifications not expressly approved by the party responsible for compliance could void the user's authority to operate the equipment.

Le présent appareil est conforme aux CNR d'Industrie Canada applicables aux appareils radio exempts de licence. L'exploitation est autorisée aux deux conditions suivantes : (1) l'appareil ne doit pas produire de brouillage, et (2) l'appareil doit accepter tout brouillage radioélectrique subi, même si le brouillage est susceptible d'en compromettre le fonctionnement.

## Korea

적합성평가에 관한 고시

R-CMM-RBR-ICC651N

상호 : Robert Bosch Car Multimedia

GmbH 모델명 : ICC6.5in

기자재명칭 : 특정소출력 무선기기

(무선데이터통신시스템용 무선기기)

제조사 및 제조국가 : Robert Bosch Car  
Multimedia GmbH / 포르투갈

제조년월 : 제조년월로 표기

이 기기는 업무용 환경에서 사용할 목적으로 적합성평가를 받은 기기로서 가정용 환경에서 사용하는 경우 전파간섭의 우려가 있습니다.

-Coding plug  
Installing, 98

Position on motorcycle, 18

## A

Abbreviations and symbols, 6

### ABS

Displays, 39, 67

Operating, 89

Operating element, 19

Self-diagnosis, 149

Technology in detail, 164

### Accessories

General notes, 214

### Alarm

triggering, 134

### Alarm function

Deactivating, 135

### Ambient temperature

Outside temperature

warning, 32, 58

### Anti-theft alarm system, 131

Indicator light, 22

Warning indicator, 36, 61

## ASC

Displays, 40

Indicator and warning light, 68

Operating, 91

Operating element, 19

Self-diagnosis, 149

Technology in detail, 166

### Average values

Resetting, 84

## B

### Battery

Charge disconnected  
battery, 206

Charging connected  
battery, 205

Indicator light for vehicle  
voltage, 33, 59

Install, 207

Maintenance instructions, 205

Remove, 206

Technical data, 249

### Bluetooth, 120

Pairing, 120

## Brake fluid

Checking the fluid level at  
rear, 183

Checking the front fluid  
level, 182

Front reservoir, 17

Rear reservoir, 17

## Brake pads

Breaking in, 151

Check rear, 181

Checking the front, 181

## Brakes

ABS Pro in detail, 166

ABS Pro dependent on riding  
mode, 155

Adjusting brake lever, 140

Checking function, 180

Safety information, 154

Technical Data, 245

## Break-in, 151

## C

### Care

Chrome, 231

Paint preservation, 232

### Case, 215

- Chain
  - Adjusting chain sag, 211
  - Checking sag, 210
  - Checking wear, 211
  - Lubricating, 210
- Chassis
  - Technical Data, 244
- Check Control
  - Dialog, 49
  - Display, 49
- Checklist, 147
- Clock
  - Adjusting, 85, 86, 119
  - Control, 21
- Clutch
  - Adjust play, 185
  - Adjusting clutch lever, 139
  - Checking operation, 184
  - Checking play, 185
  - Technical Data, 243
- Coolant
  - Check fill level, 186
  - Fluid level indicator, 17
  - Indicator light for excess temperature, 34, 62
  - Topping up, 186
- Cruise-control system
  - Operating, 102
- D**
- Damping
  - Adjustment element, 15
- Date
  - Adjusting, 86
- Deactivating
  - Alarm function, 135
  - motion sensor, 133
- D-ESA
  - Operating, 93
  - Operating element, 19
- Diagnostic socket
  - fasten, 210
  - Loosen, 209
  - Position on motorcycle, 18
- Dimensions
  - Technical Data, 250
- Distance recorder
  - Control, 21
  - Resetting the trip odometer, 84
- DTC
  - Displays, 40
  - Indicator and warning light , 68
  - Operating, 91
  - Self-diagnosis, 150
  - Technology in detail, 166
- E**
- Electrical system
  - Technical Data, 248
- Emergency-off switch
  - Control, 20
  - Operating, 79
- Engine
  - Indicator light for engine control, 63
  - Starting, 147
  - Technical Data, 242
  - Warning light for electronic engine management, 34, 62

- Engine oil
  - Checking fill level, 178
  - Filling location, 15
  - Oil dipstick, 15
  - Technical Data, 241
  - Topping up, 180
- Engine speed warning
  - Warning light, 21
- Equipment, 7
- F**
- Factory settings, 136
- Fairing
  - Refitting fuel tank cover, 203
  - Remove the tank cover, 203
- Frame
  - Technical Data, 244
- Front wheel stand
  - Mounting, 177
- Fuel
  - Fuel grade, 156
  - Fuel reserve, 41
  - Refueling, 157
  - refueling with Keyless Ride, 158, 160
  - Technical data, 241
  - Technical Data, 241
- Fuel reserve
  - Range, 118
  - Warning indicator, 41, 70
- Fuses
  - Position on motorcycle, 18
  - Replacing, 208
- G**
- Gearshift assistant
  - Gear not trained, 71
  - Riding, 152
  - Technology in detail, 172
- H**
- Hazard warning flasher
  - Operating, 81
  - Operating element, 19
- Headlight
  - Headlight range, 138
  - Headlight range adjustment, 139
  - Right-hand/left-hand drive, 138
- Headlight courtesy delay
  - feature, 80
- Heated grips
  - Control, 20
  - Operating, 105
- Horn, 19
- I**
- Ignition
  - Switching off, 75
  - Switching on, 74
- Immobilizer
  - Emergency key, 78
  - Warning indicator, 32
- Indicator lights, 22
  - ABS, 39, 67
  - Alarm system, 36
  - Anti-theft alarm system, 61
  - ASC, 68
  - ASC/DTC, 40
  - Bulb faulty, 35, 60
  - Coolant temperature, 34, 62
  - DTC, 68
  - Electronic engine management, 34, 62
  - Engine management system, 63

- EWS active, 32
- Fuel reserve, 41, 70
- Gear not trained, 71
- Layout, 27, 49
- My vehicle, 123
- My Vehicle, 123
- Outside temperature warning, 32, 58
- Overview, 24, 44
- TPM Tire Pressure Monitor, 37, 63
- Vehicle voltage, 33, 59

Instrument cluster

- Adjust units, 88
- Ambient light photosensor, 22
- Overview, 21, 22
- Photosensor, 21
- Set brightness of backlighting, 88

**J**

- Jump-starting, 203

## **K**

- Keyless Ride
  - Battery of the key fob transmitter is empty or the key fob transmitter is lost, 77
  - Indicator light, 33, 59
  - Locking handlebars, 76
  - Switch off ignition, 77
  - Switching on ignition, 76
  - Unlocking fuel filler cap, 158, 160
  - Warning indicator, 33, 58
- Keys, 74, 75

## **L**

- Light sources
  - Replacing auxiliary headlights, 202
  - Replacing bulb for brake and rear light, 200
  - Replacing the LED for lowbeam headlights and high beams, 200
  - Replacing the LED for the parking lights, 200

- Replacing the license-plate bulb, 201
- Technical data, 249
- Turn indicators, 200
- Warning for defective bulb, 35, 60

Lights

- Headlight courtesy delay feature, 80
- Low beams, 80
- Operating element, 19
- Operating headlight flasher, 80
- Operating high-beam headlight, 80
- Operating parking lights, 81
- Parking lights, 80

Lowered suspension

- Limitations, 144

Luggage

- Loading information, 144

**M**

- Maintenance
  - Maintenance schedule, 259
- Maintenance confirmations, 260
- Maintenance intervals, 256
- Media
  - Operating, 128
- Menu
  - Calling up, 114
- Mirrors
  - Adjusting, 138
- Mobility Services, 256
- Motion sensor
  - Deactivating, 133
- Motorcycle
  - Care, 229
  - Cleaning, 229
  - Parking, 156
  - Putting into operation, 233
  - Removal from operation, 232
  - Tying down, 161
- Multifunction display, 21
  - Adjusting the display, 88
  - Exit SETUP, 86
  - Operating, 83
  - Overview, 25

- Selecting display, 83
- SETUP, 85

- Multifunction switch
  - Overall view, left, 19
  - Overall view, right, 20

**N**

- Navigation
  - Operating, 126
- Notice concerning current status, 8

**O**

- Off-road mode
  - Adjusting, 96
  - Technology in detail, 168
- Offroad riding, 153
- Onboard computer, 126
  - On the multifunction display, 83
- Onboard vehicle toolkit
  - Position on motorcycle, 18
- Operating focus
  - change, 115

- Outside temperature
  - Display, 32, 58

- Overview of warning indicators, 28, 51

**Overviews**

- Indicator and warning lights, 24, 44
- Instrument cluster, 21
- Instrument cluster with connectivity, 22
- Left side of motorcycle, 15
- Left-side multifunction switch, 19
- Multifunction display, 25
- Multifunction switch, right, 20
- My vehicle, 123
- My Vehicle, 123
- Right side of vehicle, 17
- SETUP, 85
- TFT display, 45, 47
- Underneath seat, 18

**P**

- Pairing, 120
- Parking light, 81

Performance data  
  Technical data, 252

Phone  
  Operating, 129

Pre-Ride-Check, 148

Pure Ride  
  Overview, 45

## **R**

TPC/RDC  
  Technology in detail, 171  
  Warning lights, 37, 63

Rear-wheel drive  
  Technical Data, 244

Refueling, 157  
  Fuel grade, 156  
  with Keyless Ride, 158, 160

Remote control  
  Replacing the battery, 78

Rider info status line  
  Adjusting, 116

Rider's Manual (US Model)  
  Placement, 107  
  Position on motorcycle, 18

Riding mode, 96  
  Setting the PRO riding  
  mode, 99  
  Setting the PRO riding mode  
  with connectivity, 101

Riding time  
  Resetting, 84

Road sign detection  
  switch on or off, 117

## **S**

Safety information  
  On braking, 154  
  On riding, 144

Screw connections, 239

Seat  
  Installing, 106  
  Locking mechanism, 15

Removing, 106  
Service, 255  
  Reporting safety defects, 254

Service History, 255  
Service display, 42, 71

SETUP  
  Exit, 86  
  Resetting, 89  
  Select, 85  
Shifting gears  
  Upshift recommendation, 42,  
  118

Socket  
  Information on use, 214  
  Position on vehicle, 15

Spark plugs  
  Technical data, 249

Speedometer, 21, 22

Spring preload  
  Adjusting, 140  
  Adjusting element, 17

Start, 147  
  Control, 20

Steering lock  
  Locking, 74

Switching off, 156

## **T**

Tachometer, 21, 22  
  Tachometer, 117

- Technical data
  - Battery, 249
  - Brakes, 245
  - Chassis, 244
  - Clutch, 243
  - Dimensions, 250
  - Electrical system, 248
  - Engine, 242
  - Engine oil, 241
  - Frame, 244
  - Fuel, 241
  - General notes, 7
  - Light sources, 249
  - Performance data, 252
  - Rear-wheel drive, 244
  - Spark plugs, 249
  - Standards, 7
  - Transmission, 243
  - Weights, 251
  - Wheels and tires, 246
- TFT display, 22
  - Operating, 114, 115, 116
  - Operating element, 19
  - Overview, 45, 47
  - Selecting display, 111
- Tire Pressure Control TPC/RDC
  - Display, 36
- Tires
  - Breaking in, 152
  - Checking tire pressure, 187
  - Checking tire tread depth, 188
  - Checking tread depth, 188
  - Recommendation, 189
  - Technical Data, 246
  - tire pressures, 248
  - Top speed, 145
- Topcase
  - Operating, 218
- Torques, 239
- Traction Control
  - ASC, 166
  - DTC, 166
- Transmission
  - Technical Data, 243
- Trip recorder
  - Resetting, 84
- Troubleshooting chart, 236
- Turn signals
  - Operating, 82
  - Operating element, 19
- Type plate
  - Position on motorcycle, 17
- V**
- Values
  - Display, 49
- Vehicle identification number
  - Position on motorcycle, 17
- Vehicle voltage
  - Warning indicator, 33, 59
- W**
- Warning lights, 22
  - Overview, 24, 44
- Weights
  - Load capacity table, 18
  - Technical Data, 251
- Wheels
  - Checking rims, 188
  - Checking spokes, 188

Checking wheel rims, 188  
Installing rear wheel, 197  
Installing the front wheel, 192  
Removing front wheel, 189  
Removing the rear wheel, 195  
Size change, 189  
Technical Data, 246



The descriptions and illustrations in this manual may vary from your own motorcycle's actual equipment, depending upon its equipment level and accessories as well as your specific national version. No claims stemming from these differences can be recognized.

Dimensions, weights, fuel consumption and performance data are quoted to the customary tolerances.

The right to modify designs, equipment and accessories is reserved.

Errors and omissions excepted.

© 2019 Bayerische Motoren Werke Aktiengesellschaft  
80788 Munich, Germany  
Reprints and duplication of this work, in whole or part, are prohibited without the express written approval of BMW Motorrad, Aftersales.

Original Rider's Manual, printed in Germany.

## **WARNING**

### **Harmful substances**

Operating, servicing and maintaining a passenger vehicle or off-road vehicle can expose you to chemicals including engine exhaust, carbon monoxide, phthalates and lead, which are known to the State of California to be carcinogenic or detrimental to childbirth or reproduction.

- To minimize exposure, avoid breathing exhaust, do not idle the engine except as necessary, service your vehicle in a well-ventilated area and wear gloves or wash your hands frequently when servicing your vehicle.
- For more information visit: [www.P65Warnings.ca.gov/passenger-vehicle](http://www.P65Warnings.ca.gov/passenger-vehicle) ◀

